



instal.

# ILUMINACIÓN

SISTEMAS CON ILUMINACIÓN ECOLÓGICA

KADÍ CREMALLERA ELEKTRIC  
EXPLOSIONADO GENERAL  
MONTAJE EN SERIE  
MONTAJE ELÉCTRICO  
MONTAJE PLAFONES  
MONTAJE CREM. ELEKTR.  
(ESQUEMA) ACCES.PRIMO  
TABLA DE PESOS  
COMPORTAMIENTO PESOS  
PLUG & PLAY  
DESPIECE ACCESORIOS  
COMPONENTES POR PIEZA  
COMP. FACIL CONEXIÓN  
ACCES. CON COMPON.

KADÍ PHARMA ELEKTRIC  
EXPLOSIONADO GENERAL  
MONTAJE EN SERIE  
MONTAJE CON MAGNETIC  
MONTAJE CON EASY  
MONTAJE PLAFONES  
INF. TOPE, GRAPAS, CABLE  
INF. CARRIL ELÉCTRICO  
INF. CONECTOR  
INF. CARRIL-CABLE  
(ESQUEMA) ACCES.PRIMO  
TABLA DE PESOS  
COMPORTAMIENTO PESOS  
PLUG & PLAY  
COMPONENTES POR PIEZA  
COMP. FACIL CONEXIÓN  
PIES Y ANCLAJES  
TIRANTES  
JUNTAS Y TAPAS  
ACCES. CON COMPON.

KADÍ PRIMO ELEKTRIC  
EXPLOSIONADO GENERAL  
MONTAJE EN SERIE  
MONTAJE CON MAGNETIC  
MONTAJE CON EASY  
INF. TOPE, GRAPAS, CABLE  
INF. CARRIL ELÉCTRICO  
INF. CONECTOR  
INF. CARRIL-CABLE  
(ESQUEMA) ACCES.PRIMO  
TABLA DE PESOS  
COMPORTAMIENTO PESOS  
PLUG & PLAY  
COMPONENTES POR PIEZA  
COMP. FACIL CONEXIÓN

NUDOS PRESIÓN  
NUDOS BRIDA  
TAPONES  
TUBO  
OTROS ACCESORIOS  
ACCES. CON COMPON.

SITEMA CUT-LINE

PERFILES ILUMINACIÓN Y LEDS

EASY LIGHT - MAGNETIC LED  
SITEMA  
COMPONENTES

EASY LIGHT - EASY  
SITEMA  
COMPONENTES

SISTEMA VARIO  
COMPONENTES



KADÍ CREMALLERA ALU - ELEKTRIC





INSTAL  
ILUMINACIÓN

ALU  
SYSTEM

KADÍ ELEKTRIC  
CREMALLERAS ALU i.191

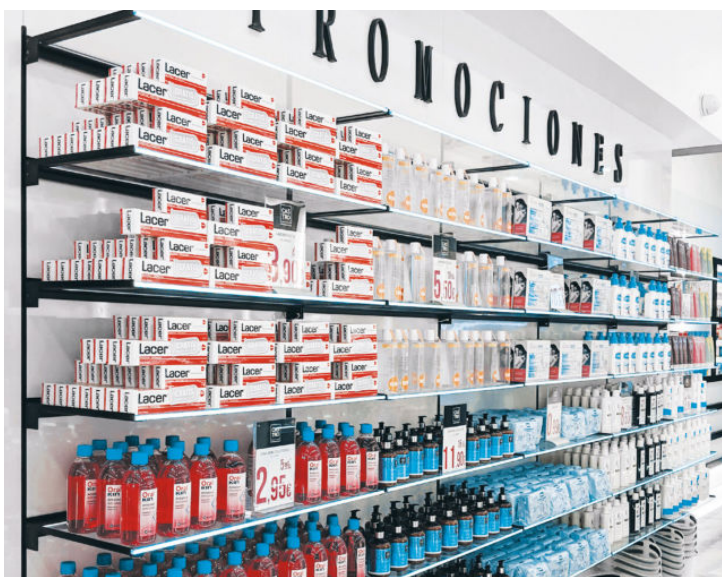

ESCANEA ESTE QR  
PARA VER TODAS  
LAS IMÁGENES DE LA  
CREMALLERA ALU



## KADÍ CREMALLERA ELEKTRIC

Ejemplos orientativos  
de distintas posibilidades,  
distribuciones y  
aplicaciones



## EXPLOSIONADO GENERAL

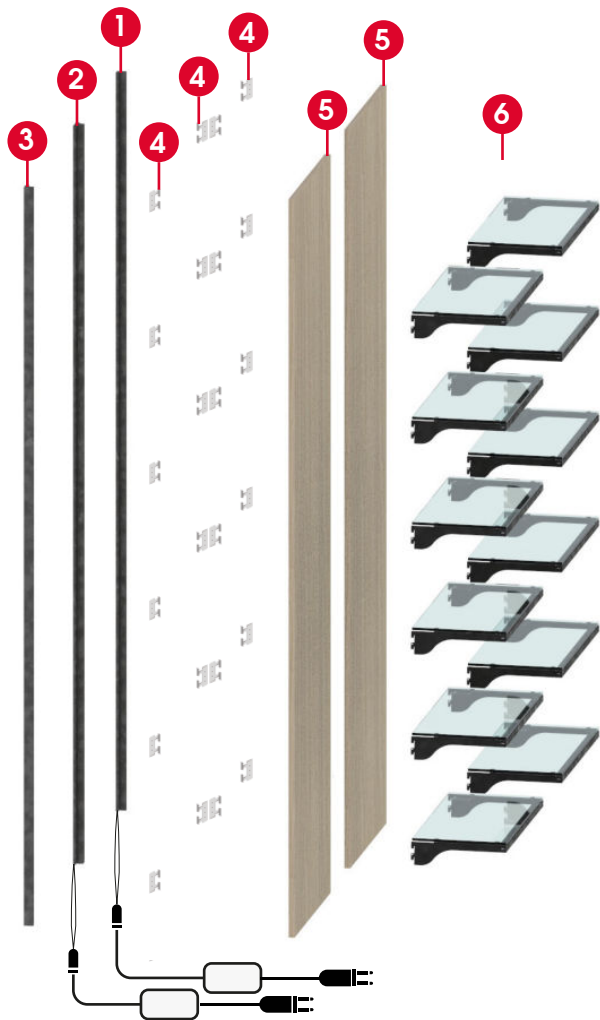

## MONTAJE EN SERIE

Colocar las cremalleras **ELECTRIFICADAS**  
EN EL LADO DERECHO de cada panel

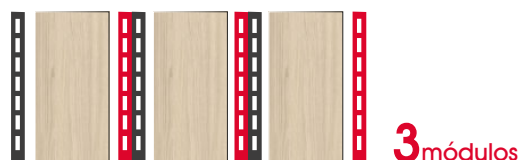

REF: 4872 (CREMALLERA  
1 CANAL)  
+ 4871 (CARRIL  
ELEKTRIC)

Cremalleras  
electrificadas  
exteriores  
- 1 canal

REF: 4870 (CREMALLERA  
2 CANALES)  
+ 4871 (CARRIL  
ELEKTRIC)

Cremalleras  
electrificadas  
interiores  
- 2 canales

REF: 4872 (CREMALLERA  
1 CANAL)

Cremalleras  
sin carril  
eléctrico  
exteriores  
- 1 canal

**1** Cremallera  
electrificada  
- 1 canal  
REF: 4872  
+4871



**2** Cremallera  
electrificada  
- 2 canales  
REF: 4870  
+4871



**3** Cremallera  
sin carril  
eléctrico  
- 1 canal  
REF: 4872



**4** Grapas para  
colgar  
paneles  
2 posibles  
modelos:  
- Clásicas  
- Modelo  
rediseñado  
con aplicación  
frontal



**5** Paneles  
(NO  
INCLUIDOS)



**6** Accesorios  
Personalizable:  
- Estantes  
- Barras  
- Perroquets



MONTAJE ELÉCTRICO

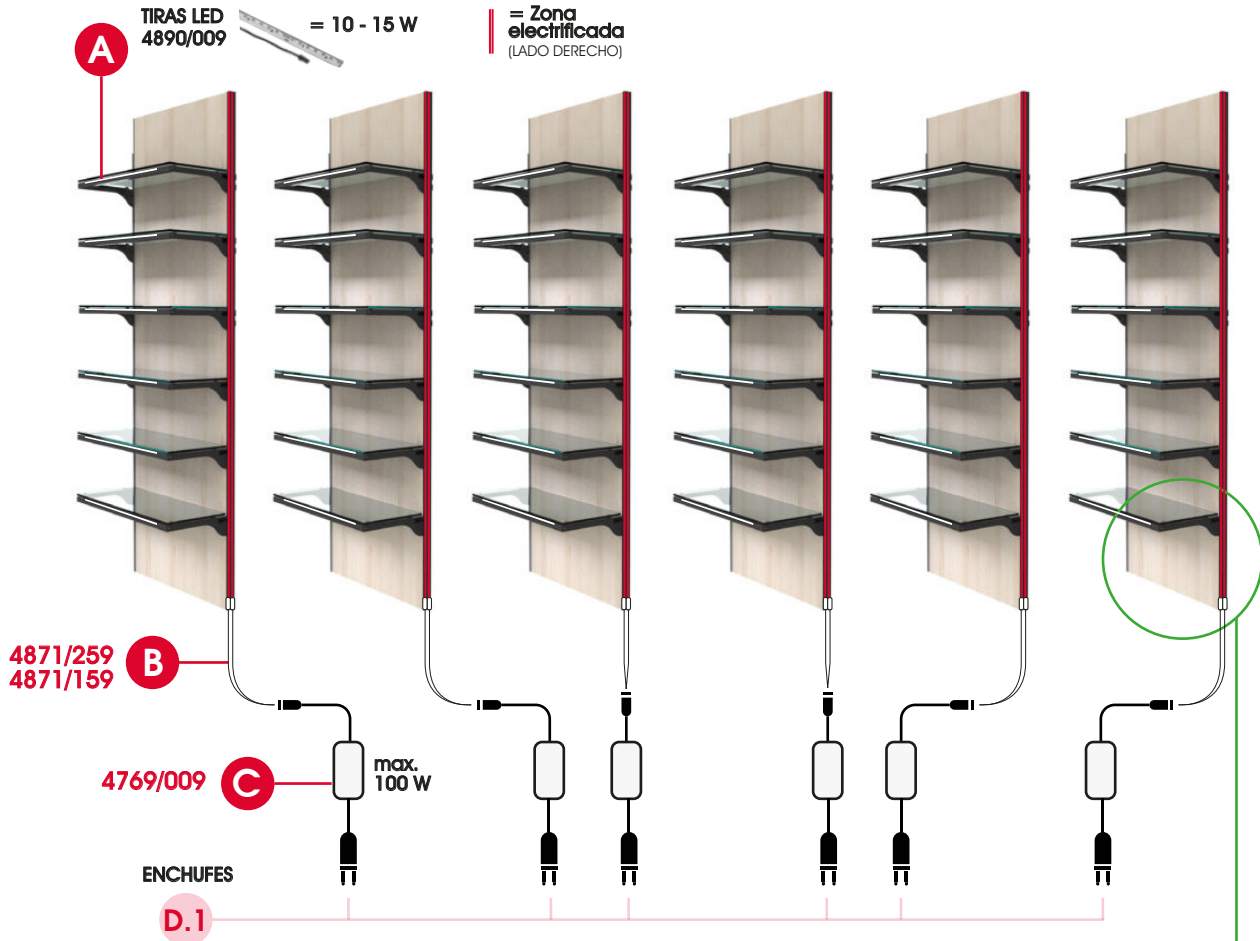

- A** Tiras LED  
(6 ud. por transformador)
- B** Cable con mini conector  
**LONGITUD DEL CABLE - 1M**
- C** Transformador  
(Cada panel debe llevar su transformador)
- D** Regleta de distribución
- D.1** Enchufe

- ES** • El carril electrificado lleva soldado el cable de conexión en la parte inferior. En el caso de prescindir de este conector, prestar atención a la polaridad de los cables para el correcto funcionamiento de la nueva conexión.
- FR** • La voie électrifiée porte le câble de connexion au conducteur en bas. En cas de suppression avec ce connecteur, faites attention à la polarité des câbles pour le bon fonctionnement de la nouvelle connexion.
- EN** • The electrified track carries the connection cable to the driver at the bottom. In the case of dispensing with this connector, pay attention to the polarity of the cables for the correct functioning of the new connection.
- IT** • Il binario elettrificato ha il cavo di connessione al driver saldato nella parte inferiore. Nel caso di prescindere del connettore, controllare la polarità dei cavi per assicurare il corretto funzionamento della nuova connessione.

Cualquier manipulación invalida la garantía del fabricante

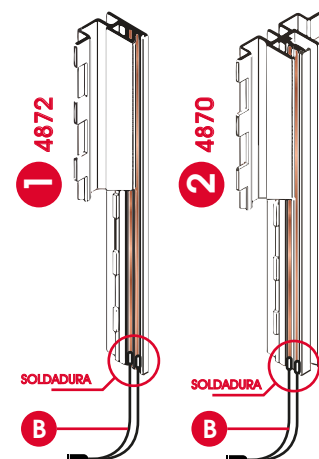



## MONTAJE DE LOS PLAFONES A LAS CREMALLERAS

SISTEMA MEDIANTE ENGANCHES

### ENGANCHES 4616/034

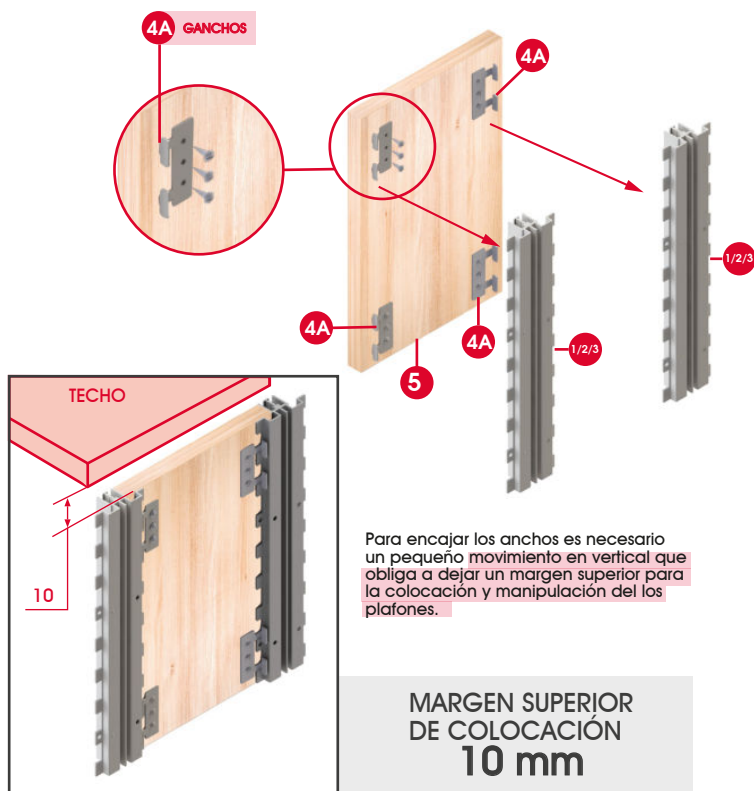

- 1 Cremallera electrificada 1 carril
- 2 Cremallera 2 carriles
- 3 Cremallera sin electrificar 1 carril
- 4 Ganchos / Grapas
- 5 Panel

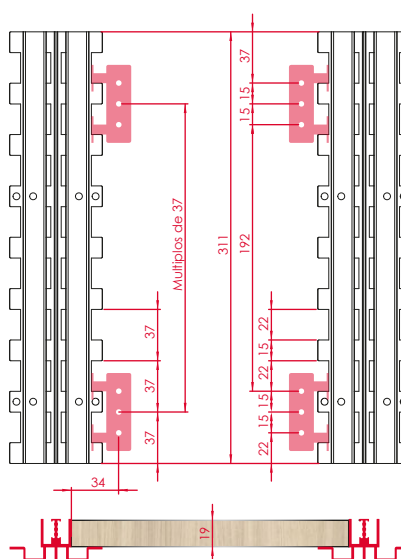

SISTEMA MEDIANTE CLIPAJES

### CLIPAJES 4607/028

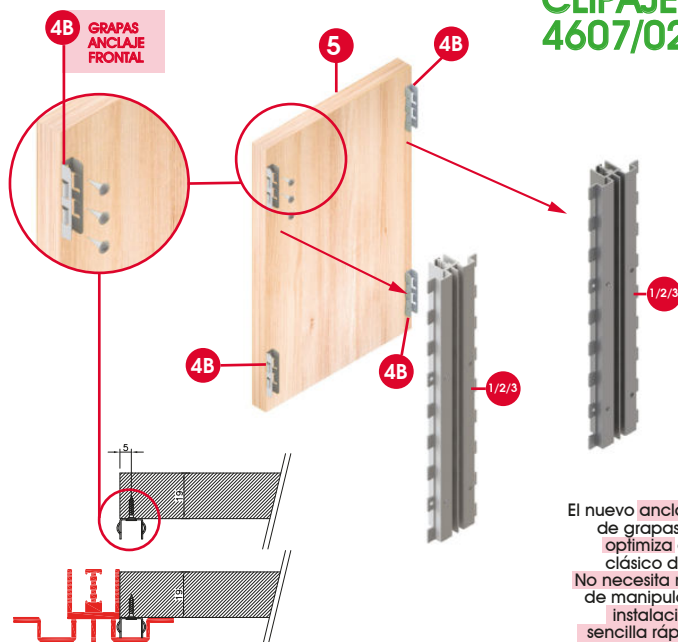

El nuevo anclaje frontal de grapas mejora y optimiza el sistema clásico de grapas. No necesita márgenes de manipulación y la instalación resulta sencilla rápida y con acabados más limpios.





## MONTAJE CREMALLERAS ELECTRIFICADAS

1

### CREMALLERA ELECTRIFICADA 1 CANAL

REF.  
4872

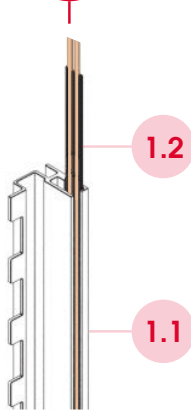

1.1 Cremallera

1.2 Carril eléctrico

2 POSIBLES MEDIDAS (30 - 45 FONDO)

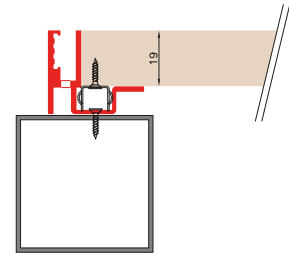
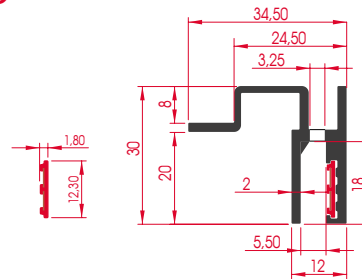
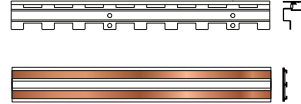

2

### CREMALLERA ELECTRIFICADA 2 CANALES

REF.  
4870

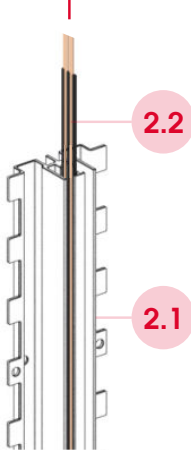

2.1 Cremallera

2.2 Carril eléctrico

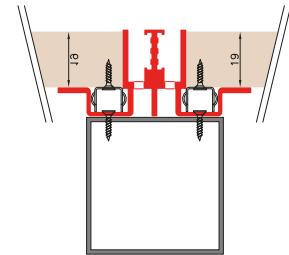
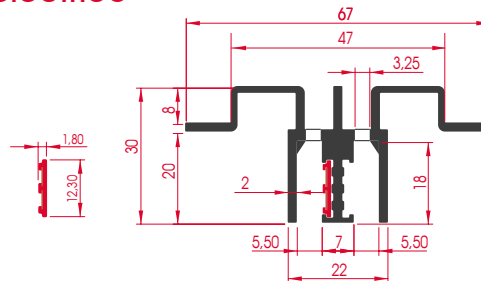
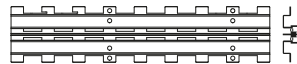

3

### NOVA CREMALLERA ELECTRIFICADA 1 CANAL

REF.  
4874

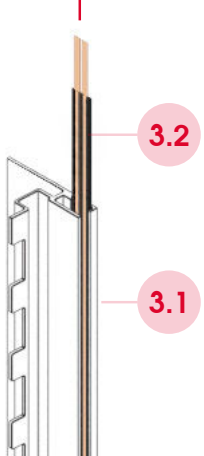

1.1 Cremallera

1.2 Carril eléctrico

2 POSIBLES MEDIDAS (30 - 45 FONDO)

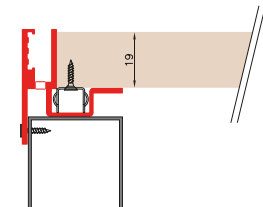
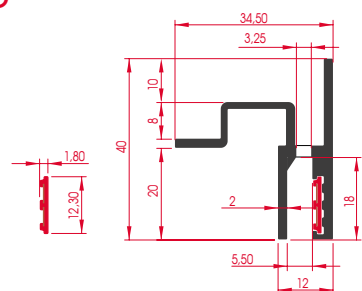
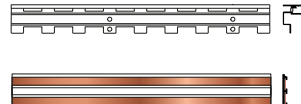



ACCESORIOS CREMALLERA ALU

● Vidrio ● Madera

ESTANTES

CARGA LIGERA



3890/1..



3891/1..



CARGA MEDIA



3894/1..



CARGA ALTA



3895/1..

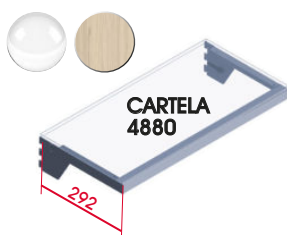

3896/1..



CARGA MEDIA



5370/00B



CARGA MEDIA



4636/1..



3898/1..



3897/1..



BARRAS

CARGA LIGERA



4901/1..



4910/1..

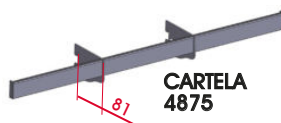

PERROQUET

CARGA LIGERA



4725/1..

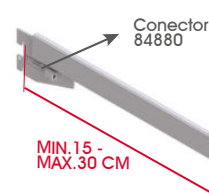



## TABLA DE PESOS

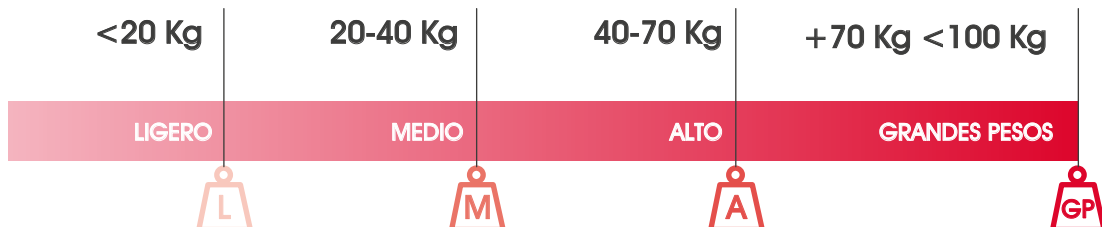

## COMPORTAMIENTO DE CARGA



Puntos conflictivos de carga



La inclinación puede variar dependiendo del peso y la flexibilidad del aluminio.

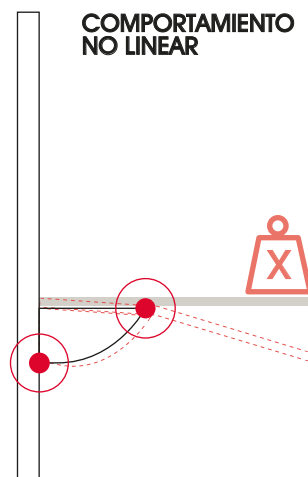
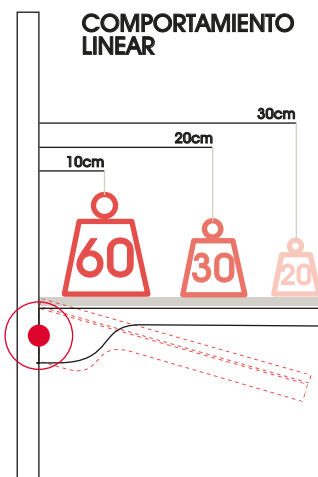

## PLUG & PLAY

AL ENCAJAR SE ENCIENDE 

Con el sistema PLUG & PLAY el montaje de los módulos de carga resulta fácil, rápido y muy práctico, ya que solo encajando las cartelas a las cremalleras, el circuito eléctrico queda totalmente conectado y el LED encendido.

- FÁCIL
- RÁPIDO
- PRÁCTICO

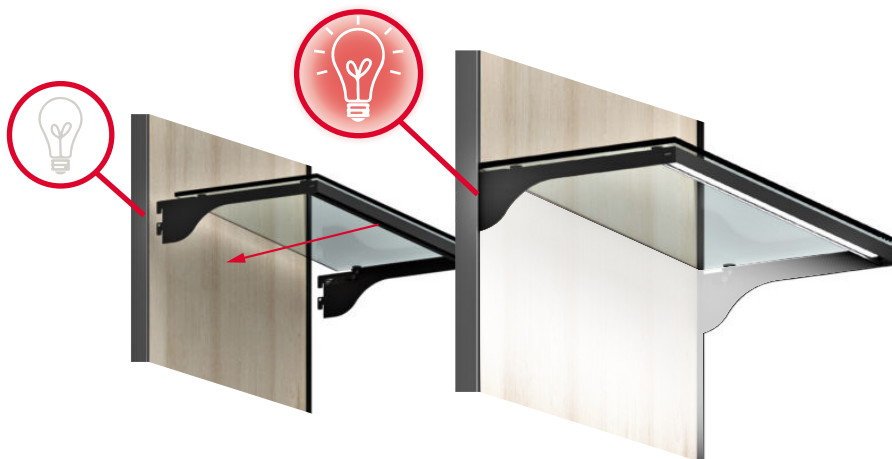



DESPIECE ACCESORIOS

PERROQUET



CARGA LIGERA

4725/1..

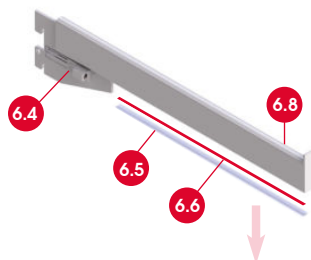

6.1 VIDRIO  
Base de  
los estantes

6.2 MADERA  
Base de  
los estantes

6.3 Cartelas

6.4 Conector

6.5 Difusor

6.6 Tira LED

6.7 Conductor  
adhesivo

6.8 Barra



BARRAS



CARGA LIGERA

4901/1..

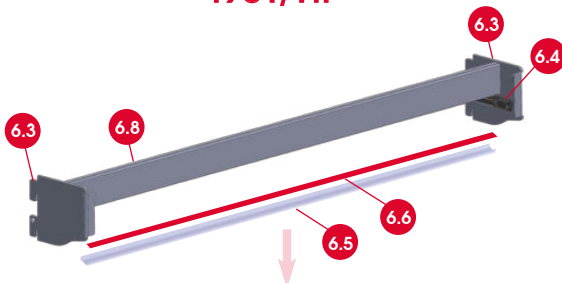

4910/1..

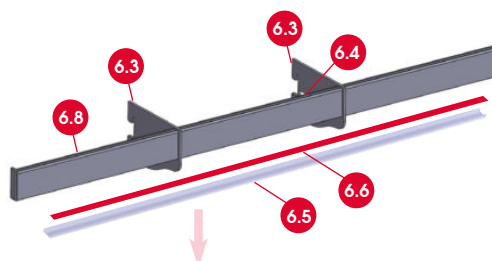

CARGA MEDIA

3898/1..

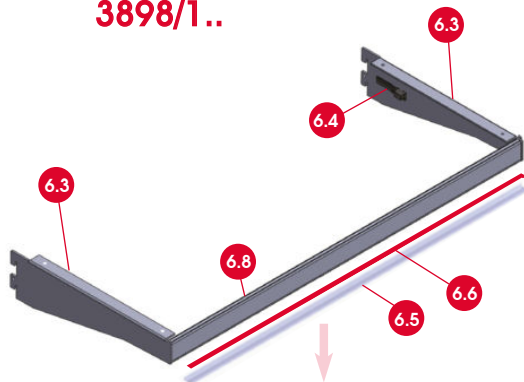

3897/1..

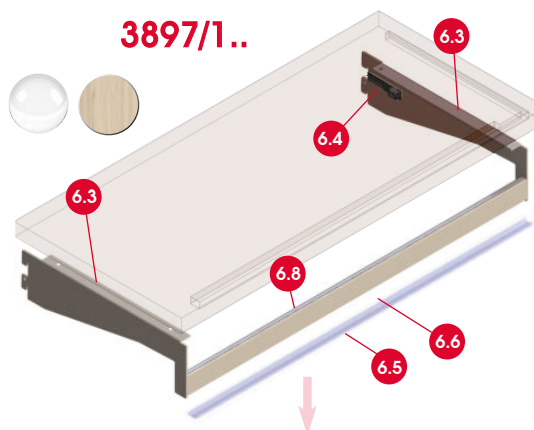



ESTANTES

Tira LED

Orientación  
de la luz



CARGA LIGERA



CARGA MEDIA

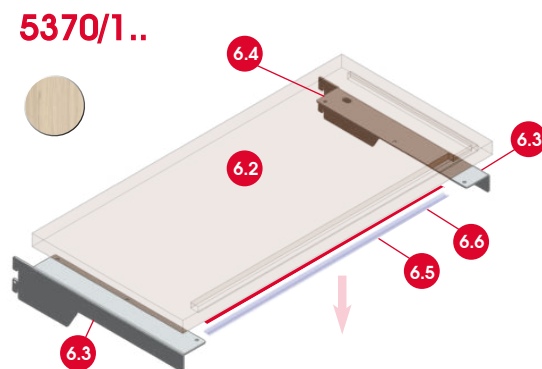
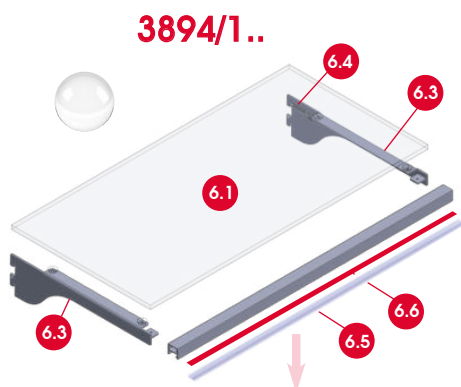

CARGA ALTA

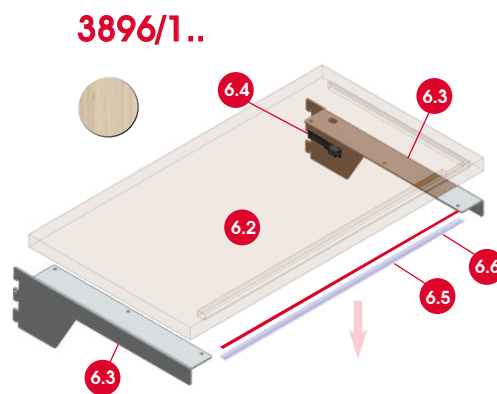
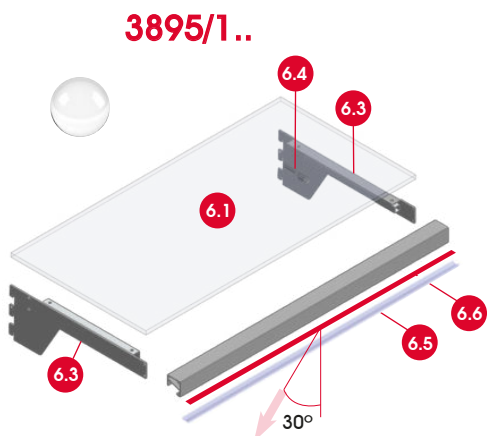



COMPONENTES POR PIEZA/METRO

CREMALLERAS

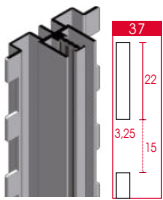

**GUÍA ELECTRIFICABLE  
PANELABLE - 2 CANALES**  
CRÉMAILLÈRE ÉLECTRIFIABLE  
AVEC DOUBLE PERFORATION  
ELECTRIFIABLE DOUBLE SLOT  
RACK  
CREMAGLIERA ELETRIFICABILE  
CON FORATURA DOPPIA  
**4870/1... 5M**  
**4870/57... 5.7M**

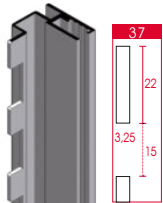
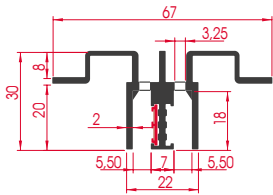

**GUÍA ELECTRIFICABLE  
PANELABLE - 1 CANAL**  
CRÉMAILLÈRE ÉLECTRIFIABLE  
AVEC SINGLE PERFORATION  
ELECTRIFIABLE SINGLE SLOT  
RACK  
CREMAGLIERA ELETRIFICABILE  
CON FORATURA SEMPLICE  
**4872/1... 5M**  
**4872/57... 5.7M**

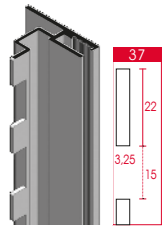
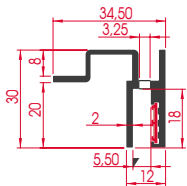

**GUÍA ELECTRIFICABLE  
PANELABLE - 1 CANAL - FINAL**  
CRÉMAILLÈRE ÉLECTRIFIABLE  
FINAL AVEC SINGLE  
PERFORATION  
FINAL ELECTRIFIABLE SINGLE  
SLOT RACK  
CREMAGLIERA ELETRIFICABILE  
FINALE CON FORATURA  
SEMPLICE  
**4874/1..**

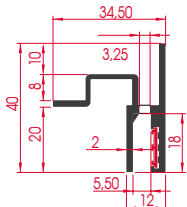

CONECTORES



**NUEVO CONECTOR  
PLUG & PLAY. BLANCO**  
CONNECTEUR PLUG & PLAY,  
BLANC  
CONNECTOR PLUG & PLAY,  
WHITE  
CONNETTORE PLUG & PLAY,  
BIANCO  
**84880/NOB**  
**84880/NON**

PL. M	BLANCO	NEGRO	COLOR
ALU. M	BLANC	NOIR	COULEUR
ALL. NAT	BIANCO	NERO	COLORE
01	0B	0N	0P

Al	5 m - 5,7 m	67x30	€/m
----	-------------	-------	-----

○	○	○	○
○	○	○	○

Al	5 m - 5,7 m	35x30	€/m
----	-------------	-------	-----

○	○	○	○
○	○	○	○

Al	5 m	35x40	€/m
----	-----	-------	-----

○	○	○	○
---	---	---	---

PLÁSTICO	PLASTIQUE	PLASTIC	PLASTICA
09			

Pla	3 m	24 W	€/u
CE IP20		Max. 3A	

○
○

CARRIL ELECTRIFICADO



**CARRIL ELECTRIFICADO SIN CABLE  
CONEXIÓN A DRIVER (1M)**  
**4871/109 1M**

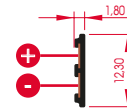

ZINCADO	INOX	SAT	PLÁSTICO
PL. ZINK	INOX	SAT	PLASTIQUE
ZINCATO	INOX	SAT	PLASTICA
34	28	09	

Max. 6A	25m	€/m
---------	-----	-----

○
---

**CABLE CON MINI-CONECTORES  
230V**  
CABLE + MINI PLUG - 230V  
CABLE + MINI PLUG - 230V  
CAVO + MINI PLUG - 230V  
**6015/00B**

Pla	3 m	230 V	€/u
		2,5 A	

○

Cable para soldar al carril 4871/109.  
CONEXIÓN CON DRIVER 6010

GRAPAS



**PANELES  
19MM GROSOR**

**ENGANCHE PARA COLGAR PANELES -  
19MM GROSOR**  
CROCHET POUR ACCROCHER  
PANNEAUX -19MM  
HOOK FOR HANGING PANELS -19MM  
GANCIO PER APPENDERE PANNELLI  
-19MM  
**4616/034**

Fe	4870-4874	€/u
----	-----------	-----

○
---



**PANELES  
10MM GROSOR**

**ENGANCHE PARA COLGAR PANELES  
-10MM GROSOR**  
CROCHET POUR ACCROCHER  
PANNEAUX - 10MM  
HOOK FOR HANGING PANELS -  
10MM  
GANCIO PER APPENDERE PANNELLI  
-10MM  
**4635/034**

Fe	4870-4874	€/u
----	-----------	-----

○
---



**PANELES  
10MM GROSOR**

**CLIPAJE PARA ENCASTRAR PANELES  
FRONTALMENTE**  
CLIPPING POUR ADAPTER LES  
PANNEAUX FRONTALEMENT  
CLIPPING TO FIT PANELS FRONTALLY  
CLIPPING PER ADATTARE I PANNELLI  
FRONTALMENTE  
**4607/028**

Fe	4870-4874	€/u
----	-----------	-----

○
---

CABLES



**CABLE MINI PLUG - ABIERTO 24V**  
CABLE MINI PLUG - OVERTE 24V  
CABLE MINI PLUG - OPEN ENDED 24V  
CAVO MINI PLUG - APERTO 24V  
**4888/009**

Pla	400 m	24 V	€/u
		2,5 A	

○
---



## SISTEMA DE FÁCIL CONEXIÓN - PLUG & PLAY

### DRIVER

PLÁSTICO  
PLASTIQUE  
PLASTIC  
PLASTICA  
**09**



6 SALIDAS

DRIVER 100W, 24V /  
CONECTOR HEMBRA  
CONDUCTEUR 100W, 24V /  
CONNECTEUR FEMELLE  
DRIVER 100W, 24V /  
FEMALE CONNECTOR  
DRIVER 100W, 24V /  
CONNETTORE FEMMINA  
**6010/009**

Pla	⚡ 24V 100W	€/u
	15cm	

CABLE CON MINI-CONECTORES  
230V  
CABLE + MINI PLUG - 230V  
CABLE + MINI PLUG - 230V  
CAVO + MINI PLUG - 230V  
**6015/00B**



Pla	⚡ 230 V	€/u
	3 m	2,5 A

CONECTOR DIVER 6 VIAS 20CM  
CONNECTEUR PLONGEUR 6  
VOIES 20CM  
6-WAY DIVER CONNECTOR  
20CM  
CONNETTORE SUBACQUEO A 6  
VIE 20 CM  
**6021/009**



Pla	⚡ 230 V	€/u
	3 m	2,5 A

CABLE ALARGO MACHO-HEMBRA 3M  
CÂBLE D'EXTENSION MÂLE-FEMELLE DE  
3 M  
3M MALE-FEMALE EXTENSION CABLE  
CAVO DI PROLUNGA  
MASCIO-FEMMINA 3M  
**6022/00B**



Pla	⚡ 230 V	€/u
	3 m	2,5 A

CON CONECTOR NUEVO



### SISTEMA CUT-LINE

PL. M.  
ALU. M.  
ALU. M.  
ALL. NAT.  
**01**

DIFERENTES  
POSICIONES  
DEL DIFUSOR  
(RECTO /  
INCLINADO)



PERFIL DE ALUMINIO CON LED  
INCORPORADO  
PROFILÉ EN ALUMINIUM AVEC LED  
INTÉGRÉE  
ALUMINIUM PROFILE WITH BUILT-IN LED  
PROFILO IN ALLUMINIO CON LED  
INTEGRATO  
**6025/301** 4000K  
**6026/301** 5000K

Pla	⚡ 3 m	€/u
	⊗CRI>90	
	9,6W24V	€/u



SET CONECTOR + TAPA  
CABLE 40CM  
**6030/041**

GRAPAS  
**6031/041**

○  
○  
○  
○

## SISTEMA DE PERFIL DE ALUMINIO CON LED INCORPORADO

SE PUEDE ENCASTRAR A LA MADERA  
O AUTOADHESIVAR

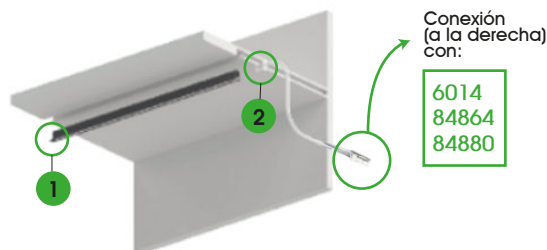

Conexión  
(a la derecha)  
con:

**6014**  
**84864**  
**84880**

### CARRIL ELECTRIFICADO



Longitud  
cable  
1m.

Gesis®  
GST0812G

CARRIL ELECTRIFICADO + CABLE  
CONEXIÓN A DRIVER (1M)  
VOIE ÉLECTRIFIÉE + CÂBLE DE  
CONNEXION A DRIVER (1M)  
ELECTRIFIED TRACK + CONNECTION  
WIRE TO DRIVER (1M)  
BINARIO ELETTRIFICATO + CAVO  
CONNESSIONE DRIVER (1M)  
**4871/259 2.5M**  
**4871/159 1.5M**

Fe	⊙ 4870- 4872 - 4874	€/u
----	------------------------	-----

○  
○

### CORTE TOTALMENTE LIBRE, SIN LIMITES DE MEDIDAS

SE CORTA TODA LA ESTRUCTURA Y EL LED  
A LA MEDIDA DESEADA Y SE REMATA  
CON LOS TAPONES FINALES POR AMBOS LADOS



1 Tapón simple / 2 Tapón con conexión (derecha)

### DISTINTAS MANERAS DE POSICIONAR EL LED

SEGÚN NECESIDAD DE DIRECCIONAR LA LUZ

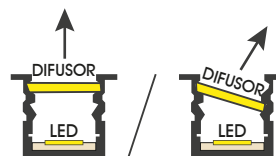

Cualquier  
manipulación invalida  
la garantía del  
fabricante





**ESTANTE**

**VIDRIO 3895/1..**

\* Recomendamos usar vidrios asegurizados o laminados. (NO INCLUIDO)

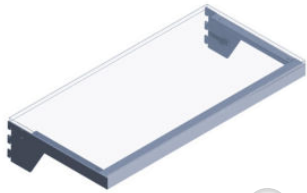

**VIDRIO \* NO INCLUIDO**

ESTANTE DE VIDRIO  
CON ILUMINACIÓN  
FRONTAL

3895/1..  
**MONTADO**

Étagère en verre avec  
éclairage avant  
Glass shelf with front  
lighting  
Ripiano vetro con  
illuminazione frontale

1M máx.  
29  
cm

PL. M ALU. M ALU. M ALL. NAT	BLANCO BLANC WHITE BIANCO	NEGRO NOIR BLACK NERO	COLOR COULEUR COLOR COLORE
01	OB	ON	OP

				€/u

**ESTANTE**

**VIDRIO 3894/1..**



**VIDRIO \* NO INCLUIDO**

ESTANTE DE VIDRIO  
CON ILUMINACIÓN  
CENTRAL FRONTAL

3894/1..  
**MONTADO**

Étagère en verre avec  
éclairage zenithal frontal  
Glass shelf with frontal  
zenithal lighting  
Ripiano di vetro con  
illuminazione zenitale  
frontale

1M máx.  
29  
cm

PLÁSTICO PLASTIQUE PLASTIC PLASTICA	BLANCO BLANC WHITE BIANCO	NEGRO NOIR BLACK NERO	COLOR COULEUR COLOR COLORE
09	OB	ON	OP

				€/u

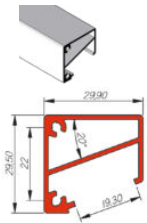

PERFIL ALUMINIO  
PROFIL EN ALUMINIUM  
ALUMINIUM PROFILE  
PROFILO DI ALUMINIO

4744/1..

Al	5 m	30x30	€/m
		84602	

PLÁSTICO PLASTIQUE PLASTIC PLASTICA
09

Pla	2 m	4744	€/m
-----	-----	------	-----



DIFUSOR PLASTICO MATE  
DIFFUSEUR EN PLASTIQUE MAT  
MATT PLASTIC DIFFUSOR  
DIFUSORE PLASTICO OPACO

84602/109

Pla	2 m	4744	€/m
-----	-----	------	-----

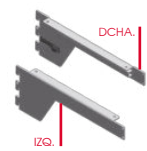
KIT CARTELAS ESTANTE VIDRIO  
CON ILUMINACIÓN  
KIT SUPPORTS VERRE  
ILUMINATION  
GLASS LIGHTING BRACKETS KIT  
KIT MENSOLE VETRO  
ILLUMINAZIONE

4880/0..

Fe	4744-2556-4890	€/u
	292 mm medida útil	

Cada cartela  
tiene 2 taladros  
para usar 1 perfil  
4744

Kit 2 cartelas:  
DERECHA (con  
conector) +  
IZQUIERDA



126 diodos (20λ);  
cortable cada  
5,5 cm  
Cable, fil. wire,  
cavo: 26cm  
Ancho 8mm

flexible y con  
cinta adhesiva  
fleible and  
self-adhesive

LED CON  
MINI-CONECTOR 24V  
BANDE LED AVEC  
MINI-PLUG 24V  
LED STRIP WITH  
MINI-PLUG 24V  
STRACIA LED CON  
MINI-PLUG 24V

4890/109

Pla	1 m	5000 K	€/u
		CRI>90	9,6 W 24V

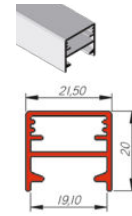
PERFIL ALUMINIO  
PROFIL EN ALUMINIUM  
ALUMINIUM PROFILE  
PROFILO DI ALUMINIO

4748/1..

Al	6 m	21,5x20	€/m
		4893	



DIFUSOR PLASTICO MATE  
DIFFUSEUR EN PLASTIQUE MAT  
MATT PLASTIC DIFFUSOR  
DIFUSORE PLASTICO OPACO

4893/109

Pla	2 m	4748	€/m
-----	-----	------	-----



KIT CARTELAS ESTANTE VIDRIO  
CON ILUMINACIÓN  
KIT SUPPORTS VERRE  
ILUMINATION  
GLASS LIGHTING BRACKETS KIT  
KIT MENSOLE VETRO  
ILLUMINAZIONE

4891/0..

Fe	4744-2556-4890	€/u
	292 mm medida útil	

Kit 2 cartelas:  
DERECHA (con  
conector) +  
IZQUIERDA



126 diodos (20λ);  
cortable cada  
5,5 cm  
Cable, fil. wire,  
cavo: 26cm  
Ancho 8mm

flexible y con  
cinta adhesiva  
fleible and  
self-adhesive

LED CON  
MINI-CONECTOR 24V  
BANDE LED AVEC  
MINI-PLUG 24V  
LED STRIP WITH  
MINI-PLUG 24V  
STRACIA LED CON  
MINI-PLUG 24V

4890/109

Pla	1 m	5000 K	€/u
		CRI>90	9,6 W 24V



VENTOSA TRANSPARENTE  
VENTOUSE  
SUCTION  
VENTOSA

2556/009

Pla	Ø14 mm	4880	€/u
-----	--------	------	-----



VENTOSA TRANSPARENTE  
VENTOUSE  
SUCTION  
VENTOSA

2556/009

Pla	Ø14 mm	4891	€/u
-----	--------	------	-----



ESTANTE

VIDRIO 3890/1..

\* Recomendamos usar vidrios segurizados o laminados. (NO INCLUIDO)



VIDRIO \*  
NO INCLUIDO

ESTANTE DE VIDRIO  
RETROILUMINADO  
\*3890/1..  
**MONTADO**

Étagère en verre extra  
claire rétro-éclairé  
Blacklit optical glass shelf  
Ripiano vetro extralight  
retroilluminato

1M máx.  
30  
cm

PL M	BLANCO	NEGRO	COLOR
ALU. M	BLANC	NOIR	COULEUR
ALL. NAT	WHITE	BLACK	COLOR
	BANCO	NERO	COLORE
01	0B	0N	0P

€/u

\*o \*o \*o

ESTANTE

VIDRIO 3891/1..



VIDRIO \*  
NO INCLUIDO

ESTANTE DE  
VIDRIO CON  
ILUMINACIÓN  
FRONTAL  
\*3891/1..  
**MONTADO**

Étagère en verre avec  
éclairage zénithal frontal  
Glass shelf with frontal  
zenithal lighting  
Ripiano di vetro con  
illuminazione zenitale  
frontale

1M máx.  
30  
cm

PL M	BLANCO	NEGRO	COLOR
ALU. M	BLANC	NOIR	COULEUR
ALL. NAT	WHITE	BLACK	COLOR
	BANCO	NERO	COLORE
01	0B	0N	0P

€/u

\*o \*o \*o



junta goma incluida  
joint en caoutchouc  
inclus rubber gasket  
included giunta di  
gomma inclusa

PERFIL ALUMINIO  
PROFIL LAME  
D'ALUMINIUM  
ALUMINIUM SLATWALL  
PROFILE  
PROFILO DOGATO  
ALLUMINIO  
\*362/1...

Al	5 m	6-8mm	€/m
361/109			

\*o \*o \*o \*o

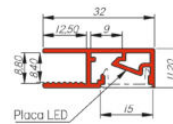
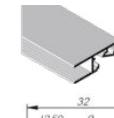

PERFIL ALUMINIO  
PROFIL EN ALUMINIUM  
ALUMINIUM PROFILE  
PROFILO DI ALLUMINIO  
4892/1..

Al	5 m	32x11,2	€/m
4893 -4894			

o o o o



Para perfil 362  
Kit 2 cartelas:  
DERECHA (con  
conector) +  
IZQUIERDA

KIT CARTELAS ESTANTE  
VIDRIO CON  
ILUMINACIÓN  
KIT SUPPORTS VERRE  
ILUMINATION  
GLASS LIGHTING  
BRACKETS KIT  
KIT MENSOLE VETRO  
ILLUMINAZIONE  
\*386/0..

Fe	362 - 4890	€/u
68 mm medida útil		

\*o \*o \*o

PLÁSTICO  
PLASTIQUE  
PLASTIC  
PLASTICA  
09



DIFUSOR DE PLÁSTICO MATE  
DIFFUSEUR EN PLASTIQUE MAT  
MATT PLASTIC DIFUSOR  
DIFUSORE PLASTICO OPACO  
4893/109

Pla	4892 -4894	€/m
2 m		

o



126 diodos (20λ);  
cortable cada  
5,5 cm  
Cable, fil, wire,  
cavo: 26cm  
Ancho 8mm

flexible y con  
cinta adhesiva  
fleible and  
self-adhesive

LED CON  
MINI-CONECTOR 24V  
BANDE LED AVEC  
MINI-PLUG 24V  
LED STRIP WITH  
MINI-PLUG 24V  
STRACIA LED CON  
MINI-PLUG 24V  
4890/109

Pla	1 m	5000 K	€/u
CRI>90	9,6 W	24V	

o

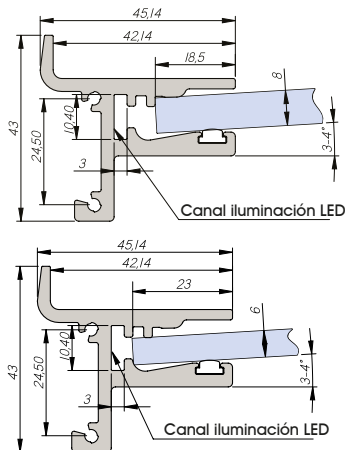

• MÁXIMA  
MEDIDA ESTANTE  
RECOMENDADA:  
100 X 30 CM.

• Maximum  
recommended  
shelf size: 100 x  
30 cm.

• Dimensione  
massima  
raccomandata  
dello scaffale:  
100 x 30 cm.

• Taille  
maximale de  
l'étagère  
recommandée:  
100 x 30 cm.



### ESTANTE

### MADERA 3896/1..

\* MADERA NO INCLUIDA

PL. M	BLANCO	NEGRO	COLOR
ALU. M	BLANC	NOR	COULEUR
ALU. M	WHITE	BLACK	COLOR
ALL. NAT	BIANCO	NERO	COLORE
01	0B	0N	0P

ESTANTE DE MADERA CON ILUMINACIÓN FRONTAL EMPOTRADA Y PERFIL DE ALUMINIO (3971)  
**3896/1..**

#### SIN MONTAJE

Étagère en bois avec éclairage zénithal monté sur l'étagère  
Wooden shelf with zenithal lighting mounted on the shelf  
Ripiano legno con illuminazione zenitale imbotrata nel ripiano

1M máx.  
35 cm

€/u



MADERA NO INCLUIDA

### ESTANTE

### MADERA 5370/1..

PL. M	BLANCO	NEGRO	COLOR
ALU. M	BLANC	NOR	COULEUR
ALU. M	WHITE	BLACK	COLOR
ALL. NAT	BIANCO	NERO	COLORE
01	0B	0N	0P

ESTANTE DE MADERA CON ILUMINACIÓN FRONTAL EMPOTRADA Y PERFIL DE ALUMINIO (3971)  
**\*5370/1..**

#### SIN MONTAJE

Étagère en bois avec éclairage zénithal monté sur l'étagère  
Wooden shelf with zenithal lighting mounted on the shelf  
Ripiano legno con illuminazione zenitale imbotrata nel ripiano

1M máx.  
29 cm

€/u



MADERA NO INCLUIDA \*

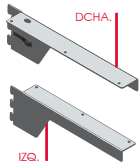

**KIT CARTELAS ESTANTE MADERA CON ILUMINACIÓN**  
KIT SUPPORTS BOIS ILUMINATION  
WOOD LIGHTING BRACKETS KIT  
KIT MENSOLE LEGNO ILLUMINAZIONE  
**4885/0..**

Fe	4890	€/u
350 mm medida útil		

Kit 2 cartelas: DERECHA (con conector) + IZQUIERDA



**KIT PERFIL ALUMINIO CON DIFUSOR**  
KIT PROFIL EN ALUMINIUM AVEC DIFFUSEUR  
KIT PROFILO IN ALLUMINIO CON DIFFUSORE  
**3971/1..**

Al	2 m	18x9	€/m
----	-----	------	-----

Fresar la madera e insertar

Medidas mecanizado 16 x 6.8 mm



**LED CON MINI-CONECTOR 24V**  
BANDE LED AVEC MINI-PLUG 24V  
LED STRIP WITH MINI-PLUG 24V  
STRACIA LED CON MINI-PLUG 24V  
**4890/009**

Pla	1 m	5000 K	€/u
CRI > 90 9,6 W 24V			

126 diodos (20λ): cortable cada 5,5 cm  
Cable, fil. wire, cavo: 40cm  
Ancho 8 mm  
flexible y con cinta adhesiva feible and self-adhesive

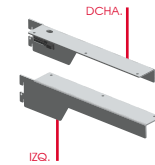

**KIT CARTELAS ESTANTE MADERA CON ILUMINACIÓN**  
KIT SUPPORTS BOIS ILUMINATION  
WOOD LIGHTING BRACKETS KIT  
KIT MENSOLE LEGNO ILLUMINAZIONE  
**\*5370/0..**

Fe	4890	€/u
290 mm medida útil		

Kit 2 cartelas: DERECHA (con conector) + IZQUIERDA



**KIT PERFIL ALUMINIO CON DIFUSOR**  
KIT PROFIL EN ALUMINIUM AVEC DIFFUSEUR  
KIT PROFILO IN ALLUMINIO CON DIFFUSORE  
**3971/1..**

Al	2 m	18x9	€/m
----	-----	------	-----

Fresar la madera e insertar

Medidas mecanizado 16 x 6.8 mm



**LED CON MINI-CONECTOR 24V**  
BANDE LED AVEC MINI-PLUG 24V  
LED STRIP WITH MINI-PLUG 24V  
STRACIA LED CON MINI-PLUG 24V  
**4890/009**

Pla	1 m	5000 K	€/u
CRI > 90 9,6 W 24V			

126 diodos (20λ): cortable cada 5,5 cm  
Cable, fil. wire, cavo: 40cm  
Ancho 8 mm  
flexible y con cinta adhesiva feible and self-adhesive

### SISTEMA CUT-LINE

PL. M	BLANCO	NEGRO	COLOR
ALU. M	BLANC	NOR	COULEUR
ALU. M	WHITE	BLACK	COLOR
ALL. NAT	BIANCO	NERO	COLORE
01			



**PERFIL DE ALUMINIO CON LED INCORPORADO**  
PROFILÉ EN ALUMINIUM AVEC LED INTÉGRÉE  
ALUMINUM PROFILE WITH BUILT-IN LED  
PROFILO IN ALLUMINIO CON LED INTEGRATO

6025/301 4000K  
6026/301 5000K

**SET CONECTOR + TAPA**  
CABLE 40CM  
6030/041

**GRAPAS**  
6031/041

Pla	3 m	€/u
CRI > 90 9,6 W 24V		

DIFERENTES POSICIONES DEL DIFUSOR (RECTO / INCLINADO)



### SISTEMA DE PERFIL DE ALUMINIO CON LED INCORPORADO SE PUEDE ENCASTRAR A LA MADERA O AUTOADHESIVAR

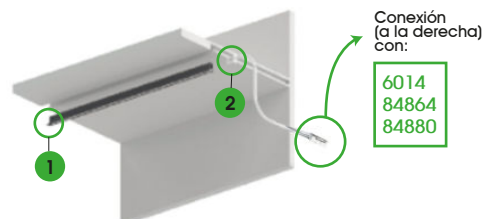

Conexión (a la derecha) con:

6014  
84864  
84880

### CORTE TOTALMENTE LIBRE, SIN LIMITES DE MEDIDAS

SE CORTA TODA LA ESTRUCTURA Y EL LED A LA MEDIDA DESEADA Y SE REMATA CON LOS TAPONES FINALES POR AMBOS LADOS





**BARRA ACCESORIOS  
FRONTAL 4910/1..**

PL. M ALU. M ALL. NAT	BLANCO BLANC WHITE BIANCO	NEGRO NOR BLACK NERO	COLOR COULEUR COLOR COLORE
01	0B	0N	0P

CARGA LIGERA



Kit compuesto por:  
- Cartelas Ref.4875  
-Tubo rectangular  
Ref.4900/10B  
-LED de 1m

1M máx.  
8 cm

BARRA DE CUELGUE PARA  
ACCESORIOS FRONTALES CON  
ILUMINACIÓN Y PROTECCIÓN  
PLÁSTICA

4910/1..

**MONTADO**

Barre de suspension pour  
accessoires avant avec  
éclairage  
Hanger bar for front  
accessories with lighting  
Barra appendiabilt per  
accessori frontali con  
illuminazione

€/u

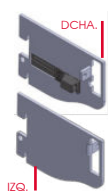

Kit 2 cartelas:  
DERECHA (con  
conector) +  
IZQUIERDA

**KIT CARTELAS BARRA  
ACCESORIOS**

**KIT SUPPORT BARRE  
ACCESOIRES**  
**KIT BRACKET FOR  
ACCESSORIES ROD**  
**KIT MENSOLA TUBO  
PORTA-ACCESSORI**

4875/00.

Fe	⊙4900	€/u
	81 mm medida útil	

o o o

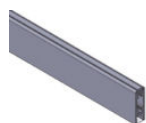

LED no incluido.  
LED  
recomendado de  
5mm de ancho.  
Incluye perfil de  
plástico superior y  
difusor interior.

**TUBO RECTANGULAR PARA  
ILUMINACIÓN 30X10MM  
CON PLETINA DE REFUERZO**  
**KIT TUBE RECTANGULAIRE  
POUR ECLAIRAGE 30X10MM  
AVEC PLAQUE DE RENFORT**  
**KIT RECTANGULAR TUBE FOR  
LIGHTING 30X10MM WITH  
REINFORCING PLATE**  
**KIT TUBO RETTANGOLARE PER  
ILLUMINAZIONE 30X10MM  
CON PIASTRA DI RINFORZO**

4900/12.

Al	⊔ 1 m	30x10	€/u
	⊙4901/109		

o o o o



Para perfil  
4900

**TAPA PARA TUBO  
RECTANGULAR 30X10MM**  
**CAPUCHON DE TUBE  
RECTANGULAIRE**  
**30X10MM TUBE CAP**  
**RECTANGULAR 30X10MM**  
**TAPPO DEL TUBO**  
**RETTANGOLARE 30X10MM**

4904/0..

Fe	92 mm	⊙4900	€/u
----	-------	-------	-----

o o o o

PLÁSTICO  
PLASTIQUE  
PLASTICA  
09



182 diodos (20λ);  
cortable cada  
3.8 cm  
Cable, fil. wire,  
cavo: 40cm  
Ancho 5mm

flexible y con  
cinta adhesiva  
fleible and  
self-adhesive

**LED CON MINI-CONECTOR 24V**  
**BANDE LED AVEC MINI-PLUG**  
**24V**  
**LED STRIP WITH MINI-PLUG 24V**  
**STRACIA LED CON MINI-PLUG**  
**24V**

4910/109

Pla	⊔ 1 m	⚡ 5000 K	€/u
	⊙CRI>90	⊙15,3W 24V	

o

**BARRA ACCESORIOS  
FRONTAL 4901/1..**

PL. M ALU. M ALL. NAT	BLANCO BLANC WHITE BIANCO	NEGRO NOR BLACK NERO	COLOR COULEUR COLOR COLORE
01	0B	0N	0P

CARGA LIGERA

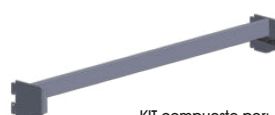

Kit compuesto por:  
- Cartelas Ref.4878  
-Tubo rectangular  
Ref.4900/10B  
-LED de 1m

1M máx.  
7 cm

BARRA DE CUELGUE PARA  
ACCESORIOS FRONTALES  
CON ILUMINACIÓN Y  
PROTECCIÓN PLÁSTICA  
SUPERIOR

4901/1..

**MONTADO**

Barre de suspension pour  
accessoires avant avec éclairage  
Hanger bar for front accessories  
with lighting  
Barra appendiabilt per accessori  
frontali con illuminazione

€/u

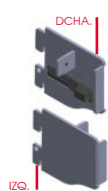

Kit 2 cartelas:  
DERECHA (con  
conector) +  
IZQUIERDA

**KIT CARTELAS BARRA ACCESORIOS**  
**KIT SUPPORT BARRE ACCESOIRES**  
**KIT BRACKET FOR  
ACCESSORIES ROD**  
**KIT MENSOLA TUBO  
PORTA-ACCESSORI**

4878/00.

Fe	⊙4900	€/u
	68 mm medida útil	

o o o

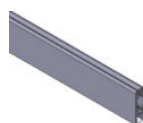

LED no incluido.  
LED  
recomendado de  
5mm de ancho.  
Incluye perfil de  
plástico superior y  
difusor interior.

**TUBO RECTANGULAR PARA  
ILUMINACIÓN 30X10MM  
CON PLETINA DE REFUERZO**  
**KIT TUBE RECTANGULAIRE  
POUR ECLAIRAGE 30X10MM  
AVEC PLAQUE DE RENFORT**  
**KIT RECTANGULAR TUBE FOR  
LIGHTING 30X10MM WITH  
REINFORCING PLATE**  
**KIT TUBO RETTANGOLARE PER  
ILLUMINAZIONE 30X10MM  
CON PIASTRA DI RINFORZO**

4900/12.

**CON ALMA DE  
ACERO INOX**

**CARGA LIGERA**  
max. 30KG

Al	⊔ 1 m	30x10	€/u
	⊙4901/109		

o o o o



182 diodos (20λ);  
cortable cada  
3.8 cm  
Cable, fil. wire,  
cavo: 45 mm  
Ancho 5mm

flexible y con  
cinta adhesiva  
fleible and  
self-adhesive

**LED CON MINI-CONECTOR 24V**  
**BANDE LED AVEC MINI-PLUG 24V**  
**LED STRIP WITH MINI-PLUG 24V**  
**STRACIA LED CON MINI-PLUG**  
**24V**

4901/109

Pla	⊔ 1 m	⚡ 5000 K	€/u
	⊙CRI>90	⊙15,3W 24V	

PLÁSTICO  
PLASTIQUE  
PLASTICA  
09

o

**EJEMPLO DE APLICACIÓN**

Barras de  
accesorios con  
carga frontal.

**NO APTO PARA  
PERROQUET  
SOLO GANCHO**

**CARGA LIGERA**

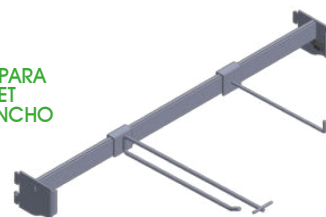



### PENDERIE 3897/1..

- \* MADERA NO INCLUIDA
- \* Recomendamos usar vidrios asegurizados o laminados. (NO INCLUIDO)

CARGA LIGERA



VIDRIO / MADERA NO INCLUIDO



ESTANTE + BARRA DE CUELQUE LATERAL CON ILUMINACIÓN Y PROTECCIÓN PLÁSTICA SUPERIOR

**3897/1..**

**MONTADO**  
Tablette + barre de suspension latérale avec éclairage  
Shelf + side hanging bar with lighting  
Mensola + barra appendiabili laterale con illuminazione

1M máx. 29 cm

PARA MADERA O VIDRIO

PL. M ALU. M ALL. M ALL. NAT	BLANCO WHITE BLANCO	NEGRO NOR BLACK NERO	COLOR COULEUR COLOR COLORE
01	OB	ON	OP

### BARRA DE CUELQUE LATERAL 3898/1..

CARGA LIGERA



BARRA DE CUELQUE LATERAL CON ILUMINACIÓN Y PROTECCIÓN PLÁSTICA SUPERIOR

**3898/1..**

**MONTADO**  
Barre de suspension latérale avec éclairage  
Side hanger bar with lighting  
Barra appendiabili laterale con illuminazione

1M máx. 29 cm

PL. M ALU. M ALL. M ALL. NAT	BLANCO WHITE BLANCO	NEGRO NOR BLACK NERO	COLOR COULEUR COLOR COLORE
01	OB	ON	OP

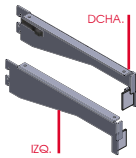

Kit 2 cartelas: DERECHA (con conector) + IZQUIERDA

**KIT CARTELAS BARRA CUELQUE CON ESTANTE**  
KIT SUPPORT BARRE ACCESSOIRES  
KIT BRACKET FOR ACCESSORIES ROD  
KIT MENSOLA TUBO PORTA-ACCESSORI

**4727/0..**

Fe	4900	€ / u
	290 mm medida útil	

Al	1 m	30x10	€ / u
	4901		

**TUBO RECTANGULAR PARA ILUMINACIÓN 30X10MM CON PLETINA DE REFUERZO**  
KIT TUBE RECTANGULAIRE POUR ECLAIRAGE 30X10MM AVEC PLAQUE DE RENFORT  
KIT RECTANGULAR TUBE FOR LIGHTING 30X10MM WITH REINFORCING PLATE  
KIT TUBO RETTANGOLARE PER ILLUMINAZIONE 30X10MM CON PIASTRA DI RINFORZO

**4900/12.**  
CON ALMA DE ACERO INOX

**CARGA LIGERA**  
max. 30KG

--	--	--	--

Pla	1 m	5000 K	€ / u
		CRI > 90	15,3W 24V

PLÁSTICO PLASTIQUE PLASTIC PLASTICA  
**09**

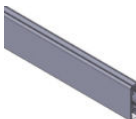

LED no incluido. LED recomendado de 5mm de ancho. Incluye perfil de plástico superior y difusor interior.



182 diodos (20λ); cortable cada 3.8 cm  
Cable, fil, wire, cavo: 40cm  
Ancho 5mm

flexible y con cinta adhesiva flexible and self-adhesive

**LED CON MINI-CONECTOR 24V**  
BANDE LED AVEC MINI-PLUG 24V  
LED STRIP WITH MINI-PLUG 24V  
STRIACIA LED CON MINI-PLUG 24V

**4910/109**

Pla	1 m	5000 K	€ / u
		CRI > 90	15,3W 24V

PLÁSTICO PLASTIQUE PLASTIC PLASTICA  
**09**

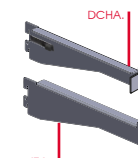

Kit 2 cartelas: DERECHA (con conector) + IZQUIERDA

**KIT CARTELAS BARRA CUELQUE ACCESORIOS**  
KIT SUPPORT BARRE ACCESSOIRES  
KIT BRACKET FOR ACCESSORIES ROD  
KIT MENSOLA TUBO PORTA-ACCESSORI

**4726/0..**

Fe	4900	300 mm	€ / u
		290 mm medida útil	

Al	1 m	30x10	€ / u
	4901/109		

**TUBO RECTANGULAR PARA ILUMINACIÓN 30X10MM CON PLETINA DE REFUERZO**  
KIT TUBE RECTANGULAIRE POUR ECLAIRAGE 30X10MM AVEC PLAQUE DE RENFORT  
KIT RECTANGULAR TUBE FOR LIGHTING 30X10MM WITH REINFORCING PLATE  
KIT TUBO RETTANGOLARE PER ILLUMINAZIONE 30X10MM CON PIASTRA DI RINFORZO

**4900/12.**  
CON ALMA DE ACERO INOX

**CARGA LIGERA**  
max. 30KG

--	--	--	--

Pla	1 m	5000 K	€ / u
		CRI > 90	15,3W 24V

PLÁSTICO PLASTIQUE PLASTIC PLASTICA  
**09**

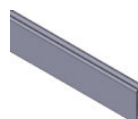

LED no incluido. LED recomendado de 5mm de ancho. Incluye perfil de plástico superior y difusor interior.



182 diodos (20λ); cortable cada 3.8 cm  
Cable, fil, wire, cavo: 40cm  
Ancho 5mm

flexible y con cinta adhesiva flexible and self-adhesive

**LED CON MINI-CONECTOR 24V**  
BANDE LED AVEC MINI-PLUG 24V  
LED STRIP WITH MINI-PLUG 24V  
STRIACIA LED CON MINI-PLUG 24V

**4910/109**

Pla	14 mm	4726	€ / u
-----	-------	------	-------

Pla	3 m	€ / u
		CRI > 90

--	--	--	--

--	--	--	--

--	--	--	--

--	--	--	--

--	--	--	--

DIFERENTES POSICIONES DEL DIFUSOR (RECTO / INCLINADO)

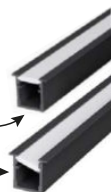

**PERFIL DE ALUMINIO CON LED INCORPORADO**  
PROFILÉ EN ALUMINIUM AVEC LED INTÉGRÉE  
ALUMINIUM PROFILE WITH BUILT-IN LED  
PROFILO IN ALLUMINIO CON LED INTEGRATO

**6025/301** 4000K

**6026/301** 5000K

**SET CONECTOR + TAPA CABLE 40CM**  
**6030/041**

**GRAPAS**

**6031/041**





PERROQUET

4725/0..

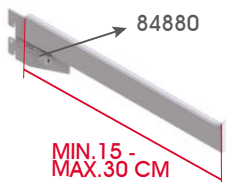

MIN.15 -  
MAX.30 CM

PERROQUET PLANO CON  
ILUMINACIÓN PARA  
CUELQUE FRONTAL

4725/0..

MONTADO

Chien plat avec éclairage  
pour suspension avant  
Flat doggie with lighting  
for front hanging  
Cagnolino piatto con  
illuminazione per  
sospensione frontale

Fe 300 mm

PL. M	BLANCO	NEGRO	COLOR
ALU. M	BLANC	NOR	COULEUR
ALL. NAT	WHITE	BLACK	COLOR
	BANCO	NERO	COLORE
01	0B	0N	0P

€/u

CARTELAS

4636/0..



ESTANTE VOLADO DE  
MADERA CON ILUMINACIÓN  
DE GROSOR 19MM

KIT CARTELAS  
4636/1..

SIN MONTAJE

Étagère en bois avec  
éclairage, épaisseur 19 mm  
Wooden shelf with lighting,  
19mm thick  
Mensola in legno con  
illuminazione, spessore 19  
mm

MADERA \*  
NO INCLUIDA

Fe 3971

PL. M	BLANCO	NEGRO	COLOR
ALU. M	BLANC	NOR	COULEUR
ALL. NAT	WHITE	BLACK	COLOR
	BANCO	NERO	COLORE
01	0B	0N	0P

€/u

SISTEMA CUT-LINE

DIFERENTES  
POSICIONES  
DEL DIFUSOR  
(RECTO /  
INCLINADO)



PERFIL DE ALUMINIO CON LED  
INCORPORADO  
PROFILÉ EN ALUMINIUM AVEC LED  
INTÉGRÉE  
ALUMINIUM PROFILE WITH BUILT-IN LED  
PROFILO IN ALLUMINIO CON LED  
INTEGRATO

6025/301 4000K  
6026/301 5000K



SET CONECTOR + TAPA  
CABLE 40CM  
6030/041

GRAPAS  
6031/041

PL. M  
ALU. M  
ALL. NAT  
01

Pla 3 m  
CRI > 90  
9,6W24V €/u

€/u

SISTEMA DE PERFIL DE ALUMINIO CON LED  
INCORPORADO

SE PUEDE ENCASTRAR A LA MADERA O AUTOADHESIVAR

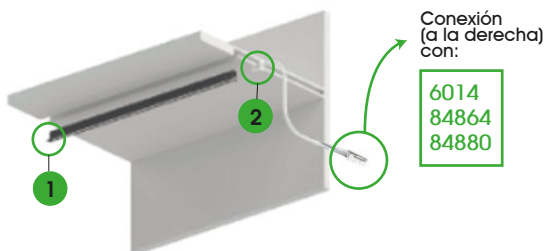

Conexión  
(a la derecha)  
con:

6014  
84864  
84880

CORTE TOTALMENTE LIBRE, SIN LIMITES DE MEDIDAS

SE CORTA TODA LA ESTRUCTURA Y EL LED A LA MEDIDA DESEADA  
Y SE REMATA CON LOS TAPONES FINALES POR AMBOS LADOS

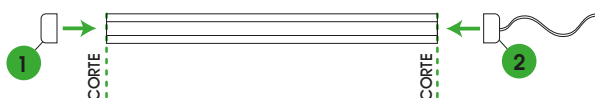

1 Tapón simple / 2 Tapón con  
conexión  
(derecha)



Kit 2 cartelas:  
DERECHA (con  
conector) +  
IZQUIERDA



Medidas  
mecanizado  
16 x 6.8 mm



126 diodos (20λ):  
cortable cada 5.5 cm  
Cable, fil., wire, cavo:  
26cm / Ancho 8mm  
flexible y con cinta  
adhesiva  
flexible and  
self-adhesive

KIT CARTELAS ESTANTE  
MADERA CON ILUMINACIÓN  
KIT SUPPORTS BOIS  
ILUMINATION  
WOOD LIGHTING BRACKETS  
KIT  
KIT MENSOLE LEGNO  
ILLUMINAZIONE

4636/0..

KIT PERFIL ALUMINIO CON  
DIFUSOR  
KIT PROFIL EN ALUMINIUM  
AVEC DIFFUSEUR  
KIT PROFILO IN ALLUMINIO  
CON DIFFUSORE

3971/1..

LED CON MINI-CONECTOR  
24V  
BANDE LED AVEC MINI-PLUG  
24V  
LED STRIP WITH MINI-PLUG  
24V  
STRACIA LED CON  
MINI-PLUG 24V

4890/109

Fe 4890  
350 mm medida útil  
€/u

Al 2 m 18x9 €/m

Pla 1 m 5000 K  
CRI > 90 9,6 W 24V €/u

PLÁSTICO  
PLASTIQUE  
PLASTIC  
PLASTICA  
09

€/u



CARTELA DER

Kit 2 cartelas 4636  
DER. - Con conector  
IZQ. - Sin conector



KADÍ PHARMA - ELEKTRIC





INSTAL  
ILUMINACIÓN



KADÍ ELEKTRIC  
PHARMA C.209



ESCANEA ESTE QR  
PARA VER TODAS  
LAS IMÁGENES DEL  
SISTEMA PHARMA



KADÍ  
PHARMA  
ELEKTRIC

Ejemplos orientativos  
de distintas posibilidades,  
distribuciones y  
aplicaciones



## EXPLOSIONADO GENERAL



## MONTAJE EN SERIE

Colocar las cremalleras **ELECTRIFICADAS** EN EL LADO DERECHO de cada panel

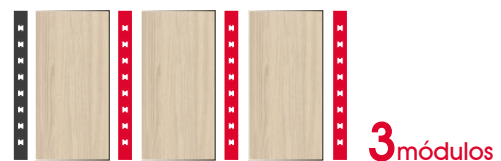

REF: 4786  
+ 4862 (CARRIL ELEKTRIC)

Tubos  
electrificados

Solo los orificios  
izquierdos  
(representados  
en rojo) están  
electrificados.

REF: 4786

Tubos  
sin carril  
eléctrico

**1** Cremallera  
electrificada  
1 o 2 caras

1C REF: 4786  
+4862

2C REF: 4787  
+4863



**2** Cremallera  
sin carril  
eléctrico  
1 o 2 caras

1C REF: 4786  
2C REF: 4787

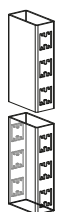

**3** Grapas para  
colgar  
paneles

2 posibles  
modelos:



**4** Tirantes



**5** Pies  
autoportantes



**6** Paneles  
(Propuesta  
de material)



**7** Accesorios

Personalizable:  
- Estantes  
- Barras  
- Letreros



## MONTAJE CON EL SISTEMA -> MAGNETIC

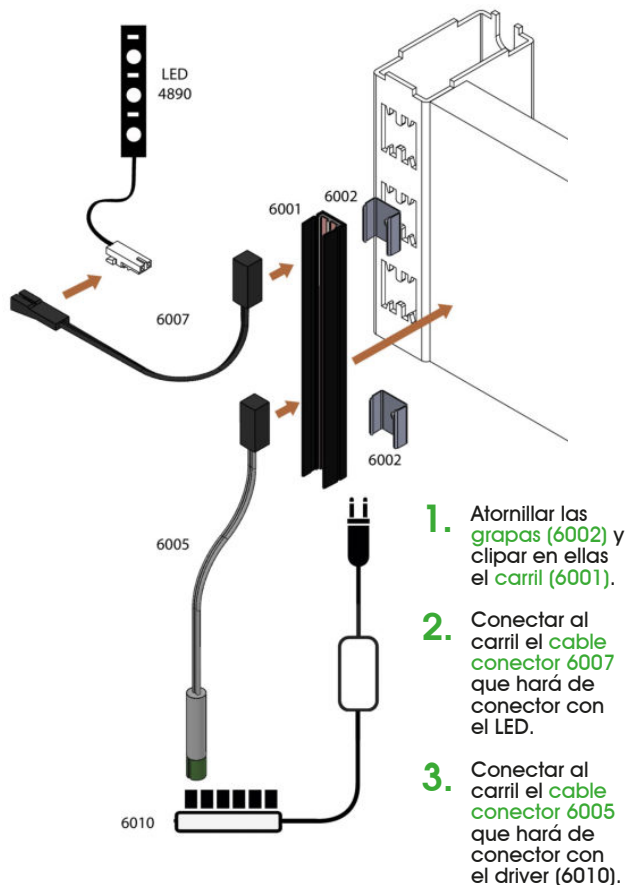

\* Los cables conectores se fijan con imán automáticamente al acercar las boquillas imantadas al carril (6001).

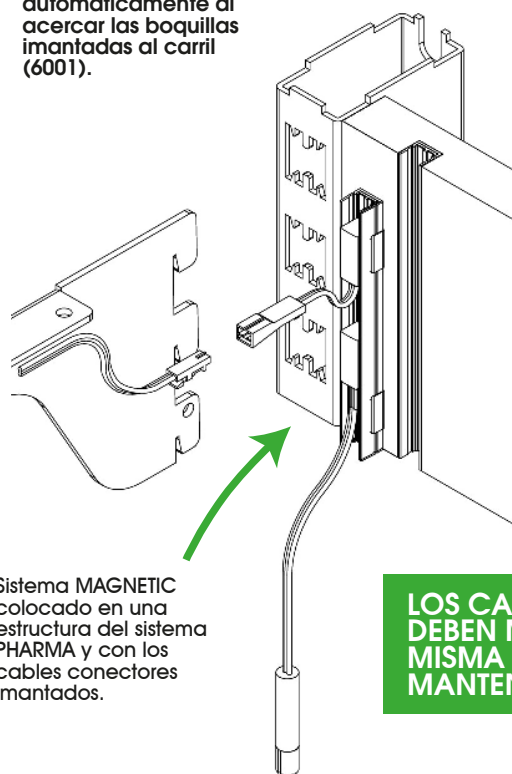

## MONTAJE CON EL SISTEMA -> EASY

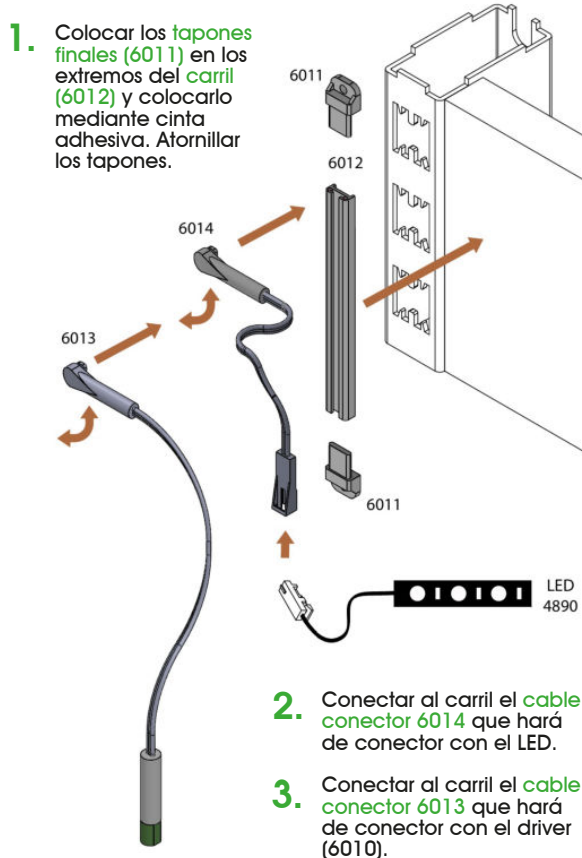

\* Los cables conectores entran con la boquilla en perpendicular y al realizar un cuarto de giro (quedando alineados con el carril) quedan totalmente fijados.

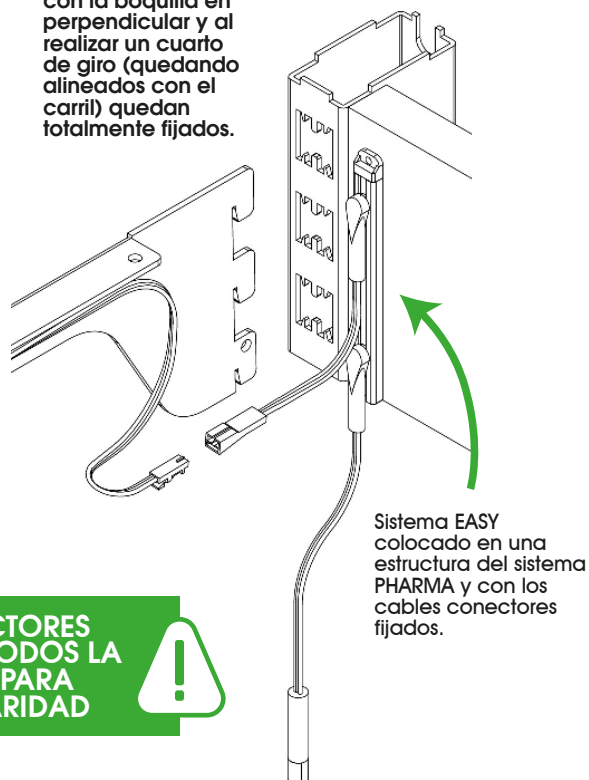

LOS CABLES CONECTORES DEBEN MANTENER TODOS LA MISMA DIRECCIÓN PARA MANTENER LA POLARIDAD





## MONTAJE DE LOS PLAFONES A LAS CREMALLERAS

### CARACTERÍSTICAS DEL SISTEMA

- Compatible con la mayoría de accesorios del sistema Kadí
- Módulos de 512, 730 y 820 mm entre ejes de columna
- Posibilidad de regular altura de estantes independientemente.
- Sistema modular que permite la combinación de 3 soluciones:

### SYSTEM FEATURES

- Compatible with most Kadí system accessories
- Modules 512, 730 and 820 mm column between axes
- Possibility to adapt height of independent shelves
- Modular system that allows the combination of 3 solutions:

### CARATTERISTICHE DEL SISTEMA

- Compatibile con la maggior parte degli accessori del sistema Kadí
- Moduli di 512, 730 e 820 mm fra assi dei montanti
- Possibilità di altezze regolari di mensole indipendenti
- sistema modulare che permette la combinazione di 3 soluzioni:

### CARACTÉRISTIQUES DU SYSTÈME

- Compatible avec la plupart des accessoires Kadí
- Modules de 512, 730 et 820 mm empattement colonne
- Possibilité de hauteur régulière des étagères indépendantes
- Système modulaire qui permet la combinaison de 3 solutions:

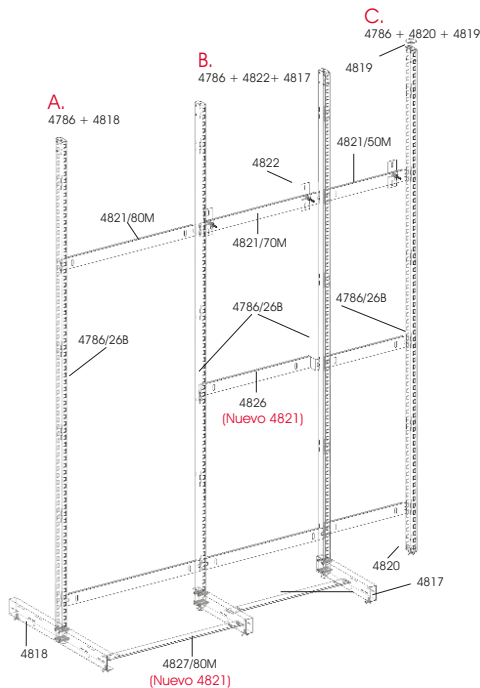

### Solución GÓNDOLA

Solution GONDOLA  
Solution GONDOLA  
soluzione GONDOLA

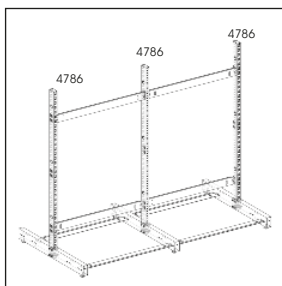

### Solución GÓNDOLA ó PARED DIVISORIA

Solution GONDOLA ou PARI SEPARATRICE  
Solution GONDOLA or PARTITION WALL  
soluzione GONDOLA o parete divisoria

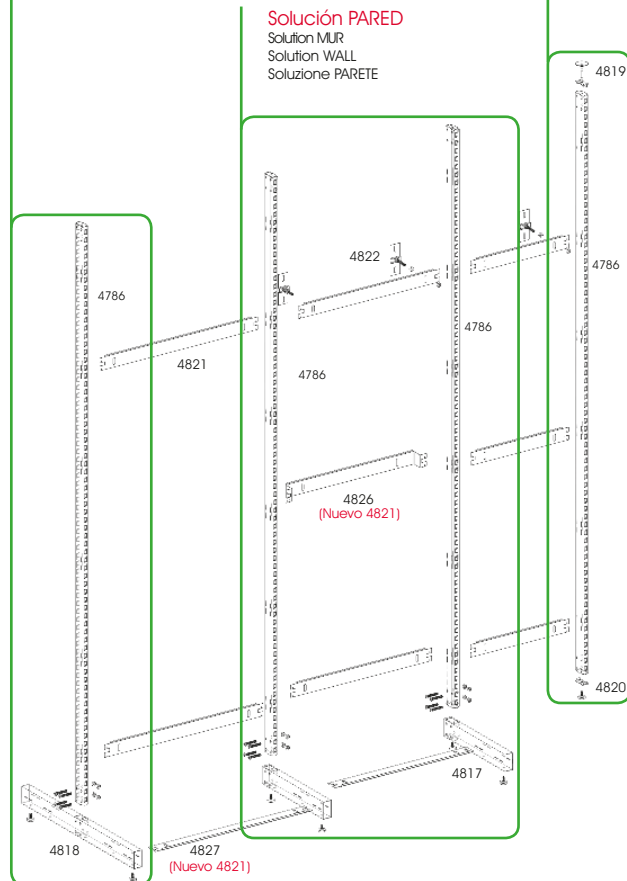

### Solución PARED

Solution MUR  
Solution WALL  
Soluzione PARETE

### Solución TECHO-SUELO

Solution SOL-PLAFOND  
Solution CEILING-FLOOR  
Soluzione SUOLO-SOFFITTO

### 4821 TIRANTES EN PLANO DIFERENTES

El uso de tirantes de unión en planos diferentes confiere más estabilidad a la góndola.

La utilisation de tirants dans de planes différents donne plus de stabilité à la góndola.

The use of rods spacer in different planes gives more stability to the gondola.

L'impiego di tiranti su piani differenti conferisce maggiore stabilità alla gondola.

### 4827 TIRANTE PARA PIES

**NUEVOS TIRANTES 4821**  
(APTOS PARA PIES Y MONTANTES)

El uso de tirantes de unión en planos diferentes confiere más estabilidad a la góndola.

La utilisation de tirants dans la base donne plus de stabilité à la gondola.

The use of rods spacer in the base gives more stability to the gondola.

L'impiego di tiranti nella base conferisce maggiore stabilità alla gondola.

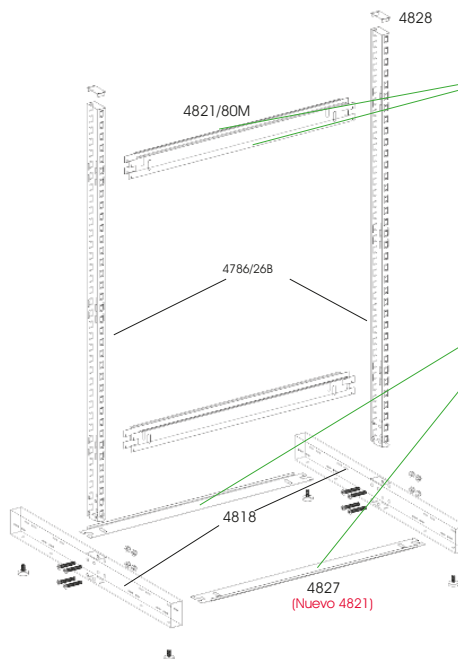

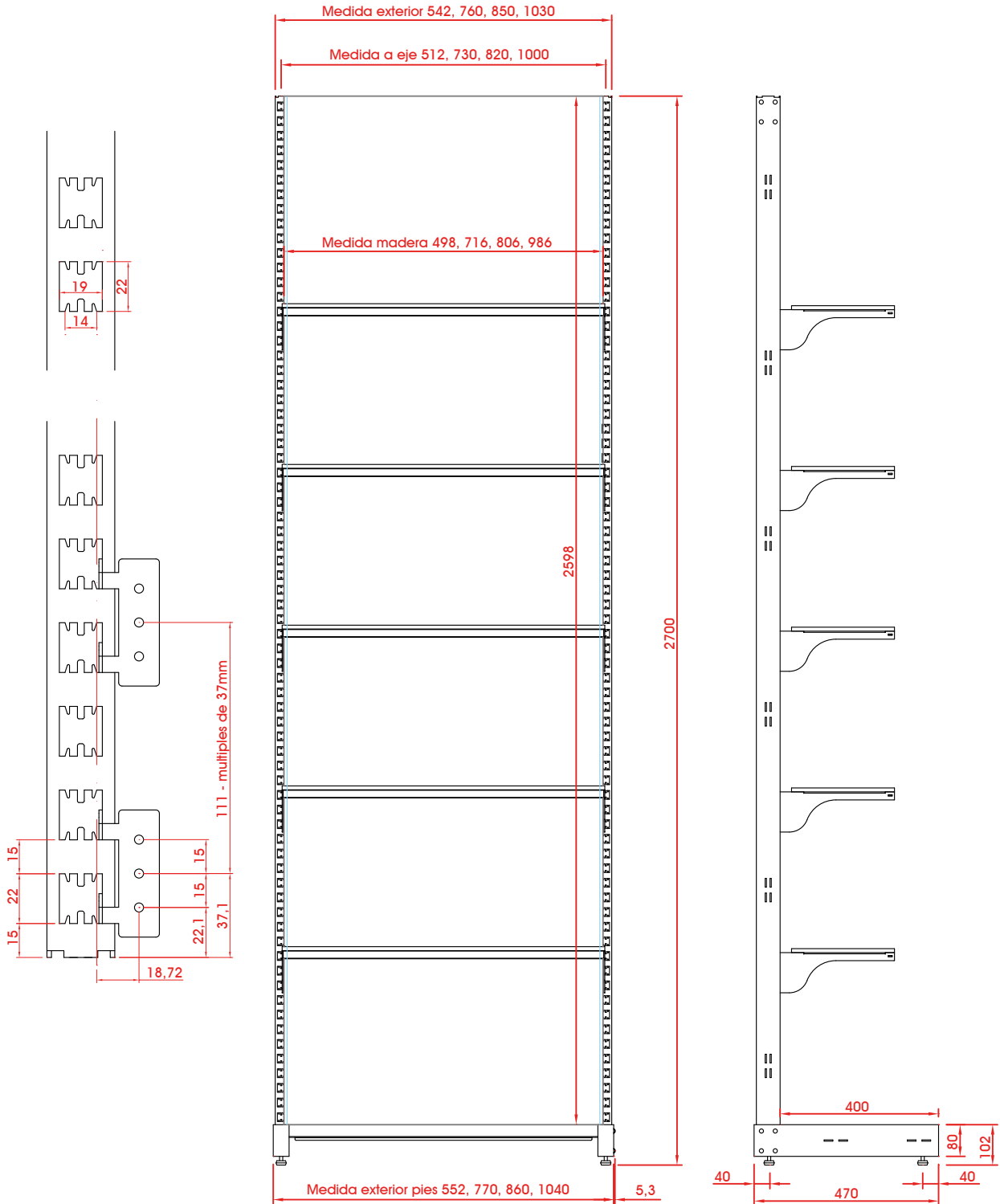



## TOPE, GRAPAS Y CABLE

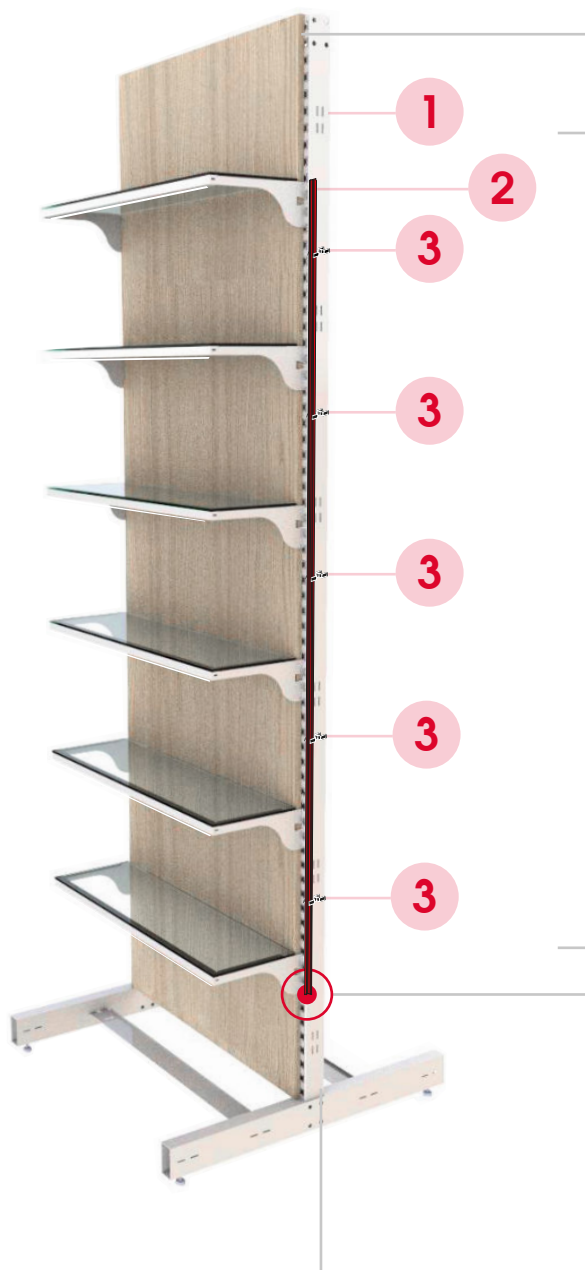

### Para paneles de máx. 16mm

Pour les panneaux max. 16mm  
For max panels 16mm  
Per pannelli massimi 16mm

#### 3 Grapas de plástico



- Las grapas deben ir repartidas de manera equitativa
- Colocar entre 4 y 8 grapas dependiendo de la medida.
- Tanto el tubo Pharma ( 1 ) como el carril electrificado ( 2 ) se pueden adaptar a cualquier medida. Posibilidad de cortar.

### INICIO DEL CARRIL ELECTRIFICADO

#### 4 Tope inferior

El tope inferior puede colocarse en cualquier orificio de la cremallera

Crema el inicio del carril electrificado

El carril queda apoyado al tope

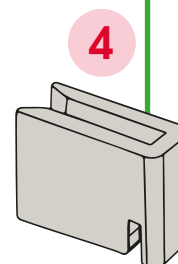
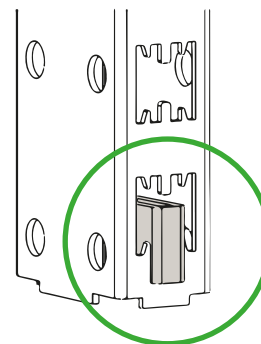

Orificio de salida del cable eléctrico por la parte trasera inferior del tubo.

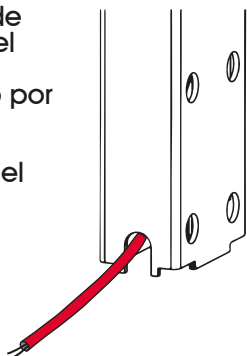



CARRIL  
ELECTRICO

1 Tubo  
Pharma  
60x30

2 Carril  
eléctrico

3 Grapas  
de plástico

4 Tope  
inferior

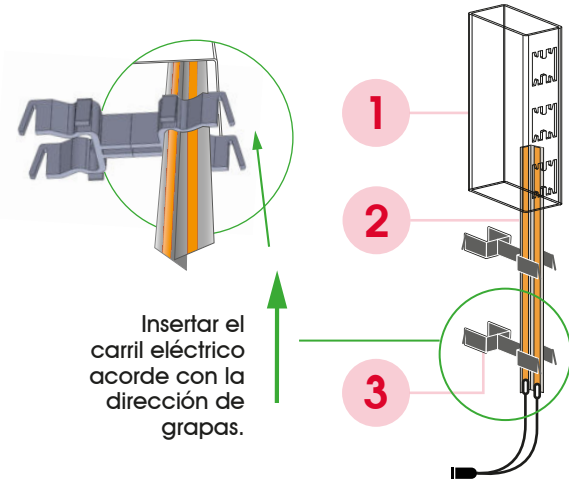

CREMALLERA ELECTRIFICADA  
1 CARA

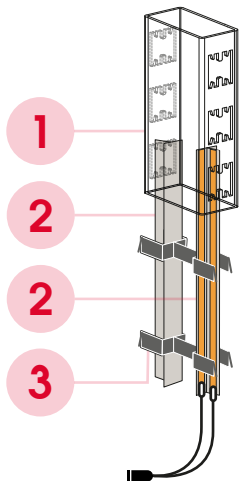
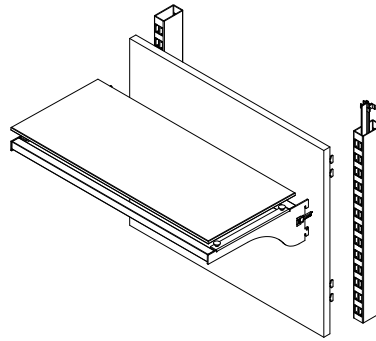

CREMALLERA ELECTRIFICADA  
2 CARAS

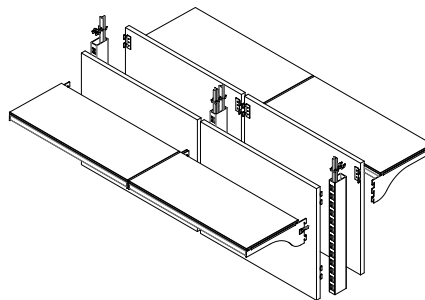

COLOCACIÓN DEL CONECTOR

5 Conector

6 Grapas  
de fijación  
para el conector



CARRIL-CABLE

- El carril electrificado lleva soldado el cable de conexión en la parte inferior. En el caso de precindir de este conector, prestar atención a la polaridad de los cables para el correcto funcionamiento de la nueva conexión.

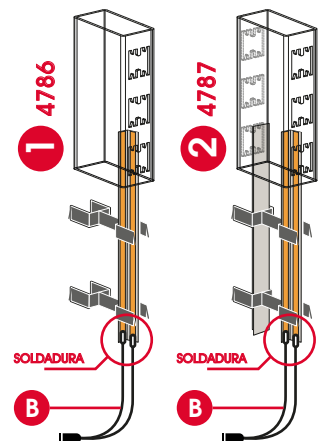



**ACCESORIOS PHARMA**

Vidrio 
  Madera 
  Diferentes materiales y acabados

**ESTANTES**

CARGA LIGERA



**6890..**



**NUEVO**

**6891..**



**NUEVO**

CARGA MEDIA



**5894..**



**NUEVO**

**5896..**



**NUEVO**

CARGA ALTA



**5895..**



**NUEVO**

**BARRAS**

CARGA LIGERA



**5898..**



**NUEVO**

**5901..**



**NUEVO**

CARGA MEDIA



**5897..**



**NUEVO**

**PORTA ROTULOS**

CARGA LIGERA



**5391**



**NUEVO**



## TABLA DE PESOS

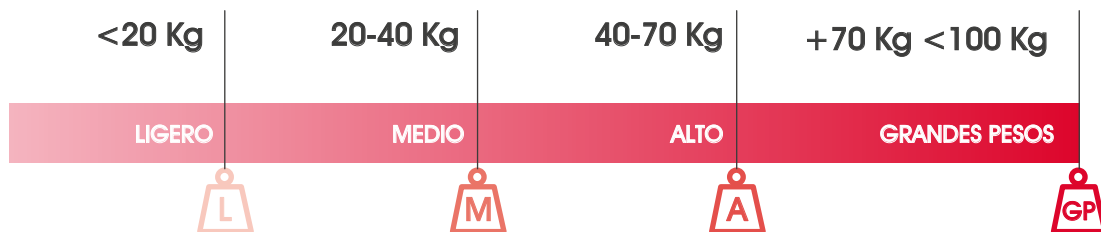

## COMPORTAMIENTO DE CARGA

● Puntos conflictivos de carga



La inclinación puede variar dependiendo del peso y la flexibilidad del aluminio.

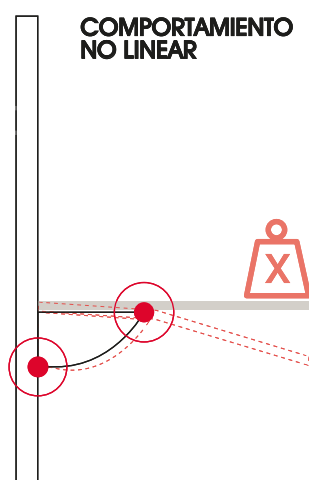
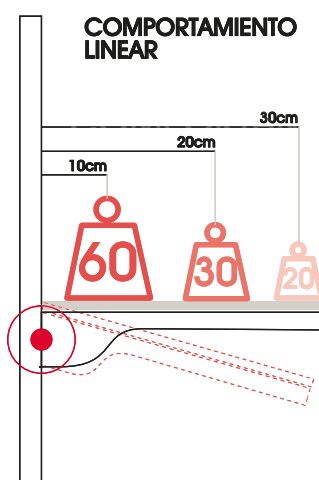

## PLUG & PLAY

AL  
ENCAJAR  
SE ENCIENDE 

Con el sistema PLUG & PLAY el montaje de los módulos de carga resulta fácil, rápido y muy práctico, ya que solo encajando las cartelas a las cremalleras, el circuito eléctrico queda totalmente conectado y el LED encendido.

- FÁCIL
- RÁPIDO
- PRÁCTICO





## COMPONENTES POR PIEZA/METRO

### CREMALLERAS

**1 CARA**

**1 CARA**  
COLUMNA TROQUELADA  
1 CARA  
COLONNE PERFORATION SIMPLE  
1 CÔTÉ  
UPRIGHT SINGLE SLOT CHANNEL  
1 SIDE  
TUBO PERFORAZIONE SEMPLICE  
1 LATO  
**4786/26B** 2678MM

**2 CARAS**

**2 CARAS**  
COLUMNA TROQUELADA  
2 CARAS  
COLONNE PERFORATION SIMPLE  
2 CÔTÉS  
UPRIGHT SINGLE SLOT CHANNEL  
2 SIDES  
PIANTANA PERFORAZIONE  
SINGOLA 2 LATI  
**4787/26B** 2678MM  
**4787/13B** 1337MM

PLANTA

ZINCADO BLANCO  
PL. ZINK BLANC  
ZINK PL. WHITE  
ZINCATO BIANCO

**34 0B**

Fe 60x30x2mm €/u

Fe 60x30x2mm €/u

### GRAPAS



**ANCLAJES PANELES MADERA**  
CROCHET PANNEAUX EN BOIS  
HOOK WOOD PANELS  
GANCIO PER PANNELLI IN LEGNO  
**4823/034**

**ANCLAJES METACRILATO Y VIDRIO**  
SUPPORT MÉTHACRYLATE ET VERRE  
METHACRYLATE AND GLASS SUPPORT  
SUPPORTOPER PLEXIGLAS E VETRO  
**4824/034**

Fe 4814 - 4815 €/u

Fe 6-8mm €/u

### MAGNETIC LED

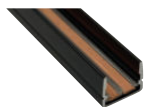

MAGNÉTICO

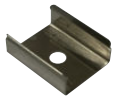

MAGNÉTICO



MAGNÉTICO



MAGNÉTICO



MAGNÉTICO

**CARRIL ELECTRIFICADO  
MAGNÉTICO**  
RAIL ÉLECTRIFIÉ MAGNÉTIQUE  
MAGNETIC ELECTRIFIED RAIL  
BINARIO ELETRIFICATO  
MAGNETICO  
**6001/20N**

**CLIP PARA FIJACIÓN**  
CLIP DE FIXATION  
FIXING CLIP  
CLIP DI FISSAGGIO  
**6002/028**

**CONECTOR MAGNÉTICO  
CARRIL-DRIVER**  
CONNECTEUR MAGNÉTIQUE  
RAIL-DRIVER  
MAGNETIC CONNECTOR  
RAIL-DRIVER  
CONNETTORE MAGNETICO  
RAIL-DRIVER  
**6005/00N**

**CONECTOR MAGNÉTICO  
CARRIL-CONECTOR CARTELAS KADÍ**  
CONNECTEUR MAGNÉTIQUE  
RAIL-CONNECTEUR SUPPORT KADI  
MAGNETIC CONNECTOR  
RAIL-CONNECTOR KADI BRACKET  
CONNETTORE MAGNETICO BINARIO  
- CONNETTORE MENSOLA KADI  
**6006/00N**

**CONECTOR MAGNÉTICO  
CARRIL-LED UNIVERSAL**  
CONNECTEUR MAGNÉTIQUE  
RAIL-LED UNIVERSAL  
MAGNETIC CONNECTOR  
RAIL-UNIVERSAL LED  
CONNETTORE MAGNETICO  
BINARIO-UNIVERSALE LED  
**6007/00N**

INOX SAT NEGRO  
INOX SAT NOIR  
S.S.S. BLACK  
INOX SAT NERO

**28 0N**

2 m €/u

6001-6012 €/u

Pla 2A €/u  
150cm

Pla 2A €/u  
40cm

Pla 2A €/u  
40cm

### DRIVER



6 SALIDAS

**DRIVER 100W, 24V /  
CONECTOR HEMBRA**  
CONDUCTEUR 100W, 24V /  
CONNECTEUR FEMELLE  
DRIVER 100W, 24V / FEMALE CONNECTOR  
DRIVER 100W, 24V / CONNETTORE FEMMINA  
**6010/009**

**CABLE CON MINI-CONECTORES  
230V**  
CABLE + MINI PLUG - 230V  
CABLE + MINI PLUG - 230V  
CAVO + MINI PLUG - 230V  
**6015/00B**

**CONECTOR DRIVER 6 VÍAS 20CM**  
CONNECTEUR PLONGEUR 6  
VOIES 20CM  
6-WAY DRIVER CONNECTOR  
20CM  
CONNETTORE SUBACQUEO A 6  
VIE 20 CM  
**6021/009**

**CABLE ALARGO MACHO-HEMBRA 3M**  
CÂBLE D'EXTENSION MÂLE-FEMELLE DL  
3 M  
3M MALE-FEMALE EXTENSION CABLE  
CAVO DI PROLUNGA  
MASCIO-FEMMINA 3M  
**6022/00B**

PLÁSTICO  
PLASTIQUE  
PLASTIC  
PLASTICA

**09**

Pla 24V 100W €/u  
15cm

Pla 3 m €/u  
230 V 2,5 A

Pla 3 m €/u  
230 V 2,5 A

Pla 3 m €/u  
230 V 2,5 A

### CON CONECTOR NUEVO



### CABLES



**CABLE MINI PLUG - ABIERTO 24V**  
CABLE MINI PLUG - OVERTE 24V  
CABLE MINI PLUG - OPEN ENDED 24V  
CAVO MINI PLUG - APERTO 24V  
**4888/009**

Pla 400 m €/u  
24 V 2,5 A

### EASY



**CARRIL ELECTRIFICADO  
RAIL ÉLECTRIFIÉ**  
ELECTRIFIED RAIL  
BINARIO ELETRIFICATO  
**6012/25.**

2,5 m 24V €/u

Para instalaciones  
movibles permite  
quita y pon  
MAGNÉTICO



**CINTA MAGNÉTICA ADHESIVA**  
RUBAN MAGNÉTIQUE ADHÉSIF  
ADHESIVE MAGNETIC TAPE  
NASTRO MAGNETICO ADESIVO  
**6012/000** 50M  
**6012/100** 1M

PLÁSTICO  
PLASTIQUE  
PLASTIC  
PLASTICA

**09**

€/u  
€/m



**CINTA ADHESIVA DOBLE CARA**  
RUBAN MAGNÉTIQUE ADHÉSIF  
ADHESIVE MAGNETIC TAPE  
NASTRO MAGNETICO ADESIVO  
**6012/009** 66M

€/u



**CONECTOR CARRIL-DRIVER/  
CONECTOR SEGURIDAD ALUSYSTEM**  
CONNECTEUR RAIL-DRIVER /  
CONNECTEUR SÉCURITÉ DU ALUSYSTEM  
CONNECTOR RAIL-DRIVER /  
CONNECTOR ALUSYSTEM SECURITY  
CONNETTORE RAIL-DRIVER /  
CONNETTORE LA SICUREZZA ALUSYSTEM  
**6013/0..**

Pla 24V €/u  
1M



**CONECTOR CARRIL-LED / HEMBRA**  
CONNECTEUR RAIL-LED / FEMELLE  
RAIL-LED CONNECTOR / FEMALE  
CONNETTORE RAIL-LED / FEMMINA  
**6014/0..**

Pla 24V €/u  
10cm



(x2 u.)

**TAPÓN FINAL**  
BOUCHON D'EXTRÉMITÉ  
END CAP  
TAPPO TERMINALE  
**6011/0..** SET 2 U.

€/u



COMPONENTES POR PIEZA/METRO

KITS CARRIL ELECTRIFICADO

KIT  
1CARA



KIT PERFIL DE ALUMINIO  
ELECTRIFICADO A UNA CARA  
CON GRAPAS DE PLÁSTICO  
KIT PROFILÉ ALUMINIUM  
ÉLECTRIFIÉ D'UN CÔTÉ AVEC DES  
AGRAFES EN PLASTIQUE  
KIT ALUMINIUM PROFILE  
ELECTRIFIED ON ONE SIDE WITH  
PLASTIC STAPLES  
KIT PROFILO IN ALLUMINIO  
ELETRIFICATO SU UN LATO CON  
GRAFFE IN PLASTICA

4862/024 240 CM  
4862/018 180 CM  
4862/012 120 CM

Fe 55x26mm €/m

PL. M  
ALU. M  
ALL. NAT  
01

Nº COMPONENTES/MEDIDA

MEDIDA	240 cm	180 cm	120 cm
<b>Grapas</b>	X8 uds	X6 uds	X4 uds
<b>Carril electrificado</b>	1 carril de 240	1 carril de 180	1 carril de 120
<b>Tope inferior</b>	X1 ud	X1 ud	X1 ud

KIT  
2CARAS



KIT PERFIL DE ALUMINIO  
ELECTRIFICADO CON GRAPAS  
DE PLÁSTICO  
KIT PROFILÉ ALUMINIUM  
ÉLECTRIFIÉ DOUBLE FACE AVEC  
CLIPS EN PLASTIQUE  
KIT DOUBLE-SIDED ELECTRIFIED  
ALUMINIUM PROFILE WITH  
PLASTIC CLIPS  
KIT PROFILO IN ALLUMINIO  
ELETRIFICATO BIFACCIALE CON  
CLIPS IN PLASTICA

4863/024 240 CM  
4863/018 180 CM  
4863/012 120 CM

Fe 55x26mm €/m

Nº COMPONENTES/MEDIDA

MEDIDA	240 cm	180 cm	120 cm
<b>Grapas</b>	X8 uds	X6 uds	X4 uds
<b>Carril electrificado</b>	2 carriles de 240	2 carriles de 180	2 carriles de 120
<b>Tope inferior</b>	X2 uds	X2 uds	X2 uds

SISTEMA DE FÁCIL CONEXIÓN - PLUG & PLAY

KITS CARRIL ELECTRIFICADO

KIT  
1CARA

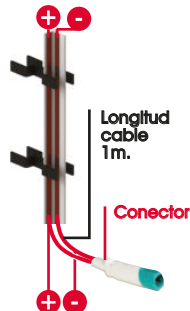

KIT PERFIL DE ALUMINIO  
ELECTRIFICADO A UNA CARA  
CON GRAPAS DE PLÁSTICO  
KIT PROFILÉ ALUMINIUM  
ÉLECTRIFIÉ D'UN CÔTÉ AVEC DES  
AGRAFES EN PLASTIQUE  
KIT ALUMINIUM PROFILE  
ELECTRIFIED ON ONE SIDE WITH  
PLASTIC STAPLES  
KIT PROFILO IN ALLUMINIO  
ELETRIFICATO SU UN LATO CON  
GRAFFE IN PLASTICA

4862/X24 240 CM  
4862/X18 180 CM  
4862/X12 120 CM

Fe 55x26mm €/m

PL. M  
ALU. M  
ALL. NAT  
01

Nº COMPONENTES/MEDIDA

MEDIDA	240 cm	180 cm	120 cm
<b>Grapas</b>	X8 uds	X6 uds	X4 uds
<b>Carril electrificado</b>	1 carril de 240	1 carril de 180	1 carril de 120
<b>Tope inferior</b>	X1 ud	X1 ud	X1 ud
<b>Conector</b>	X1 ud	X1 ud	X1 ud

KIT  
2CARAS

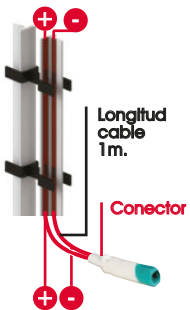

KIT PERFIL DE ALUMINIO  
ELECTRIFICADO CON GRAPAS  
DE PLÁSTICO  
KIT PROFILÉ ALUMINIUM  
ÉLECTRIFIÉ DOUBLE FACE AVEC  
CLIPS EN PLASTIQUE  
KIT DOUBLE-SIDED ELECTRIFIED  
ALUMINIUM PROFILE WITH  
PLASTIC CLIPS  
KIT PROFILO IN ALLUMINIO  
ELETRIFICATO BIFACCIALE CON  
CLIPS IN PLASTICA

4863/X24 240 CM  
4863/X18 180 CM  
4863/X12 120 CM

Fe 55x26mm €/m

Nº COMPONENTES/MEDIDA

MEDIDA	240 cm	180 cm	120 cm
<b>Grapas</b>	X8 uds	X6 uds	X4 uds
<b>Carril electrificado</b>	2 carriles de 240	2 carriles de 180	2 carriles de 120
<b>Tope inferior</b>	X2 uds	X2 uds	X2 uds
<b>Conector</b>	X2 uds	X2 uds	X2 uds

CONECTORES

COMPATIBLE KADÍ PRIMO

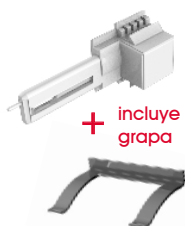

+ incluye grapa

CONECTOR PLUG & PLAY,  
BLANCO / NEGRO  
CONNECTEUR PLUG & PLAY,  
BLANC / NOIR  
CONNECTOR PLUG & PLAY,  
WHITE / BLACK  
CONNETTORE PLUG & PLAY,  
BIANCO / NERO

84864/00B  
84864/00N

PLÁSTICO  
PLASTIQUE  
PLASTIC  
PLASTICA  
09

Pla 1 m  
CE IP20  
24V max.3A €/u

Cualquier  
manipulación invalida  
la garantía del  
fabricante





**PIES Y ANCLAJES**

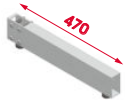

**PIE AUTOPORTANTE A PARED**  
 PIED AUTOPORTANT MUR  
 SELF-SUPPORTING FOOD  
 BASE AUTOPORTANTE A PARETE  
**4817/00B**

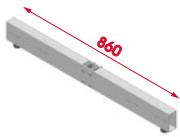

**PIE AUTOPORTANTE GÓNDOLA**  
 PIED GONDOLA  
 GONDOLA FOOD  
 BASE GONDOLA  
**4818/00B**



**ANCLAJE TECHO-SUELO**  
 VÉRIN SUPÉRIEUR  
 UPPER LEVEL  
 LIVELLATORE SUPERIORE  
**4819/00B**



**BASE COLUMNA**  
 VÉRIN INFÉRIEUR  
 LOWER LEVEL  
 LIVELLATORE INFERIORE  
**4820/00B**



**KIT DE Z CON RUEDA DE ALTA RESISTENCIA**  
 KIT Z AVEC ROUE ROBUSTE  
 Z KIT WITH HEAVY DUTY WHEEL  
 Z KIT CON RUOTA PER SERVIZIO PESANTE  
**4818/R0B**



**FIJACIÓN TIRANTES A PARED**  
 PATTES DE FIXATION  
 ROD-SPACER WALL SUPPORT  
 FISSAGIO TIRANTI A PARED  
**4822/00B**

BLANCO  
 BLANC  
 WHITE  
 BIANCO  
**OB**

Fe 80x40x2mm €/u

○

Fe 80x40x2mm €/u

○

Fe 60x30x3mm €/u

○

Fe 60x30x3mm €/u

○

Fe 80x40x2mm €/u

○

Fe 80x40x2mm €/u

○

**TIRANRES**

BLANCO  
 BLANC  
 WHITE  
 BIANCO  
**OB**

Fe €/u

○

○

○

○

○

○

○

○

○

○

○

Fe €/u

\*○

\*○

Fe €/u

\*○

\*○

Fe €/u

○

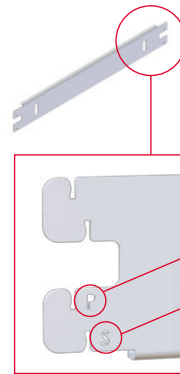

**TIRANTES DISTANCIADORES**  
 TIRANT-ESPACEMENT  
 ROD-SPACER  
 TIRANTE-DISTANZIATORE  
**4821/50B** EJE 512 MM  
**4821/60B** EJE 670 MM  
**4821/70B** EJE 730 MM  
**4821/80B** EJE 820 MM  
**4821/10B** EJE 1000 MM

**P: PARED (DIST. ENTRE COLUMNAS)**

**S: SUELO (DIST. ENTRE PIES)**

**MISMO TIRANTE PARA MONTANTES Y PIES**



**TIRANTE (ILUMINACIÓN)**  
 TIRANT-ESPACEMENT (ÉCLAIRAGE)  
 ROD-SPACER (LIGHTING)  
 TIRANTE (ILLUMINAZIONE)  
**\*4826/70B** EJE 730 MM  
**\*4826/80B** EJE 820 MM



**TIRANTE ENTRE PIES**  
 TIRANT-ESPACEMENT ENTRE LE PIED  
 ROD-SPACER BETWEEN FEET  
 TIRANTE FRA BASI MONTANTI  
**\*4827/50B** EJE 512 MM  
**\*4827/70B** EJE 650 MM



**TIRANTE TELESCÓPICO**  
 TIRANT TELESCOPIQUE  
 TELESCOPIC ROD-SPACER  
 TIRANTE TELESCOPICO  
**4840/00B**

**JUNTAS Y TAPAS**



**EMPALMADOR COLUMNA**  
 JOINT COLONNES  
 COLUMNS JOINT  
 GIUNZIONE PIANTANE  
**4825/00B**

Fe 90X50 mm €/u

○

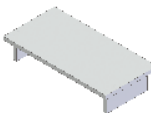

**TAPA COLUMNA**  
 BOUCHON  
 END-CAP UPRIGHT  
 COPRITESTA PIANTANA  
**4828/00B**

Fe 60X30 mm €/u

○



PORTA

RÓTULOS 5391/1..

\* MADERA NO INCLUIDA

COMPATIBLE  
KADÍ PRIMO



MATERIAL RÓTULO \*  
NO INCLUIDO

CARTELA CON CONECTOR  
PARA LETREROS CON  
ILUMINACIÓN  
5391/0..

SIN MONTAJE

Placard avec  
connecteur pour  
enseignes lumineuses.  
Placard with connector  
for illuminated signs.  
Cartello con connettore  
per insegne luminose.

1M máx.  
7 cm

Fe 72 mm medida útil

BLANCO BLANC WHITE BIANCO	NEGRO NOR BLACK NERO	COLOR COULEUR COLOR COLORE
OB	ON	OP

○	○	○	€/u
---	---	---	-----

ESTANTE

MADERA 5896/1..

COMPATIBLE  
KADÍ PRIMO



MADERA \*  
NO INCLUIDA

ESTANTE DE MADERA  
CON ILUMINACIÓN  
FRONTAL EMPOTRADA  
Y PERFIL DE ALUMINIO  
5896/1..

SIN MONTAJE

Étagère en bois avec  
éclairage zénithal monté sur  
l'étagère  
Wooden shelf with zenithal  
lighting mounted on the shelf  
Ripiano legno con  
illuminazione zenitale  
impotrata nel ripiano

1M máx.  
28 cm

PL. M. ALU. M. ALU. M. ALL. NAT.	BLANCO BLANC WHITE BIANCO	NEGRO NOR BLACK NERO	COLOR COULEUR COLOR COLORE
O1	OB	ON	OP

○	○	○	€/u
---	---	---	-----

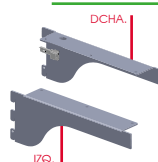

Kit 2 cartelas:  
DERECHA (con  
conector) +  
IZQUIERDA

KIT CARTELAS ESTANTE MADERA  
CON ILUMINACIÓN  
KIT SUPPORTS BOIS ILLUMINATION  
WOOD LIGHTING BRACKETS KIT  
KIT MENSOLE LEGNO  
ILLUMINAZIONE  
5381/0..

Fe	4890	€/u
	282 mm medida útil	

○	○	○
---	---	---



Medidas  
mecanizado  
16 x 6.8 mm

KIT PERFIL ALUMINIO CON  
DIFUSOR  
KIT PROFIL EN ALUMINIUM AVEC  
DIFFUSEUR  
KIT PROFILO IN ALLUMINIO CON  
DIFFUSORE  
3971/1..

Al	2M	18x9mm	€/m
----	----	--------	-----

○
---



126 diodos (20λ);  
cortable cada  
5.5 cm  
Cable, fil, wire,  
cavo: 40cm  
Ancho 8 mm  
flexible y con  
cinta adhesiva  
fleible and  
self-adhesive

LED CON MINI-CONECTOR 24V  
BANDE LED AVEC MINI-PLUG 24V  
LED STRIP WITH MINI-PLUG 24V  
STRIACIA LED CON MINI-PLUG  
24V  
4890/009

Pla	1 m	5000 K	€/u
		9,6 W 24V	

○
---

POSIBILIDAD DE COMBINAR CON  
EL SISTEMA "CUT-LINE"

SISTEMA DE PERFIL DE ALUMINIO CON LED INCORPORADO  
SE PUEDE ENCASTRAR A LA MADERA O AUTOADHESIVAR

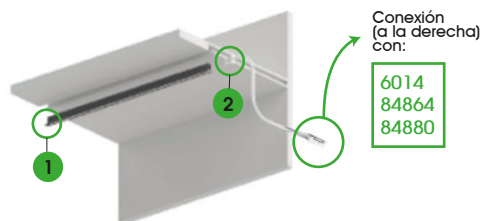

Conexión  
(a la derecha)  
con:  
6014  
84864  
84880

CORTE TOTALMENTE LIBRE, SIN LIMITES DE MEDIDAS

SE CORTA TODA LA ESTRUCTURA Y EL LED A LA MEDIDA DESEADA  
Y SE REMATA CON LOS TAPONES FINALES POR AMBOS LADOS

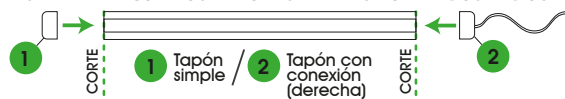

SISTEMA CUT-LINE

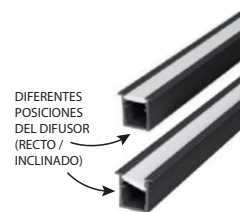

DIFERENTES  
POSICIONES  
DEL DIFUSOR  
(RECTO /  
INCLINADO)

PERFIL DE ALUMINIO CON LED  
INCORPORADO  
PROFILÉ EN ALUMINIUM AVEC LED  
INTÉGRÉE  
ALUMINIUM PROFILE WITH BUILT-IN LED  
PROFILO IN ALLUMINIO CON LED  
INTEGRATO

6025/301 4000K  
6026/301 5000K

SET CONECTOR + TAPA  
CABLE 40CM  
6030/041

GRAPAS  
6031/041

PL. M. ALU. M. ALU. M. ALL. NAT.
O1

Pla	3 m	€/u
	9,6W 24V	

○
○
○
○



### ESTANTE

#### VIDRIO 5895/1..

\* Recomendamos usar vidrios segurizados o laminados. (NO INCLUIDO)



**VIDRIO \* NO INCLUIDO**

ESTANTE DE VIDRIO CON ILUMINACIÓN FRONTAL  
**5895/1..**  
**MONTADO**

Étagère en verre avec éclairage avant  
Glass shelf with front lighting  
Ripiano vetro con illuminazione frontale

1M máx. 29 cm

PARA MADERA O VIDRIO

€/u

PL. M	BLANCO	NEGRO	COLOR
ALU. M	BLANC	NOR	COULEUR
ALL. M	WHITE	BLACK	COLOR
ALL. NAT	BIANCO	NERO	COLORE
01	0B	0N	0P

### ESTANTE

#### VIDRIO 5894/1..



**VIDRIO \* NO INCLUIDO**

ESTANTE DE VIDRIO CON ILUMINACIÓN CENITAL FRONTAL  
**5894/1..**  
**MONTADO**

Étagère en verre avec éclairage zenithal frontal  
Glass shelf with frontal zenithal lighting  
Ripiano di vetro con illuminazione zenitale frontale

1M máx. 27 cm

PARA MADERA O VIDRIO

€/u

PLÁSTICO	BLANCO	NEGRO	COLOR
PLASTIQUE	BLANC	NOR	COULEUR
PLASTIC	WHITE	BLACK	COLOR
PLASTICA	BIANCO	NERO	COLORE
09	0B	0N	0P

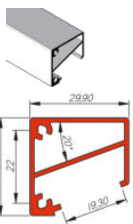

PERFIL ALUMINIO  
PROFIL EN ALUMINIUM  
ALUMINIUM PROFILE  
PROFILO DI ALUMINIO  
**4744/1..**

Al	5 m	30x30	€/m
Ⓞ 84602			

o o o o

Pla	2 m	Ⓞ 4744	€/m
-----	-----	--------	-----

PLÁSTICO	BLANCO	NEGRO	COLOR
PLASTIQUE	BLANC	NOR	COULEUR
PLASTIC	WHITE	BLACK	COLOR
PLASTICA	BIANCO	NERO	COLORE
09	0B	0N	0P

DIFUSOR PLÁSTICO MATE  
DIFFUSEUR EN PLASTIQUE MAT  
MATT PLASTIC DIFFUSOR  
DIFUSORE PLASTICO OPACO  
**84602/109**

o

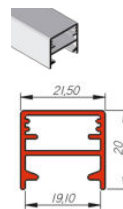

PERFIL ALUMINIO  
PROFIL EN ALUMINIUM  
ALUMINIUM PROFILE  
PROFILO DI ALUMINIO  
**4748/1..**

Al	6 m	21,5x20	€/m
Ⓞ 4893			

o o o

Pla	Ⓞ 4892 - 4894	€/m
-----	---------------	-----

PLÁSTICO	BLANCO	NEGRO	COLOR
PLASTIQUE	BLANC	NOR	COULEUR
PLASTIC	WHITE	BLACK	COLOR
PLASTICA	BIANCO	NERO	COLORE
09	0B	0N	0P

DIFUSOR PLÁSTICO MATE  
DIFFUSEUR EN PLASTIQUE MAT  
MATT PLASTIC DIFFUSOR  
DIFUSORE PLASTICO OPACO  
**4893/109**

o

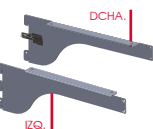

KIT CARTELAS ESTANTE VIDRIO CON ILUMINACIÓN  
KIT SUPPORTS VERRE ILLUMINATION  
GLASS LIGHTING BRACKETS KIT  
KIT MENSOLE VETRO ILLUMINAZIONE  
**3862/0..**

Fe	Ⓞ 4744-2556-4890	€/u
292 mm medida útil		

o o o

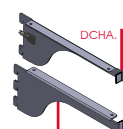

KIT CARTELAS ESTANTE VIDRIO CON ILUMINACIÓN  
KIT SUPPORTS VERRE ILLUMINATION  
GLASS LIGHTING BRACKETS KIT  
KIT MENSOLE VETRO ILLUMINAZIONE  
**5385/0..**

Fe	Ⓞ 4744-2556-4890	€/u
270 mm medida útil		

o o o

Cada cartela tiene 2 taladros para usar 1 perfil 4744

Kit 2 cartelas: DERECHA (con conexión) + IZQUIERDA



LED CON MINI-CONECTOR 24V  
BANDE LED AVEC MINI-PLUG 24V  
LED STRIP WITH MINI-PLUG 24V  
STRACIA LED CON MINI-PLUG 24V  
**4890/109**

Pla	1 m	5000 K	€/u
Ⓞ CRI>90 Ⓞ 9,6 W 24V			

o

126 diodos (20λ); cortable cada 5,5 cm  
Cable, fil, wire, cavo: 26cm  
Ancho 8mm  
flexible y con cinta adhesiva  
fleible and self-adhesive

LED CON MINI-CONECTOR 24V  
BANDE LED AVEC MINI-PLUG 24V  
LED STRIP WITH MINI-PLUG 24V  
STRACIA LED CON MINI-PLUG 24V  
**4890/109**

Pla	1 m	5000 K	€/u
Ⓞ CRI>90 Ⓞ 9,6 W 24V			

o



VENTOSA TRANSPARENTE  
VENTOUSE  
SUCITON  
VENTOSA  
**2556/009**

Pla	∅14 mm	Ⓞ 4880	€/u
-----	--------	--------	-----

o



VENTOSA TRANSPARENTE  
VENTOUSE  
SUCITON  
VENTOSA  
**2556/009**

Pla	∅14 mm	Ⓞ 4880	€/u
-----	--------	--------	-----

o



**\* ESTANTE**

**VIDRIO 5890/1..**

\* Recomendamos usar vidrios segurizados o laminados. (NO INCLUIDO)



VIDRIO \*  
NO INCLUIDO

ESTANTE DE VIDRIO  
RETROILUMINADO

\*5890/1..

**MONTADO**

Étagère en verre extra claire retro-éclairé  
Blacklit optical glass shelf  
Ripiano vetro extralight retroilluminato

1M máx.  
30 cm

PL. M	BLANCO	NEGRO	COLOR
ALU. M	BLANC	NOIR	COULEUR
ALL. NAT	WHITE	BLACK	COLOR
	BANCO	NERO	COLORE
01	0B	0N	0P

\*o \*o \*o

€/u

**\* ESTANTE**

**VIDRIO 5891/1..**



VIDRIO \*  
NO INCLUIDO

ESTANTE DE VIDRIO  
CON ILUMINACIÓN  
FRONTAL

\*5891/1..

**MONTADO**

Étagère en verre avec éclairage zénithal frontal  
Glass shelf with frontal zenithal lighting  
Ripiano di vetro con illuminazione zenitale frontale

1M máx.  
30 cm

PL. M	BLANCO	NEGRO	COLOR
ALU. M	BLANC	NOIR	COULEUR
ALL. NAT	WHITE	BLACK	COLOR
	BANCO	NERO	COLORE
01	0B	0N	0P

\*o \*o \*o

€/u



Junta goma incluida  
Joint en caoutchouc  
Inclus rubber gasket  
Includet glijntje di  
gomma inclusa

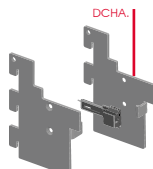

Con perfil 362  
Kit 2 correas:  
DERECHA (con  
conector) +  
IZQUIERDA



126 diodos (20λ);  
cortable cada  
5,5 cm  
Cable, fil, wire,  
cavo: 26cm  
Ancho 8mm

flexible y con  
cinta adhesiva  
flexible and  
self-adhesive

PERFIL ALUMINIO  
PROFIL LAME D'ALUMINIUM  
ALUMINIUM SLATWALL  
PROFILE  
PROFILO DOGATO  
ALLUMINIO

\*362/1..

Al	5 m	6-8mm	€/m
⊙	361/109		

\*o \*o \*o \*o

KIT CARTELAS ESTANTE  
VIDRIO CON  
ILUMINACIÓN  
KIT SUPPORTS VERRE  
ILUMINATION  
GLASS LIGHTING  
BRACKETS KIT  
KIT MENSOLE VETRO  
ILLUMINAZIONE

\*5384/0..

Fe	362 - 4890	€/u
⊙	68,5mm medida útil	

\*o \*o \*o

LED CON  
MINI-CONECTOR 24V  
BANDE LED AVEC  
MINI-PLUG 24V  
LED STRIP WITH  
MINI-PLUG 24V  
STRIACIA LED CON  
MINI-PLUG 24V

4890/109

Pla	1 m	5000 K	€/u
⊙	CRI>90	9.6 W 24V	

o

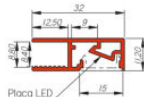

PERFIL ALUMINIO  
PROFIL EN ALUMINIUM  
ALUMINIUM PROFILE  
PROFILO DI ALLUMINIO

4892/1..

Al	5 m	32x11,2	€/m
⊙	4893 - 4894		

o o o o

DIFUSOR DE PLÁSTICO MATE  
DIFFUSEUR EN PLASTIQUE MAT  
MATT PLASTIC DIFUSOR  
DIFUSORE PLASTICO OPACO

4893/109

Pla	4892 - 4894	€/m
⊙	2 m	

o

KIT TAPAS FINALES LATERALES  
COUVERTURE LATÉRALE FINALE  
LATERAL END CAP  
COPERTURA LATERALE FINALE

4894/0..

Pla	32x11,2 mm	€/u
⊙	4892	

o o

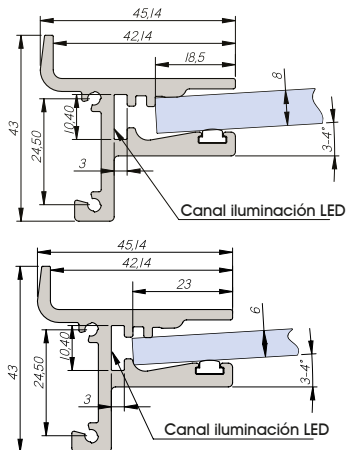

**(ES) • MÁXIMA  
MEDIDA ESTANTE  
RECOMENDADA:  
100 X 30 CM.**

**(FR) • Maximum  
recommended  
shelf size: 100 x  
30 cm.**

**(IT) • Dimensione  
massima  
raccomandata  
dello scaffale:  
100 x 30 cm.**

**(EN) • Taille  
maximale de  
l'étagère  
recommandée:  
100 x 30 cm.**



## PENDERIE 5897/1..

\* MADERA NO INCLUIDA

KIT compuesto por:  
- Cartelas Ref.5382  
-Tubo rectangular Ref.4900/12B  
-LED de 1m



**VIDRIO / MADERA NO INCLUIDO**

ESTANTE + BARRA DE CUELQUE LATERAL CON ILUMINACIÓN Y PROTECCIÓN PLÁSTICA SUPERIOR 5897/1..

### MONTADO

Tablette + barre de suspension latérale avec éclairage  
Shelf + side hanging bar with lighting  
Mensola + barra appendiabiti laterale con illuminazione

1M máx. 29cm

PLÁSTICO PLASTIQUE PLASTICA	BLANCO BLANC WHITE	NEGRO NOIR BLACK	COLOR COULEUR COLOR COLORE
09	0B	0N	0P

## BARRA DE CUELQUE LATERAL 5898/1..

KIT compuesto por:  
- Cartelas Ref.5383  
-Tubo rectangular Ref.4900/12B  
-LED de 1m



BARRA DE CUELQUE LATERAL CON ILUMINACIÓN Y PROTECCIÓN PLÁSTICA SUPERIOR 5898/1..

### MONTADO

Barre de suspension latérale avec éclairage  
Side hanger bar with lighting  
Barra appendiabiti laterale con illuminazione

1M máx. 29cm

PL. M ALL. M ALL. M ALL. NAT	BLANCO BLANC WHITE	NEGRO NOIR BLACK	COLOR COULEUR COLOR COLORE
01	0B	0N	0P

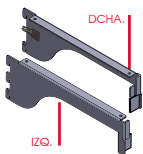

Kit 2 cartelas: DERECHA (con conector) + IZQUIERDA

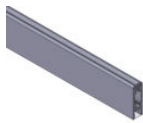

LED no incluido. LED recomendado de 5mm de ancho. Incluye perfil de plástico superior y difusor interior.

**KIT CARTELAS BARRA ACCESORIOS**  
KIT SUPPORT BARRE ACCESSOIRES  
KIT BRACKET FOR ACCESSORIES ROD  
KIT MENSOLA TUBO PORTA-ACCESSORI 5382/00.

Fe	4900	€/u
290 mm medida útil		

Al	1 m	30x10	€/u
4901			

**TUBO RECTANGULAR PARA ILUMINACIÓN 30X10MM CON PLETINA DE REFUERZO**  
KIT TUBE RECTANGULAIRE POUR ECLAIRAGE 30X10MM AVEC PLAQUE DE RENFORT  
KIT RECTANGULAR TUBE FOR LIGHTING 30X10MM WITH REINFORCING PLATE  
KIT TUBO RETTANGOLARE PER ILLUMINAZIONE 30X10MM CON PIASTRA DI RINFORZO 4900/12.

**CON ALMA DE ACERO INOX**

**CARGA LIGERA**  
max. 30KG

182 diodos (20λ); cortable cada 3.8 cm  
Cable, fil, wire, cavo: 40cm  
Ancho 5mm  
flexible y con cinta adhesiva flexible and self-adhesive

**LED CON MINI-CONECTOR 24V**  
BANDE LED AVEC MINI-PLUG 24V  
LED STRIP WITH MINI-PLUG 24V  
STRACIA LED CON MINI-PLUG 24V 4910/109

Pla	1 m	5000 K	€/u
CRI>90 15,3W 24V			

PLÁSTICO PLASTIQUE PLASTICA

09

Pla	14 mm	4880	€/u
-----	-------	------	-----

**VENTOSA TRANSPARENTE**  
VENTOUSE  
SUCITON  
VENTOSA 2556/009

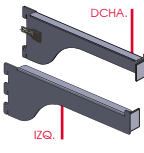

Kit 2 cartelas: DERECHA (con conector) + IZQUIERDA

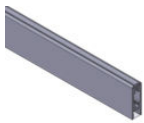

LED no incluido. LED recomendado de 5mm de ancho. Incluye perfil de plástico superior y difusor interior.

**KIT CARTELAS BARRA ACCESORIOS**  
KIT SUPPORT BARRE ACCESSOIRES  
KIT BRACKET FOR ACCESSORIES ROD  
KIT MENSOLA TUBO PORTA-ACCESSORI 5383/00.

Fe	4900	€/u
290 mm medida útil		

Al	1 m	30x10	€/u
4901			

**TUBO RECTANGULAR PARA ILUMINACIÓN 30X10MM CON PLETINA DE REFUERZO**  
KIT TUBE RECTANGULAIRE POUR ECLAIRAGE 30X10MM AVEC PLAQUE DE RENFORT  
KIT RECTANGULAR TUBE FOR LIGHTING 30X10MM WITH REINFORCING PLATE  
KIT TUBO RETTANGOLARE PER ILLUMINAZIONE 30X10MM CON PIASTRA DI RINFORZO 4900/12.

**CON ALMA DE ACERO INOX**

**CARGA LIGERA**  
max. 30KG

182 diodos (20λ); cortable cada 3.8 cm  
Cable, fil, wire, cavo: 40cm  
Ancho 5mm  
flexible y con cinta adhesiva flexible and self-adhesive

**LED CON MINI-CONECTOR 24V**  
BANDE LED AVEC MINI-PLUG 24V  
LED STRIP WITH MINI-PLUG 24V  
STRACIA LED CON MINI-PLUG 24V 4910/109

Pla	1 m	5000 K	€/u
CRI>90 15,3W 24V			

PLÁSTICO PLASTIQUE PLASTICA

09

## SISTEMA CUT-LINE

DIFFERENTES POSICIONES DEL DIFUSOR (RECTO / INCLINADO)



**PERFIL DE ALUMINIO CON LED INCORPORADO**  
PROFILÉ EN ALUMINIUM AVEC LED INTÉGRÉE  
ALUMINIUM PROFILE WITH BUILT-IN LED  
PROFILO IN ALLUMINIO CON LED INTEGRATO

4000K 6025/301  
5000K 6026/301

**SET CONECTOR + TAPA CABLE 40CM**  
6030/041

**GRAPAS**  
6031/041

PL. M ALL. M ALL. M ALL. NAT	01
------------------------------	----

Pla	3 m	€/u
CRI>90 9,6W 24V		

## SISTEMA DE PERFIL DE ALUMINIO CON LED INCORPORADO

SE PUEDE ENCASTRAR A LA MADERA O AUTOADHESIVAR

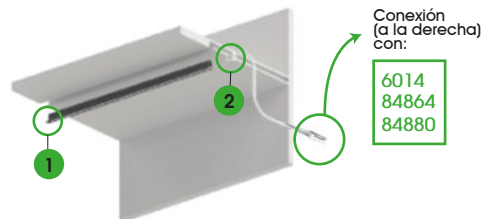

**CORTE TOTALMENTE LIBRE, SIN LIMITES DE MEDIDAS**  
SE CORTA TODA LA ESTRUCTURA Y EL LED A LA MEDIDA DESEADA Y SE REMATA CON LOS TAPONES FINALES POR AMBOS LADOS





**BARRA ACCES. FR.**

**5901/1..**

PL. M ALU. M ALU. M ALL. NAT	BLANCO BLANC WHITE BIANCO	NEGRO NOIR BLACK NERO	COLOR COULEUR COLOR COLORE
01	0B	0N	0P

KIT compuesto por:  
- Cartelas Ref.5380  
-Tubo rectangular  
Ref.4900/12B  
-LED de 1m

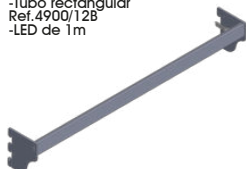

BARRA DE CUELGUE PARA  
ACCESORIOS FRONTALES  
CON ILUMINACIÓN Y  
PROTECCIÓN PLÁSTICA  
SUPERIOR

**5901/1..**

**MONTADO**

Barre de suspension pour  
accessoires avant avec  
éclairage  
Hanger bar for front  
accessories with lighting  
Barra appendibili per  
accessori frontali con  
illuminazione

1M máx.  
7  
cm

€/u

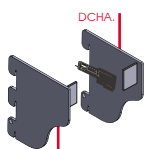

Kit de 2  
cartelas:  
DERECHA (con  
conector) +  
IZQUIERDA

**KIT CARTELAS BARRA  
ACCESORIOS**  
KIT SUPPORT BARRE  
ACCESSOIRES  
KIT BRACKET FOR  
ACCESSORIES ROD  
KIT MENSOLA TUBO  
PORTA-ACCESSORI

**5380/0..**

Fe	⊙ 4900	€/u
71 mm medida útil		

o o o



LED no incluido.  
LED  
recomendado de  
5mm de ancho.  
Incluye perfil de  
plástico superior y  
difusor interior.

**TUBO RECTANGULAR PARA  
ILUMINACIÓN 30X10MM CON  
PLETINA DE REFUERZO**  
KIT TUBE RECTANGULAIRE POUR  
ECLAIRAGE 30X10MM AVEC  
PLAQUE DE RENFORT  
KIT RECTANGULAR TUBE FOR  
LIGHTING 30X10MM WITH  
REINFORCING PLATE  
KIT TUBO RETTANGOLARE PER  
ILLUMINAZIONE 30X10MM CON  
PIASTRA DI RINFORZO

**4900/12.**

**CON ALMA DE  
ACERO INOX**

**CARGA LIGERA**

Al	⊔ 1 m	€/u
30x10	⊙ 4901	

o o o



182 diodos (20λ);  
cortable cada  
3.8 cm  
Cable, fil. wire,  
cavo: 45 mm  
Ancho 5mm

flexible y con  
cinta adhesiva  
fleible and  
self-adhesive

**LED CON  
MINI-CONECTOR 24V**  
BANDE LED AVEC  
MINI-PLUG 24V  
LED STRIP WITH  
MINI-PLUG 24V  
STRISCIA LED CON  
MINI-PLUG 24V

**4901/109**

Pla	⊔ 1 m	⚡ 5000 K	€/u
⊙ CRI > 90		⊖ 15,3W 24V	

PLÁSTICO  
PLASTIQUE  
PLASTIC  
PLASTICA

09

o

**EJEMPLO DE APLICACIÓN**

Barras de  
accesorios con  
cuelgue frontal.



**NO APTO PARA  
PERROQUET  
SOLO GANCHO**

**CARGA LIGERA**

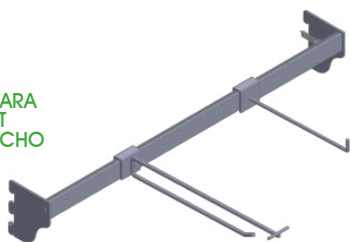



KADÍ PRIMO - ELEKTRIC





INSTAL  
ILUMINACIÓN



KADÍ ELEKTRIC  
PRIMO C.227



ESCANEA ESTE QR  
PARA VER TODAS  
LAS IMÁGENES DEL  
SISTEMA PHARMA



KADÍ  
PRIMO  
ELEKTRIC

Ejemplos orientativos  
de distintas posibilidades,  
distribuciones y  
aplicaciones



EXPLOSIONADO GENERAL

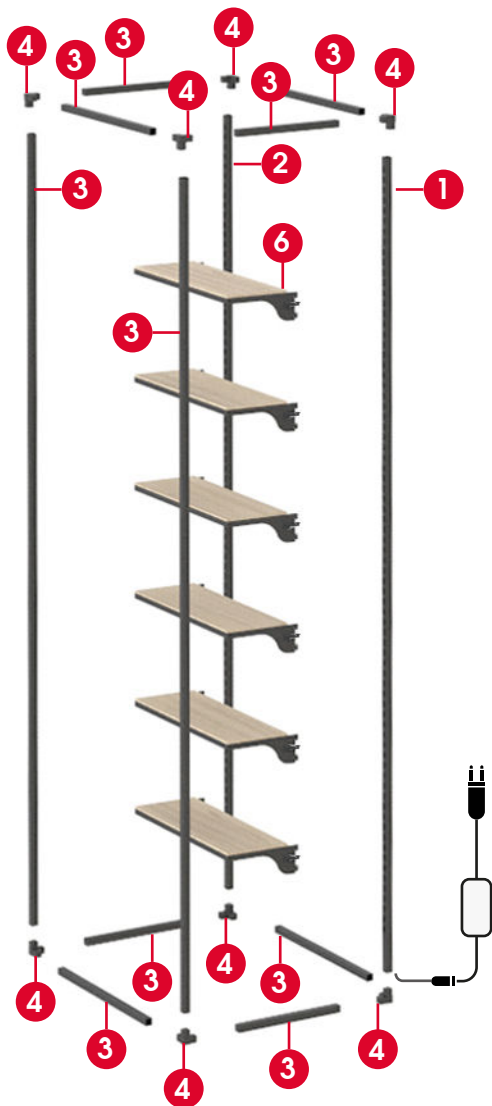

MONTAJE EN SERIE

Colocar las cremalleras **ELECTRIFICADAS** EN EL LADO DERECHO de cada panel

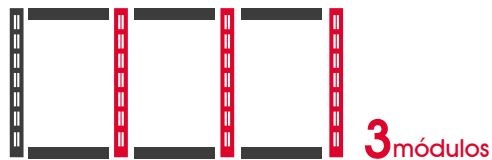

REF: 3960  
+ 3961 (CARRIL ELEKTRIC)

Tubos electrificados

Solo los orificios izquierdos (representados en rojo) están electrificados.

REF: 3960

Tubos sin carril eléctrico

**1** Tubo primo electrificado - 1 cara  
REF: 3960 +3961



**2** Tubo primo troquelado 25x25  
REF: 3960



**3** Tubo sin troquelar 25x25  
REF: 3910



**4** Nudos



NUEVOS NUDOS

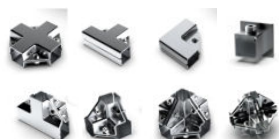

**5** Tapones



**6** Accesorios

Personalizable:  
- Estantes  
- Barras  
- Perroquets



## MONTAJE CON EL SISTEMA -> MAGNETIC

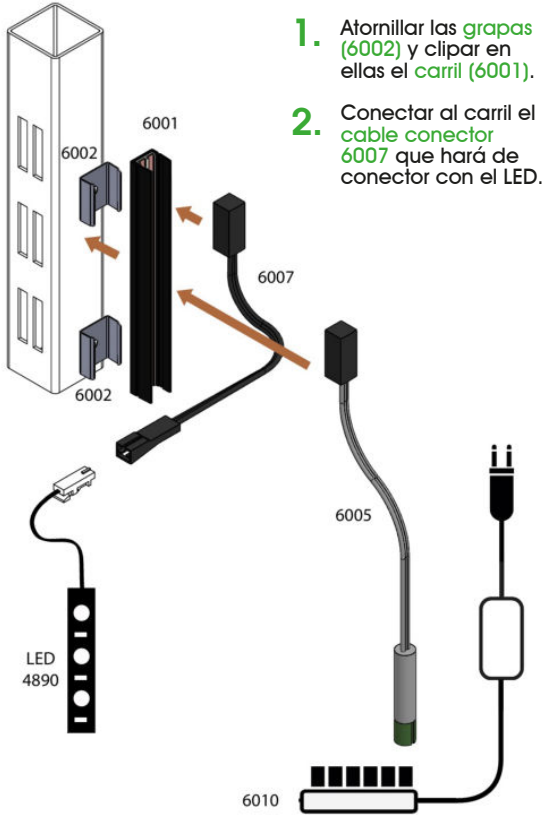

1. Atornillar las grapas (6002) y clipar en ellas el carril (6001).
2. Conectar al carril el cable conector 6007 que hará de conector con el LED.

3. Conectar al carril el cable conector 6005 que hará de conector con el driver (6010).

\* Los cables conectores se fijan con imán automáticamente al acercar las boquillas imantadas al carril (6001).

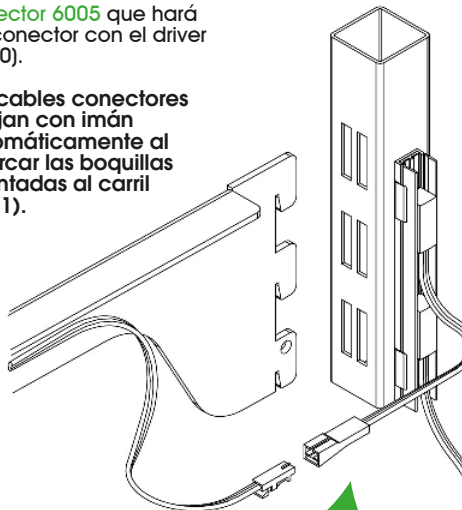

Sistema MAGNETIC colocado en una estructura del sistema PRIMO y con los cables conectores imantados.

## MONTAJE CON EL SISTEMA -> EASY

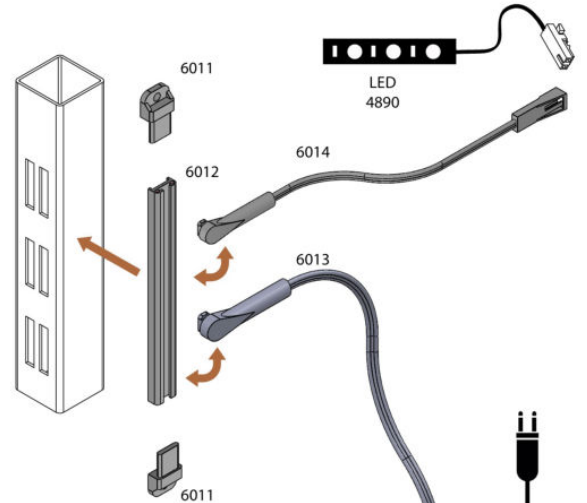

1. Colocar los tapones finales (6011) en los extremos del carril (6012) y colocarlo mediante cinta adhesiva. Atornillar los tapones.
2. Conectar al carril el cable conector 6014 que hará de conector con el LED.
3. Conectar al carril el cable conector 6013 que hará de conector con el driver (6010).

\* Los cables conectores entran con la boquilla en perpendicular y al realizar un cuarto de giro (quedando alineados con el carril) quedan totalmente fijados.

Sistema EASY colocado en una estructura del sistema PRIMO y con los cables conectores fijados.

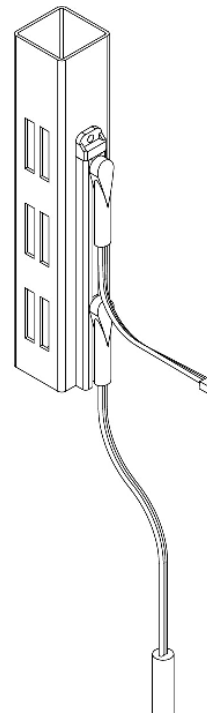

LOS CABLES CONECTORES DEBEN MANTENER TODOS LA MISMA DIRECCIÓN PARA MANTENER LA POLARIDAD





TOPE, GRAPAS Y CABLE

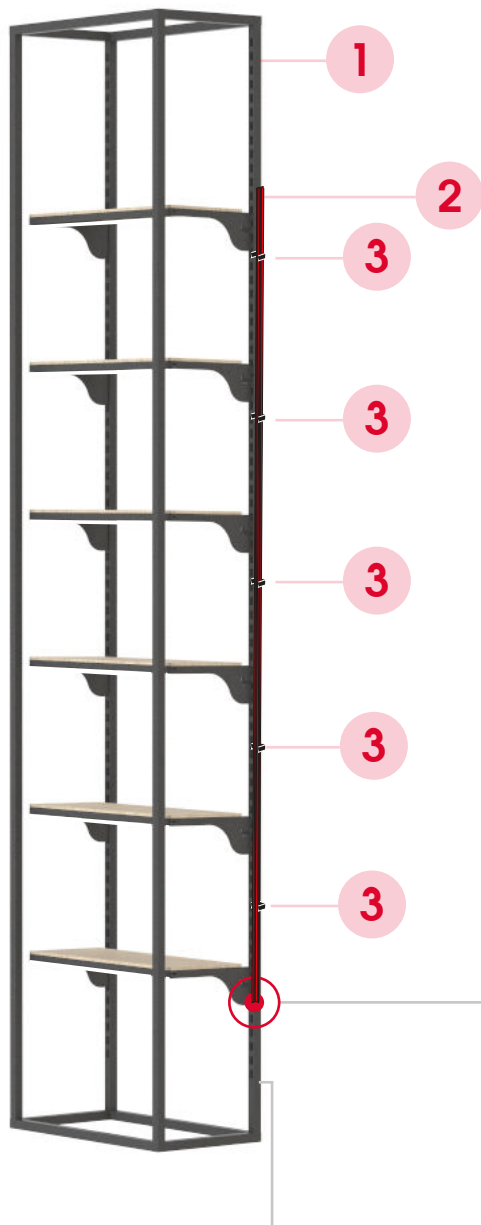

3 Grapas de plástico



- Las grapas deben ir repartidas de manera equitativa
- Colocar entre 4 y 8 grapas dependiendo de la medida.
- Tanto el tubo Primo ( 1 ) como el carril electrificado ( 2 ) se pueden adaptar a cualquier medida. Posibilidad de cortar.

INICIO DEL CARRIL ELECTRIFICADO

4 Tope inferior

El tope inferior puede colocarse en cualquier orificio de la cremallera

Crea el inicio del carril electrificado

El carril queda apoyado al tope

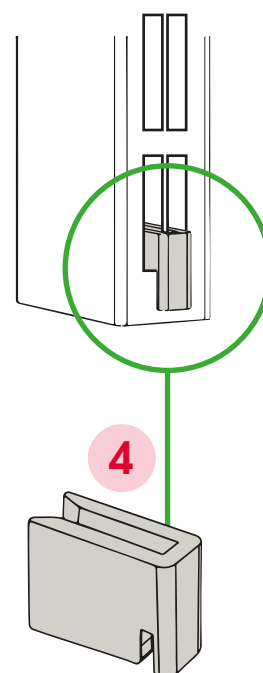

Crear un corte para la salida del cable eléctrico

Tener en cuenta el tipo de unión o nudo que se utilizará para que el orificio no interseccione con la pieza interior

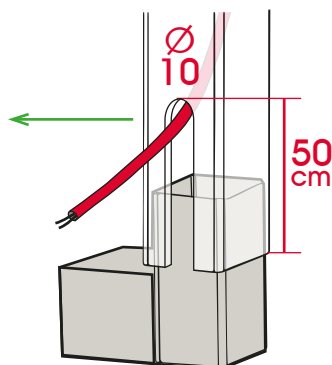



## CARRIL ELECTRICO

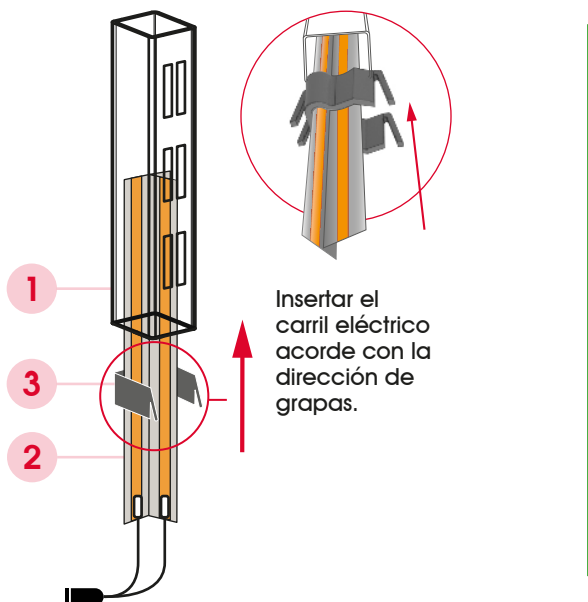

- 1 **Tubo Primo 25x25x1,2** ALTURA 2938
- 2 **Carril eléctrico**
- 3 **Grapas de plástico**
- 4 **Tope inferior**

## COLOCACIÓN DEL CONECTOR

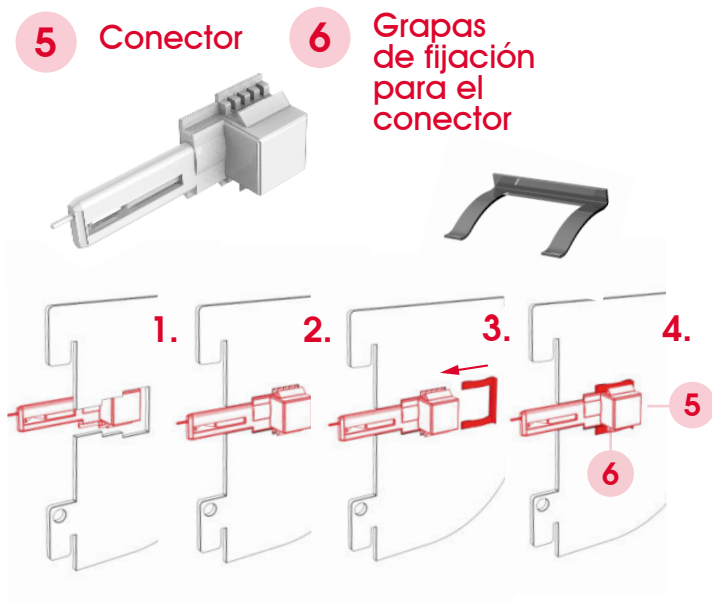

## CARRIL-CABLE

• El carril electrificado lleva soldado el cable de conexión en la parte inferior. En el caso de precindir de este conector, prestar atención a la polaridad de los cables para el correcto funcionamiento de la nueva conexión.

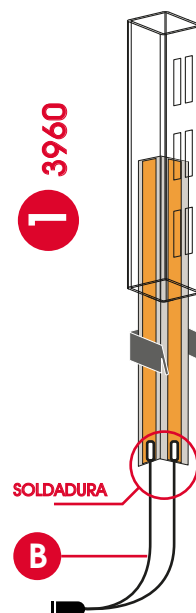



ACCESORIOS PRIMO



Vidrio



Madera



Diferentes materiales y acabados

ESTANTES

CARGA LIGERA



5890..



NUEVO

5891..



NUEVO

CARGA MEDIA



CARGA ALTA



5894..



NUEVO

5896..



NUEVO

5895..



NUEVO

BARRAS

CARGA LIGERA



CARGA MEDIA



5898..



NUEVO

5901..



NUEVO

5897..



NUEVO

PORTA ROTULOS

CARGA LIGERA



5391



NUEVO



## TABLA DE PESOS

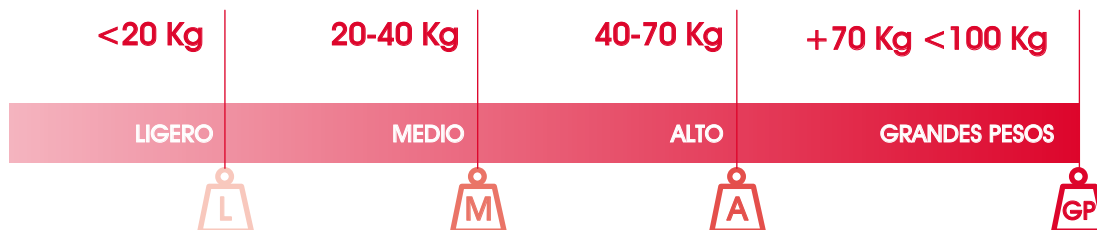

## COMPORTAMIENTO DE PESOS

● Puntos conflictivos de carga



La inclinación puede variar dependiendo del peso y la flexibilidad del aluminio.

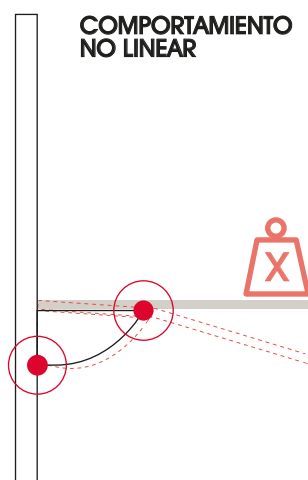
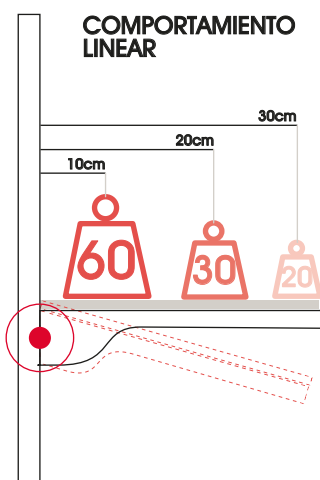

## PLUG & PLAY

AL  
ENCAJAR  
SE ENCIENDE 

Con el sistema PLUG & PLAY el montaje de los módulos de carga resulta fácil, rápido y muy práctico, ya que solo encajando las cartelas a las cremalleras, el circuito eléctrico queda totalmente conectado y el LED encendido.

- FÁCIL
- RÁPIDO
- PRÁCTICO





### COMPONENTES POR PIEZA/METRO

#### CREMALLERAS

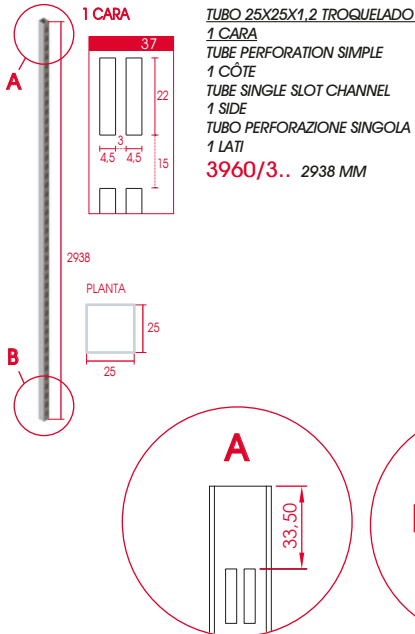

BLANCO BLANC WHITE BIANCO	NEGRO NOIR BLACK NERO	COLOR COULEUR COLOR COLORE
OB	ON	OP
Fe	25x25x1,2mm	€/u

○ ○ ○

#### DRIVER



DRIVER 100W, 24V / CONECTOR HEMBRA CONDUCTEUR 100W, 24V / CONNECTEUR FEMELLE DRIVER 100W, 24V / FEMALE CONNECTOR DRIVER 100W, 24V / CONNETTORE FEMMINA	6 SALIDAS	6010/009
Placa	24V 100W	€/u
	15cm	
CABLE CON MINI-CONECTORES 230V CABLE + MINI PLUG - 230V CABLE + MINI PLUG - 230V CAVO + MINI PLUG - 230V <td>6015/00B</td> <td>○</td>	6015/00B	○
Placa	3m	€/u
	230V	2,5 A

PLÁSTICO  
PLASTIQUE  
PLASTIC  
PLASTICA  
09

CONECTOR DIVER 6 VÍAS 20CM CONNECTEUR PLONGEUR 6 VOIES 20CM 6-WAY DIVER CONNECTOR 20CM CONNETTORE SUBACQUEO A 6 VIE 20 CM	6021/009	
Placa	3m	€/u
	230V	2,5 A
CABLE ALARGO MACHO-HEMBRA 3M CÂBLE D'EXTENSION MÂLE-FEMELLE DE 3 M 3M MALE-FEMALE EXTENSION CABLE CAVO DI PROLUNGA MASCHIO-FEMMINA 3M	6022/00B	
Placa	€/u	
	230V	2,5 A
	3m	2,5 A

CON CONECTOR NUEVO ○

#### CABLES



CABLE MINI PLUG - ABIERTO 24V CABLE MINI PLUG - OVERTE 24V CABLE MINI PLUG - OPEN ENDED 24V CAVO MINI PLUG - APERTO 24V	4888/009	
Placa	400m	€/u
	24V	2,5 A

#### EASY



Para instalaciones móviles permite quitar y poner MAGNÉTICO

CARRIL ELECTRIFICADO RAIL ÉLECTRIFIÉ ELECTRIFIED RAIL BINARIO ELETRIFICATO MAGNETICO	6001/20N	
Placa	2m	€/u

CINTA MAGNÉTICA ADHESIVA RUBAN MAGNÉTIQUE ADHÉSIF ADHESIVE MAGNETIC TAPE NASTRO MAGNETICO ADESIVO	6012/000 50M 6012/100 1M
€/u	○
€/m	○

CINTA ADHESIVA DOBLE CARA RUBAN MAGNÉTIQUE ADHÉSIF ADHESIVE MAGNETIC TAPE NASTRO MAGNETICO ADESIVO	6012/009 66M
€/u	○

CONECTOR CARRIL-DRIVER/ CONECTOR SEGURIDAD ALUSYSTEM CONNECTEUR RAIL-DRIVER / CONNECTEUR SECURITÉ DU ALUSYSTEM CONNECTOR RAIL-DRIVER / CONNECTOR ALUSYSTEM SECURITY CONNETTORE RAIL-DRIVER / CONNETTORE LA SICUREZZA ALUSYSTEM	6013/0..	
Placa	24V	€/u
	1M	

CONECTOR CARRIL-LED / HEMBRA CONNECTEUR RAIL-LED / FEMELLE RAIL-LED CONNECTOR / FEMALE CONNETTORE RAIL-LED / FEMMINA	6014/0..	
Placa	24V	€/u
	10cm	

TAPÓN FINAL BOUCHON D'EXTRÉMITÉ END CAP TAPPO TERMINALE	6011/0.. SET 2 U.
€/u	○
	○

BLANCO  
BLANC  
WHITE  
BIANCO

NEGRO  
NOIR  
BLACK  
NERO

OB ON

PLÁSTICO  
PLASTIQUE  
PLASTIC  
PLASTICA  
09

#### MAGNETIC LED

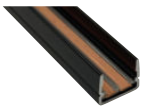

MAGNÉTICO



CARRIL ELECTRIFICADO  
MAGNÉTICO  
RAIL ÉLECTRIFIÉ MAGNÉTIQUE  
MAGNETIC ELECTRIFIED RAIL  
BINARIO ELETRIFICATO  
MAGNETICO

6001/20N ○

CLIP PARA FIJACIÓN  
CLIP DE FIXATION  
FIXING CLIP  
CLIP DI FISSAGGIO

6002/028 ○



MAGNÉTICO

CONECTOR MAGNÉTICO  
CARRIL-DRIVER  
CONNECTEUR MAGNÉTIQUE  
RAIL-DRIVER  
MAGNETIC CONNECTOR  
RAIL-DRIVER  
CONNETTORE MAGNETICO  
RAIL-DRIVER

6005/00N ○



MAGNÉTICO

CONECTOR MAGNÉTICO  
CARRIL-CONECTOR CARTELAS KADI  
CONNECTEUR MAGNÉTIQUE  
RAIL-CONNECTEUR SUPPORT KADI  
MAGNETIC CONNECTOR  
RAIL-CONNECTOR KADI BRACKET  
CONNETTORE MAGNETICO BINARIO  
- CONNETTORE MENSOLA KADI

6006/00N ○



MAGNÉTICO

CONECTOR MAGNÉTICO  
CARRIL-LED UNIVERSAL  
CONNECTEUR MAGNÉTIQUE  
RAIL-LED UNIVERSAL  
MAGNETIC CONNECTOR  
RAIL-UNIVERSAL LED  
CONNETTORE MAGNETICO  
BINARIO-UNIVERSALE LED

6007/00N ○

INOX SAT INOX SAT S.S.S.	NEGRO NOIR BLACK NERO	
28	ON	
Placa	2m	€/u

⊕ 6001-6012 €/u

Placa	2A	€/u
	150cm	

Placa	2A	€/u
	40cm	

Placa	2A	€/u
	40cm	



COMPONENTES POR PIEZA/METRO

KITS CARRIL ELECTRIFICADO

PL. M  
ALU. M  
ALL. NAT  
01

KIT 1 CARA



**KIT PERFIL DE ALUMINIO  
ELECTRIFICADO A UNA CARA  
CON GRAPAS DE PLÁSTICO**  
KIT PROFILÉ ALUMINIUM  
ÉLECTRIFIÉ D'UN CÔTÉ AVEC DES  
AGRAFES EN PLASTIQUE  
KIT ALUMINIUM PROFILE  
ELECTRIFIED ON ONE SIDE WITH  
PLASTIC STAPLES  
KIT PROFILO IN ALLUMINIO  
ELETRIFICATO SU UN LATO CON  
GRAFFE IN PLASTICA

**3961/241** 240 CM  
**3961/181** 180 CM  
**3961/121** 120 CM

Al 22x13 mm €/u

\*o  
\*o  
\*o

Nº COMPONENTES/MEDIDA

MEDIDA	240 cm	180 cm	120 cm
<b>Grapas</b>	X8 uds	X6 uds	X4 uds
<b>Carril electrificado</b>	1 carril de 240	1 carril de 180	1 carril de 120
<b>Tope inferior</b>	X1 ud	X1 ud	X1 ud

SISTEMA DE FÁCIL CONEXIÓN - PLUG & PLAY

KIT CARRIL ELECTRIFICADO

PL. M  
ALU. M  
ALL. NAT  
01

KIT 1 CARA



Longitud cable 1m.

Gesls® GST0812G

**KIT PERFIL DE ALUMINIO  
ELECTRIFICADO A UNA CARA  
CON GRAPAS DE PLÁSTICO**  
KIT PROFILÉ ALUMINIUM  
ÉLECTRIFIÉ D'UN CÔTÉ AVEC DES  
AGRAFES EN PLASTIQUE  
KIT ALUMINIUM PROFILE  
ELECTRIFIED ON ONE SIDE WITH  
PLASTIC STAPLES  
KIT PROFILO IN ALLUMINIO  
ELETRIFICATO SU UN LATO CON  
GRAFFE IN PLASTICA

**3961/241** 240 CM  
**3961/181** 180 CM  
**3961/121** 120 CM

Al 22x13 mm €/u

\*o  
\*o  
\*o

Nº COMPONENTES/MEDIDA

MEDIDA	240 cm	180 cm	120 cm
<b>Grapas</b>	X8 uds	X6 uds	X4 uds
<b>Carril electrificado</b>	1 carril de 240	1 carril de 180	1 carril de 120
<b>Tope inferior</b>	X1 ud	X1 ud	X1 ud
<b>Conector Gesls</b>	X1 ud	X1 ud	X1 ud

CONECTORES COMPATIBLE KADÍ PHARMA

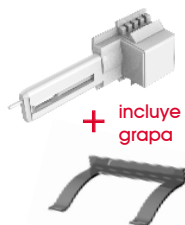

+ incluye grapa

**CONECTOR PLUG & PLAY,  
BLANCO / NEGRO**  
CONNECTEUR PLUG & PLAY,  
BLANC / NOIR  
CONNECTOR PLUG & PLAY,  
WHITE / BLACK  
CONNETTORE PLUG & PLAY,  
BIANCO / NERO

**84864/OOB**  
**84864/OON**

PLÁSTICO  
PLASTIQUE  
PLASTIC  
PLASTICA  
09

Pla 1 m  
CE IP20

24V max.3A €/u

\*o  
\*o

Cualquier  
manipulación invalida  
la garantía del  
fabricante





### NUDOS PRESIÓN



**NUDO 3 VIAS**  
JOINT À 3 VOIES  
3 WAY JOINT  
GIUNTO 3 VIE  
**3900/0..**

**NUDO 3 VIAS + ROSCAM10**  
JOINT À 3 VOIES + TROU M10  
3 WAY JOINT + M10 HOLE  
GIUNTO 3 VIE + FORO M10  
**3901/0..**

**NUDO 4 VIAS**  
JOINT À 4 VOIES  
4 WAY JOINT  
GIUNTO 4 VIE  
**3902/0..**

**NUDO 4 VIAS + ROSCAM10**  
JOINT À 4 VOIES + TROU M10  
4 WAY JOINT + M10 HOLE  
GIUNTO 4 VIE + FORO M10  
**3903/0..**

**NUDO 5 VIAS**  
JOINT À 5 VOIES  
5 WAY JOINT  
GIUNTO 5 VIE  
**3904/0..**

**NUDO 3 VIAS "T"**  
JOINT À 3 VOIES "T"  
"T" 3 WAY JOINT  
GIUNTO 3 VIE "T"  
**3907/0..**

**NUDO 2 VIAS**  
JOINT À 2 VOIES  
2 WAY JOINT  
GIUNTO 2 VIE  
**3905/0..**

CR. BILLO CH. FOU BR. CHR CR. ILLC.	BLANCO BLANC WHITE BIANCO	NEGRO NOR BLACK NERO	COLOR COULEUR COLOR COLORE			
32	OB	ON	OP			
Zn	25x25 mm			€/u		
		o	o			
Zn	25x25mm			€/u		
		o	o			
Zn	25x25 mm			€/u		
		o	o			
Zn	25x25mm M10			€/u		
		o	o			
Zn	25x25mm			€/u		
		o	o			
Zn	20x20mm			€/u		
		o	o			
Zn	25x25mm			€/u		
		o	o			

### NUDOS BRIDA



**NUDO 3 VIAS**  
JOINT À 3 VOIES  
3 WAY JOINT  
GIUNTO 3 VIE  
**3980/0..**

**NUDO 4 VIAS**  
JOINT À 4 VOIES  
4 WAY JOINT  
GIUNTO 4 VIE  
**3982/0..**

**NUDO 4 VIAS**  
JOINT À 4 VOIES  
4 WAY JOINT  
GIUNTO 4 VIE  
**3988/0..**

**NUDO 5 VIAS**  
JOINT À 5 VOIES  
5 WAY JOINT  
GIUNTO 5 VIE  
**3984/0..**

**NUDO 6 VIAS**  
JOINT À 6 VOIES  
6 WAY JOINT  
GIUNTO 6 VIE  
**3986/0..**

**NUDO 3 VIAS "T"**  
JOINT À 3 VOIES "T"  
"T" 3 WAY JOINT  
GIUNTO 3 VIE "T"  
**3987/0..**

**NUDO 2 VIAS**  
JOINT À 2 VOIES  
2 WAY JOINT  
GIUNTO 2 VIE  
**3985/0..**

**TUBO 25X25 mm**  
TUBE 25X25 mm  
TUBE 25x25 mm  
TUBO 25x25 mm  
**3989/0..**

CR. BILLO CH. FOU BR. CHR CR. ILLC.	BLANCO BLANC WHITE BIANCO	NEGRO NOR BLACK NERO	COLOR COULEUR COLOR COLORE			
32	OB	ON	OP			
Zn	25x25 mm			€/u		
		o	o			
Zn	25x25 mm			€/u		
		o	o			
Zn	25x25 mm			€/u		
		o	o			
Zn	25x25mm			€/u		
		o	o			
Zn	25x25mm			€/u		
		o	o			
Zn	20x20mm			€/u		
		o	o			
Zn	25x25mm			€/u		
		o	o			
				€/u		
		o	o			
				€/u		
		o	o			
				€/u		
		o	o			

### OTROS ACCESORIOS



**PORTAESTANTE TUBULAR**  
PORTE-ÉTAGÈRE TUBULAIRE  
TUBULAR SHELF HOLDER  
PORTA RIPIANO TUBOLARE  
**3933/032**

**PESTAÑA ESTANTE ANTIDESLIZANTE**  
SHELF SUPPORT  
TAQUET  
REGGIPIANO  
**3824/032**

**PINZA ESTANTE VIDRIO BLOQUEO SEGURIDAD**  
TAQUET MÉTALLIQUE AUTOBLOQUANT VERRE  
METALLIC GLASS SHELF-BLOCKING HOLDER  
REGGICRISTALLO CON BLOCCO  
**1440/032**

**VENTOSA**  
VENTOUSE  
SUCTION  
VENTOSA  
**2556/009**

**VENTOSA**  
VENTOUSE  
SUCTION  
VENTOSA  
**319/009**

**NIVELADOR M10**  
VÉRIN M10  
LEVELLER M10  
PIEDINO LIVELLATORE M10  
**3813/00N**

**RUEDA M10**  
ROUE  
CASTOR  
RUOTA  
**232/00N**

Fe	∅ 5 mm	16 mm	€/u
		o	
Zn	∅ 5 mm		€/u
		o	
			€/u
		o	
plas	∅14	7 3922	€/u
		o	
plas	∅20	7 3922	€/u
		o	
plas	M10		€/u
		o	
plas	M10 ∅50	30kg/u	€/u
		o	

### TAPONES



**TAPÓN TUBO 25X25**  
EMBOUIT  
END-CAP  
COPRITESTA  
**3911/032**

**TAPÓN M10 TUBO 20X20**  
END-CAP with M10 hole  
EMBOUIT avec m10 trou  
COPRITESTA con foro M10  
**3912/000**

**ANCLAJE TUBO 25X25**  
FIXATION TUBE  
TUBO FIXING  
FISSAGGIO TUBO  
**3929/032**

### TUBO 25X25



**TUBO 25X25 mm**  
TUBE 25X25 mm  
TUBE 25x25 mm  
TUBO 25x25 mm  
**3910/3..**

Fe	L 3 m	25x25x1,2	€/u
		o	



PORTA

RÓTULOS 5391/1..

\* MADERA NO INCLUIDA

COMPATIBLE  
KADÍ PRIMO



MATERIAL RÓTULO \*  
NO INCLUIDO

CARTELA CON CONECTOR  
PARA LETREROS CON  
ILUMINACIÓN  
5391/0..

SIN MONTAJE

Placard avec  
connecteur pour  
enseignes lumineuses.  
Placard with connector  
for illuminated signs.  
Cartello con connettore  
per insegne luminose.

1M máx.  
 7  
cm

Fe 72 mm medida útil

BLANCO BLANC WHITE BIANCO	NEGRO NOR BLACK NERO	COLOR COULEUR COLOR COLORE
OB	ON	OP

<input type="radio"/>	<input type="radio"/>	<input type="radio"/>
-----------------------	-----------------------	-----------------------

€/u

ESTANTE

MADERA 5896/1..

COMPATIBLE  
KADÍ PRIMO



MADERA \*  
NO INCLUIDA

ESTANTE DE MADERA  
CON ILUMINACIÓN  
FRONTAL EMPOTRADA  
Y PERFIL DE ALUMINIO  
5896/1..

SIN MONTAJE

Étagère en bois avec  
éclairage zénithal monté sur  
l'étagère  
Wooden shelf with zenithal  
lighting mounted on the shelf  
Ripiano legno con  
illuminazione zenitale  
impotrata nel ripiano

1M máx.  
 28  
cm

PL. M ALU. M ALU. M ALL. NAT	BLANCO WHITE BIANCO	NEGRO BLACK NERO	COLOR COULEUR COLOR COLORE
O1	OB	ON	OP

<input type="radio"/>	<input type="radio"/>	<input type="radio"/>
-----------------------	-----------------------	-----------------------

€/u

SISTEMA CUT-LINE

SISTEMA DE PERFIL DE ALUMINIO CON LED  
INCORPORADO

SE PUEDE ENCASTRAR A LA MADERA O AUTOADHESIVAR

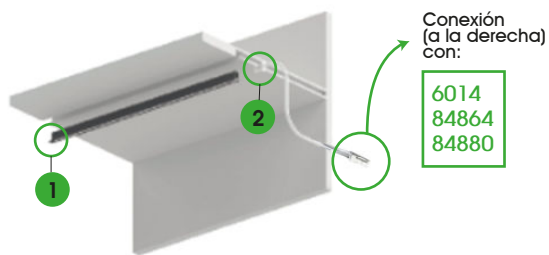

Conexión  
(a la derecha)  
con:

6014  
84864  
84880

CORTE TOTALMENTE LIBRE,  
SIN LIMITES DE MEDIDAS

SE CORTA TODA LA ESTRUCTURA Y EL LED  
A LA MEDIDA DESEADA Y SE REMATA  
CON LOS TAPONES FINALES POR AMBOS LADOS

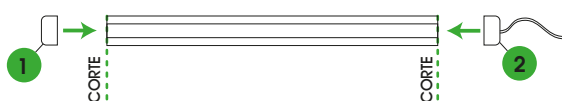

1 Tapón simple / 2 Tapón con  
conexión (derecha)

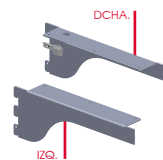

Kit 2 tarjetas:  
DERECHA (con  
conector) +  
IZQUIERDA

KIT CARTELAS ESTANTE MADERA  
CON ILUMINACIÓN  
KIT SUPPORTS BOIS ILLUMINATION  
WOOD LIGHTING BRACKETS KIT  
KIT MENSOLE LEGNO  
ILLUMINAZIONE

5381/0..

Fe	4890	€/u
	282 mm medida útil	

<input type="radio"/>	<input type="radio"/>	<input type="radio"/>
-----------------------	-----------------------	-----------------------



Medidas  
mecanizado  
16 x 6.8 mm

KIT PERFIL ALUMINIO CON  
DIFUSOR  
KIT PROFIL EN ALUMINIUM  
AVEC DIFFUSEUR  
KIT PROFILO IN ALLUMINIO  
CON DIFFUSORE

3971/1..

Al	2M	18x9mm	€/m
----	----	--------	-----

<input type="radio"/>
-----------------------

DIFERENTES POSICIONES DEL DIFUSOR (RECTO / INCLINADO)

PERFIL DE ALUMINIO CON LED  
INCORPORADO  
PROFILÉ EN ALUMINIUM AVEC LED  
INTÉGRÉE  
ALUMINIUM PROFILE WITH BUILT-IN LED  
PROFILO IN ALLUMINIO CON LED  
INTEGRATO

6025/301 4000K  
6026/301 5000K

SET CONECTOR + TAPA  
CABLE 40CM  
6030/041

GRAPAS  
6031/041

Pla	3 m	€/u
	CRI>90	9,6W/24V

LED CON MINI-CONECTOR  
24V  
BANDE LED AVEC MINI-PLUG  
24V  
LED STRIP WITH MINI-PLUG  
24V  
STRACIA LED CON  
MINI-PLUG 24V

126 diodos (20λ);  
cortable cada  
5.5 cm.  
Cable, fil. wire,  
cavo: 40cm  
Ancho 8 mm

flexible y con  
cinta adhesiva  
fleible and  
self-adhesive

4890/009

Pla	1 m	5000 K	€/u
	CRI>90	9,6 W 24V	



### ESTANTE

### VIDRIO 5895/1..

\* Recomendamos usar vidrios segurizados o laminados. (NO INCLUIDO)

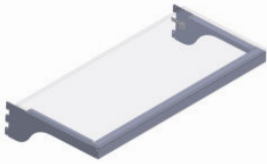

**VIDRIO NO INCLUIDO** \*

ESTANTE DE VIDRIO CON ILUMINACIÓN FRONTAL  
**5895/1..**

**MONTADO**

Étagère en verre avec éclairage avant  
Glass shelf with front lighting  
Ripiano vetro con illuminazione frontale

1M máx. 29 cm

PARA MADERA O VIDRIO



€/u

PL. M	BLANCO	NEGRO	COLOR
ALU. M	BLANC	NOIR	COULEUR
ALU. M	WHITE	BLACK	COLOR
ALL. NAT	BANCO	NERO	COLORE
01	0B	0N	0P

### ESTANTE

### VIDRIO 5894/1..

ESTANTE DE VIDRIO CON ILUMINACIÓN CENITAL FRONTAL  
**5894/1..**

**MONTADO**

Étagère en verre avec éclairage zenithal frontal  
Glass shelf with frontal zenithal lighting  
Ripiano di vetro con illuminazione zenitale frontale

1M máx. 27 cm

PARA MADERA O VIDRIO



€/u

PLÁSTICO	BLANCO	NEGRO	COLOR
PLASTIQUE	BLANC	NOIR	COULEUR
PLASTICA	WHITE	BLACK	COLOR
PLASTICA	BANCO	NERO	COLORE
09	0B	0N	0P

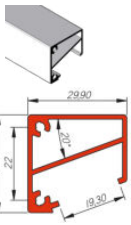

PERFIL ALUMINIO  
PROFIL EN ALUMINIUM  
ALUMINIUM PROFILE  
PROFILO DI ALUMINIO  
**4744/1..**

Al		5 m	30x30	€/m
Ⓞ 84602				

o o o o

Pla		2 m	Ⓞ 4744	€/m
-----	--	-----	--------	-----

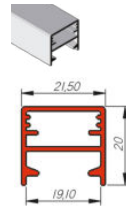

PERFIL ALUMINIO  
PROFIL EN ALUMINIUM  
ALUMINIUM PROFILE  
PROFILO DI ALUMINIO  
**4748/1..**

Al		6 m	21,5x20	€/m
Ⓞ 4893				

o o o

Pla	Ⓞ 4892 - 4894	€/m
2 m		



DIFUSOR PLÁSTICO MATE  
DIFFUSEUR EN PLASTIQUE MAT  
MATT PLASTIC DIFFUSOR  
DIFUSORE PLASTICO OPACO  
**84602/109**

PLÁSTICO	PLASTIQUE	PLASTIC	PLASTICA
09	o		



DIFUSOR PLÁSTICO MATE  
DIFFUSEUR EN PLASTIQUE MAT  
MATT PLASTIC DIFFUSOR  
DIFUSORE PLASTICO OPACO  
**4893/109**

o

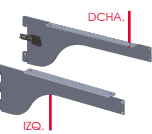

KIT CARTELAS ESTANTE VIDRIO CON ILUMINACIÓN  
KIT SUPPORTS VERRE  
ILLUMINATION  
GLASS LIGHTING BRACKETS KIT  
KIT MENSOLE VETRO  
ILLUMINAZIONE  
**3862/0..**

Fe	Ⓞ 4744-2556-4890	€/u
292 mm medida útil		

o o o

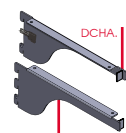

KIT CARTELAS ESTANTE VIDRIO CON ILUMINACIÓN  
KIT SUPPORTS VERRE  
ILLUMINATION  
GLASS LIGHTING BRACKETS KIT  
KIT MENSOLE VETRO  
ILLUMINAZIONE  
**5385/0..**

Fe	Ⓞ 4744-2556-4890	€/u
270 mm medida útil		

o o o

Cada cartela tiene 2 taladros para usar 1 perfil 4744

Kit 2 cartelas: DERECHA (con conector) + IZQUIERDA



LED CON MINI-CONECTOR 24V  
BANDE LED AVEC MINI-PLUG 24V  
LED STRIP WITH MINI-PLUG 24V  
STRACIA LED CON MINI-PLUG 24V  
**4890/109**

Pla		1 m	⚡ 5000 K	€/u
Ⓞ CRI>90 Ⓞ 9,6 W 24V				

o

126 diodos (20λ); cortable cada 5.5 cm  
Cable, fil, wire, cavo: 26cm  
Ancho 8mm

flexible y con cinta adhesiva  
flexible and self-adhesive



126 diodos (20λ); cortable cada 5.5 cm  
Cable, fil, wire, cavo: 26cm  
Ancho 8mm

flexible y con cinta adhesiva  
flexible and self-adhesive

LED CON MINI-CONECTOR 24V  
BANDE LED AVEC MINI-PLUG 24V  
LED STRIP WITH MINI-PLUG 24V  
STRACIA LED CON MINI-PLUG 24V  
**4890/109**

Pla		1 m	⚡ 5000 K	€/u
Ⓞ CRI>90 Ⓞ 9,6 W 24V				

o



VENTOSA TRANSPARENTE  
VENTOUSE  
SUCITON  
VENTOSA  
**2556/009**

Pla	Ⓞ 14 mm	Ⓞ 4880	€/u
-----	---------	--------	-----

o



VENTOSA TRANSPARENTE  
VENTOUSE  
SUCITON  
VENTOSA  
**2556/009**

Pla	Ⓞ 14 mm	Ⓞ 4880	€/u
-----	---------	--------	-----

o



**\*ESTANTE**

**VIDRIO 5890/1..**

\* Recomendamos usar vidrios securizados o laminados. (NO INCLUIDO)



**VIDRIO \* NO INCLUIDO**

ESTANTE DE VIDRIO RETROILUMINADO \*5890/1..

**MONTADO**

Étagère en verre extra claire rétro-éclairé  
Blacklit optical glass shelf  
Ripiano vetro extralight retroilluminato

1M máx. 30 cm

PL. M	BLANCO	NEGRO	COLOR
ALU. M	BLANC	NOIR	COULEUR
ALU. M	WHITE	BLACK	COLOR
ALL. NAT	BANCO	NERO	COLORE
01	0B	0N	0P

€/u

**\*ESTANTE**

**VIDRIO 5891/1..**



**VIDRIO \* NO INCLUIDO**

ESTANTE DE VIDRIO CON ILUMINACIÓN FRONTAL \*5891/1..

**MONTADO**

Étagère en verre avec éclairage zénithal frontal  
Glass shelf with frontal zenithal lighting  
Ripiano di vetro con illuminazione zenitale frontale

1M máx. 30 cm

PL. M	BLANCO	NEGRO	COLOR
ALU. M	BLANC	NOIR	COULEUR
ALU. M	WHITE	BLACK	COLOR
ALL. NAT	BANCO	NERO	COLORE
01	0B	0N	0P

€/u



Junta goma incluida  
joint en caoutchouc  
inclus rubber gasket  
includet giunta di gomma inclusa

PERFIL ALUMINIO PROFIL LAME D'ALUMINIUM ALUMINIUM SLATWALL PROFILE PROFILO DOGATO ALLUMINIO \*362/1...

Al	5 m	6-8mm	€/m
	361/109		

\*o \*o \*o \*o

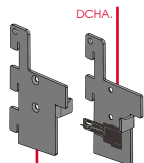

Con perfil 362  
Kit 2 carterías:  
DERECHA (con conector) + IZQUIERDA

KIT CARTELAS ESTANTE VIDRIO CON ILUMINACIÓN KIT SUPPORTS VERRE ILLUMINATION GLASS LIGHTING BRACKETS KIT KIT MENSOLE VETRO ILLUMINAZIONE \*5384/0..

Fe	362 - 4890	€/u
	53 mm medida útil	

\*o \*o \*o



126 diodos (20λ); cortable cada 5.5 cm  
Cable, fil, wire, cavo: 26cm  
Ancho 8mm  
flexible y con cinta adhesiva  
fleible and self-adhesive

LED CON MINI-CONECTOR 24V BANDE LED AVEC MINI-PLUG 24V LED STRIP WITH MINI-PLUG 24V STRIACIA LED CON MINI-PLUG 24V \*4890/109

PLÁSTICO PLASTIQUE PLASTIC PLASTICA	09
--	----

o

Pla	1 m	5000 K	€/u
	CRI>90	9,6 W 24V	

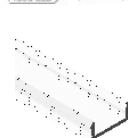
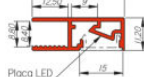

PERFIL ALUMINIO PROFIL EN ALUMINIUM ALUMINIUM PROFILE PROFILO DI ALLUMINIO \*4892/1..

Al	5 m	32x11,2	€/m
	4893 - 4894		

o o o o

DIFUSOR DE PLÁSTICO MATE DIFFUSEUR EN PLASTIQUE MAT MATT PLASTIC DIFFUSOR DIFUSORE PLASTICO OPACO \*4893/109

Pla	4892 - 4894	€/m
	2 m	

o

KIT TAPAS FINALES LATERALES COUVERTURE LATÉRALE FINALE LATERAL END CAP COPERTURA LATERALE FINALE \*4894/0..

Pla	32x11,2 mm	€/u
	4892	

o o

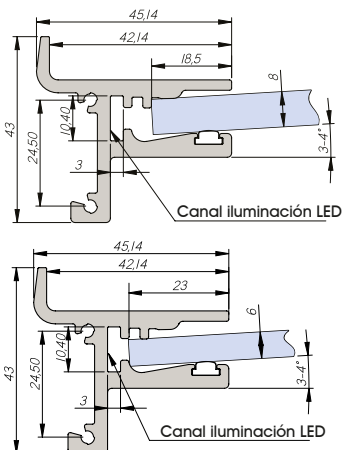

**ES** • MÁXIMA MEDIDA ESTANTE RECOMENDADA: 100 X 30 CM.

**FR** • Maximum recommended shelf size: 100 x 30 cm.

**IT** • Dimensione massima raccomandata dello scaffale: 100 x 30 cm.

**EN** • Taille maximale de l'étagère recommandée: 100 x 30 cm.



### PENDERIE 5897/1..

\* MADERA NO INCLUIDA

KIT compuesto por:  
- Cartelas Ref.5382  
-Tubo rectangular Ref.4900/12B  
-LED de 1m



VIDRIO / MADERA NO INCLUIDO

ESTANTE + BARRA DE CUELGUE LATERAL CON ILUMINACIÓN Y PROTECCIÓN PLÁSTICA SUPERIOR 5897/1..

#### MONTADO

Tablette + barre de suspension laterale avec éclairage  
Shelf + side hanging bar with lighting  
Mensola + barra appendiabiti laterale con illuminazione

1M máx. 29 cm

PLÁSTICO PLASTIQUE PLASTIC PLASTICA	BLANCO BLANC WHITE BANCO	NEGRO NOIR BLACK NERO	COLOR COULEUR COLOR COLORE
09	OB	ON	OP

### BARRA DE CUELGUE LATERAL 5898/1..

KIT compuesto por:  
- Cartelas Ref.5383  
-Tubo rectangular Ref.4900/12B  
-LED de 1m



BARRA DE CUELGUE LATERAL CON ILUMINACIÓN Y PROTECCIÓN PLÁSTICA SUPERIOR 5898/1..

#### MONTADO

Barre de suspension laterale avec éclairage  
Side hanging bar with lighting  
Barra appendiabiti laterale con illuminazione

1M máx. 29 cm

PL. M ALU. M ALU. M ALL. NAT	BLANCO BLANC WHITE BANCO	NEGRO NOIR BLACK NERO	COLOR COULEUR COLOR COLORE
01	OB	ON	OP

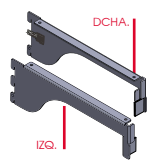

Kit 2 cartelas: DERECHA (con conector) + IZQUIERDA

KIT CARTELAS BARRA ACCESORIOS  
KIT SUPPORT BARRE ACCESSOIRES  
KIT BRACKET FOR ACCESSORIES ROD  
KIT MENSOLA TUBO PORTA-ACCESSORI 5382/00.

Fe	⊙ 4900	€/u
	290 mm medida útil	

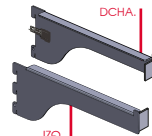

Kit 2 cartelas: DERECHA (con conector) + IZQUIERDA

KIT CARTELAS BARRA ACCESORIOS  
KIT SUPPORT BARRE ACCESSOIRES  
KIT BRACKET FOR ACCESSORIES ROD  
KIT MENSOLA TUBO PORTA-ACCESSORI 5383/00.

Fe	⊙ 4900	€/u
	290 mm medida útil	

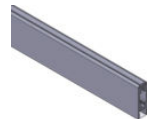

LED no incluido. LED recomendado de 5mm de ancho. Incluye perfil de plástico superior y difusor interior.

TUBO RECTANGULAR PARA ILUMINACIÓN 30X10MM CON PLETINA DE REFUERZO  
KIT TUBE RECTANGULAIRE POUR ECLAIRAGE 30X10MM AVEC PLAQUE DE RENFORT  
KIT RECTANGULAR TUBE FOR LIGHTING 30X10MM WITH REINFORCING PLATE  
KIT TUBO RETTANGOLARE PER ILLUMINAZIONE 30X10MM CON PIASTRA DI RINFORZO 4900/12.

CARGA LIGERA max. 30KG

Al	⊔ 1 m	30x10	€/u
	⊙ 4901		

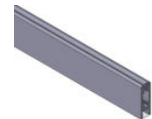

LED no incluido. LED recomendado de 5mm de ancho. Incluye perfil de plástico superior y difusor interior.

TUBO RECTANGULAR PARA ILUMINACIÓN 30X10MM CON PLETINA DE REFUERZO  
KIT TUBE RECTANGULAIRE POUR ECLAIRAGE 30X10MM AVEC PLAQUE DE RENFORT  
KIT RECTANGULAR TUBE FOR LIGHTING 30X10MM WITH REINFORCING PLATE  
KIT TUBO RETTANGOLARE PER ILLUMINAZIONE 30X10MM CON PIASTRA DI RINFORZO 4900/12.

CARGA LIGERA max. 30KG

Al	⊔ 1 m	30x10	€/u
	⊙ 4901		



182 diodos (20λ); cortable cada 3.8 cm  
Cable, fil. wire, cavo: 40cm  
Ancho 5mm

flexible y con cinta adhesiva  
fleible and self-adhesive

LED CON MINI-CONECTOR 24V  
BANDE LED AVEC MINI-PLUG 24V  
LED STRIP WITH MINI-PLUG 24V  
STRIACIA LED CON MINI-PLUG 24V 4910/109

Pla	⊔ 1 m	5000 K	€/u
	⊙ CRI>90	⊠ 15,3W 24V	



182 diodos (20λ); cortable cada 3.8 cm  
Cable, fil. wire, cavo: 40cm  
Ancho 5mm

flexible y con cinta adhesiva  
fleible and self-adhesive

LED CON MINI-CONECTOR 24V  
BANDE LED AVEC MINI-PLUG 24V  
LED STRIP WITH MINI-PLUG 24V  
STRIACIA LED CON MINI-PLUG 24V 4910/109

Pla	⊔ 1 m	5000 K	€/u
	⊙ CRI>90	⊠ 15,3W 24V	

PLÁSTICO  
PLASTIQUE  
PLASTIC  
PLASTICA  
09



VENTOSA TRANSPARENTE  
VENTOUSE  
SUCITON  
VENTOSA 2556/009

Pla	⊙ 14 mm	⊙ 4880	€/u
-----	---------	--------	-----

### SISTEMA CUT-LINE

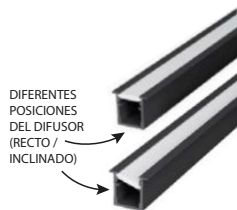

DIFFERENTES POSICIONES DEL DIFUSOR (RECTO / INCLINADO)

PERFIL DE ALUMINIO CON LED INCORPORADO  
PROFILÉ EN ALUMINIUM AVEC LED INTÉGRÉE  
ALUMINIUM PROFILE WITH BUILT-IN LED  
PROFILO IN ALLUMINIO CON LED INTEGRATO

6025/301 4000K  
6026/301 5000K

SET CONECTOR + TAPA CABLE 40CM 6030/041

GRAPAS 6031/041

PL. M ALU. M ALU. M ALL. NAT	01
---------------------------------------	----

Pla	⊔ 3 m	€/u
	⊙ CRI>90	⊠ 9,6W 24V

### SISTEMA DE PERFIL DE ALUMINIO CON LED INCORPORADO SE PUEDE ENCASTRAR A LA MADERA O AUTOADHESIVAR

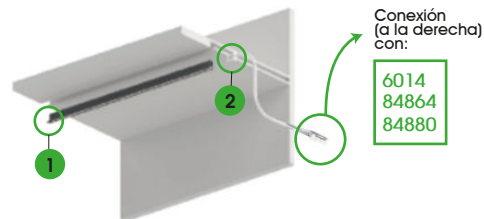

Conexión (a la derecha) con:

6014  
84864  
84880

### CORTE TOTALMENTE LIBRE, SIN LIMITES DE MEDIDAS SE CORTA TODA LA ESTRUCTURA Y EL LED A LA MEDIDA DESEADA Y SE REMATA CON LOS TAPONES FINALES POR AMBOS LADOS





**BARRA ACCES. FR.**

**5901/1..**

KIT compuesto por:  
- Cartelas Ref.5380  
-Tubo rectangular  
Ref.4900/12B  
-LED de 1m



BARRA DE CUELGUE PARA  
ACCESORIOS FRONTALES  
CON ILUMINACIÓN Y  
PROTECCIÓN PLÁSTICA  
SUPERIOR

**5901/1..**

**MONTADO**

Barre de suspension pour  
accessoires avant avec  
éclairage  
Hanger bar for front  
accessories with lighting  
Barra appendiabli per  
accessori frontali con  
illuminazione

1M máx.  
7  
cm

PL. M	BLANCO	NEGRO	COLOR
ALU. M	BLANC	NOR	COULEUR
ALU. M	WHITE	BLACK	COLOR
ALL. NAT	BANCO	NERO	COLORE
01	0B	0N	0P

€/u

o o o

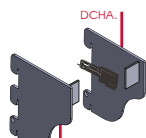

Kit de 2  
cartelas:  
DERECHA (con  
conector) +  
IZQUIERDA

**KIT CARTELAS BARRA  
ACCESORIOS**  
KIT SUPPORT BARRÉ  
ACCESSOIRES  
KIT BRACKET FOR  
ACCESSORIES ROD  
KIT MENSOLA TUBO  
PORTA-ACCESSORI

**5380/0..**

Fe	4900	€/u
71 mm medida útil		

o o o

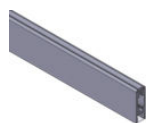

LED no incluido.  
LED  
recomendado de  
5mm de ancho.  
Incluye perfil de  
plástico superior y  
difusor interior.

**TUBO RECTANGULAR PARA  
ILUMINACIÓN 30X10MM CON  
PLETINA DE REFUERZO**  
KIT TUBE RECTANGULAIRE POUR  
ECLAIRAGE 30X10MM AVEC  
PLAQUE DE RENFORT  
KIT RECTANGULAR TUBE FOR  
LIGHTING 30X10MM WITH  
REINFORCING PLATE  
KIT TUBO RETTANGOLARE PER  
ILLUMINAZIONE 30X10MM CON  
PIASTRA DI RINFORZO

**4900/12.**

**CON ALMA DE  
ACERO INOX**

**CARGA LIGERA**

Al	1 m	€/u
30x10	4901	

o o o



182 diodos (20λ);  
cortable cada  
3,8 cm  
Cable, fil. wire,  
cavo: 45 mm  
Ancho 5mm

flexible y con  
cinta adhesiva  
fleible and  
self-adhesive

**LED CON  
MINI-CONECTOR 24V**  
BANDE LED AVEC  
MINI-PLUG 24V  
LED STRIP WITH  
MINI-PLUG 24V  
STRACIA LED CON  
MINI-PLUG 24V  
**4901/109**

Pla	1 m	5000 K	€/u
CRI>90		15,3W 24V	

PLÁSTICO  
PLASTIQUE  
PLASTIC  
PLASTICA

**09**

o

**ACCESORIO CONECTOR**

COLOR  
COULEUR  
COLOR  
COLORE

**0P**

**KIT LUZ  
CENTAL**



**Cartela**

X1

**Conector**

X1

**KIT ACCESORIO CONECTOR DE  
PLÁSTICO PARA ILUMINACIÓN  
CENTAL**  
KIT D'ACCESSOIRES DE  
CONNECTEUR EN PLASTIQUE  
POUR ÉCLAIRAGE AÉRIEN  
PLASTIC CONNECTOR  
ACCESSORY KIT FOR OVERHEAD  
LIGHTING  
KIT ACCESSORI CONNETTORE IN  
PLASTICA PER ILLUMINAZIONE  
AMBIENTALE

**5330/010**

o

**Ejemplo de aplicación:**

La pieza actua como soporte del  
conector el qual da conexión a la luz  
superior, permitiendo iluminar los plafones  
superiores de la estructura.

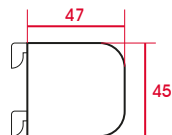

**EJEMPLO DE APLICACIÓN**

Barras de  
accesorios con  
cuelgue frontal.



**NO APTO PARA  
PERROQUET  
SOLO GANCHO**

**CARGA LIGERA**

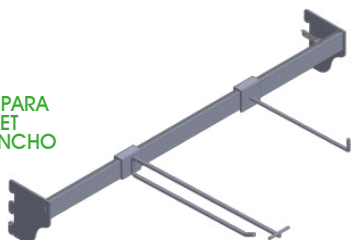



**SISTEMA CUT-LINE**

**PERFIL DE ALUMINIO CON LED INCORPORADO**  
**PROFILÉ EN ALUMINIUM AVEC LED INTÉGRÉE**  
**ALUMINIUM PROFILE WITH BUILT-IN LED**  
**PROFILO IN ALLUMINIO CON LED INTEGRATO**

6025/301 4000K  
 6026/301 5000K

**SET CONECTOR + TAPA CABLE 40CM**  
 6030/041

**GRAPAS**  
 6031/041

PL. M	ALU. M	ALU. M	ALL. NAT.
01			
Pla	3 m	€/u	
	CRI > 90	9,6W/24V	

**SISTEMA DE PERFIL DE ALUMINIO CON LED INCORPORADO**

**SE PUEDE ENCASTRAR A LA MADERA O AUTOADHESIVAR**

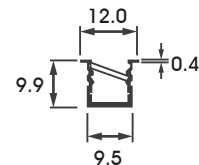
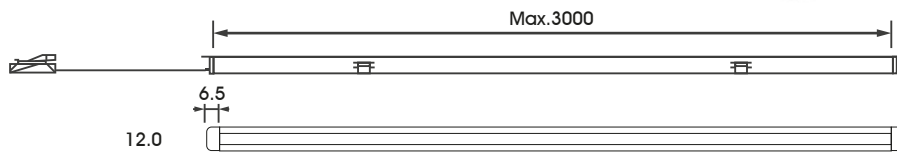
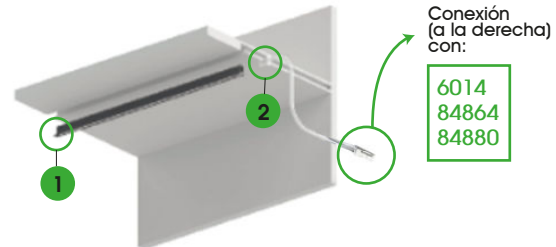

**CORTE TOTALMENTE LIBRE, SIN LIMITES DE MEDIDAS**

SE CORTA TODA LA ESTRUCTURA Y EL LED A LA MEDIDA DESEADA Y SE REMATA CON LOS TAPONES FINALES POR AMBOS LADOS

1 Tapón simple / 2 Tapón con conexión (derecha)

**DISTINTAS MANERAS DE POSICIONAR EL LED SEGÚN NECESIDAD DE DIRECCIONAR LA LUZ**

**PERFILES CON ILUMINACIÓN**

	<b>PERFIL ALUMINIO</b> PROFIL EN ALUMINIUM ALUMINIUM PROFILE PROFILO DI ALUMINIO	4744/1..	Al	5 m	30x30	€/m	01	0B	0N	0P
	<b>PERFIL ALUMINIO</b> PROFIL EN ALUMINIUM ALUMINIUM PROFILE PROFILO DI ALUMINIO	4748/1..	Al	6 m	21,5x20	€/m				
	<b>PERFIL ALUMINIO</b> PROFIL LAME D'ALUMINIUM ALUMINIUM SLATWALL PROFILE PROFILO DOGATO ALLUMINIO	*362/1...	Al	5 m	6-8mm	€/m	*	*	*	*
	<b>PERFIL ALUMINIO</b> PROFIL EN ALUMINIUM ALUMINIUM PROFILE PROFILO DI ALUMINIO	4892/1..	Al	5 m	32x11,2	€/m				
	<b>TUBO RECTANGULAR PARA ILUMINACIÓN</b> 30X10MM CON PLETINA DE REFUERZO KIT TUBE RECTANGULAIRE POUR ECLAIRAGE 30X10MM AVEC PLAQUE DE RENFORT KIT RECTANGULAR TUBE FOR LIGHTING 30X10MM WITH REINFORCING PLATE KIT TUBO RETTANGOLARE PER ILLUMINAZIONE 30X10MM CON PIASTRA DI RINFORZO	4901/12.	Al	1 m	30x10	€/u				

**LEDs**

	<b>LED CON MINI-CONECTOR 24V</b> BANDE LED AVEC MINI-PLUG 24V LED STRIP WITH MINI-PLUG 24V STRIACIA LED CON MINI-PLUG 24V	4901/109	Pl	1 m	CRI > 90	€/u	09
	<b>LED CON MINI-CONECTOR 24V</b> BANDE LED AVEC MINI-PLUG 24V LED STRIP WITH MINI-PLUG 24V STRIACIA LED CON MINI-PLUG 24V	4910/109	Pl	1 m	CRI > 90	€/u	
	<b>LED CON MINI-CONECTOR 24V</b> BANDE LED AVEC MINI-PLUG 24V LED STRIP WITH MINI-PLUG 24V STRIACIA LED CON MINI-PLUG 24V	4890/009	Pl	1 m	CRI > 90	€/u	
	<b>LED CON MINI-CONECTOR 24V</b> BANDE LED AVEC MINI-PLUG 24V LED STRIP WITH MINI-PLUG 24V STRIACIA LED CON MINI-PLUG 24V	4890/109	Pl	1 m	CRI > 90	€/u	



EASY LIGHT - MAGNETIC LED

EASY LIGHT - SISTEMA IMANTADO



Los productos de la familia **EASY LIGHT** tienen **certificado** de conformidad a la directiva comunitaria **2014/30/EU** y al **RoHS 2011/65/EU** y actualizaciones posteriores.

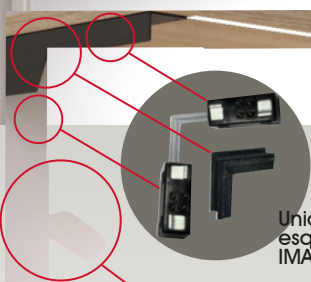
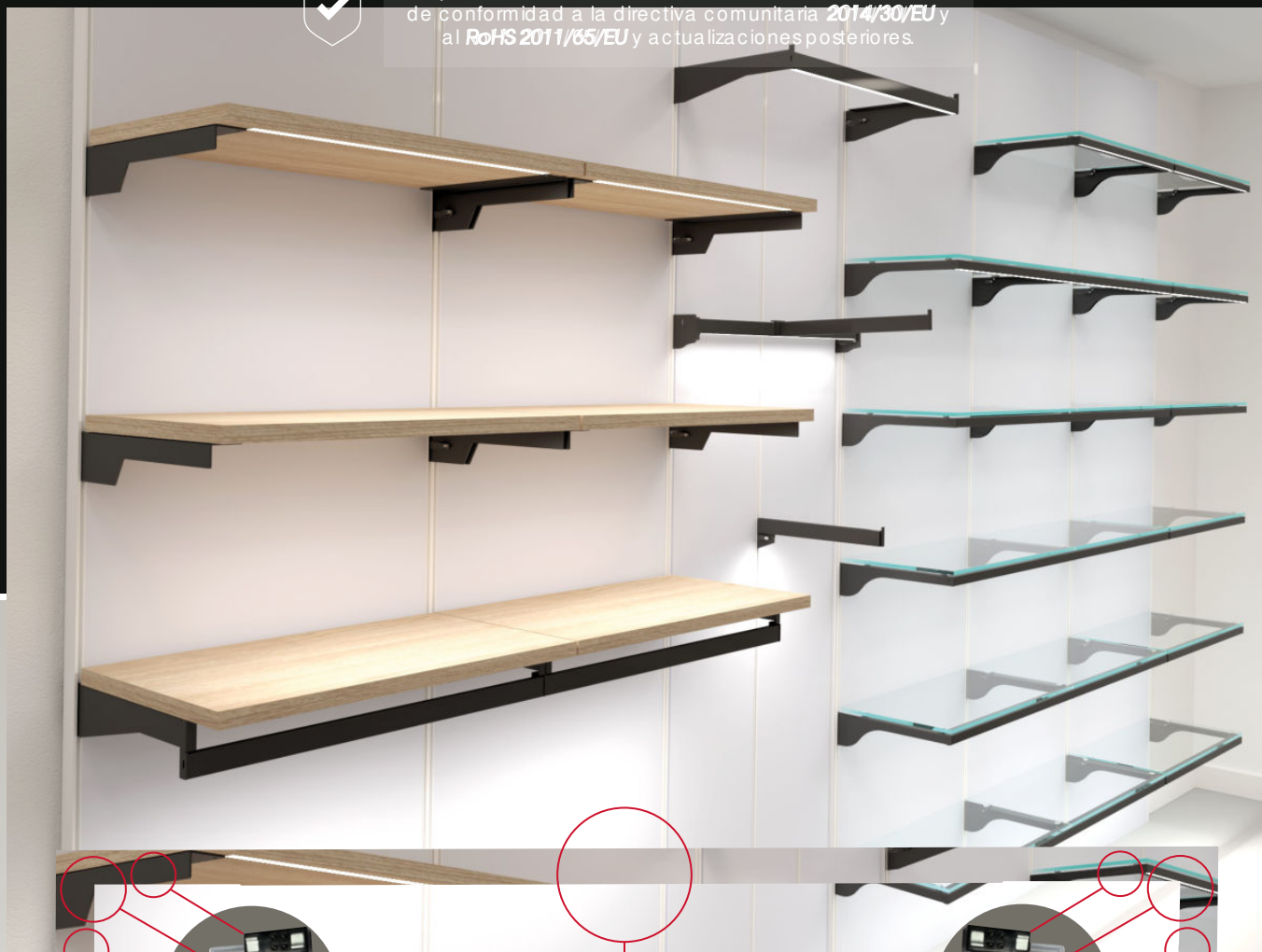

Uniones para esquinas también IMANTADAS

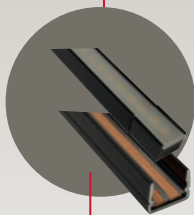

Diferentes tipos de accesorios IMANTADOS

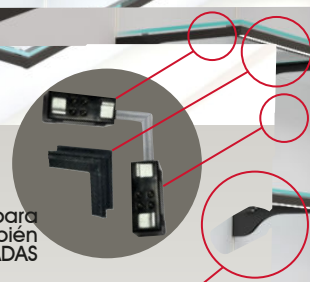

Uniones para esquinas también IMANTADAS

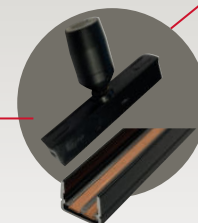

Posibilidad de ENCASTRAR.

\* El cable de corriente pasa por el interior y sale por la parte inferior de la pieza

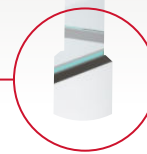
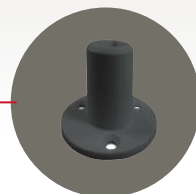



### SISTEMA DE ILUMINACIÓN

- Sistema de riel de suministro eléctrico para módulos de iluminación combinables con imán, perfecto para estantes, gabinetes, escaparates, etc.
- Múltiples métodos y ángulos de instalación (adhesivado, atornillado, encastrado, etc).
- Tamaño pequeño, acabado integrado y apto para espacios estrechos.
- Fácil instalación.
- Sistema de vía de alimentación eléctrica fácilmente conectable. Con diferentes módulos de iluminación combinables.

#### CARRIL

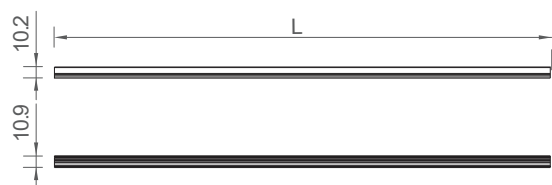

#### SPOT LIGHT

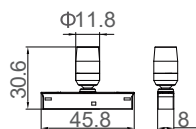

#### STRIP LIGHT

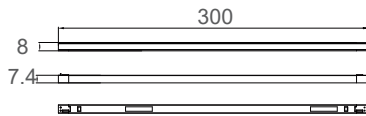

- Instalación a 45° - invisible (Método de instalación: Clips o cinta adhesiva)
- Instalación a 90° - invisible (Método de instalación: Clips)



Los dos métodos anteriores se ajustan a la vitrina y al escaparate

- Instalación montada en superficie (Método de instalación: Clips o cinta adhesiva)



#### INTENSIDAD LUMINOSA

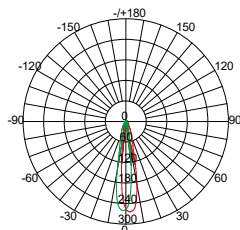

**LOS CABLES CONECTORES DEBEN MANTENER TODOS LA MISMA DIRECCIÓN PARA MANTENER LA POLARIDAD**



Los productos de la familia **EASY LIGHT** tienen **certificado** de conformidad a la directiva comunitaria **2014/30/EU** y al **RoHS 2011/65/EU** y actualizaciones posteriores.

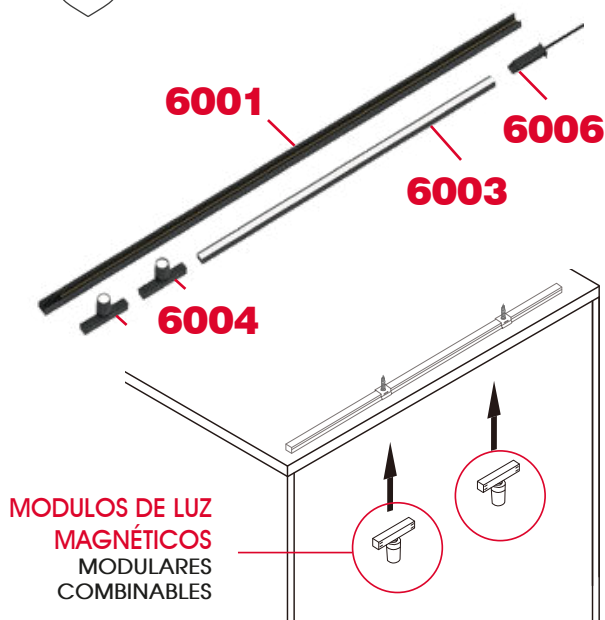

**MODULOS DE LUZ MAGNÉTICOS MODULARES COMBINABLES**

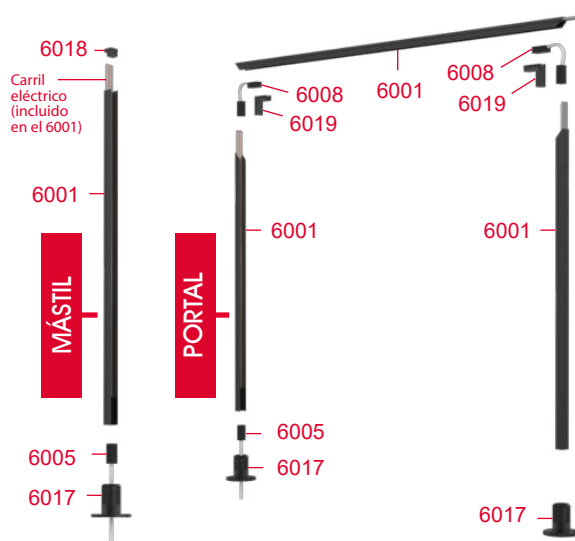

#### ESPECIFICACIONES

	CARRIL	LUZ FOCAL	LUZ LINEAR
<b>TAMAÑO:</b>	Lx10.2x10.9mm (Longitud opcional)	30.6x11.8mm	300x8x8.5mm
<b>ENTRADA NOMINAL:</b>	/	24V DC	24V DC
<b>FUERZA:</b>	/	0.6W	3.5W
<b>FLUJO LUMINOSO (TYP@4000K):</b>	/	38lm	266lm
<b>RA:</b>	/	90	90
<b>EFICIENCIA:</b>	/	67lm/W	75lm/W
<b>IP:</b>	20	20	20
<b>COLOR:</b>	Negro	Negro	Negro
<b>CCT:</b>	/	4000K	4000K
<b>INSTALACIÓN:</b>	Clips / Cinta adh.	Magnética	Magnética



COMPONENTES SISTEMA MAGNETIC LED

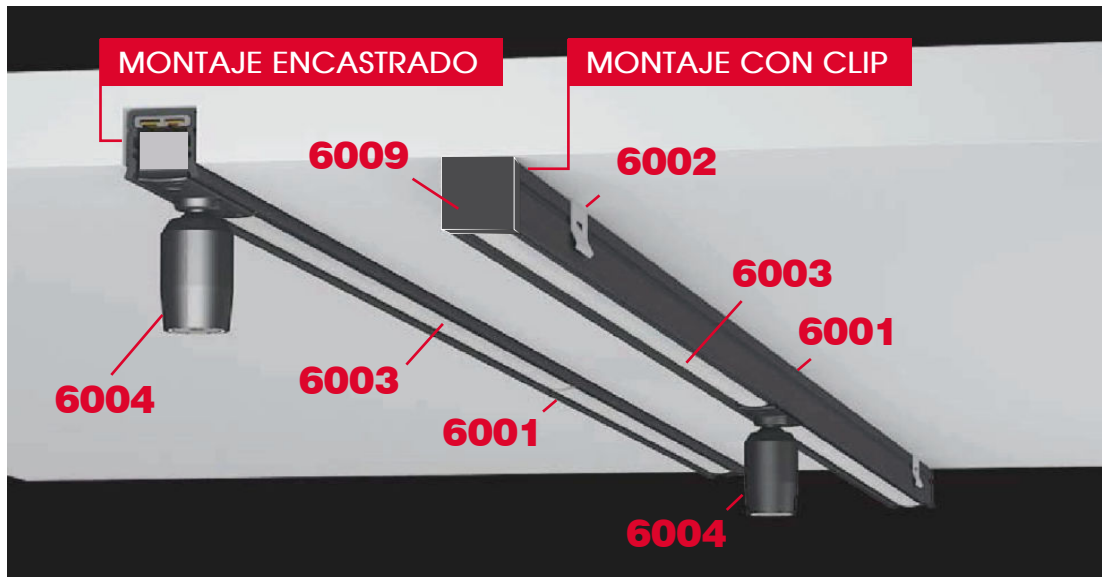

	INOX	SAT	NEGRO			
	INOX	SAT	NOIR			
	S.S.S.	INOX	BLACK			
	INOX	SAT	NERO			
<p>MAGNÉTICO</p>				28	0N	
<p><b>CARRIL ELECTRIFICADO MAGNÉTICO</b> RAIL ÉLECTRIFIÉ MAGNÉTIQUE MAGNETIC ELECTRIFIED RAIL BINARIO ELETRIFICATO MAGNETICO</p> <p><b>6001/20N</b></p>				2 m	€/u	o
<p>MAGNÉTICO</p>				6001-6012	€/u	o
<p><b>CLIP PARA FIJACIÓN</b> CLIP DE FIXATION FIXING CLIP CLIP DI FISSAGGIO</p> <p><b>6002/028</b></p>				4000 K 3,5 W 24V	€/u	o
<p>MAGNÉTICO</p>				30 cm	€/u	o
<p><b>LED ILUMINACIÓN LINEAR</b> ÉCLAIRAGE LINÉAIRE À DEL LED LINEAR LIGHTING ILLUMINAZIONE LINEARE A LED</p> <p><b>6003/00N</b></p>				4000 K 0,8 W 24V	€/u	o
<p>MAGNÉTICO</p>				30 cm	€/u	o
<p><b>MÓDULO DE ILUMINACIÓN FOCAL</b> MODULE PLEINS FEUX SPOTLIGHT MODULE MODULO FARETTO</p> <p><b>6004/00N</b></p>				Placa	€/u	o
<p>30</p> <p>19,5</p> <p>Possibilidad de encastrar (taladro: Ø20mm)</p>				Ø19,5mm	€/u	o
<p><b>BASE (FORMATO VERTICAL)</b> BASE (FORMAT VERTICAL) BASE (VERTICAL FORMAT) BASE (FORMATO VERTICALE)</p> <p><b>6017/00N</b></p>				Placa	€/u	o
<p><b>TAPA DE CARRIL (6001)</b> COUVERCLE DE RAIL (6001) RAIL COVER (6001) COPRIBINARIO (6001)</p> <p><b>6018/00N</b></p>				Placa	€/u	o
<p><b>UNIÓN 90°</b> UNION 90° 90° UNION UNIONE 90°</p> <p><b>6019/00N</b></p>				Placa	€/u	o
<p>MAGNÉTICO</p>					€/u	o
<p><b>CONECTOR MAGNÉTICO CARRIL-DRIVER</b> CONNECTEUR MAGNÉTIQUE RAIL-DRIVER MAGNETIC CONNECTOR RAIL-DRIVER CONNETTORE MAGNETICO RAIL-DRIVER</p> <p><b>6005/00N</b></p>				Placa	€/u	o
<p>MAGNÉTICO</p>				40cm	€/u	o
<p><b>CONECTOR MAGNÉTICO CARRIL-CONECTOR CARTELAS KADI</b> CONNECTEUR MAGNÉTIQUE RAIL-CONNECTEUR SUPPORT KADI MAGNETIC CONNECTOR RAIL-CONNECTOR KADI BRACKET CONNETTORE MAGNETICO BINARIO - CONNETTORE MENSOLA KADI</p> <p><b>6006/00N</b></p>				Placa	€/u	o
<p>MAGNÉTICO</p>				40cm	€/u	o
<p><b>CONECTOR MAGNÉTICO CARRIL-LED UNIVERSAL</b> CONNECTEUR MAGNÉTIQUE RAIL-LED UNIVERSAL MAGNETIC CONNECTOR RAIL-UNIVERSAL LED CONNETTORE MAGNETICO BINARIO-UNIVERSALE LED</p> <p><b>6007/00N</b></p>				Placa	€/u	o
<p>MAGNÉTICO</p>				4 cm	€/u	o
<p><b>CONECTOR MAGNÉTICO CARRIL-CARRIL</b> CONNECTEUR MAGNÉTIQUE RAIL-RAIL MAGNETIC CONNECTOR RAIL-RAIL CONNETTORE MAGNETICO BINARIO - BINARIO</p> <p><b>6008/00N</b></p>				Placa	€/u	o
<p>MAGNÉTICO</p>				15cm	€/u	o
<p><b>DRIVER 100W, 24V / CONECTOR HEMBRA</b> CONDUCTEUR 100W, 24V / CONNECTEUR FEMELLE DRIVER 100W, 24V / FEMALE CONNECTOR DRIVER 100W, 24V / CONNETTORE FEMMINA</p> <p><b>6010/009</b></p>				15cm	€/u	o
<p>6 SALIDAS</p>					€/u	o



## EASY LIGHT - EASY

- Sistema de riel de suministro eléctrico para módulos de iluminación combinables con imán, perfecto para estantes, gabinetes, escaparates, etc.
- Múltiples métodos y ángulos de instalación (adhesivado, atornillado, encastrado, etc).
- Tamaño pequeño, acabado integrado y apto para espacios estrechos.
- Fácil instalación.
- Sistema de vía de alimentación eléctrica fácilmente conectable. Con diferentes módulos de iluminación combinables.

### CARRIL

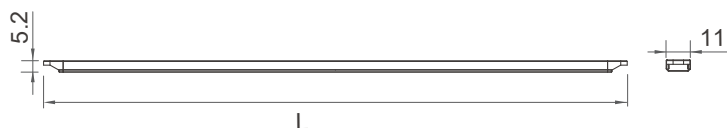

### CABLE

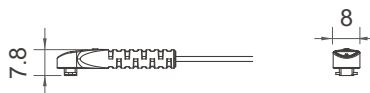

<b>LONGITUD:</b>	Lx11x5.2mm
<b>CABLE DE ENTRADA:</b>	22# AWG UL 2468 CABLE
<b>INPUT:</b>	8A
<b>CABLE DE SALIDA:</b>	22# AWG UL 2468 CABLE
<b>OUTPUT:</b>	3A
<b>MAX. LONGITUD:</b>	2500mm
<b>INSTALACIÓN:</b>	Montaje Magnético, Montaje con Tornillos, Adhesivado
<b>COLOR:</b>	Blanco / Negro

LOS CABLES CONECTORES DEBEN MANTENER TODOS LA MISMA DIRECCIÓN PARA MANTENER LA POLARIDAD



Los productos de la familia **EASY LIGHT** tienen **certificado** de conformidad a la directiva comunitaria **2014/30/EU** y al **RoHS 2011/65/EU** y actualizaciones posteriores.

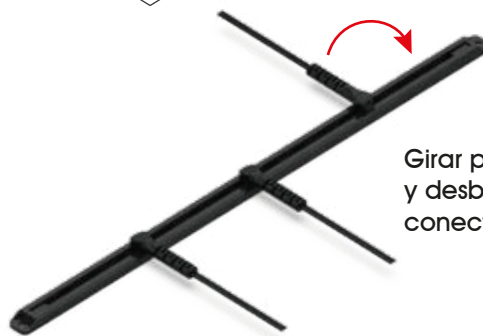

Girar para bloquear y desbloquear el conector.

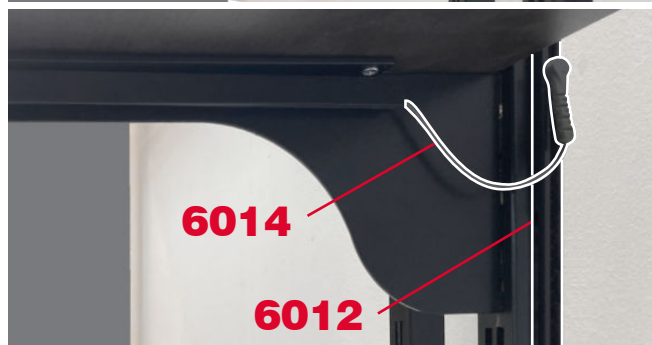
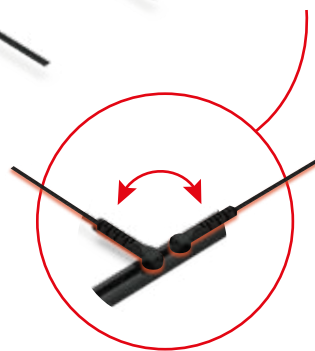



COMPONENTES SISTEMA EASY



**CARRIL ELECTRIFICADO**  
RAIL ELECTRIFIÉ  
ELECTRIFIED RAIL  
BINARIO ELETRIFICATO  
**6012/25.**

BLANCO BLANC WHITE BIANCO	NEGRO NOR. BLACK NERO
OB	ON

Placa 2,5 m 24V €/u

o o



(x2 u.)

**TAPÓN FINAL**  
BOUCHON D'EXTRÉMITÉ  
END PLUG  
TAPPO FINE  
**6011/0..**

€/u

o o



MAGNÉTICO

**CINTA MAGNÉTICA ADHESIVA**  
RUBAN MAGNÉTIQUE ADHÉSIF  
ADHESIVE MAGNETIC TAPE  
NASTRO MAGNETICO ADESIVO  
**6012/000 50M**  
**6012/100 1M**

PLÁSTICO PLASTIQUE PLASTIC PLASTICA
09

€/u o  
€/m o



**CINTA ADHESIVA DOBLE CARA**  
RUBAN MAGNÉTIQUE ADHÉSIF  
ADHESIVE MAGNETIC TAPE  
NASTRO MAGNETICO ADESIVO  
**6012/009 66M**

€/u

o



126 diodos (20λ); cortable  
cada 5,5 cm  
Cable: fil. wire, cavo: 40cm  
Ancho 8 mm  
flexible y con cinta adhesiva  
flexible and self-adhesive

**LED CON MINI-CONECTOR 24V**  
BANDE LED AVEC MINI-PLUG 24V  
LED STRIP WITH MINI-PLUG 24V  
STRACIA LED CON MINI-PLUG  
24V  
**4890/009**

Placa 1 m 5000 K €/u  
CRI > 90 9,6 W 24V

o



**CONECTOR DIVER 6 VÍAS 20CM**  
CONNECTEUR PLONGEUR 6  
VOIES 20CM  
6-WAY DIVER CONNECTOR  
20CM  
CONNETTORE SUBACQUEO A 6  
VIE 20 CM  
**6021/009**

Placa 3 m 230 V 2,5 A €/u

o



**CONECTOR CARRIL-DRIVER /**  
CONECTOR SEGURIDAD ALUSYSTEM  
CONNECTEUR RAIL-DRIVER /  
CONNECTEUR SÉCURITÉ DU ALUSYSTEM  
CONNECTOR RAIL-DRIVER /  
CONNECTOR ALUSYSTEM SECURITY  
CONNETTORE RAIL-DRIVER /  
CONNETTORE LA SICUREZZA ALUSYSTEM  
**6013/0..**

BLANCO BLANC WHITE BIANCO	NEGRO NOR. BLACK NERO
OB	ON

Placa 24V €/u  
1M

o o



**CONECTOR CARRIL-LED / HEMBRA**  
CONNECTEUR RAIL-LED / FEMELLE  
RAIL-LED CONNECTOR / FEMALE  
CONNETTORE RAIL-LED / FEMMINA  
**6014/0..**

Placa 24V €/u  
10cm

o o

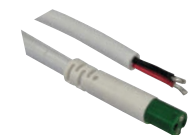

**CABLE CONEXIÓN DRIVER PARA SOLDAR**  
MODULE PLEINS FEUX  
SPOTLIGHT MODULE  
MODULO FARETTO  
**6015/00B**

Placa 1M €/u

o



**DRIVER 100W, 24V /**  
CONECTOR HEMBRA  
CONDUCTEUR 100W, 24V /  
CONNECTEUR FEMELLE  
DRIVER 100W, 24V / FEMALE CONNECTOR  
DRIVER 100W, 24V / CONNETTORE FEMMINA  
**6010/009**

Placa 24V 100W  
€/u  
PLÁSTICO  
PLASTIQUE  
PLASTIC  
PLASTICA  
09

o



**CABLE ALARGO MACHO-HEMBRA 3M**  
CÂBLE D'EXTENSION MÂLE-FEMELLE DE 3 M  
3M MALE-FEMALE EXTENSION CABLE  
CAVO DI PROLUNGA MASCHIO-  
FEMMINA 3M  
**6022/00B**

Placa 3 m 230 V 2,5 A €/u

o



## SISTEMA ILUMINACIÓN PARA MUEBLES DE MADERA

### VARIO



VARIO es una nueva solución de iluminación para la electrificación de estanterías de madera.  
- Los estantes pueden colocarse de manera fácil a cualquier altura sin preocuparse de la conexión eléctrica.  
- Grosor mínimo estante: 22 mm  
- 24 V

VARIO est une nouvelle solution d'éclairage pour l'électrification des étagères en bois.

- Les étagères peuvent être situées facilement quelle hauteur indépendamment de la connexion électrique.

- Épaisseur min. étage: 22 mm  
- 24V

VARIO is a new lighting solution for wood shelves electrification.

- Shelves can be placed easily at any height without worrying about the electrical connections.

- Minimum shelf thickness: 22 mm  
- 24V

VARIO è una nuova soluzione di illuminazione per l'elettificazione di scaffalature in legno.

- Le mensole possono essere posizionate facilmente a qualsiasi altezza senza preoccuparsi delle connessioni elettriche.

- Spessore min. ripiano: 22 mm  
- 24 V



COMPONENTES  
SISTEMA VARIO

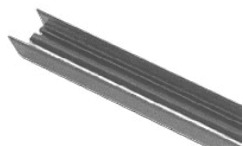

**CARRIL ELECTRIFICADO**  
RAIL D'ALIMENTATION 24V  
POWER RAIL 24V  
BINARIO ELETRIFICATO 24V  
\*4805/309

PLÁSTICO  
PLASTIQUE  
PLASTIC  
PLASTICA  
09  
plas 3000 mm  
24V - máx. 6A €/u



male  
macho

**CONECTOR ALIMENTACIÓN**  
CARRIL - DRIVER  
ALIMENTACION DE CONECTOR  
RAIL-DRIVER  
FEEDER CONNECTOR TRACK - DRIVER  
CONNETTORE BINARIO ELETRIFICATO - DRIVER  
\*4807/049  
UNO POR CARRIL

plas 400 mm  
24V - máx. 6A €/u



female  
hembra

**CONECTOR LED A CARRIL**  
ELECTRIFICADO  
LED CONECTOR A RAIL  
D'ALIMENTATION  
LED CONNECTOR TO POWER RAIL  
CONNETTORE LED A BINARIO ELETRIFICATO  
\*4806/109  
UNO POR ESTANTE

plas 100 mm  
24V - máx. 6A €/u



macho  
male



**PERFIL ALUMINIO + LED**  
ALUMINIUM PROFIL + LED  
ALUMINIUM PROFILE + LED  
ALLUMINIO PROFILO + LED  
\*4809/089 862 mm

Al CRI>85  
9W - 24V 4000 K €/u



female  
hembra

**DRIVER + 6 SALIDAS CON**  
MINI-CONECTORES 24V  
DRIVER + DISTRIBUTEURS 6 SORTIES  
AVEC MINI-PLUG 24V  
DRIVER + DISTRIBUTOR 6 WAYS-BLOCK  
WITH MINI-PLUG 24V  
DRIVER + DISTRIBUTORE 6 USCITE  
CON MINI-PLUG 24V  
\*4770/009

plas 3 m  
100W - 230V > 24V €/u

COMPRANDO EL SISTEMA COMPLETO DESDE EL  
ENCHUFE HASTA EL LED 4809:

- 2 AÑOS DE GARANTIA
- DESCUENTO ADICIONAL DEL 30%

El sistema completo no precisa certificado de instalación de baja tensión

MONTAJE SISTEMA VARIO

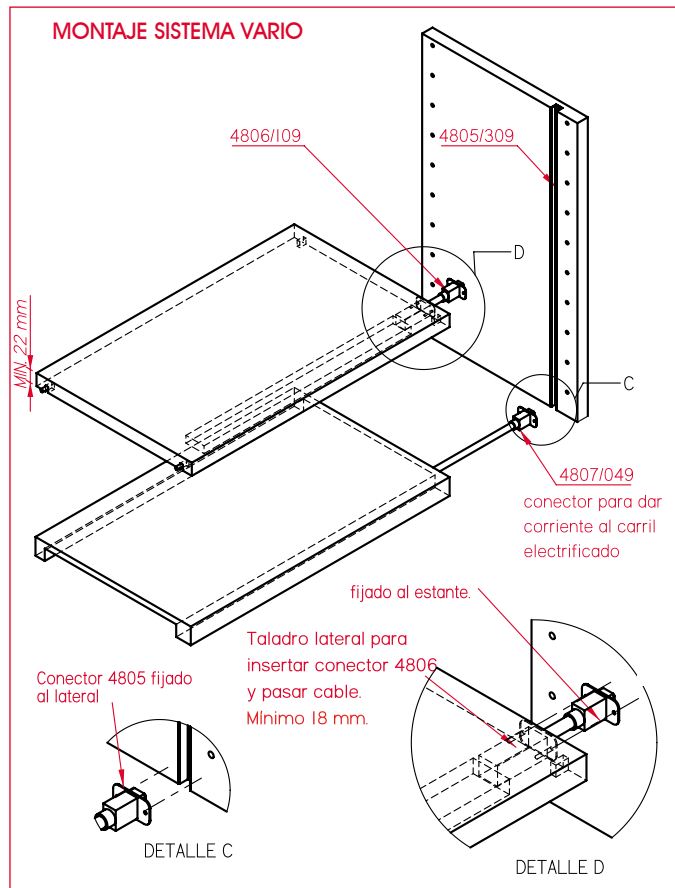

DIMENSIONES REF. 4806 Y 4807

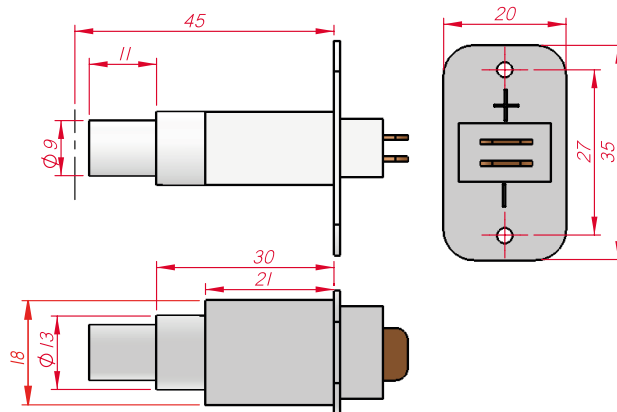

DIMENSIONES REF. 4809

DIMENSIONES REF. 4805

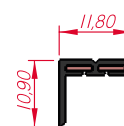
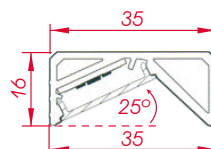



instal.

# KADÍ

SISTEMAS SIN ILUMINACIÓN

## KADÍ CREMALLERAS

KADÍ OMEGA  
KADÍ ALA  
KADÍ CLASSIC  
KADÍ HIERRO EMPOTRABLE  
KADÍ EMPOTRABLE ALUM.  
KADÍ DUO

## KADÍ CREMALLER. COMPONENTES

KADÍ EMPOTRABLE ALUM.  
KADÍ COLUMNA  
KADÍ VÉRTICE  
BOTONES PLÁST. PANELAD.  
KADÍ OMEGA  
KADÍ ALA  
KADÍ DUO  
KADÍ HIERRO EMPOTRABLE

## KADÍ TUBULAR

## KADÍ CARTELAS

### CAPACIDAD DE CARGA

CARTELAS EMPOTRABLE  
CARTELAS "SILUETTE"  
CARTELAS SILUET. INCLIN.  
CABALL. ESTANTE CARTEL.  
CARTELAS "TIBURÓN"  
CARTELAS PASANTES  
CARTEL. PASANT. ACCES.  
ACCESORIOS TUBO OBAL.  
PERROQUETES  
SIST. CUELGUE DE MUEBLES

## PERFIL PARA SIST. KADÍ Y LAMAS

## KADÍ COLUMNAS

VERONA  
BILBO  
MILÁN  
ACCESORIOS - COMPLEM.

## KADÍ PHARMA DUO

SISTEMA  
CORTE DE LA MADERA  
COLUMNAS TROQUELAD.  
COMPONENTES  
PHARMA  
PHARMA DUO

MULTILAMA  
PHARMA + MULTILAMA

## SEPARADORES Y PORTA PRECIOS

SEPARADOR CON  
DISPENSADOR DE PRODUCTO  
PORTA PRECIOS PARA  
VIDRIO Y MADERA

## KADÍ PRIMO 25X25

NUDOS A PRESIÓN  
NUDOS BRIDA  
TAPONES  
TUBO 25X25  
ACCESORIOS

## EJEMPLOS DE MONTAJE

**KADÍ CREMALLERAS**

MEDIDAS CREMALLERAS Y MECANIZACIONES

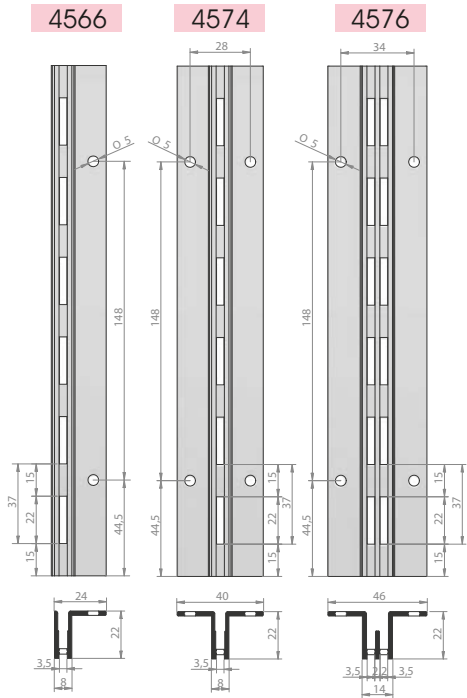

**KADÍ OMEGA**

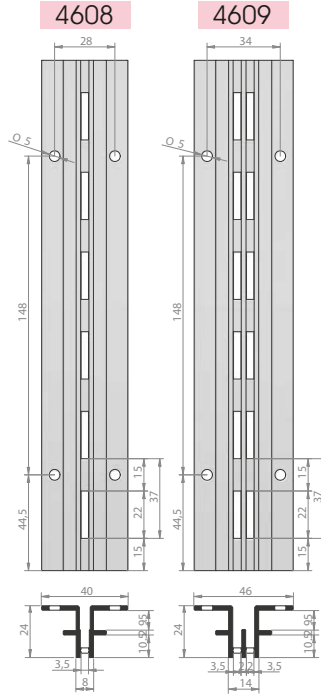

**KADÍ ALA**

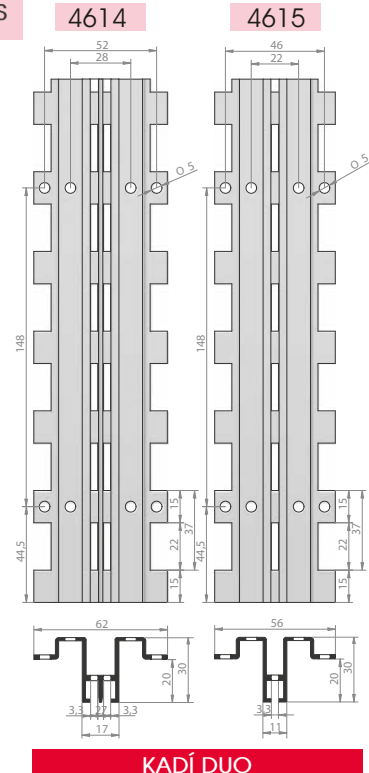

**KADÍ DUO**

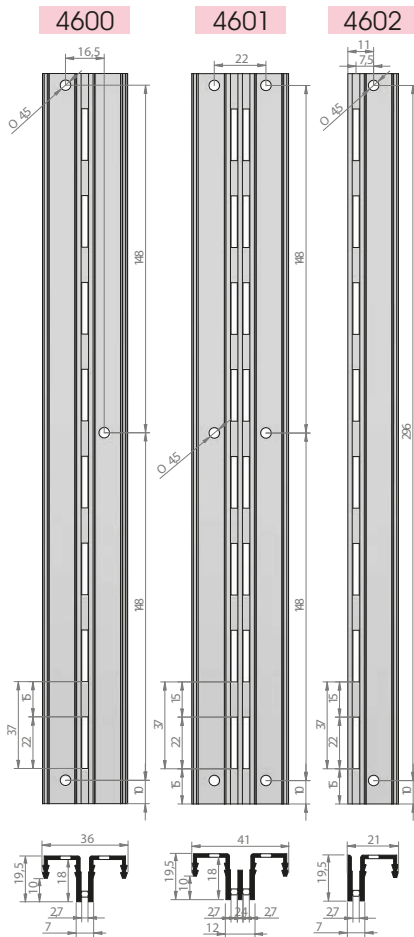

**KADÍ CLASSIC**

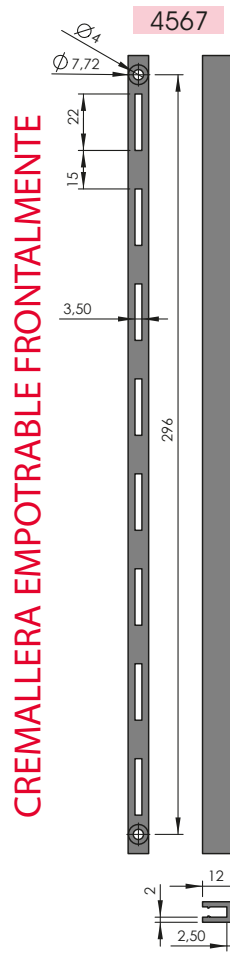

**CREMALLERA EMPOTRABLE FRONTALMENTE**

**KADÍ EMPOTRABLE ALUMINIO**

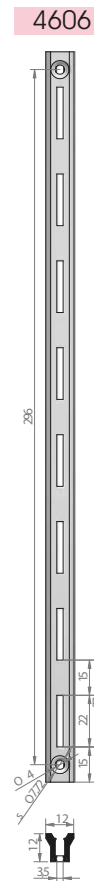

**KADÍ COLUMN**

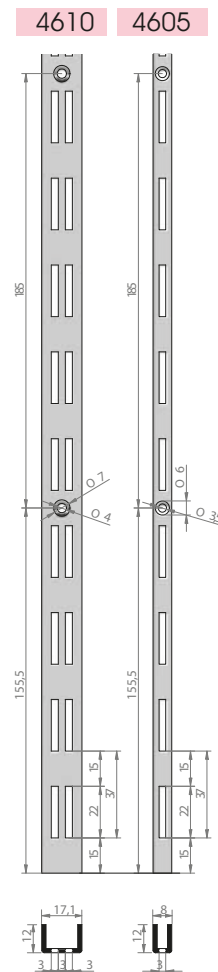

**KADÍ EMPOTRABLE HIERRO**

## KADÍ OMEGA

- 1** **CREMALLERAS FIJADAS A PANEL**  
crémallères fixées à le panneau  
racks fixed to the panel  
cremagliere fissate al pannello

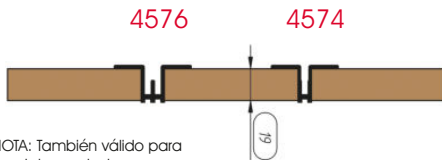
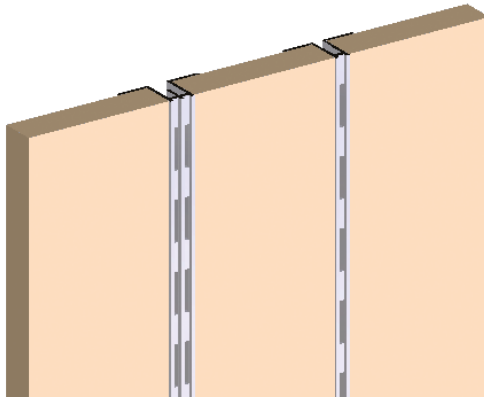

NOTA: También válido para montaje con botones 4780, 4781, 4782.

- 2** **CREMALLERAS EMPOTRADAS CON REMATES 4575 Y 4577**  
crémallères insérées avec cabochones 4575 et 4577  
racks inserted with end-caps 4575 and 4577  
cremagliere inserite da dietro con copristesa 4575 e 4577

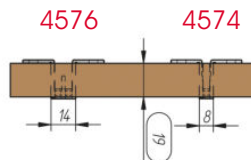
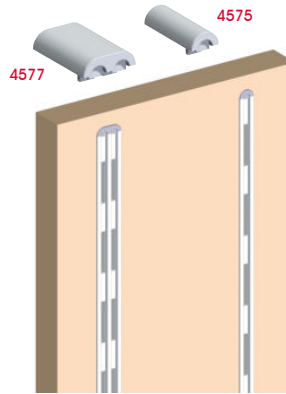

- 3** **CREMALLERAS FIJADAS DIRECTAMENTE A PARED**  
crémallères fixées directement au mur  
racks fixed directly to the wall  
cremagliere fissate direttamente a parete

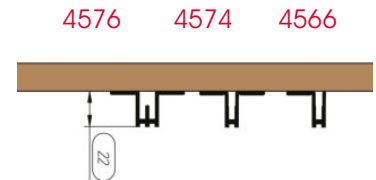
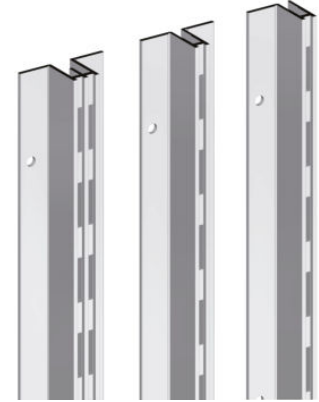

## KADÍ ALA

- 1** **ENSAMBLE MACHIHEMBADO**  
assemblage rainure-langue  
tongue-and-groove joint  
unione a incastro

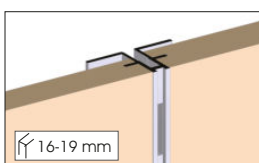
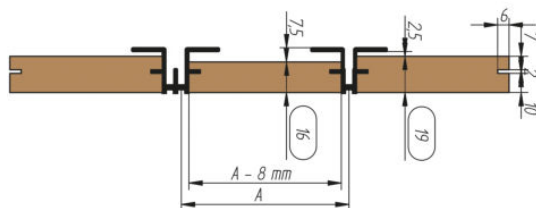
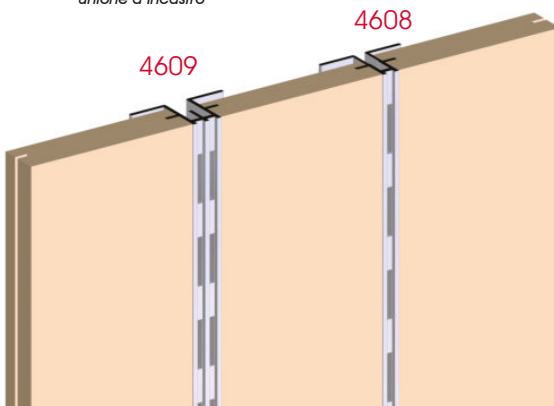

ENSAMBLE CON MADERA DE 16MM O 19MM  
assembler avec du bois de 16 mm ou 19 mm  
assemble with 16mm or 19mm  
assemblare con legno 16mm o 19mm

- 2** **BOTONES 4780, 4781 Y 4782**  
crochetes de maintien 4780, 4781 et 4782  
panel hooks 4780, 4781 and 4782  
fermapannelli 4780, 4781 e 4782

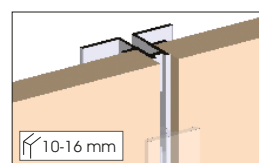
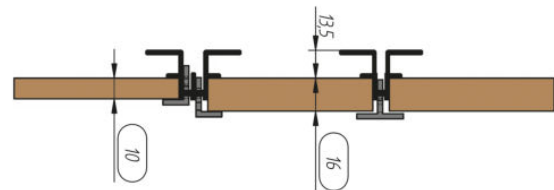
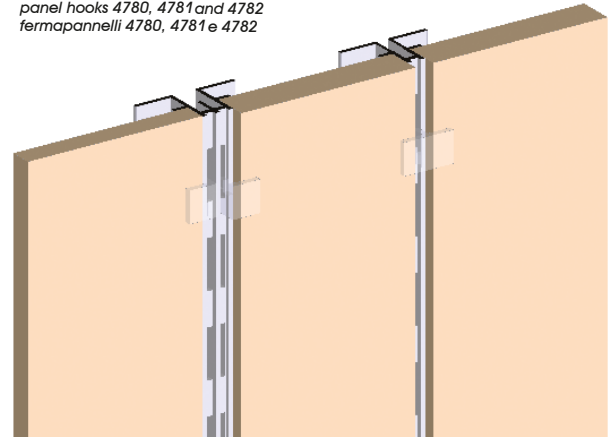

ENSAMBLE CON MADERA DE 10MM O 16MM  
assembler avec du bois de 10 mm ou 16 mm  
assemble with 10mm or 16mm  
assemblare con legno 10mm o 16mm

## KADÍ CLASSIC

PATENTADO - BREVETÉ - PATENTED - BREVETTATO

### EJEMPLOS DE PANELADO CON LAS GUÍAS 4600, 4601 Y 4602

Examples of paneling with racks 4600, 4601 and 4602  
Exemples de panneaux avec des crémaillères 4600, 4601 et 4602  
Esempi di montaggio dei pannelli con i profili cremagliera 4600, 4601 e 4602

**1** CON "GRAPA CLIP" 4607  
avec "GRAPA CLIP" 4607  
with "GRAPA CLIP" 4607  
con "GRAPA CLIP" 4607

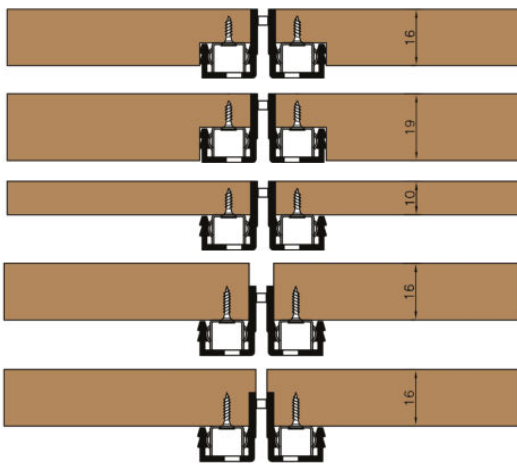

**3** EMPOTRADO SIN GRAPA  
encastré sans clip  
recessed without clip  
incasso senza clip

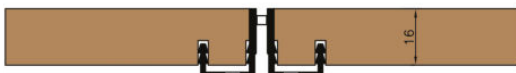

**2** CON BOTONES 4780 - 4781 - 4782  
avec boutons 4780 - 4781 - 4782  
with buttons 4780 - 4781 - 4782  
con bottoni 4780 - 4781 - 4782

4780



4781

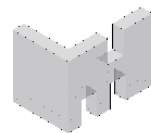

4782

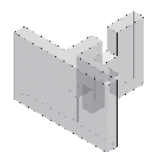

GUÍA VISTA

- con cremalleras 4600, 4601 y 4602  
- panel de 10 mm sin rebajar

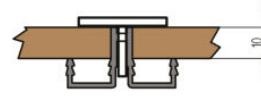

GUÍA OCULTA (6 mm)

- con cremalleras 4600, 4601 y 4602  
- con panel de 16 mm sin rebajar

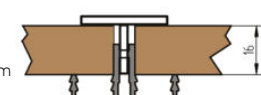

La serie **Classic** y el **casquillo 4699 no admiten** cartelas con los **ganchos del talón pintados**; el troquel tiene una anchura de 2,7 mm y la cartela pintada un espesor de casi 3 mm. **Alu System solo tiene stock de cartelas con el talón sin pintar.** La parte no pintada nunca queda visible desde el exterior. En caso de precisar los talones pintados consultar con departamento comercial.

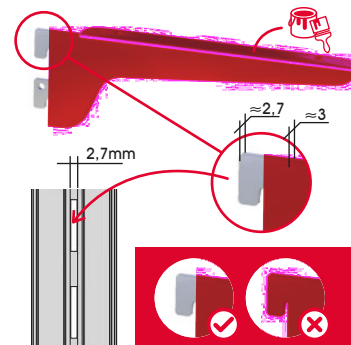

Puede tener algún tipo de oxidación. AluSystem no se hará cargo del posible deterioro.

## KADÍ HIERRO EMPOTRABLES

**1** ENSAMBLE  
assemblage rainure-langette  
tongue-and-groove joint  
unione a incastro

SE ACONSEJAN TORNILLOS AVELLANADOS CON CABEZA PLANA  
Ø 5,5 mm (ej. DIN7997)

Sont recommandés vis à tête fraisée avec tête plate Ø 5,5 mm (ej. DIN7997)  
We recommend countersunk screws with flat head Ø 5,5 mm (ej. DIN7997)  
Si consigilano viti svasate con testa plana Ø 5,5 mm (ej. DIN7997)

**4605 Y 4610**  
COMPATIBLES CON ACCESORIOS SISTEMA KADÍ  
COMPATIBLE AVEC ACCESSOIRES SYSTEME KADÍ  
COMPATIBLE WITH KADÍ SYSTEM FITTINGS  
COMPATIBLE CON ACCESSORI SISTEMA KADÍ

Disponibile también  
en aluminio  
REF 4567

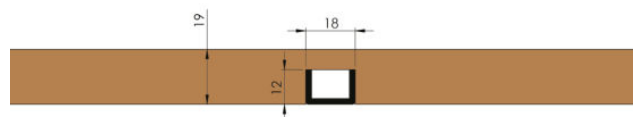
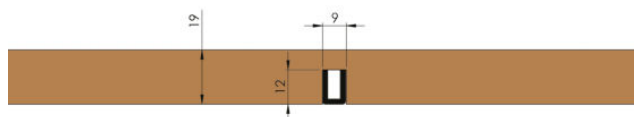
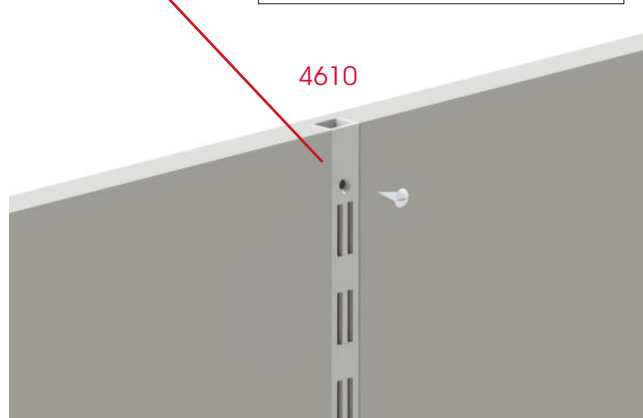
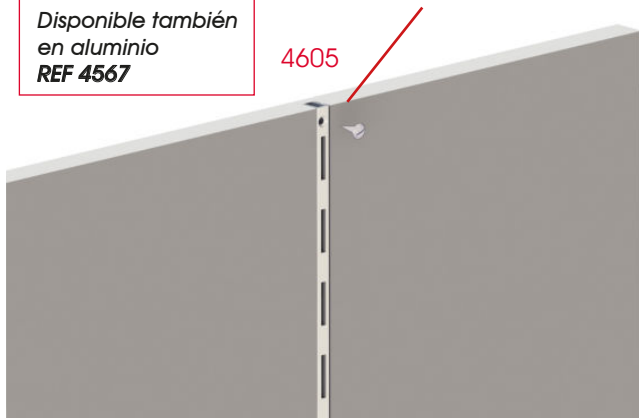



**KADÍ DUO**

KADÍ DUO 4615 Y KADÍ DOBLE DUO 4614 EMPOTRADAS EN PANEL

RACKS DUO 4615 AND DOBLE DUO 4614 EMBEDDED IN THE PANEL  
CRÉMAILLÈRES DUO 4615 AND DOBLE DUO 4614 INTÉGRÉS DANS LE PANNEAU  
PROFILI CREMAGLIERA DUO 4615 E DOBLE DUO 4614 INSERITI NEL PANNELLO

**4615 KADÍ DUO**

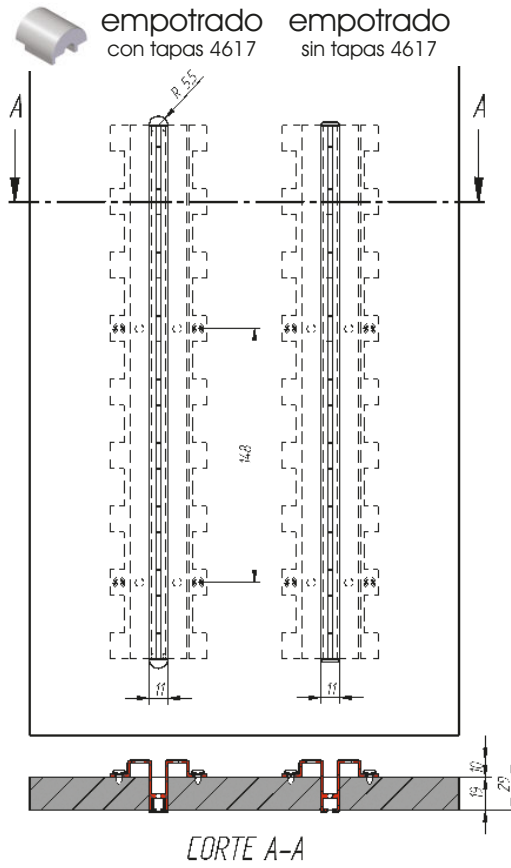
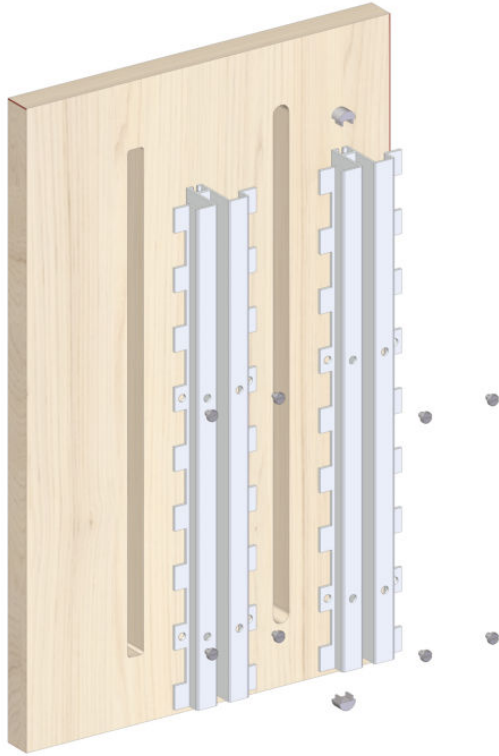

**4614 KADÍ DOBLE DUO**

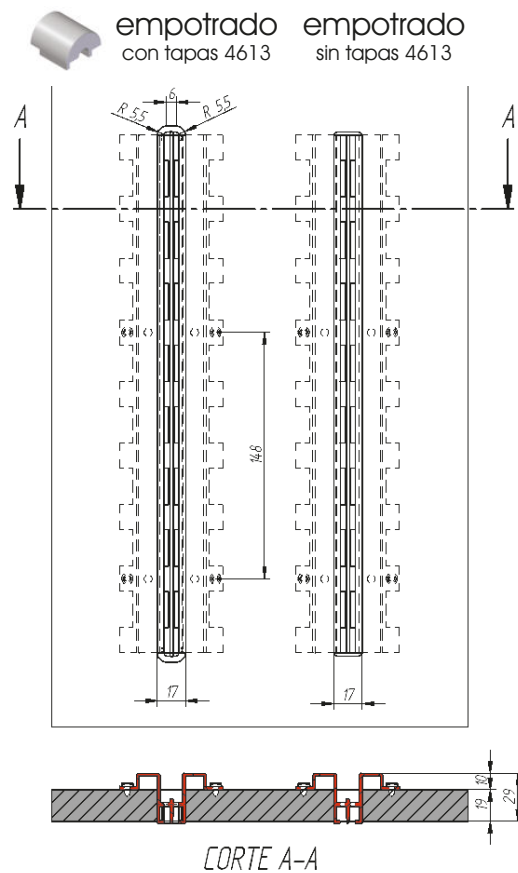

**KADÍ DUO 4615 Y KADÍ DOBLE DUO 4614 PANELES COLGADOS A LAS CREMALLERAS**

RACKS **DUO 4615** AND **DOBLE DUO 4614** PANEL HUNG TO THE RACK  
CRÉMAILLÈRES **DUO 4615** AND **DOBLE DUO 4614** PANNEAUX ACCROCHÉ A LE CRÉMAILLÈRE  
PROFILI CREMAGLIERA **DUO 4615** E **DOBLE DUO 4614** PANNELLO APPESO AL PROFILO

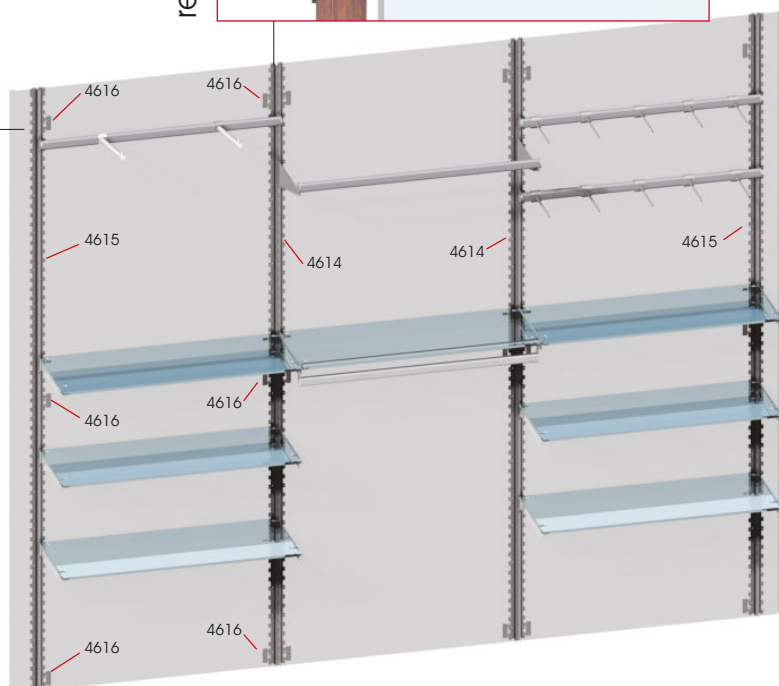
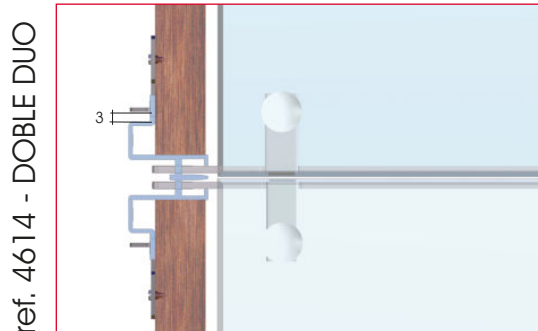

**COLOCACIÓN DE LOS GANCHOS 4616 Y 4635**

- el taladro central del gancho 4616 corresponde al paso de la cremallera: 37 mm.
- utilizar 4 ó 6 ganchos por panel dependiendo de su medida
- la distancia de los ganchos del borde del panel puede variar: se recomienda 36 mm.

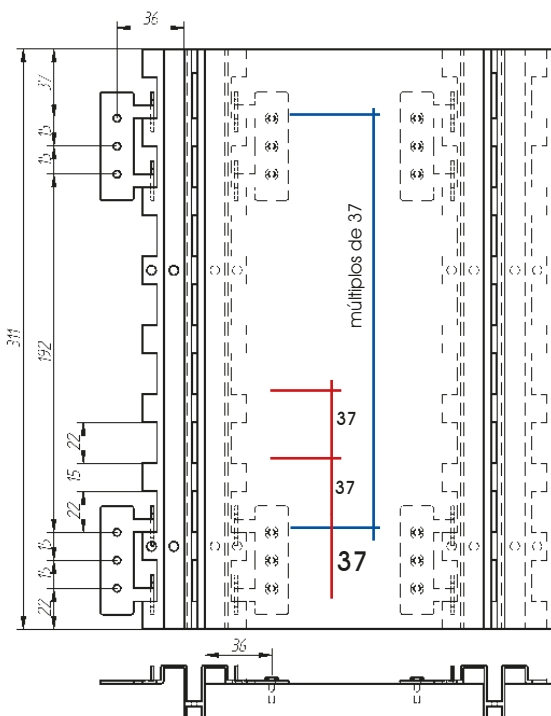
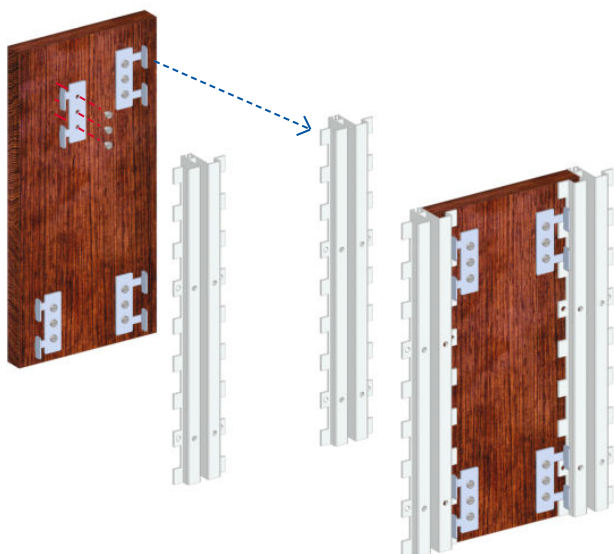

## KADÍ EMPOTRABLE ALUMINIO

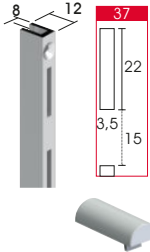

**GUÍA CREMALLERA EMPOTRABLE**  
 GUIDE DE GRILLE ENCASTRÉ  
 RECESSED RACK GUIDE  
 GUIDA RACK AD INCASSO

4567/1.. 5m  
 4567/102 2.5m

REMATE FINAL PARA 4567  
 CABOCHON POUR 4567  
 END-CAP FOR 4567  
 COPRITESTA PER 4567

84567/0..

PL. M ALU. M ALL. NAT	PL. BR ALU. BR ALL. LUC	BLANCO BLANC WHITE	NEGRO NOIR BLACK	COLOR COULEUR COLOR COLORE
01	02	0B	0N	0P

Al	5 m	12x8	€/m
----	-----	------	-----

o		o	o	o
	o			
			o	o



## KADÍ COLUMNNA



**GUÍA PANELABLE 1 CANAL**  
 CRÉMAILLÈRE SIMPLE PERFORATION  
 RACK SINGLE CHANNEL  
 CREMAGLIERA FORATURA SEMPLICE

4600/1.. 5m  
 4600/142 2.5m



PL. BR ALU. BR ALL. LUC	PL. M ALU. M ALL. NAT	BLANCO BLANC WHITE	NEGRO NOIR BLACK	COLOR COULEUR COLOR COLORE
02	01	0B	0N	0P

Al	2.5-5m	19,5x36	€/m
----	--------	---------	-----

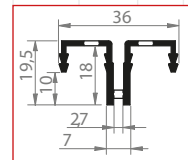

**GUÍA FINAL PANELABLE 1 CANAL**  
 CRÉMAILLÈRE FINALE SIMPLE PERFORATION  
 FINAL RACK SINGLE CHANNEL  
 CREMAGLIERA FINALE FORATURA SEMPLICE

4602/1.. 5m  
 4602/142 2.5m



Al	2.5-5m	19,5x21	€/m
----	--------	---------	-----

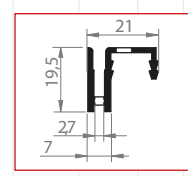

**GUÍA PANELABLE 2 CANALES**  
 CRÉMAILLÈRE DOUBLE PERFORATION  
 RACK DOUBLE CHANNEL  
 CREMAGLIERA FORATURA DOPPIA

4601/1.. 5m  
 4601/142 2.5m

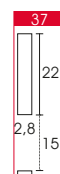

Al	2.5-5m	19,5x41	€/m
----	--------	---------	-----

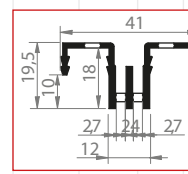

## KADÍ COLUMNNA

GUÍAS-CREMALLERA - CRÉMAILLÈRES  
 RACKS - PROFILI CREMAGLIERA

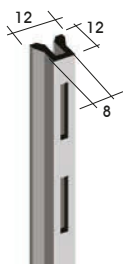

**GUÍA CREMALLERA COLUMNNA**  
 CRÉMAILLÈRE COLONNE  
 RACK FOR COLUMNS  
 CREMAGLIERA COLONNE

4606/1..

PL. M ALU. M ALL. NAT	BLANCO BLANC WHITE	NEGRO NOIR BLACK	COLOR COULEUR COLOR COLORE
01	0B	0N	0P

Al	5 m	12x12	€/m
----	-----	-------	-----

o	o	o	o

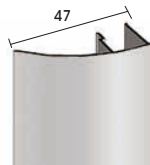

**TAPA DE ALUMINIO**  
 PROFIL À RECOUVREMENT  
 COVER PROFILE  
 PROFILO COPERTINA

\*4603/1..

Al	5 m	19,5x47	€/m
----	-----	---------	-----

∞	4600-4601-4602	
---	----------------	--

*o	*o	*o	*o
----	----	----	----

**TAPA 4603+4600**  
 CABOCHON 4603+4600  
 END-CAP 4603+4600  
 COPRITESTA 4603+4600

\*4604/0..

Fe	∞	4600-4603	€/u
----	---	-----------	-----

INOX SAT  
 INOX SAT  
 S.S.S.  
 INOX SAT

Fe	∞	4600-4601-4602	€/u
----	---	----------------	-----

28

**GRAPA PARA COLGAR PANELES**  
 CROCHET POUR ACCROCHER PANNEAUX  
 HOOK TO HANG WOOD PANELS  
 GANCIO PER APPENDERE PANNELLI

4607/028

## KADÍ \*VÉRTICE

CASQUILLO - INSERT VERTICAL  
 VERTICAL SOCKET - BOCCOLA VERTICALE



**CASQUILLO VERTICAL**  
 INSERT VERTICAL  
 VERTICAL SOCKET  
 BOCCOLA VERTICALE

\*4699/0..

CR. BRILLO CHR. POLI BR. CHR CR. LUC.
32

Zn	90x30 mm	€/u
----	----------	-----

*o	*o	*o	*o
----	----	----	----

## BOTONES PLÁSTICO PARA PANELADO



**BOTÓN IZQUIERDO**  
 CHROCHET GAUCHE  
 DE MAINTIEN  
 LEFT PANEL HOOK  
 FERMAPANNELLO SINISTRO

\*4780/009

PLÁSTICO PLASTIQUE PLASTIC PLASTICA	plas	∞	CLASSIC-OMEGA-ALA	€/u
--	------	---	-------------------	-----

10 - 16 mm
------------

09

\*o

**BOTÓN DERECHA**  
 CHROCHET DROIT DE MAINTIEN  
 RIGHT PANEL HOOK  
 FERMAPANNELLO DESTRO

\*4781/009

\*o

**BOTÓN CENTRAL**  
 CHROCHET DOUBLE DE MAINTIEN  
 DOUBLE PANEL HOOK  
 FERMAPANNELLO DOPPIO

\*4782/009

\*o



## KADÍ TUBULAR

### CARTELAS "TUBULAR" TUBO 30X10

CR. BRILLO	PLÁSTICO	CR. MATE	BLANCO	NEGRO	COLOR
CR. POLI	PLASTIC	CR. M	BLANC	NOR	COULEUR
CR. LUC.	PLASTICA	M. CHR	WHITE	BLACK	COLOR
		CR. OPAC	BANCO	NERO	COLORE
32	09	31	0B	0N	0P

**CARTELA ESTANTE VIDRO**  
SUPPORT TABLETTES VERRE  
GLASS SHELF BRACKET  
MENSOLA RIPIANO VETRO

4583/0.. 28 cm

Fe	8-10 mm	200x292	€/u
----	---------	---------	-----

4647

**CARTELA**  
SUPPORT  
BRACKET  
MENSOLA

4582/0.. 32 cm

Recomendada con cremalleras DUO  
Recommandée avec crémaillères DUO  
Recommended with racks DUO  
Raccomandata con cremagliera DUO

Fe	€/u
∅	2556-358

**VENTOSA**  
TRANSPARENTE  
VENTOUSE  
SUCTION  
VENTOSA

2556/009

Ventosas y pasadores no incluidos  
Ventouses et broches NO INCLUS  
Suctions and pins not included  
Ventose e perni non inclusi

∅	4582-4583-4584
plas	∅ 14

**PASADOR ESTANTE MADERA**  
BROCHES À RESSORT  
PIN WOOD SHELF  
PERNO RIPIANO LEGNO

358/000

∅	4582-4583-4584
Fe	∅ 5x40

**PERROQUET PLANO**  
PENDERIE FRONTAL  
STRAIGHT ARM  
APPENDERIA FRONTALE

4587/0.. 35 cm

Fe	350 mm	€/u
----	--------	-----

**PERROQUET PLANO "T"**  
PENDERIE LATERAL "T"  
LATERAL STRAIGHT ARM "T"  
APPENDERIA LATERALE "T"

4588/0.. 35 cm

Fe	350x600 mm	€/u
----	------------	-----

**PERROQUET PLANO "Z"**  
PENDERIE FRONTAL "Z"  
STRAIGHT ARM "Z"  
APPENDERIA FRONTALE "Z"

4589/0.. 35 cm

Fe	350 mm	€/u
----	--------	-----

**CARTELA + BARRA PENDERIE**  
SUPPORT + BARRE PENDERIE  
BRACKET + HANGING BAR  
MENSOLA + APPENDERIA

4584/0.. 32 cm

Fe	∅ 4585(30x10)	320 mm	€/u
----	---------------	--------	-----

**CARTELA BARRA PENDERIE**  
SUPPORT BARRE PENDERIE  
BRACKET HANGING BAR  
MENSOLA APPENDERIA

4590/..

Ventosas y pasadores no incluidos  
Ventouses et broches NO INCLUS  
Suctions and pins not included  
Ventose e perni non inclusi

Fe	∅ 4585(30x10)	320 mm	€/u
----	---------------	--------	-----

**CARTELA BARRA ACCESORIOS**  
SUPPORT BARRE ACCESSOIRES  
BRACKET FOR ACCESSORIES ROD  
MENSOLA TUBO PORTA-ACCESSORI

4591/0..

Fe	∅ 4585(30x10)	60 mm	€/u
----	---------------	-------	-----

**CARTELA BARRA PENDERIE**  
SUPPORT BARRE PENDERIE  
BRACKET HANGING BAR  
MENSOLA APPENDERIA

4584/0.. 32 cm

Fe	∅ 4585(30x10)	320 mm	€/u
----	---------------	--------	-----

**CARTELA BARRA PENDERIE**  
SUPPORT BARRE PENDERIE  
BRACKET HANGING BAR  
MENSOLA APPENDERIA

4590/..

Ventosas y pasadores no incluidos  
Ventouses et broches NO INCLUS  
Suctions and pins not included  
Ventose e perni non inclusi

Fe	∅ 4585(30x10)	320 mm	€/u
----	---------------	--------	-----

**CARTELA BARRA ACCESORIOS**  
SUPPORT BARRE ACCESSOIRES  
BRACKET FOR ACCESSORIES ROD  
MENSOLA TUBO PORTA-ACCESSORI

4591/0..

Fe	∅ 4585(30x10)	60 mm	€/u
----	---------------	-------	-----

### CARTELAS "PLANAS" TUBO 30X10 HIERRO

CR. BRILLO	PL. M	CR. MATE	BLANCO	NEGRO	COLOR
CR. POLI	ALU. M	CR. M	BLANC	NOR	COULEUR
CR. LUC.	ALU. M	M. CHR	WHITE	BLACK	COLOR
	ALL. NAT	CR. OPAC	BANCO	NERO	COLORE
32	01	31	0B	0N	0P

**CARTELA BARRA PENDERIE**  
SUPPORT BARRE PENDERIE  
BRACKET HANGING BAR  
MENSOLA APPENDERIA

30x10 mm (4585)

Fe	∅ 4585(30x10)	320 mm	€/u
----	---------------	--------	-----

4648/0.. derecha  
droite/right/destra

4647/0.. izquierda  
gauche/left/sinistra

**CARTELA BARRA ACCESORIOS**  
SUPPORT BARRE ACCESSOIRES  
BRACKET FOR ACCESSORIES ROD  
MENSOLA TUBO PORTA-ACCESSORI

Fe	∅ 4585(30x10)	€/u
----	---------------	-----

4580/0.. derecha  
droite/right/destra

4581/0.. izquierda  
gauche/left/sinistra

**TUBO RECTANGULAR**  
TUBE RECTANGULAIRE  
RECTANGULAR TUBE  
TUBO RETTANGOLARE

Inx	6 m	30x10x1,5	€/m
-----	-----	-----------	-----

4260/122

**TAPA FINAL CON TOPE**  
EMBOUT AVEC RETENTION  
END-CAP WITH STOP  
COPRITESTA + RETENZIONE

Fe	∅ 4585	40x10 mm	€/u
----	--------	----------	-----

4586/0..

### CARTELAS "PLANAS" TUBO 30X10 ALUMINIO

**SET DE 2 CARTELAS**  
LOT DE 2 SUPPORTS  
SET OF 2 BRACKETS  
SET DI 2 MENSOLE

4866/0..

Fe	?? mm	∅ 4900	€/u
----	-------	--------	-----

**SET DE 2 CARTELAS**  
LOT DE 2 SUPPORTS  
SET OF 2 BRACKETS  
SET DI 2 MENSOLE

4868/0..

Fe	?? mm	∅ 4900	€/u
----	-------	--------	-----

**TUBO RECTANGULAR 30X10MM**  
TUBE RECTANGULAIRE 30X10  
RECTANGULAR TUBE 30X10  
TUBO RETTANGOLARE 30X10

Al	6 m	30x10	€/m
----	-----	-------	-----

4900/10.

**TAPA PARA TUBO 30X10MM**  
CAPUCHON DE TUBE 30X10  
TUBE CAP 30X10  
TAPPO DEL TUBO 30X10

Fe	92 mm	∅ 4900	€/u
----	-------	--------	-----

4904/00.

### ACCESORIOS COMUNES 30X10

**PERROQUET PLANO**  
PENDERIE FRONTAL  
STRAIGHT ARM  
APPENDERIA FRONTALE

4592/0..

Fe	∅ 4585	350 mm	€/u
----	--------	--------	-----

**PERROQUET INCLINADO**  
PERROQUET INCLINEE  
SLOPING ARM  
APPENDERIA INCLINADA

4593/0..

Fe	∅ 4585	400 mm	€/u
----	--------	--------	-----

**GANCHO**  
CROCHET  
HOOK  
BARRETTA

5588/0.. 15 cm

4594/0.. 20 cm

5589/0.. 25 cm

5590/0.. 30 cm

Fe	∅ 4585	€/u
----	--------	-----

**GANCHO PORTAPRECIO**  
CROCHET PORTAPRIX  
HOOK LABEL-HOLDER  
BARRETTA PORTAPREZZO

5591/0.. 15 cm

5592/0.. 20 cm

4597/0.. 25 cm

5593/0.. 30 cm

Fe	∅ 4585-382	€/u
----	------------	-----

**PORTAPRECIO**  
PORTAPRIX  
LABELHOLDER  
PORTAPREZZO

382/009

plas	40x50 mm	€/u
------	----------	-----

PLÁSTICO  
PLASTIC  
PLASTICA  
09

KADÍ CARTELAS

CARTELAS ESPECIALES "VIDRIO"

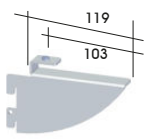

**CARTELA ESTANTE VIDRIO**  
SUPPORT TABLETTE VERRE  
GLASS SHELF BRACKET  
MENSOLA RIPIANO VETRO  
**4645/0..** derecha  
droite/right/destra  
**4646/0..** izquierda  
gauche/left/sinistra

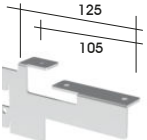

**CARTELA ESTANTE VIDRIO**  
SUPPORT TABLETTE VERRE  
GLASS SHELF BRACKET  
MENSOLA RIPIANO VETRO  
**4622/0..** derecha  
droite/right/destra  
**4623/0..** izquierda  
gauche/left/sinistra

CARTELAS ESPECIALES PARA PHARMA, CREMALLERA DUO, Y ELECTRIFICADO. (APTO PARA TODOS LOS SISTEMAS KADÍ)



**CARTELA SUPPORT BRACKET MENSOLA**  
**5844/...** derecha  
droite/right/destra  
**5845/...** izquierda  
gauche/left/sinistra

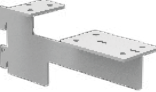

**5846/...** doble  
double/double/doppio



SE RECOMIENDA ESTANTE DE VIDRIO TEMPLADO DE 30CM DE PROFUNDIDAD

**CARTELA FINAL ANTIVUELCO**  
SUPPORT FINAL ANTIBASCULAMENT  
FINAL BRACKET ANTITIPPING  
MENSOLA FINALE ANTIRIBALTAMENTO  
**\*4618/3..**



SE RECOMIENDA ESTANTE DE VIDRIO TEMPLADO DE 30CM DE PROFUNDIDAD

**CARTELA INTERMEDIA ANTIVUELCO**  
SUPPORT INTERMÉDIAIRE ANTIBASCULAMENT  
INTERMEDIATE BRACKET ANTITIPPING  
MENSOLA INTERMEDIA ANTIRIBALTAMENTO  
**\*4619/3..**

CARTELAS ESPECIALES "MADERA"

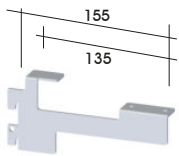

**CARTELA ESTANTE MADERA**  
SUPPORT TABLETTE BOIS  
WOOD SHELF BRACKET  
MENSOLA RIPIANO LEGNO  
**4620/0..** derecha  
droite/right/destra  
**4621/0..** izquierda  
gauche/left/sinistra

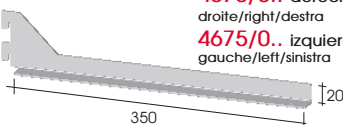

**CARTELA ESTANTE MADERA**  
SUPPORT TABLETTE BOIS  
WOOD SHELF BRACKET  
MENSOLA RIPIANO LEGNO  
**4676/0..** derecha  
droite/right/destra  
**4675/0..** izquierda  
gauche/left/sinistra

CR. BRILLO	INOX SAT	SAT	CR. MATE	BLANCO	NEGRO	COLOR
CR. POLI	INOX SAT	S.S.S.	CR. M	BLANC	NOIR	COULEUR
CR. ILLUC.	INOX SAT	INOX SAT	CR. OPAC	WHITE	BLACK	COLOR
32	28	31	0B	0N	0P	

Fe	8-10 mm	119 mm	€/u

Fe	8-10 mm	125 mm	€/u

Fe	8-10 mm	14,9 cm	€/u
----	---------	---------	-----

Fe	8 mm	€/u
----	------	-----

Fe	8 mm	€/u
----	------	-----

Fe	19 mm	155 mm	€/u
----	-------	--------	-----

Fe	19 mm	350 mm	€/u
----	-------	--------	-----



La profundidad de estante recomendado para las cartelas suspendidas de la gama "CARTELAS ESPECIALES VIDRIO" es de 25-30 cm max.

La profundidad del estante interfiere directamente en la capacidad y resistencia de aguante de las mismas cartelas y de todo el sistema.

"SILUETTE" PLEGADA PARA VIDRIO Y MADERA



**CARTELA SUPPORT BRACKET MENSOLA**  
**4692/0..** derecha  
droite/right/destra  
**4691/0..** izquierda  
gauche/left/sinistra



**4694/0..** derecha  
droite/right/destra  
**4693/0..** izquierda  
gauche/left/sinistra



**VENTOSA TRANSPARENTE**  
VENTOUSE  
SUCTION  
VENTOSA  
**2556/009**

Fe	23 cm	€/u
----	-------	-----

Fe	28 cm	€/u
----	-------	-----

∞	4691-4692-4693-4694	€/u
	plac	∅ 14

CARTELAS "GRANDES PESOS" PARA VIDRIO Y MADERA



**CARTELA GRANDES PESOS**  
SUPPORT GRAN POND  
BRACKET HEAVY WEIGHT  
MENSOLA GRANDI PESI  
**4652/0..** derecha  
droite/right/destra  
**4653/0..** izquierda  
gauche/left/sinistra

Fe	35 cm	€/u
----	-------	-----

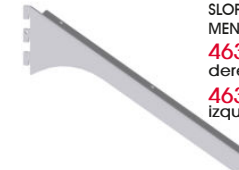

**CARTELA INCLINADA 30°**  
SUPPORT INCLINÉE 30°  
SLOPING BRACKET 30°  
MENSOLA INCLINATA 30°  
**4632/0..** derecha  
droite/right/destra  
**4633/0..** izquierda  
gauche/left/sinistra

Fe	38 cm	€/u
----	-------	-----



**CARTELA GRANDES PESOS**  
SUPPORT GRAN POND  
BRACKET HEAVY WEIGHT  
MENSOLA GRANDI PESI  
**4654/0..** derecha  
droite/right/destra  
**4655/0..** izquierda  
gauche/left/sinistra

Fe	42 cm	€/u
----	-------	-----



**CARTELA GRANDES PESOS**  
SUPPORT GRAN POND  
BRACKET HEAVY WEIGHT  
MENSOLA GRANDI PESI  
**4656/0..** derecha  
droite/right/destra  
**4657/0..** izquierda  
gauche/left/sinistra

Fe	52 cm	€/u
----	-------	-----



**VENTOSA TRANSPARENTE**  
VENTOUSE  
SUCTION  
VENTOSA  
**2556/009**

∞	4652-4653-4654-4655	€/u
	plac	∅ 14



**CARTELA SUPPORT BRACKET MENSOLA**  
**\*4650/0..** derecha  
droite/right/destra  
**\*4651/0..** izquierda  
gauche/left/sinistra

Fe	30 cm	€/u
----	-------	-----

## CAPACIDAD DE CARGA

Loading capacities - Capacités de chargement - Carichi massimi

FONDO ESTANTE, DEEPH SHELF, FOND DE TABLETTE, PROFONDITA RIPIANO

### PESOS ORIENTATIVOS CARTELAS

hasta 20 cm hasta 25 cm hasta 30 cm hasta 35 cm hasta 40 cm hasta 50 cm

GANCHOS CARTELAS  
HOOKS BRACKETS  
CROCHET SUPPORTES  
GANCI MENSOLE

**2 ganchos**  
Cartelas empotrables, siluette y tubulares.

**3 ganchos**  
Cartelas empotrables, siluette y tubulares.

**3 ganchos con pliege**  
Cartelas para grandes pesos.

**2 ganchos con vidrio suspendido o con perfil tipo 362**

90 kg/est.

80 kg/est.

70 kg/est.

60 kg/est.

80 kg/est.

70 kg/est.

60 kg/est.

100 kg/est.

100 kg/est.

90 kg/est.

30 kg/est.

20 kg/est.

ALUSYSTEM recomienda el uso de vidrio templado para los estantes.

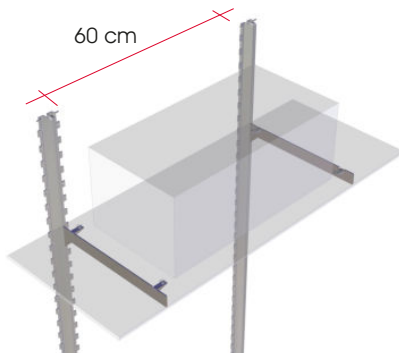

### 1 estante

1SELF 2 BRACKETS

1 TABLETTE 2 SUPPORTES

1 RIPIANO 2 MENSOLE

- peso distribuido encima del estante  
- cremallera fijada a la pared (u otro soporte) en todos los puntos  
- Pladur: **¡ATENCIÓN!** en caso de grandes pesos reforzar la pared o anclar a los montantes estructurales

- Weight distributed over the shelf  
- Rack fixed to the wall (or other support) at all points  
- Plasterboard: **ATTENTION!** for large weights to strengthen the wall metal structure and to anchor the racks to structural frames

- Poids réparti sur le tablette  
- Crémallière fixée à la paroi (ou autre support) à tous les points  
- Plaques de plâtre: **ATTENTION!** pour les grands poids de renforcer les montants structurelles du mur et fixée les crémaillères à la structure

- peso distribuito uniformemente sul ripiano  
- profili cremagliera fissati alla parete (o ad altri tipi di supporto) in tutti i punti  
Cartongesso: **ATTENZIONE!** in caso di grandi pesi, rinforzare le parete e fissare i profili cremagliera ai montanti strutturali

- **¡ATENCIÓN!** peso soportado por la cartela intermedia = suma del peso de los dos estantes dividido por 2

- **ATTENTION!** weight supported by intermediate gusset = sum of the weight of the two shelves divided by 2

- **ATTENTION!** poids supporté par intermédiaire gousset = somme des poids des deux plateaux divisés par 2

- **ATTENZIONE!** peso sopportato dalla mensola intermedia = somma del peso dei due ripiani diviso per 2

La resistencia de la cartela está determinada por:

1. el número de enganches a la cremallera (2 o 3),
2. la forma de la cartela (plegada más resistente)
3. el largo de la cartela (más corta más peso)

Cuanto más el baricentro del peso se coloca lejos de las guías, mayor es el esfuerzo que tiene que soportar la cartela.

Ejemplo: un peso de 20 kg a 30 cms de la cremallera corresponde a un peso de 40 kg a 15 cms o de 60 kg a 10 cms.

The strength of the bracket is determined by:

1. the number of hooks to the rack (2 or 3),
2. the shape of the bracket (folded more resistant)
3. the length of the bracket (shorter heavier)

The more the centroid of the weight is placed far from the guidelines, the greater the effort you have to put the bracket.

Example: the ability to withstand a weight of 20 kg to 30 cms of the slotted rack corresponds to a weight of 40 kg to 15 cms or 60 kg to 10 cms.

La force du support est déterminé par:

1. le nombre de crochets de la crémaillère (2 ou 3),
2. la forme de la console (plié plus résistants)
3. la longueur de la console (plus lourd plus courte)

Le plus le centre de gravité de la masse est placée loin de les crémaillères, plus les efforts que doit supporter le support.

Exemple: la capacité à résister le poids de 20 kg à 30 cm de la crémaillère correspond à un poids de 40 kg à 15 cm ou de 60 kg à 10 cm.

La resistenza delle mensole è determinata da:

1. numero di ganchi per il profilo-cremagliera
2. forma delle mensole (le mensole piegate sono più resistenti)
3. la lunghezza delle mensole (più corte più resistenti)

Quanto maggiore è la distanza del baricentro del carico dai profili cremagliera tanto maggiore è lo sforzo che le mensole devono sopportare.

Esempio: la capacità di sopportare un peso di 20 kg a 30 cm dal profilo cremagliera corrisponde a 40 kg a 15 cm o di 60 kg a 10 cm.

### 2 estantes + cartela intermedia

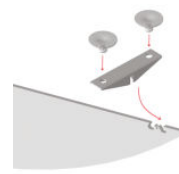

### PESOS ORIENTATIVOS CREMALLERAS

Cremalleras DUO, Elektric, Omega, Ala y CR (4600 y 4601):

Con un peso de 100 kg repartido entre dos cremalleras no se han observado deformaciones importantes en las mismas.

Con un peso de 120 kg se ha detectado una deformación de 2/3° de la mismas. No se han detectado roctura con más de 200 kg.

DUO, Elektric, Omega, Ala and CR (4600 and 4601) slotted racks:

With a weight of 100 kg divided between two racks no significant deformation was observed.

With a weight of 120 kg has been detected deformation 2/3°.

No breakage detected more than 200 kg.

Crémaillères DUO, Elektric, Omega, Ala et CR (4600 et 4601):

Avec un poids de 100 kg divisé entre deux racks pas de déformation significative n'a été observée.

Avec un poids de 120 kg a été détectée déformation de 3.2°.

Pas de rupture détecté plus de 200 kg.

Profili cremagliera DUO, Elektric, Omega, Ala e CR (4600 e 4601):

Con un carico di 100 kg ripartito fra due profili cremagliera non si osservano deformazioni importanti.

Con 120 kg si è registrata un'inclinazione del ripiano di 2/3°

Con più di 200 kg non si è arrivati alla rottura dei profili cremagliera.

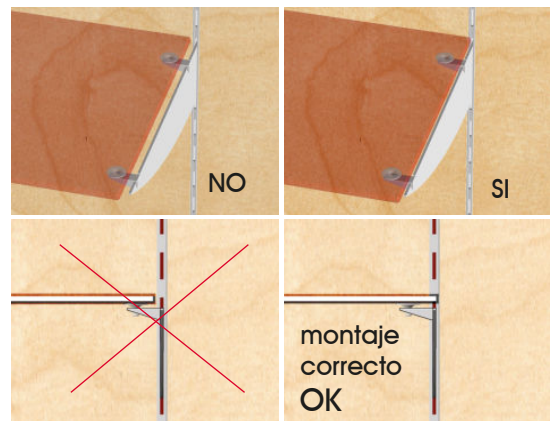

CARTELAS "EMPOTRABLE"

	CR. BRILLO C.R. POLI BR. CHR CR. LUC.	INOX S.S.S. INOX	SAT SAT SAT	CR. MATE C.R. M M. CHR CR. OPAC	BLANCO WHITE BIANCO	NEGRO BLACK NERO	COLOR COULEUR COLORE			
	32	28	31	OB	ON	OP				
<b>CARTELA SUPPORT BRACKET MENSOLA</b>										
4671								Fe	∞ 4700-4701	€/u
4672										
4673										
<b>CARTELA + BARRA PENDERIE SUPPORT + BARRE PENDERIE BRACKET + HANGING BAR MENSOLA + APPENDERIA</b>										
5790								Fe	∞ 4700-4701-4547 (36x18)	€/u
									32 cm	
4624										
<b>CARGA LIGERA max. 30KG</b>										
<b>CARTELA SUPPORT BRACKET MENSOLA</b>										
4643								Fe	€/u	

CARTELA EMPOTRABLE EN ESTANTE DE MADERA

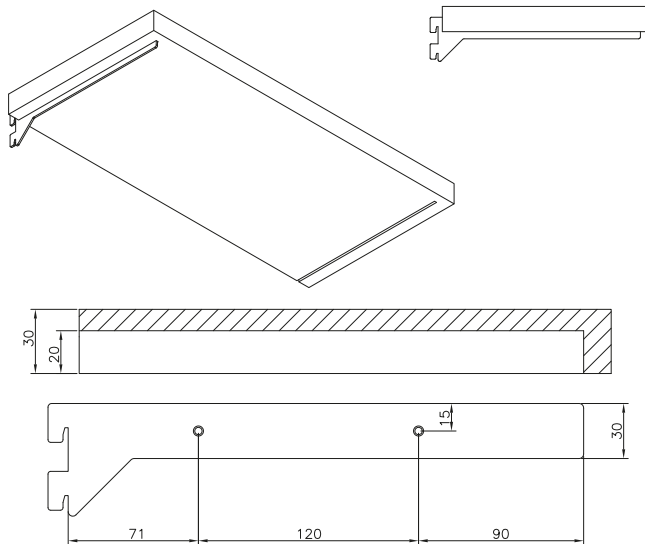

CARTELA "SILUETTE" SUPPORTS "SILUETTE" "SILUETTE" BRACKETS SERIES MENSOLE "SILUETTE"

estante madera = tornillos  
tablette en bois = vis  
wood shelf = screws  
ripiano di legno = viti

**CARTELA FINAL 4700**  
La aleta final 4700 sirven para mano derecha y mano izquierda  
**SUPPORT FINAL 4700**  
Le cavalier final 4700 peut être utilisé pour la main gauche et la main droite.  
**FINAL BRACKET 4700**  
The saddles 4700 can be used for left hand and right hand  
**MENSOLA FINALE 4700**  
Il Cavaliere 4700 si può usare a mano destra y a mano sinistra

estante vidrio = ventosas  
tablette en bois = ventouses  
wood shelf = suctions  
ripiano di legno = ventose



CARTELAS "SILUETTE"

	CR. BRILLO C.R. POLI BR. CHR CR. LUC.	PLÁSTICO PLASTIC PLASTICA	BLANCO WHITE BIANCO	NEGRO BLACK NERO	COLOR COULEUR COLORE					
	32	09	OB	ON	OP					
<b>CARTELA SUPPORT BRACKET MENSOLA</b>										
4680								Fe	∞ 4700-4701	€/u
4681										
4682										
4683										
4684										

CARTELAS "SILUETTE" INCLINADA

	CR. BRILLO C.R. POLI BR. CHR CR. LUC.	PLÁSTICO PLASTIC PLASTICA	BLANCO WHITE BIANCO	NEGRO BLACK NERO	COLOR COULEUR COLORE					
	32	09	OB	ON	OP					
<b>CARTELA INCLINADA 30° SUPPORT INCLINÉE 30° SLOPPING BRACKET 30° MENSOLA INCLINATA 30°</b>										
4696								Fe	∞ 4700-4701	€/u

CABALLETES ESTANTES PARA CARTELAS

	CR. BRILLO C.R. POLI BR. CHR CR. LUC.	PLÁSTICO PLASTIC PLASTICA	BLANCO WHITE BIANCO	NEGRO BLACK NERO	COLOR COULEUR COLORE					
	32	09	OB	ON	OP					
<b>ALETA FINAL CAVALIER FINAL FINAL SADDLES CAVALIERE FINALE</b>										
4700/0..								Fe	∞ 4702-319-2556	€/u
<b>ALETA INTERMEDIA CAVALIER DOUBLE BOUBLE SADDLES CAVALIERE DOPPIO</b>										
4701/0..								Fe	∞ 4702-319-2556	€/u
<b>APOYO APPUI SUPPORT APPOGGIO</b>										
4702/009								plas	∅9 ∞ 4700-4701	€/u
<b>VENTOSA VENTOUSE SUCTION VENTOSA</b>										
319/009								plas	∅20 ∞ 4700-4701	€/u
<b>VENTOSA VENTOUSE SUCTION VENTOSA</b>										
2556/009								plas	∅14 ∞ 4700-4701	€/u

CARTELAS "TIBURÓN"

	CR. BRILLO C.R. POLI BR. CHR CR. LUC.	PLÁSTICO PLASTIC PLASTICA	BLANCO WHITE BIANCO	NEGRO BLACK NERO	COLOR COULEUR COLORE					
	32	09	OB	ON	OP					
<b>CARTELA SUPPORT BRACKET MENSOLA</b>										
4662										
<b>CARTELA + BARRA PENDERIE SUPPORT + BARRE PENDERIE BRACKET + HANGING BAR MENSOLA + APPENDERIA</b>										
*4665/032 final								Fe	33 cm	€/u
*4666/032 central									∞ 4700-4701-4547 (36x18)	

CARTELA INTERMEDIA

La aleta doble 4701 permite compartir 2 estantes con una sola cartela y una cremallera simple de un sólo troquel.  
**SUPPORT INTERMEDIAIRE**  
Le cavalier double 4701 vous permettent de partager 2 étagères avec un seul support et une crémaillère simple perforation.  
**INTERMEDIATE BRACKET**  
The double saddles allows you to share 2 shelves with a single bracket and a single slot rack.  
**MENSOLA INTERMEDIA**  
Il cavaliere doppio 4701 permette l'uso di 2 ripiani con una sola mensola e con una cremagliera con foratura semplice.

## CARTELA PASANTE BARRA COLGADORA (36X18)

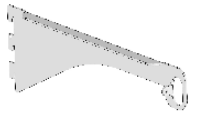

**CARTELA BARRA PENDERIE**  
SUPPORT BARRE PENDERIE  
BRACKET HANGING BAR  
MENSOLA APPENDERIA

**5628/0..** derecha  
droite/right/destra  
**5629/0..** izquierda  
gauche/left/sinistra



CARGA MEDIA - BAJA

**\*4628/0..** derecha  
droite/right/destra  
**\*4629/0..** izquierda  
gauche/left/sinistra

	CR. BRILLO CHR. POLI BR. CHR. CR. LUC.	CR. MATE CHR. M M. CHR. CR. OPAC	BLANCO BLANC WHITE BIANCO	NEGRO NOR BLACK NERO	COLOR COULEUR COLOR COLORE
	32	31	OB	ON	OP

Fe	32 cm	∞	4547 (36x18)	€/u
----	-------	---	--------------	-----

o				
---	--	--	--	--

o				
---	--	--	--	--

o				
---	--	--	--	--

*o	*o	*o	*o	*o
----	----	----	----	----

*o	*o	*o	*o	*o
----	----	----	----	----

## CARTELA FINAL BARRA COLGADORA (36X18)



CARGA MEDIA - ALTA

**CARTELA BARRA CUELGE**  
SUPPORT DE BARRE DE  
SUSPENSION  
HANGING BAR BRACKET  
STAFFA PER BARRA SOSPESA

**4790/0..** derecha  
droite/right/destra  
**4791/0..** izquierda  
gauche/left/sinistra



CARGA MEDIA - ALTA

**CARTELA BARRA CUELGE**  
SUPPORT DE BARRE DE  
SUSPENSION  
HANGING BAR BRACKET  
STAFFA PER BARRA SOSPESA

**4799/0..** intermedia  
inter./inter./inter.

Fe	32 cm	∞	4547 (36x18)	€/u
----	-------	---	--------------	-----

o	*o	o	o	o
---	----	---	---	---

o	*o	o	o	o
---	----	---	---	---

o	*o	o	o	o
---	----	---	---	---

Fe	32 cm	∞	4547 (36x18)	€/u
----	-------	---	--------------	-----

o	*o	o	o	o
---	----	---	---	---

o	*o	o	o	o
---	----	---	---	---

## CARTELA PASANTE BARRA ACCESORIOS (36X18)



**CARTELA BARRA ACCESORIOS**  
SUPPORT BARRE ACCESORIOS  
BRACKET FOR ACCESSORIES ROD  
MENSOLA TUBO PORTA-ACCESSORI

**4626/0..**

**CARTELA BARRA ACCESORIOS**  
SUPPORT BARRE ACCESORIOS  
BRACKET FOR ACCESSORIES ROD  
MENSOLA TUBO PORTA-ACCESSORI

**4627/0..**

TUBO PASANTE  
TUBE PASSANTE  
THROUGH TUBE  
TUBO PASSANTE

4722 / 4721



	CR. BRILLO CHR. POLI BR. CHR. CR. LUC.	CR. MATE CHR. M M. CHR. CR. OPAC	BLANCO BLANC WHITE BIANCO	NEGRO NOR BLACK NERO	COLOR COULEUR COLOR COLORE
	32	31	OB	ON	OP

Fe	∞	4547(36x18)	43 mm	€/u
----	---	-------------	-------	-----

o	*o	o	o	o
---	----	---	---	---

Fe	∞	4547(36x18)	67 mm	€/u
----	---	-------------	-------	-----

o				
---	--	--	--	--

o				
---	--	--	--	--

o				
---	--	--	--	--

o				
---	--	--	--	--

o				
---	--	--	--	--

o				
---	--	--	--	--

## CARTELA FINAL BARRA ACCESORIOS (36X18)



**CARTELA BARRA ACCESORIOS**  
SUPPORT BARRE ACCESORIOS  
BRACKET FOR ACCESSORIES ROD  
MENSOLA TUBO PORTA-ACCESSORI

**4716/0..** derecha  
droite/right/destra  
**4717/0..** izquierda  
gauche/left/sinistra

**CARTELA BARRA ACCESORIOS**  
SUPPORT BARRE ACCESORIOS  
BRACKET FOR ACCESSORIES ROD  
MENSOLA TUBO PORTA-ACCESSORI

**4715/0..** intermedia  
inter./inter./inter.

Fe	60mm	∞	4547 (36x18)	€/u
----	------	---	--------------	-----

o	*o	o	o	o
---	----	---	---	---

o	*o	o	o	o
---	----	---	---	---

o	*o	o	o	o
---	----	---	---	---

o	*o	o	o	o
---	----	---	---	---

o	*o	o	o	o
---	----	---	---	---

o	*o	o	o	o
---	----	---	---	---

EMBELLECEDOR 4720 OPCIONAL  
VIS-DISQUE DE FINITION 4720 OPTIONNEL  
SCREW-EMBELLISHER 4720 OPTIONAL  
DISCO-VITE 4720 OPZIONALE

ESTÁNDAR  
STANDARD

EMBELLECEDOR 4720 OPCIONAL  
VIS-DISQUE DE FINITION 4720 OPTIONNEL  
SCREW-EMBELLISHER 4720 OPTIONAL  
DISCO-VITE 4720 OPZIONALE

ESTÁNDAR  
STANDARD

## TUBO OVALADO 36X18



TUBO OVAL 36x18 mm  
TUBE OVALE 36x18 mm  
OVAL TUBE 36X18 mm  
TUBO OVALE 36X18 mm

**4547/1..** 1M €/m  
**4547/3..** 3M €/u

**TORNILLO-EMBELLECEDOR**  
VIS-DISQUE DE FINITION  
SCREW-EMBELLISHER  
DISCO-VITE

**4720/0..**

Fe	3 m	36x18x1,5
----	-----	-----------

o				
---	--	--	--	--

o				
---	--	--	--	--

∞	4590-4591/4716-4717
---	---------------------

Fe	∅38	€/u
----	-----	-----

o				
---	--	--	--	--

o				
---	--	--	--	--

SE ACONSEJA NO UTILIZAR CON CREMALLERAS DOBLE TROQUEL  
RECOMMANDÉ DE NE PAS UTILISER AVEC DES CRÉMAILLÈRES AVEC DOUBLE EFFORATION  
RECOMMENDED NOT TO USE WITH RACKS WITH DOUBLE SLOT CHANNEL  
NON RACCOMANDATO L'USO CON CREMAGLIERE CON FORATURA DOPPIA



**TAPA FINAL**  
EMBOUT  
END-CAP  
COPRITESTA

**4721/032**

Fe	36x18	∞	4547 (36x18)	€/u
----	-------	---	--------------	-----

o				
---	--	--	--	--



**TAPA FINAL CON TOPE**  
EMBOUT AVEC RÉTENTION  
END-CAP WITH STOP  
COPRITESTA + RETENZIONE

**4722/032**

Zn	46x18	∞	4547 (36x18)	€/u
----	-------	---	--------------	-----

o	*o	o	o	o
---	----	---	---	---

Tube 4547 for hanging bars and lighting system profile 4745  
Tube 4547 pour console penderie et profile éclairage 4745  
Tubo 4547 per appendieria e profilo illuminazione 4745

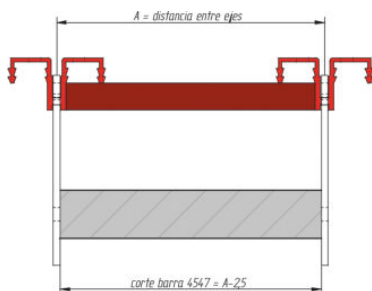

## ACCESORIOS TUBO OVALADO 36X18



**PERROQUET PLANO**  
PENDERIE FRONTAL  
STRAIGHT ARM  
APPENDERIA FRONTALE  
**3019/0..**

**PERROQUET INCLINADO**  
PERROQUET INCLINÉE  
SLOPING ARM  
APPENDERIA INCLINADA  
**3022/0..**

**GANCHO**  
CROCHET  
HOOK  
BARRETTA

**3014/0..** 25 cm  
**3020/0..** 20 cm  
**3021/0..** 10 cm

**GANCHO PORTAPRECIO**  
CROCHET PORTAPRIX  
HOOK LABEL-HOLDER  
BARRETTA PORTAPREZZO

**3012/0..** 25 cm

**PORTAPRECIO**  
PORTAPRIX  
LABELHOLDER  
PORTAPREZZO  
**382/009**

**BLOQUEO GANCHO**  
BLOCCAGE BROCHE  
HOOK SECURITY LOCK  
BLOCCO SICUREZZA GANCIO  
**373/00N**

**BLOQUEO GANCHO DOBLE**  
BLOCCAGE BROCHE DOUBLE  
DOUBLE HOOK SECURITY LOCK  
BLOCCO GANCIO DOPPIO  
**383/00N**

**IMÁN ESPECIAL DESBLOQUEO**  
UNLOCK MAGNET  
UNLOCK MAGNET  
MAGNETE DI SBLOCCO  
**384/000**

## TUBO OVALADO 30X15



**TUBO OVAL 30x15 mm**  
TUBE OVALE 30X15 mm  
OVAL TUBE 30X15 mm  
TUBO OVALE 30X15 mm  
**\*4639/132** 100 cm \*o

**TAPA FINAL**  
EMBOUT  
END-CAP  
**\*4640/0..** \*o

**SOPORTE SUPERIOR**  
SUPPORT TUBE HAUTE  
UPPER TUBE SUPPORT  
SUPPORTO TUBO ALTO  
**\*1400/0..** \*o

**SOPORTE LATERAL**  
SUPPORT TUBE LATÉRAL  
SIDE TUBE SUPPORT  
SUPPORTO TUBO LATÉRALE  
**\*4723/032** \*o

CR. BRILLO	PLÁSTICO	CR. MATE	BLANCO	NEGRO	COLOR
CR. POLI	PLASTIQUE	CHR. M	BLANC	NOIR	COULEUR
CR. LUC.	PLASTICA	M. CHR	WHITE	BLACK	COLORE
		CR. OPAC	BIANCO	NERO	
32	09	31	0B	0N	0P
Fe	∅ 4547	300 mm	€/u		
		*o	o	o	
Fe	∅ 4547	300 mm	€/u		
			o	o	
Fe	∅ 4547	€/u			
			o	o	
		*o	o	o	
Fe	∅ 4547-382	€/u			
		*o	o	o	
plas	40x50 mm	€/u			
			o		
plas	∅6 mm	€/u			
			o		
plas	∅6 mm	€/u			
			o		
plas	373-383/00N	€/u			
			o		
Fe	∅ 3 m	30x15x1,5	€/m		
plas	∅ 4639 (30x15)	€/u			
			NEGRO		
			*o		
Zn	∅ 4639 (30x15)	€/u			
			*o		
Zn	∅ 4639 (30x15)	€/u			

## PERROQUETES



**PERROQUET PLANO**  
PENDERIE FRONTAL  
STRAIGHT ARM  
APPENDERIA FRONTALE  
**4705/032**

Sólo cremalleras  
DUO ∅ 4614-4615 ∅16 330 mm  
**4705/D32**

**PERROQUET INCLINADO**  
PERROQUET INCLINÉE  
SLOPING ARM  
APPENDERIA INCLINADA  
**4706/032**

Sólo cremalleras  
DUO ∅ 4614-4615 ∅16 330 mm  
**4706/D32**

**PERROQUET PLANO "T"**  
PENDERIE LATÉRAL "T"  
LATERAL STRAIGHT ARM "T"  
APPENDERIA LATÉRALE "T"  
**4708/032**

Sólo cremalleras  
DUO ∅ 4614-4615 ∅25 300X400  
**4708/D32**

**PERROQUET PLANO**  
PENDERIE FRONTAL  
STRAIGHT ARM  
APPENDERIA FRONTALE  
**\*4713/032** 30 cm  
**\*4714/032** 20 cm

## SISTEMA PARA CUELQUE DE MUEBLES

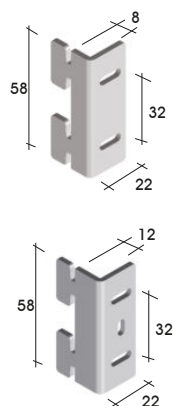

**CARTELA MUEBLES**  
SUPPORT POUR MOBILE  
FURNITURE BRACKET  
MESNOLA PER MOBILI  
**4730/034**

**CARTELA MUEBLES**  
SUPPORT POUR MOBILE  
FURNITURE BRACKET  
MESNOLA PER MOBILI  
**4732/034**

**CARTELA MUEBLES**  
SUPPORT POUR MOBILE  
FURNITURE BRACKET  
MESNOLA PER MOBILI  
**4733/032**

**CARTELA MUEBLES**  
SUPPORT POUR MOBILE  
FURNITURE BRACKET  
MESNOLA PER MOBILI  
**4733/032**

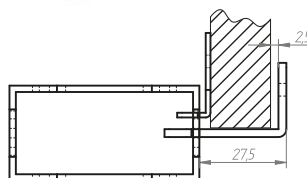

CR. BRILLO	BLANCO	NEGRO
CR. POLI	BLANC	NOIR
CR. LUC.	WHITE	BLACK
	BIANCO	NERO
32	0B	0N
Fe	∅ NO "DUO"	
	∅16 330 mm	€/u
		o
Fe	∅ NO "DUO"	
	∅16 330 mm	€/u
		o
Fe	∅ NO "DUO"	
	∅25 300X400	€/u
		o
Fe	∅ NO "DUO"	
	∅25	€/u
		*o
		*o
Fe	€/u	ZINCADO
		PL. ZINK
		ZINK PL.
		ZINCATO
		<b>34</b>
		o
	∅ 4614-4615	
		€/u
		o
	∅ 4814-4815-4816	
		€/u
		o

**PERFIL 362 PARA SISTEMA KADÍ Y LAMAS**

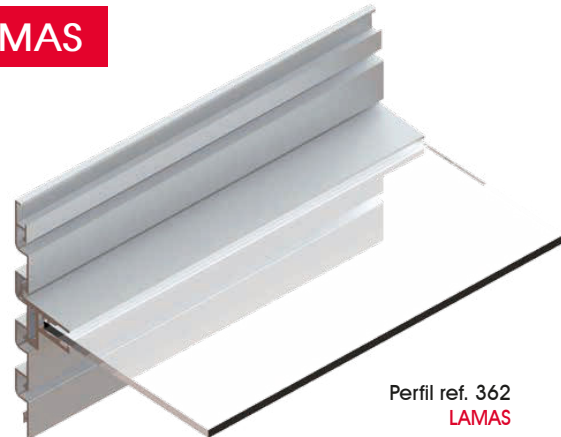
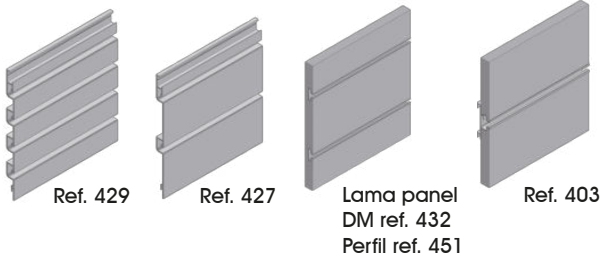

**CARTELAS**



kit 386

**CREMALLERAS KADÍ - ELETRIC**

**SISTEMA ELECTRIFICADO**

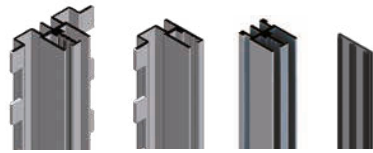

4870 4872 4874 4871

**CARTELAS**



Ref. 366/365

**CREMALLERAS KADÍ**

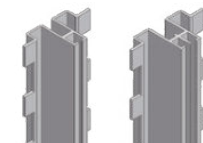

4615 4614

**CARTELAS**



Ref. 368/367

**CREMALLERAS KADÍ**

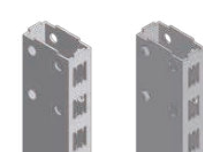

4814/4815 4816



**CARTELAS**



Ref. 364/363

**CREMALLERAS KADÍ**

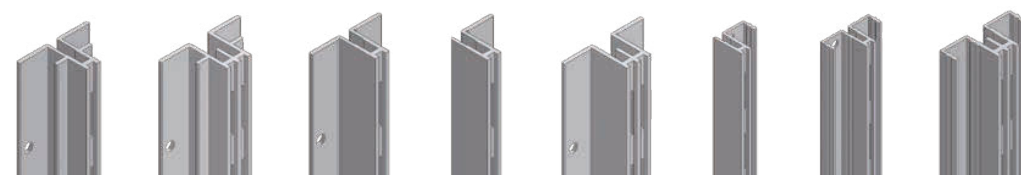

4608 4609 4574 4566 4576 4602 4600 4601

**Perfil aluminio 362**

- Admite estante de vidrio de 6 y 8 mm.  
(SE RECOMIENDA VIDRIO DE SEGURIDAD).  
- Admite iluminación LED en el canal del perfil.

Aluminum profile, 362  
- Allows glass shelf 6 and 8 mm thickness.  
(SAFETY GLASS IS RECOMMENDED)  
- Allows LED lighting.

Profil en aluminium 362  
- Permet étagère en verre de 6 et 8 mm d'épaisseur  
(VERRE DE SÉCURITÉ EST RECOMMANDÉ)  
- Permet l'éclairage LED

Profilo in alluminio, 362  
- Ammette ripiani in vetro di 6 e 8 mm.  
(SI RACCOMANDA L'USO DI VETRO SICURIZZATO)  
- Ammette LEDs.

PERFIL 362

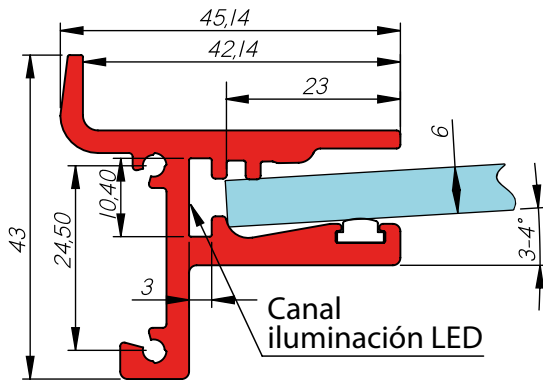
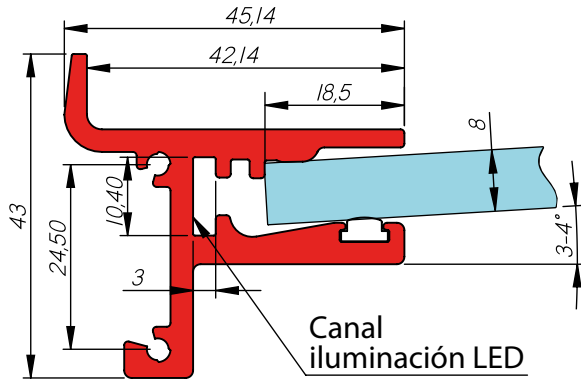

Ancho perfil 362 = Ancho vidrio  
362 aluminum profile width = Glass width  
Largeur du profil 362 = Largeur de verre  
Larghezza profilo 362 = Larghezza di vetro

- Peso max. admitido según tipo de montaje, naturaleza del soporte (pared o mueble), vidrio y número de tornillos de fijación.
- La inclinación del estante puede variar según la carga.
- **Máxima carga para estante vidrio: 25 kg/ml.**
- **Máxima medida estante recomendada: 100 x 30 cm.**

- Max. admitted weight depending on assembly type, on nature of the support (wall or furniture), glass and number of screws used.
- Allows LED lighting.
- The shelf inclination may vary depending on the load.
- **Máx. weight for shelf glass shelf: 50 kg / ml.**
- **Maximum recommended shelf size: 100 x 30 cm.**

- Max. poids admis en fonction du type de montage, la nature du support (mur ou un meuble), le verre et le nombre de vis utilisées.
- Permet l'éclairage LED.
- L'inclinaison de l'étagère peut varier en fonction de la charge.
- **Poids maximum pour étagère en verre: 50 kg / ml.**
- **Taille maximale de l'étagère recommandée: 100 x 30 cm.**

- Peso massimo ammesso a seconda del tipo di montaggio, del tipo di supporto (parete o mobile), vetro o legno e del numero di viti di fissaggio.
- Ammette LEDs.
- L'inclinazione del ripiano può variare a seconda del peso.
- **Peso massimo de ripiano di vetro: 50 kg/ml.**
- **Dimensione massima raccomandata dello scaffale: 100 x 30 cm.**

PERFIL 362



PERFIL ALUMINIO.

PROFIL LAME D'ALUMINIUM  
ALUMINIUM SLATWALL PROFILE  
PROFILO DOGATO ALLUMINIO  
\*362/1..

Junta goma incluida  
joint en caoutchouc inclus  
rubber gasket included  
giunta di gomma inclusa

PL. M	BLANCO	NEGRO	COLOR
ALU. M	BLANC	NOIR	COULEUR
ALL. NAT	WHITE	BLACK	COLOR
	BIANCO	NERO	COLORE
	01	0B	0N 0P

Al	6-8 mm	5 m	€/m
		∞ 361/109	

*o	*o	*o	*o
----	----	----	----

KADÍ CARTELAS



CARGA MEDIA - BAJA

CARTELA OMEGA / ALA / CLASSIC  
SUPPORT OMEGA / ALA / CLASSIC  
OMEGA / ALA / CLASSIC BRACKET  
MENSOLA OMEGA / ALA

\*364/0.. derecha  
droite/right/destra  
\*363/0.. izquierda  
gauche/left/sinistra

BLANCO	NEGRO	COLOR
BLANC	NOIR	COULEUR
WHITE	BLACK	COLOR
BIANCO	NERO	COLORE
	0B	0N 0P

Fe	∞ 362	€/u
----	-------	-----

*o	*o
*o	*o



CARGA MEDIA - BAJA

CARTELA DUO  
SUPPORT DUO  
DUO BRACKET  
MENSOLA DUO

\*366/0.. derecha  
droite/right/destra  
\*365/0.. izquierda  
gauche/left/sinistra

Fe	∞ 362	€/u
----	-------	-----

*o	*o
*o	*o



CARGA MEDIA - BAJA

CARTELA PHARMA / PHARMA DUO  
SUPPORT PHARMA / PHARMA DUO  
PHARMA / PHARMA DUO BRACKET  
MENSOLA PHARMA / PHARMA DUO

\*368/0.. derecha  
droite/right/destra  
\*367/0.. izquierda  
gauche/left/sinistra

Fe	∞ 362	€/u
----	-------	-----

*o	*o
*o	*o



Para perfil 362  
KIT 2 cartelás:  
DERECHA (con  
conector) +  
IZQUIERDA

KIT CARTELAS ESTANTE  
VIDRIO CON  
ILUMINACIÓN  
KIT SUPPORTS VERRE  
ILUMINATION  
GLASS LIGHTING  
BRACKETS KIT  
KIT MENSOLE VETRO  
ILLUMINAZIONE  
\*386/0..

Fe	∞ 362 - 4890	€/u
	68 mm medida útil	

*o	*o
----	----



### ACCESORIOS TUBO OVALADO 36X18

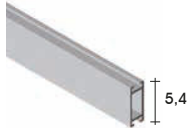

**PERFIL TRAVESERO DOBLE CANAL**  
PROFIL TRVERSE DOUBLE FENTE  
PROFILE DOUBLE SLOT  
PROFILO TRAVERSA DOPPIA CANALE  
\*4535/1..

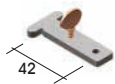

**GALGA PARA GRAPAS 4539 Y 4540**  
OUTIL POUR LES MONTAGE DES  
JOINTS 4539 ET 4540  
MOUNTING TOOL FOR THE JOINTS  
4539 AND 4540  
UTENSILE MONTAGGIO RACCORDI  
4539 E 4540  
4538/000



**GRAPA UNIÓN 4535 CON COLUMNAS**  
SIN CREMALLERA 4606  
JOINT DIRECTE 4535 AVEC COLONNES  
SANS CRÉMAILLÈRE 4606  
DIRECT JOINT 4535 WITH COLUMNS  
WITHOUT RACK 4606  
RACCORDO DIRETTO 4535 CON  
COLONNE SENZA CREMAGUERA 4606  
\*4539/000

### MONTAJE GRAPAS 4539 Y 4540 CON EL PERFIL 4535

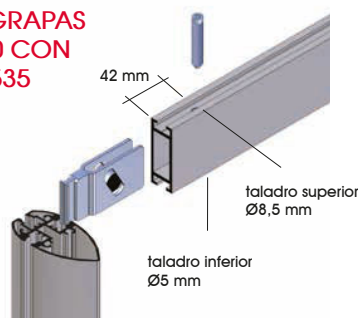

**NIVELADOR SUPERIOR**  
VÉRIN SUPÉRIEUR  
UPPER LEVEL  
LIVELLATORE SUPERIORE  
4541/0..

Fe	∞	4505-4510-4520	€/u
----	---	----------------	-----



**NIVELADOR INFERIOR**  
VÉRIN INFÉRIEUR  
LOWER LEVEL  
LIVELLATORE INFERIORE  
4542/0..

Fe	∞	4505-4510-4520	€/u
----	---	----------------	-----



**ESCUADRA PARA INGLETE A 90°**  
EQUERRE POUR JONCTIONS 90°  
FIXING JOINT 90°  
SQUADRA UNIONI A 90°  
4543/034

Fe	∞	4505-4510-4520	€/u
----	---	----------------	-----



**ENGANCHE A PARED**  
PLAQUE DE FIXATION MURALE  
WALL PLATE CONNECTION  
PLACA FISSAGGIO A PARETE  
4544/0..

Fe	∞	4505-4510-4520	€/u
----	---	----------------	-----

PL. M	BLANCO	NEGRO	COLOR
ALL. M	WHITE	BLACK	COULEUR
ALL. NAT	BIANCO	NERO	COLORE
01	0B	0N	0P

Al	5 m	54x20	€/m
----	-----	-------	-----

*o	*o	*o	*o
----	----	----	----

Fe	∞	4535	€/u
----	---	------	-----

∞	4535-4505-4510-4520	€/u
---	---------------------	-----

Fe	€/u
----	-----

*o			
----	--	--	--

### COMPLEMENTOS "COLUMNS"



**BRAZO PARED TELESCÓPICO**  
FIXATION TÉLESCOPIQUE MUR  
WALL TELESCOPIC CONNECTION  
FISSAGGIO TELESCOPICO A PARETE  
4545/0..

CR. BRLO	BLANCO	NEGRO	COLOR
CR. POLI	WHITE	BLACK	COULEUR
CR. ILLC.	BIANCO	NERO	COLORE
32	0B	0N	0P

Fe	∞	4505-4510-4520	€/u
----	---	----------------	-----

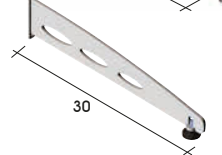

**PIE GÓNDOLA O AUTOPORTANTE**  
PIED GONDOLA OU AUTOPORTANT  
FOOT GONDOLA OR SELF-SUPPORTING  
PIEDE GONDOLA O AUTOPORTANTE  
4559/0.. 30 cm

Fe	∞	4505-4510-4520	€/u
----	---	----------------	-----

M8	€/u
----	-----

NIVELADOR INCLUIDO  
VÉRIN INCLUS  
LEVEL INCLUDED  
LIVELLATORE INCLUSO

*o			
----	--	--	--

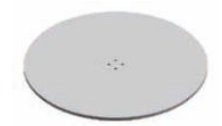

**BASE REDONDA**  
BASE CIRCULAIRE  
ROUND BASE  
BASE CIRCOLARE  
4565/0..

Fe	∞	4505-4510-4520	∅395	€/u
----	---	----------------	------	-----

*o			
----	--	--	--

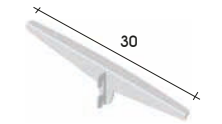

**CARTELA CENTRAL**  
SUPPORT CROCHET CENTRAL  
BRACKET WITH CENTRAL HOOK  
MENSOLA INCASTRO CENTRALE  
4631/0.. 30 cm

Fe	∞	4505-4510-4520+4606	€/u
----	---	---------------------	-----

--	--	--	--



**SOPORTE TUBO OVAL 4547**  
SUPPORT TUBE PENDERIE 4547  
HANGING TUBE 4547 SUPPORT  
SUPPORTO TUBO APPENDERIA 4547  
4546/0..

Fe	∞	4505-4510-4520+4606	€/u
----	---	---------------------	-----

∞	4547 (36x18mm)		
---	----------------	--	--

--	--	--	--



**TUBO OVAL 36x18 mm**  
TUBE OVALE 36X18 mm  
OVAL TUBE 36X18 mm  
TUBO OVALE 36X18 mm  
4547/1..

Fe	∞	3 m	36x18x1,5	€/m
----	---	-----	-----------	-----

--	--	--	--



**CARTELA CENTRAL**  
SUPPORT CROCHET CENTRAL  
BRACKET WITH CENTRAL HOOK  
MENSOLA INCASTRO CENTRALE  
4630/0..

Fe	∞	4505-4510-4520+4606	€/u
----	---	---------------------	-----

--	--	--	--

CR. MATE	INOX	BR	BLANCO	NEGRO	COLOR
CHR. M	INOX	POLI	BLANC	NOR	COULEUR
M. CHR	P.S.S.		WHITE	BLACK	COLOR
CR. OPAC	INOX	LUC	BIANCO	NERO	COLORE
31	22	0B	0N	0P	



**SOPORTE TUBO RECTANGULAR 4585**  
SUPPORT TUBE RECTANGULAIRE 4585  
SUPPORT TUBE RECTANGULAIRE 4585  
SUPPORTO TUBO RETTANGOLARE 4585  
4634/D..

Fe	∞	4585	€/u
----	---	------	-----

--	--	--	--



**TUBO RECTANGULAR**  
TUBE RECTANGULAIRE  
RECTANGULAR TUBE  
TUBO RETTANGOLARE  
4260/122

Fe	∞	6 m	30x10x1,4	€/m
----	---	-----	-----------	-----

--	--	--	--



**PERROQUET PLANO**  
PENDERIE FRONTAL  
STRAIGHT ARM  
APPENDERIA FRONTALE  
4592/0..

Fe	∞	4585	350 mm	€/u
----	---	------	--------	-----

*o			
----	--	--	--



**PERROQUET INCLINADO**  
PERROQUET INCLINÉE  
SLOPING ARM  
APPENDERIA INCLINADA  
4593/0..

Fe	∞	4585	400 mm	€/u
----	---	------	--------	-----

*o			
----	--	--	--

KADÍ PHARMA DUO

MEDIDAS CREMALLERAS Y MECANIZACIONES

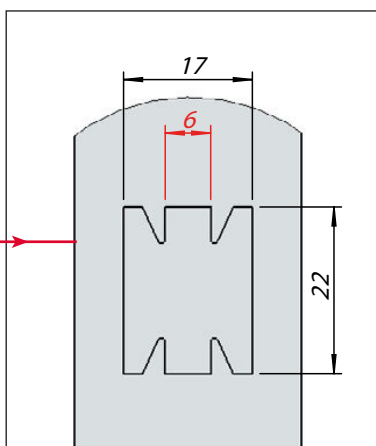
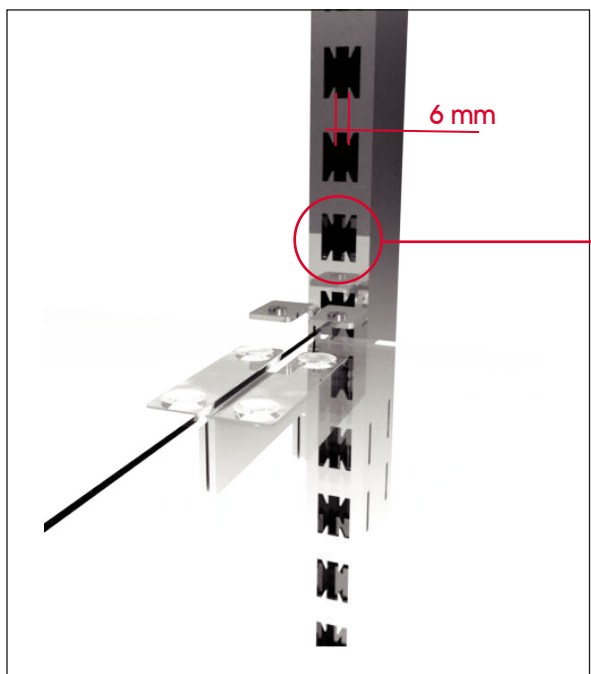

- Con un troquel más ancho.
- Posibilidad de dos cartelas en el mismo alojamiento.
- Avec une mort plus large.
- Possibilité de deux cartes dans le même perforation
- With a wider die.
- Possibility to put two brackets in the same slot.
- Con un dado più ampio.
- Possibilità di due mensole nella stessa asola.

Con la columna PHARMA DUO se pueden usar dos cartelas en un mismo troquel y poder configurar distintas alturas de estantes entre columnas.  
 Avec la colonne PHARMA DUO, vous pouvez utiliser deux cartes dans la même matrice et vous pouvez configurer différentes hauteurs entre étagères entre colonnes.  
 With the PHARMA DUO column you can use two brackets in the same die and configure different heights of shelves between columns.  
 Con la colonna PHARMA DUO è possibile utilizzare due mensole nello stessa asola e regolare i ripiani individualmente.

## SISTEMA KADÍ PHARMA DUO

### CARACTERÍSTICAS DEL SISTEMA

- Compatible con la mayoría de accesorios del sistema Kadí
- Módulos de 512, 730 y 820 mm entrejes de columna
- Posibilidad de regular altura de estantes independientemente.
- Sistema modular que permite la combinación de 3 soluciones:

### CARACTÉRISTIQUES DU SYSTÈME

- Compatible avec la plupart de les accessoires Kadí
- Modules de 512, 730 et 820 mm empattement colonne
- Possibilité de hauteur régulière des étagères indépendantes
- Système modulaire qui permet la combinaison de 3 solutions:

### SYSTEM FEATURES

- Compatible with most Kadí system accessories
- Modules 512, 730 and 820 mm column between axes
- Possibility to adapt height of independent shelves
- Modular system that allows the combination of 3 solutions:

### CARATTERISTICHE DEL SISTEMA

- Compatibile con la maggior parte degli accessori del sistema Kadí
- Moduli di 512, 730 e 820 mm fra assi dei montanti
- Possibilità di altezze regolari di mensole indipendenti
- sistema modulare che permette la combinazione di 3 soluzioni:

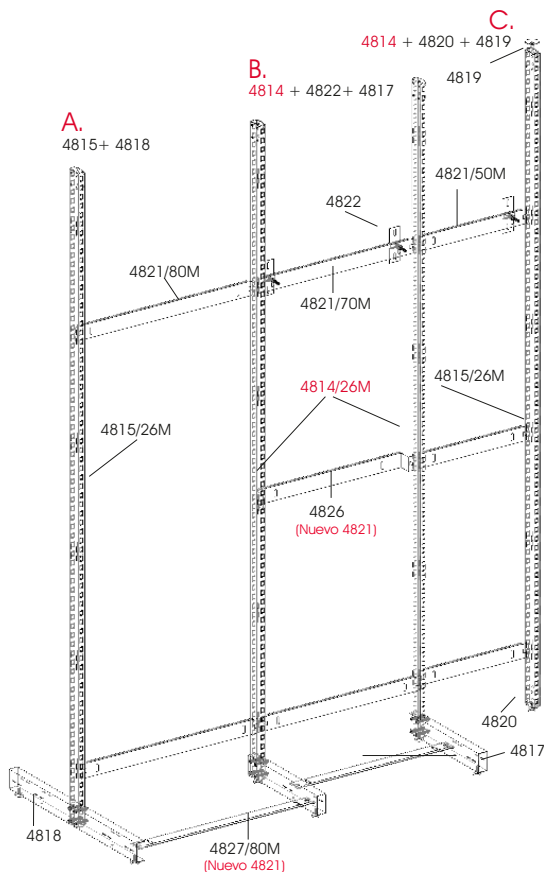

Solución  
ELECTRIFICADO  
Solution ELECTRIFIÉE  
Solution ELECTRIFIED  
Soluzione ELETRIFICATA



Solución TECHO-SUELO  
Solution SOL-PLAFOND  
Solution CEILING-FLOOR  
Soluzione SUOLO-SOFFITTO

### Solución PARED

Solution MUR  
Solution WALL  
Soluzione PARETE

### Solución GÓNDOLA ó PARED DIVISORIA

Solution GONDOLA ou PARIOL SÉPARATRICE  
Solution GONDOLA or PARTITION WALL  
soluzione GONDOLA o parete divisoria

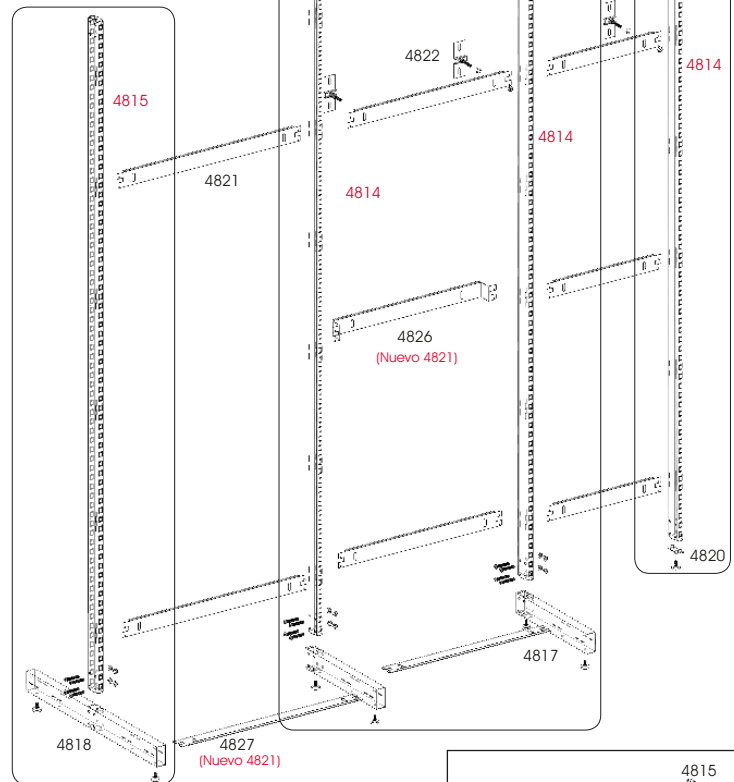

### Solución GÓNDOLA

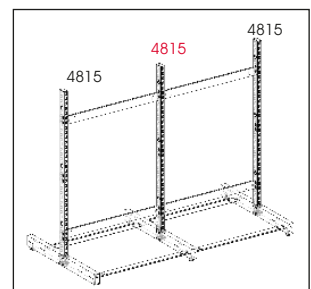
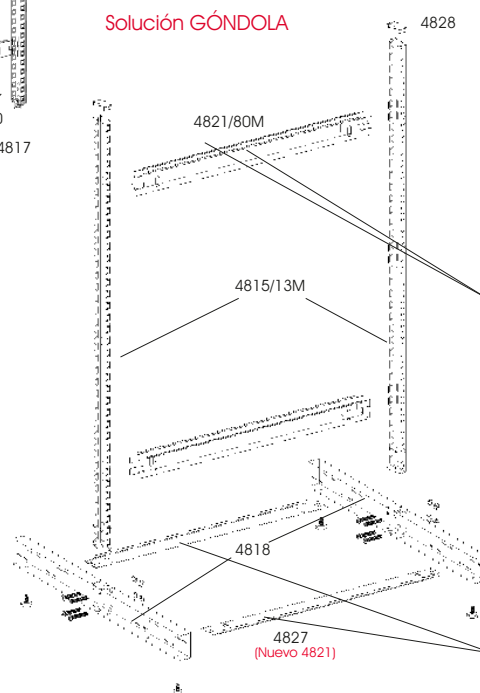

### 4821 TIRANTES EN PLANO DIFERENTES NUEVOS TIRANTES 4821 (APTOS PARA PIES Y MONTANTES)

El uso de tirantes de unión en planos diferentes confiere más estabilidad a la góndola.

La utilisation de tirants dans de planes différents donne plus de stabilité à la gondole

The use of rods spacer in different planes gives more stability to the gondola.

L'impiego di tiranti su piani differenti conferisce maggiore stabilità alla gondola.

### 4827 TIRANTE PARA PIES

El uso de tirantes de unión en planos diferentes confiere más estabilidad a la góndola.

La utilisation de tirants dans la base donne plus de stabilité à la gondole

The use of rods spacer in the base gives more stability to the gondola.

L'impiego di tiranti nella base conferisce maggiore stabilità alla gondola.

**CORTE DE MADERA KADÍ PAHARMA DUO**

**CORTE MADERA PARA UTILIZAR DOS CARTELAS PLEGADAS EN EL MISMO TROQUEL**

couper du bois pour utiliser 2 supports pliés dans le même perforation  
 panel cut to use 2 folded brackets in the same step  
 taglio pannello per inserire 2 mensole piegate nella stessa foratura

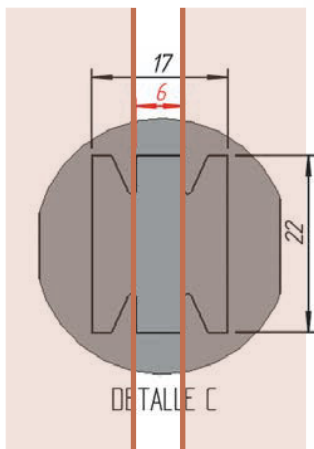
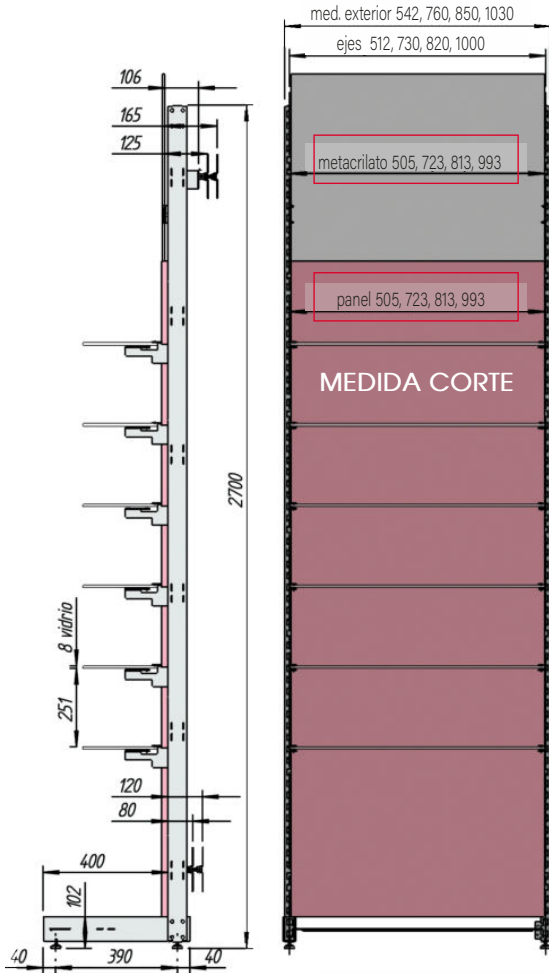

**6 mm**

distribuir los soportes 4823 a distancias multiples de 37 mm (1 soporte cada 90 cm aprox.)

distribute the supports 4823 at distances multiple of 37 mm (1 bracket every 90 cm approx.)  
 distribuez les supports 4823 à des distances multiples de 37 mm (1 support tous les 90 cm approx.)  
 distribuire i supporti 4823 a distanza multiple di 37 mm (1 supporto ogni 90 cm appross.)

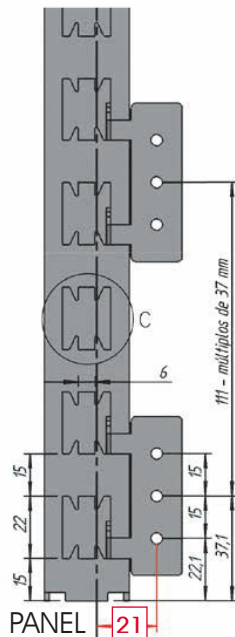

**CORTE MADERA PARA UTILIZAR UNA SOLA CARTELA PLANA EN EL MISMO TROQUEL**

couper du bois pour utiliser 1 support plat dans le même perforation  
 panel cut to use 1 flat bracket in the same step  
 taglio pannello per inserire 1 mensola piana nella stessa foratura

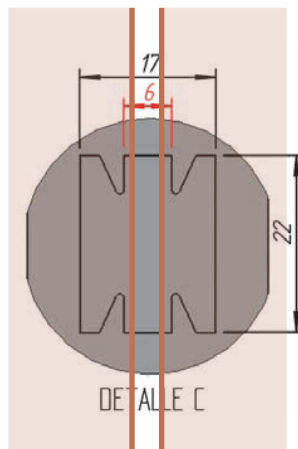
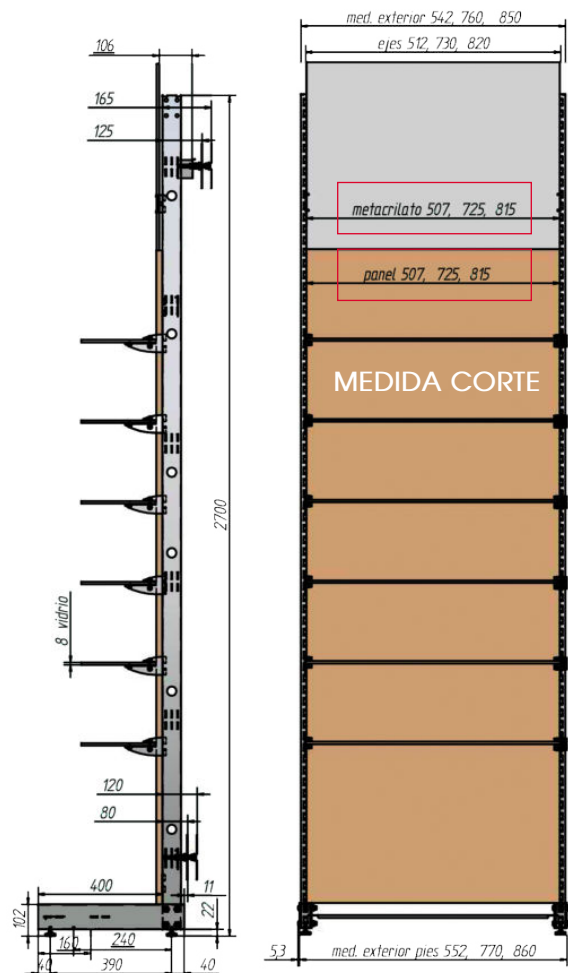

**4 mm**

distribuir los soportes 4823 a distancias multiples de 37 mm (1 soporte cada 90 cm aprox.)

distribute the supports 4823 at distances multiple of 37 mm (1 bracket every 90 cm approx.)  
 distribuez les supports 4823 à des distances multiples de 37 mm (1 support tous les 90 cm approx.)  
 distribuire i supporti 4823 a distanza multiple di 37 mm (1 supporto ogni 90 cm appross.)

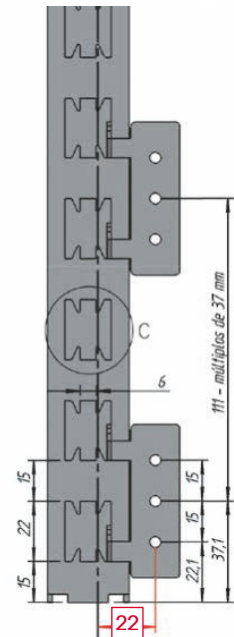

COLUMNAS  
TROQUELADAS

GRIS 7035	BLANCO	NEGRO	COLOR
GRIS 7035	BLANC	NOIR	COULEUR
GRIS 7035	WHITE	BLACK	COLOR
GRIS 7035	BIANCO	NERO	COLOR
OM	OB	ON	OP

GRIS 7035	BLANCO	NEGRO	ZINCADO
GRIS 7035	BLANC	NOIR	PL. ZINC
GRIS 7035	WHITE	BLACK	ZINK PL.
GRIS 7035	BIANCO	NERO	ZINCATO
OM	OB	ON	34

**COLUMNA TROQUELADA 2 CARAS**  
COLONNE PERFORATION SIMPLE 2 CÔTES  
UPRIGHT SINGLE SLOT CHANNEL 2 SIDES  
PIANTANA PERFORAZIONE SINGOLA 2 LATI  
**4815/26B** 2678 mm

Fe	60x30x2 mm	€/u
----	------------	-----

**COLUMNA TROQUELADA 2 CARAS**  
COLONNE PERFORATION SIMPLE 2 CÔTES  
UPRIGHT SINGLE SLOT CHANNEL 2 SIDES  
PIANTANA PERFORAZIONE SINGOLA 2 LATI  
**4815/13B** 1337 mm

Fe	60x30x2 mm	€/u
----	------------	-----

**ANCLAJES PANELES MADERA**  
CROCHET PANNEAUX EN BOIS  
HOOK WOOD PANELS  
GANCIO PER PANNELLI IN LEGNO  
**4823/034**

**ANCLAJES METACRILATO Y VIDRIO**  
SUPPORT METHACRYLATE ET VERRE  
METHACRYLATE AND GLASS SUPPORT  
SUPPORTO PER PLEXIGLAS E VETRO  
**4824/034**

Fe	max.8 mm	€/u
----	----------	-----

**COLUMNA TROQUELADA 1 CARA**  
COLONNE PERFORATION SIMPLE 1 CÔTÉ  
UPRIGHT SINGLE SLOT CHANNEL 1 SIDE  
TUBO PERFORAZIONE SEMPLICE 1 LATO  
**4814/26B** 2678 mm

Fe	60x30x2 mm	€/u
----	------------	-----

	GRUESOS PANELES		
	10 mm	16 mm	19 mm
4645-4646	S	N	N
4620-4621	S	N	N
4622-4623	S	N	N
4626	S	N	N
4652-4653	S	S	S
4654-4655	S	N	N
4656-4657	S	N	N
4705	N	N	N
4706	N	N	N
4708	N	N	N
4715-4716	S	S	S
4717	S	S	S
4730	N	N	N
4731	N	N	N
4732	S	N	N
4733	S	S	S
serie TUBULARES	N	N	N
4618	S	S	S
4619	S	S	S
4680	S	S	S
4681	S	S	S
4682	S	S	S
4683	S	S	S
4684	S	S	S
4695	S	S	S
4696	S	S	S
4691-4692	S	S	S
4693-4694	S	S	S
4844-4845	S	S	S
4846-4847	S	S	S
5844	S	S	S
5845	S	S	S
5846	S	S	S

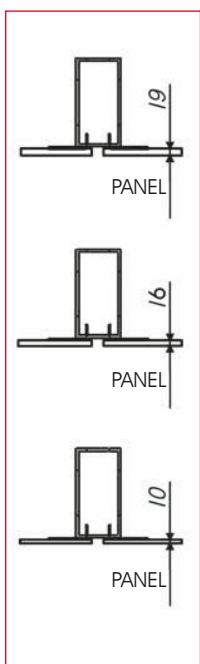

Utilizar las cartelas con panel adecuado.  
Utilisez le supports avec un panneau approprié.  
USE the adequated bracket for the thickness panel  
Utilizzare la mensola con pannello idoneo.

## COMPONENTES

	GRIS 7035	BLANCO	NEGRO	COLOR						
	GRIS 7035	BLANC	NOR	COULEUR						
	GRAY 7035	WHITE	BLACK	COLOR						
	GRIGIO 7035	BIANCO	NERO	COLORE						
	OM	OB	ON	OP						
<p><b>NIVELADOR INCLUIDO</b> VÉRIN INCLUS LEVEL INCLUDED LIVELLATORE INCLUSO</p> <p><b>PIE AUTOPORTANTE A PARED</b> PIED AUTOPORTANT MUR SELF-SUPPORTING FOOT BASE AUTOPORTANTE A PARETE <b>4817/00B</b></p>	Fe				80x40x2 mm	€/u				
<p><b>NIVELADOR INCLUIDO</b> VÉRIN INCLUS LEVEL INCLUDED LIVELLATORE INCLUSO</p> <p><b>PIE AUTOPORTANTE GÓNDOLA</b> PIED GONDOLA GONDOLA FOOT BASE GONDOLA <b>4818/00B</b></p>	Fe				80x40x2 mm	€/u				
<p><b>ANCLAJE TECHO-SUELO</b> VÉRIN SUPÉRIEUR UPPER LEVEL LIVELLATORE SUPERIORE <b>4819/00B</b></p>	Fe				60x30x3 mm M8	€/u				
<p><b>BASE COLUMNA</b> VÉRIN INFÉRIEUR LOWER LEVEL LIVELLATORE INFERIORE <b>4820/00B</b></p>	Fe				60x30x3 mm M8	€/u				
<p><b>KIT DE Z CON RUEDA DE ALTA RESISTENCIA</b> KIT Z AVEC ROUE ROBUSTE Z KIT WITH HEAVY DUTY WHEEL Z KIT CON RUOTA PER SERVIZIO PESANTE <b>4818/ROB</b></p>	Fe				40kg	M10	€/u			
<p><b>MISMO TIRANTE PARA MONTANTES Y PIES</b></p> <p><b>TIRANTES DISTANCIADORES</b> TIRANT-ESPACEMENT TIRANTE-DISTANZIATORE <b>4821/50B</b> eje 512 mm</p> <p><b>4821/60B</b> eje 670 mm</p> <p><b>4821/70B</b> eje 730 mm</p> <p><b>4821/80B</b> eje 820 mm</p> <p><b>4821/10B</b> eje 1000 mm</p>	Fe				€/u					
<p><b>EJACIÓN TIRANTES A PARED</b> PATTES DE FIXATION ROD-SPACER WALL SUPPORT FISSAGIO TIRANTI A PARED <b>4822/00B</b></p>	Fe				€/u					
<p><b>TIRANTE (ILUMINACIÓN)</b> TIRANT-ESPACEMENT (ÉCLAIRAGE) ROD-SPACER (LIGHTING) TIRANTE (ILLUMINAZIONE) *4826/70B eje 730 mm</p> <p>*4826/80B eje 820 mm</p>	Fe				€/u					
<p><b>TIRANTE ENTRE PIES</b> TIRANT-ESPACEMENT ENTRE LE PIED ROD-SPACER BETWEEN FEET TIRANTE FRA BASI MONTANTI *4827/50B eje 512 mm</p> <p>*4827/70B eje 730 mm</p>	Fe				€/u					
<p><b>TIRANTES TELESCÓPICO</b> TIRANT TELESCOPIQUE TELESCOPIC ROD-SPACER TIRANTE TELESCOPICO <b>4840/00B</b></p> <p>módulo 100 cm módulo 90 cm telescopico entre 54,5 y 100 cm</p>	Fe				54,5 <-> 100 cm	€/u				

	CR. BRILLO	BLANCO	NEGRO	ZINCADO						
	CR. POLI	BLANC	NOR	PL. ZINK						
	BR. CHR.	WHITE	BLACK	ZINK PL.						
	CR. ILLUC.	BIANCO	NERO	ZINCATO						
	32	OB	ON	34						
<p><b>BARRA SOPORTE GANCHOS</b> SUPPORT CROCHETS SUPPORT HOOKS BARRA SUPPORTO GANCI <b>4829/7D.</b> eje 730 mm</p> <p><b>4829/8D.</b> eje 820 mm</p> <p><b>4829/1D.</b> eje 1000 mm</p>						Fe	€/u			
<p><b>GANCHO</b> CROCHET HOOK BARRETTA <b>445/X..</b> 20 cm</p>							€/u			
<p><b>GANCHO PORTAPRECIO</b> CROCHET PORTAPRIX HOOK LABEL-HOLDER BARRETTA PORTAPREZZO <b>447/X..</b> 20 cm</p>						Fe	€/u			
<p><b>PORTAPRECIO</b> PORTAPRIX LABELHOLDER PORTAPREZZO <b>382/009</b></p>		plac				40x50 mm	€/u			
<p><b>CARTELA PARA COLGAR MUEBLES</b> SUPPORT POUR MOBILE FURNITURE BRACKET MESNOLA PER MOBILI <b>4733/032</b></p>						Fe	€/u			
<p><b>EMPALMADOR COLUMNA</b> JOINT COLONNES COLUMNS JOINT GIUNZIONE PIANTANE <b>4825/00B</b></p>						Fe	M10	€/u		
<p><b>TAPA COLUMNA</b> BOUCHON END-CAP UPRIGHT COPRITESTA PIANTANA <b>4828/00B</b></p>						Fe	60x30 mm	€/u		

## CARTELA FINAL BARRA ACCESORIOS (36X18)

	CR. BRILLO	BLANCO	NEGRO	COLOR						
	CR. POLI	BLANC	NOR	COULEUR						
	BR. CHR.	WHITE	BLACK	COLOR						
	CR. ILLUC.	BIANCO	NERO	COLORE						
	32	31	OB	ON	OP					
<p><b>CARTELA BARRA ACCESORIOS</b> SUPPORTI BARRE ACCESSORIES BRACKET FOR ACCESSORIES ROD MENSOLA TUBO PORTA-ACCESSORI <b>4716/0..</b> derecha droite/right/destra</p> <p><b>4717/0..</b> izquierda gauche/left/sinistra</p>	Fe					60mm	∞ 4547 (36x18)	€/u		
<p><b>CARTELA BARRA ACCESORIOS</b> SUPPORTI BARRE ACCESSORIES BRACKET FOR ACCESSORIES ROD MENSOLA TUBO PORTA-ACCESSORI <b>4715/0..</b> intermedia inter./inter./inter.</p>	Fe					60mm	∞ 4547 (36x18)	€/u		

## TUBO OVALADO 36X18

<p><b>TUBO OVAL 36x18 mm</b> TUBE OVALE 36X18 mm OVAL TUBE 36X18 mm TUBO OVALE 36X18 mm <b>4547/1..</b></p>	Fe					3 m	36x18x1,5	€/m		
<p><b>GANCHO PORTAPRECIO</b> CROCHET PORTAPRIX HOOK LABEL-HOLDER BARRETTA PORTAPREZZO <b>3012/0..</b> 25 cm</p>		Fe				∞ 4547-382		€/u		
<p><b>PORTAPRECIO</b> PORTAPRIX LABELHOLDER PORTAPREZZO <b>382/009</b></p>		plac				40x50 mm	€/u			

PLÁSTICO  
PLASTIQUE  
PLASTIC  
PLASTICA  
**09**

KADÍ PHARMA



SE RECOMIENDA ESTANTE DE VIDRIO TEMPLADO DE 30CM DE PROFUNDIDAD

CARTELA FINAL ANTIVUELCO  
SUPPORT FINAL ANTIBASCULAMENT  
FINAL BRACKET ANTITIPPING  
MENSOLA FINALE ANTIRIBALTAMENTO  
\*4618/3..



SE RECOMIENDA ESTANTE DE VIDRIO TEMPLADO DE 30CM DE PROFUNDIDAD

CARTELA INTERMEDIA ANTIVUELCO  
SUPPORT INTERMÉDIAIRE ANTIBASCULAMENT  
INTERMEDIATE BRACKET ANTITIPPING  
MENSOLA INTERMEDIA ANTIRIBALTAMENTO  
\*4619/3..

CARTELA "SILUETTE"

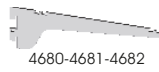

4680-4681-4682

CARTELA SUPPORT BRACKET MENSOLA



4683-4684

4680/0.. 14cm  
4681/0.. 23cm  
4682/0.. 28cm  
4683/0.. 33cm  
4684/0.. 38cm

CARTELA "SILUETTE" INCLINADA



CARTELA INCLINADA 30°  
SUPPORT INCLINÉE 30°  
SLOPING BRACKET 30°  
MENSOLA INCLINATA 30°  
4696/0.. 32cm

CABALLETES ESTANTES PARA CARTELAS



ALETA FINAL CAVALIER FINAL FINAL SADDLES CAVALIERE FINALE  
4700/0..



ALETA INTERMEDIA CAVALIER DOUBLE BOUBLE SADDLES CAVALIERE DOPPIO  
4701/0..



APOYO APPUI SUPPORT APPOGGIO  
4702/009



VENTOSA VENTOUSE SUCTION VENTOSA  
319/009



VENTOSA VENTOUSE SUCTION VENTOSA  
2556/009

ESTANTES DE VIDRIO 8 mm support verre 8 mm recommandée recommended 8mm glass bracket mensola per vetro 8 mm consigliata



ESTANTES DE MADERA O VIDRIO supports verre/bois recommandée recommended glass/wood brackets mensola per vetro/legno consigliata

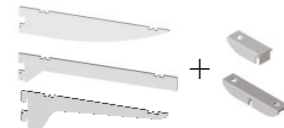

La profundidad de estante recomendado para las cartelas suspendidas de la gama "CARTELAS ESPECIALES VIDRIO" es de 25-30 cm max. La profundidad del estante interfiere directamente en la capacidad y resistencia de aguante de las mismas cartelas y de todo el sistema.

CR. BRILLO	INOX SAT	BLANCO	NEGRO	COLOR
CHR. POLI	S.S.S.	WHITE	BLACK	COULEUR
BR. CHR.	INOX SAT	BIANCO	NERO	COLOR
CR. ILLC.		BIANCO	NERO	COLORE
32	28	0B	0N	0P

KADÍ PHARMA  
DUO

CARTELAS ESPECIALES PARA PHARMA, CREMALLERA DUO Y ELECTRIFICADO. (APTO PARA TODOS LOS SISTEMAS KADÍ)



CARTELA SUPPORT BRACKET MENSOLA



5844/... derecha droite/right/destra  
5845/... izquierda gauche/left/sinistra



5846/... doble double/double/doppio



CARTELA DERECHA SUPPORT DROITE RIGHT BRACKET MENSOLA DESTRA  
\*4844/0..



CARTELA IZQUIERDA SUPPORT GAUCHE LEFT BRACKET MENSOLA SINISTRA  
\*4845/0..

"SILUETTE" PLEGADA



CARTELA SUPPORT BRACKET MENSOLA



4692/0.. derecha droite/right/destra  
4691/0.. izquierda gauche/left/sinistra



4694/0.. derecha droite/right/destra  
4693/0.. izquierda gauche/left/sinistra

CARTELAS "GRANDES PESOS"



CARTELA GRANDES PESOS SUPPORT GRAN POID BRACKET HEAVY WEIGHT MENSOLA GRANDI PESI  
4652/0.. derecha droite/right/destra  
4653/0.. izquierda gauche/left/sinistra



CARTELA INCLINADA 30° SUPPORT INCLINÉE 30° SLOPING BRACKET 30° MENSOLA INCLINATA 30°  
4632/0.. derecha droite/right/destra  
4633/0.. izquierda gauche/left/sinistra



CARTELA ESTANTE MADERA SUPPORT TABLETTES BOIS WOOD SHELF BRACKET MENSOLA RIPIANO LEGNO



4676/0.. derecha droite/right/destra  
4675/0.. izquierda gauche/left/sinistra



350

CR. BRILLO	INOX SAT	BLANCO	NEGRO	COLOR
CHR. POLI	S.S.S.	WHITE	BLACK	COULEUR
BR. CHR.	INOX SAT	BIANCO	NERO	COLOR
CR. ILLC.		BIANCO	NERO	COLORE
32	31	0B	0N	0P



**SEPARADORES Y PORTAPRECIOS**

**SEPARADORES CON DISPENSADOR DE PRODUCTO**

SÉPARATEURS ET PUSSEURS  
DEVIDERS AND PUSHERS  
SEPARATORI E PUSHERS



SEPARADOR FINAL IZQUIERDA  
ESTANTE 30 cm  
SÉPARATEUR EXTRÉMITÉ GAUCHE  
TABLETTE 30 cm  
LEFT SIDE SHELF DIVIDER SHELF 30cm  
SEPARATORE ESTREMITÀ SINISTRA  
RIPIANO 30 cm  
**4833/009** transp.

plas 285mm €/u



SEPARADOR FINAL DERECHA  
ESTANTE 30 cm  
SÉPARATEUR EXTRÉMITÉ DROITE  
TABLETTE 30 cm  
RIGHT SIDE SHELF DIVIDER SHELF 30cm  
SEPARATORE ESTREMITÀ DESTRA  
RIPIANO 30 cm  
**4834/009** transp.

plas 285mm €/u



SEPARADOR INTERMEDIO  
ESTANTE 30 cm  
SÉPARATEUR CENTRAL TABLETTE 30cm  
CENTRE SHELF DIVIDER SHELF 30 cm  
SEPARATORE CENTRALE  
RIPIANO 30cm  
**4835/009** transp.

plas 285mm €/u



DISPENSADOR CON MUELLE  
ESTANTE 30 cm  
DISTRIBUTEUR À PRESSION DE  
PRODUIT TABLETTE 30 cm  
PUSHER SHELF 30 cm  
DISTRIButore A PRESSIONE  
RIPIANO 30 cm  
**4836/009**

plas 285mm €/u

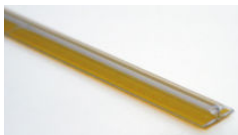

GUÍA POSTERIOR ADHESIVA  
GUIDE DERRIÈRE ADHÉSIF  
ADESIVE BACK GUIDE  
GUIDA POSTERIORE ADESIVA  
**4832/109** transp.

plas 39 mm €/m

plas 1m

plas 1m

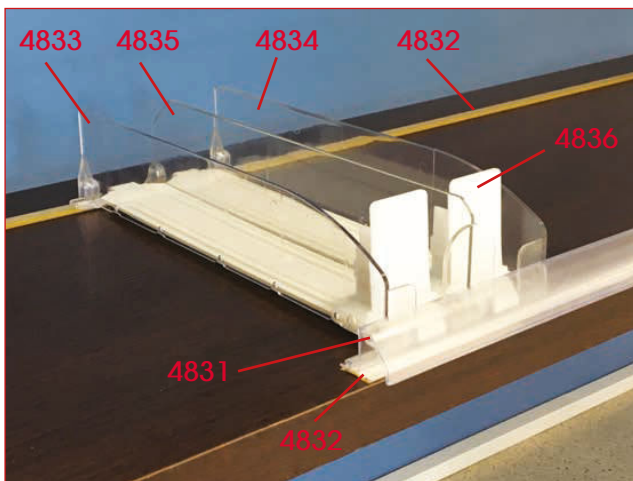

**PORTAPRECIOS PARA VIDRIO Y MADERA**

TITULAIRE DE PRIX POUR VERRE ET BOIS  
PRICE HOLDER FOR GLASS AND WOOD  
DETENTORE DEL PREZZO PER VETRO E LEGNO



GUÍA FRONTAL ESTANTE DE VIDRIO  
GUIDE FRONTAL ÉTAGÈRE EN VERRE  
FRONT GLASS SHELF GUIDE  
GUIDA FRONTALE RIPIANO IN VETRO  
**4830/109** transp.

plas 1m  
6-10 mm  
38 mm €/m

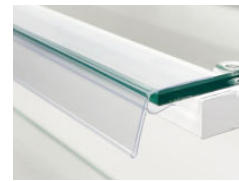

GUÍA FRONTAL ESTANTE DE VIDRIO  
GUIDE FRONTAL ÉTAGÈRE EN VERRE  
FRONT GLASS SHELF GUIDE  
GUIDA FRONTALE RIPIANO IN VETRO  
**4837/109** transp.

plas 1m  
6-10 mm  
28 mm €/m



GUÍA FRONTAL ESTANTE DE VIDRIO  
GUIDE FRONTAL ÉTAGÈRE EN VERRE  
FRONT GLASS SHELF GUIDE  
GUIDA FRONTALE RIPIANO IN VETRO  
**4848/109** transp.

plas 1m  
10 mm  
38 mm €/m

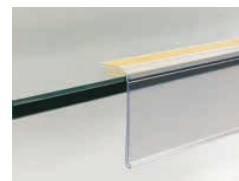

GUÍA FRONTAL ESTANTE DE VIDRIO / MADERA  
GUIDE FRONTAL ÉTAGÈRE EN VERRE / BOIS  
FRONT GLASS / WOOD SHELF GUIDE  
GUIDA FRONTALE RIPIANO IN VETRO / LEGNO  
**4849/109** transp.

plas 1m  
40 mm €/m



GUÍA FRONTAL ADHESIVA ESTANTE DE MADERA  
GUIDE FRONTAL ADHÉSIF ÉTAGÈRE EN BOIS  
ADHESIVE FRONT WOOD SHELF GUIDE  
GUIDA FRONTALE ADESIVA RIPIANO IN LEGNO  
PLÁSTICO TRANSPARENTE  
**4831/109** transp.

plas 1m  
26 mm €/m

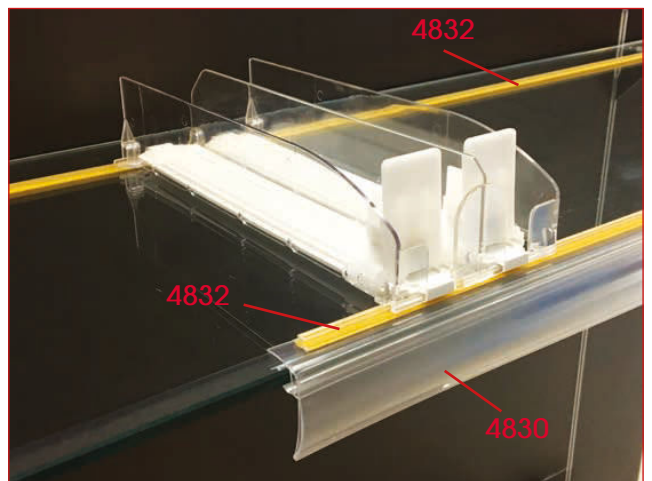

## KADÍ PRIMO 25X25

TUBO TROQUELADO 25X25MM

KADÍ PRIMO es un sistema modular para crear todo tipo de muebles en tubo de hierro 25x25 mm.  
Sistema compatible con cartelas y accesorios Kadí.

Kadí Primo est un système modulaire pour créer toutes sortes de meubles en tubes 25x25 mm.  
Système compatible avec les supports et accessoires Kadí.

Kadí Primo is a modular system to create all kinds of furniture in iron 25x25 mm tube.  
System compatible with Kadí brackets and accessories.

KADÍ PRIMO è un sistema modulare per creare tutti i tipi di mobili in tubo di ferro 25x25 mm.  
Sistema compatibile con mensole e accessori Kadí.



**KADÍ PRIMO**

SISTEMA KADÍ-PRIMO: COMPATIBLE  
CON ACCESORIOS SISTEMA KADÍ

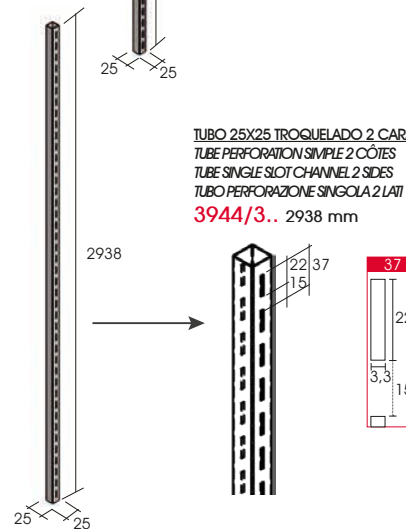
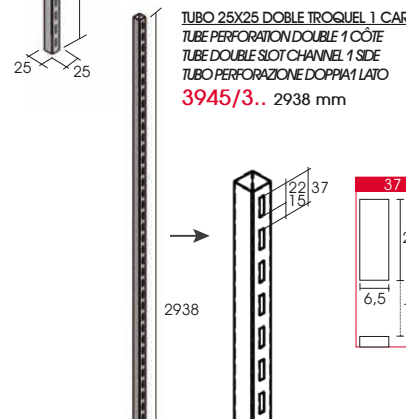
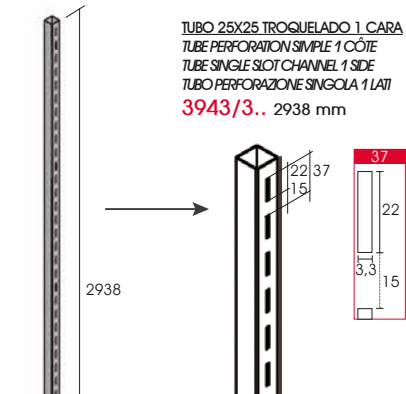

BLANCO	NEGRO	COLOR
BLANC	NOIR	COULEUR
WHITE	BLACK	COLOR
BIANCO	NERO	COLORO
OB	ON	OP

25x25x1,2 mm	Fe	€/u
--------------	----	-----

25x25x1,2 mm	Fe	€/u
--------------	----	-----

25x25x1,2 mm	Fe	€/u
--------------	----	-----

Fe	€/u
----	-----





**EJEMPLOS DE MONTAJE PRIMO**

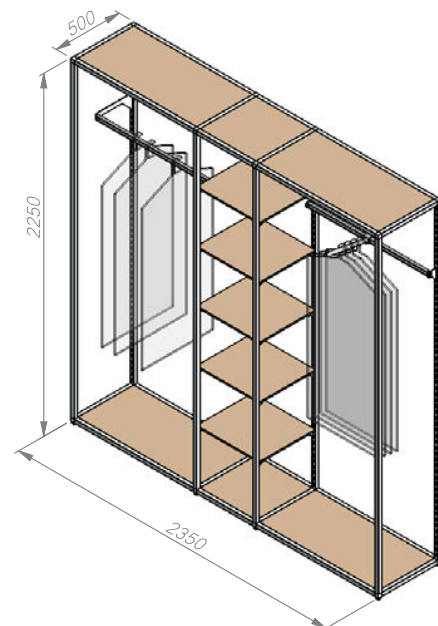
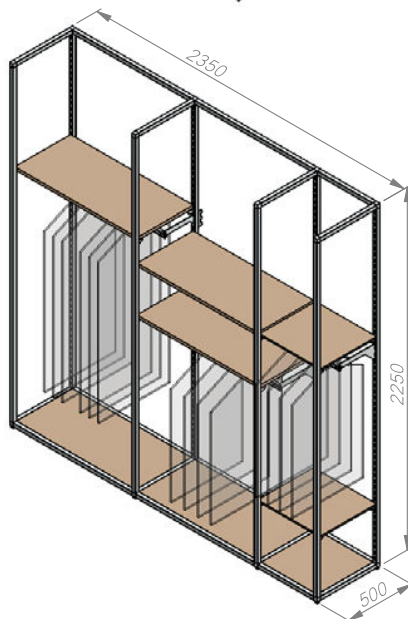
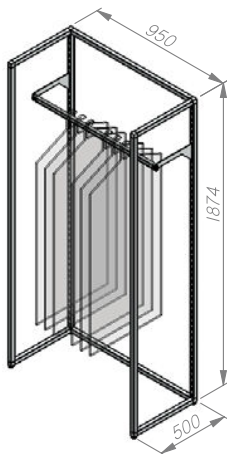
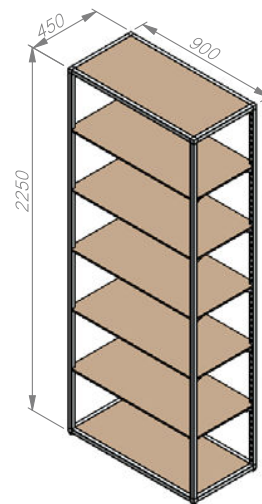
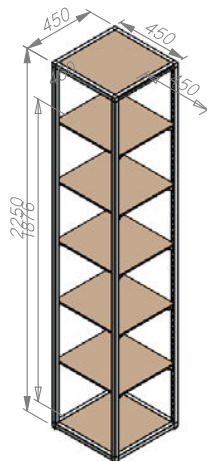
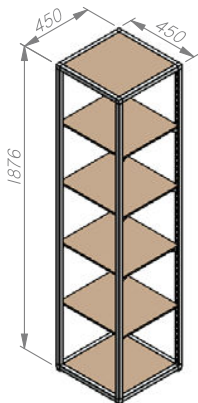
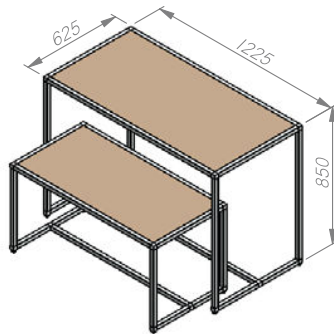
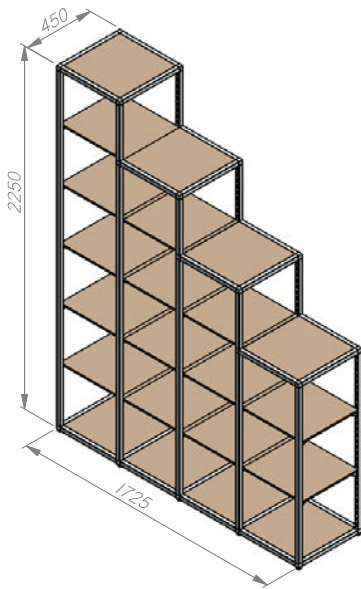

EJEMPLOS DE MONTAJE NUDOS BRIDA

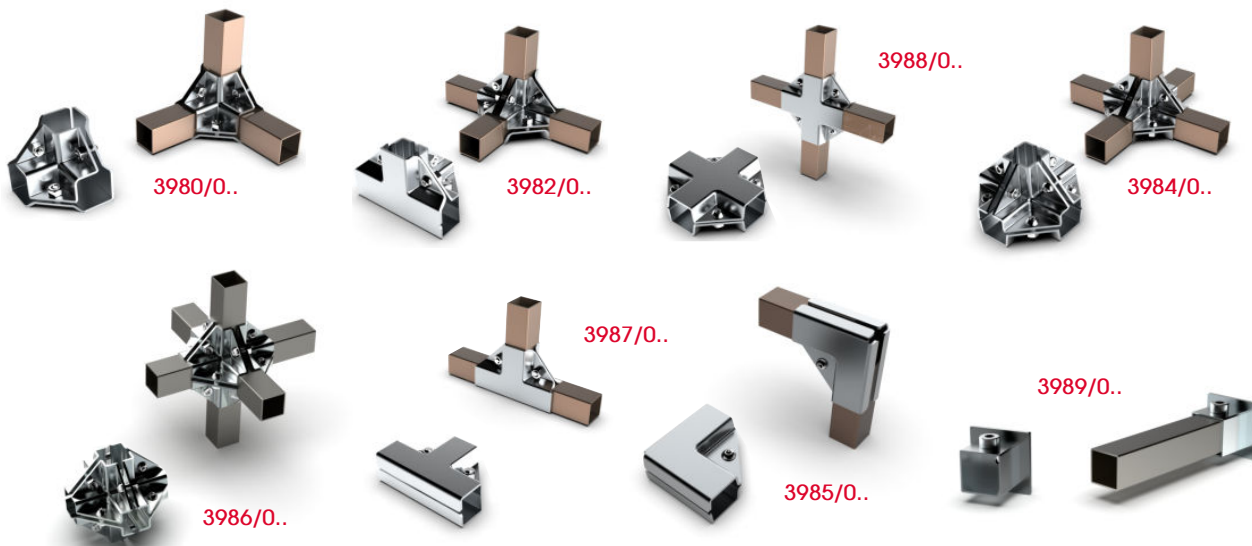

TUBO 25X25







instal.

# LAMAS

SISTEMAS SIN ILUMINACIÓN

**SISTEMA LAMAS**

**PANELES Y PERFILES**

**SISTEMA LAMAS 361**  
COMPONENTES

**LAMAS - CASQUILLO**

**LAMAS - "INVISIBLE" 403**

**LAMAS - DM**

**LAMAS - ALUMINIO**

**ACCESORIOS LAMAS**  
ACCESORIOS HIERRO  
ACCESORIOS ALUMINIO  
ACCESORIOS PLÁSTICO

**PARALELO 384**  
ACCESORIOS

**PERFIL PARALELO MAXI 389**

**OPTI 3**  
INFORMACIÓN TÉCNICA

SISTEMA LAMAS



**Accesorios para perfil invisible 361**

*Accessoires pour le profil INVISIBLE 361*

*Fittings for the INVISIBLE profile 361*

*Accessori per il Profilo INVISIBLE 361*

PANELES Y PERFILES

PANNEAUX ET PROFILS / PANELS AND PROFILES / PANNELLI E PROFILI

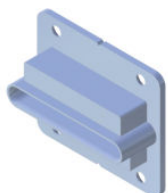

Casquillo LAMAS  
ref. 359

Insert LAMAS  
LAMAS socket  
Boccola LAMAS



Lamas INVISIBLE  
ref. 361

Profil INVISIBLE  
INVISIBLE profile  
Profilo INVISIBLE

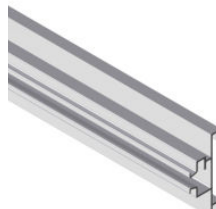

Lamas INVISIBLE+cremallera  
ref. 403 + ref. 400

Profil INVISIBLE + crémaillère  
INVISIBLE profile + rack  
Profilo INVISIBLE + cremagliera

COMPATIBLES CON:

COMPATIBLE AVEC :

COMPATIBLE WITH:

COMPATIBLE CON:

STOCK ALU SYSTEM

1. accesorios hierro  
accessoires en fer, iron fittings, accessori di ferro
2. accesorrios aluminio  
accessoires aluminium, aluminium fittings,  
accessori alluminio
3. accesorios plástico  
accessoires plastique, plastic fittings, accessori  
plastica

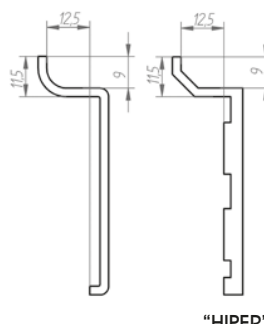
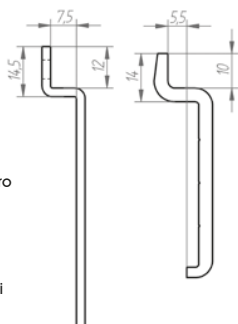

"HIPER"

COMPATIBLES CON:

COMPATIBLE AVEC :

COMPATIBLE WITH:

COMPATIBLE CON:

accesorios "HIPER"

(no stock)

accessoires "HIPER",  
"HIPER" fittings, accessori "HIPER"



Lamas "DM" ref. 477-432

Panneau rainuré MDF avec profils  
slatwall panel MDF with profiles  
Pannello dogato MDF con profili

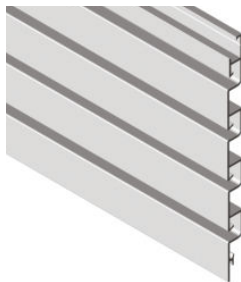

Lama aluminio ref. 429

Profil LAME D'ALUMINIUM  
ALUMINIUM SLATWALL profile  
Profilo DOGATO DI ALLUMINIO

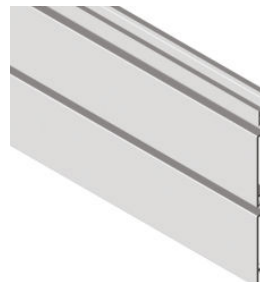

Lama aluminio ref. 427

Profil LAME D'ALUMINIUM  
ALUMINIUM SLATWALL profile  
Profilo DOGATO DI ALLUMINIO



Perfil para "DM" ref. 450

Profil d'aluminium x panneau rainuré  
aluminium profile x slatwall panel  
Profilo di alluminio x pannello dogato

COMPATIBLES CON:

COMPATIBLE AVEC :

COMPATIBLE WITH:

COMPATIBLE CON:

STOCK ALU SYSTEM

1. accesorios hierro  
accessoires en fer, iron fittings, accessori di ferro
- ⊗ 2. accesorrios aluminio  
accessoires aluminium, aluminium fittings,  
accessori alluminio
3. accesorios plástico  
accessoires plastique, plastic fittings, accessori  
plastica

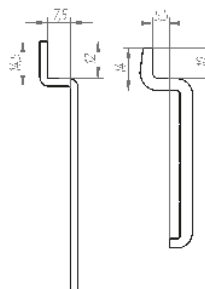

SISTEMA LAMAS 361

LAMA DE ALUMINIO INVISIBLE 361

- Admite estante de vidrio de 6 y 8 mm SE RECOMIENDA VIDRIO DE SEGURIDAD
- Sistema machihembrado
- Peso max. admitido según tipo de montaje: Estante vidrio 8 mm: 50 kg/ml / Estante vidrio 6 mm: 25 kg/ml
- Accesorios: 20 kg/u. ó peso max. admitido por cada accesorio (si inferior a 20 kg)
- Admite iluminación LED en el canal del perfil
- Compatibles con accesorios estándar de Lamas (admite accesorios tipo "Hiper") y accesorios especiales 361

LAMA aluminium INVISIBLE 361

- Permet étagère en verre de 6 et 8 mm d'épaisseur
- Verre de sécurité est recommandé
- montage panneau à emboîtement
- Max. poids admis en fonction du type de montage:
- Étagère en verre de 8mm: 50 kg / ml
- Étagère en verre de 6mm: 6 mm 25 kg / ml
- Accessoires: 20 kg / u. ou poids max. approprié pour chaque accessoire (si moins de 20 kg)
- Permet l'éclairage LED
- Compatible avec les accessoires standards (Lamas et raccords spéciaux tels que "Hiper") et accessoires spéciaux 361

LAMA aluminium INVISIBLE 361

- Allows glass shelf 6 and 8 mm thick
- Safety glass is recommended
- Socket joint or panel fitting from behind.
- Max. admitted weight depending on assembly type:
- 8 mm glass shelf: 50 kg / ml
- 6 mm glass shelf: 25 kg / ml
- Accessories: 20 kg / u. weight or max. suitable for each accessory (if less than 20 kg)
- Allows LED lighting
- Compatible with standard accessories Lamas (and special fittings such as "Hiper") and special fittings 361 series

LAMA alluminio INVISIBLE 361

- ammette ripiani in vetro di 6 e 8 mm
- Si raccomanda l'uso di vetro sicurizzato
- Sistema incastro
- Peso massimo ammesso a seconda del tipo di montaggio:
- Ripiano di vetro 8 mm: 50 kg/ml
- Ripiano di vetro 6 mm: 25 kg/ml
- Accessori: 20 kg/u. o peso massimo ammesso per cadauno (se inferiore a 20 kg).
- Ammette LEDs
- Compatibile con accessori standard Lamas (e accessori speciali tipo "Hiper") e accessori speciali 361



MONTAJE A PARED

Montaje mural / Wall mounting / Montaggio a parete

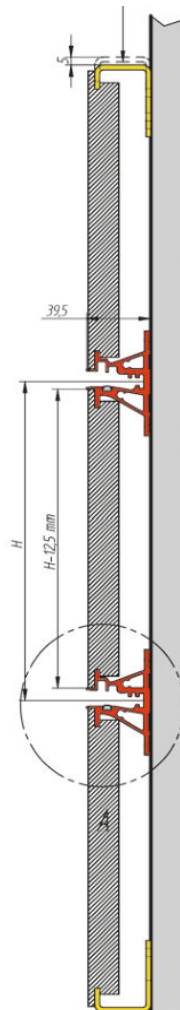
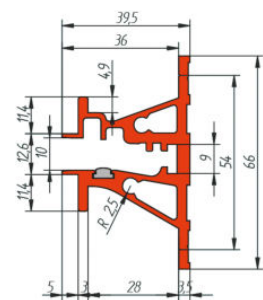
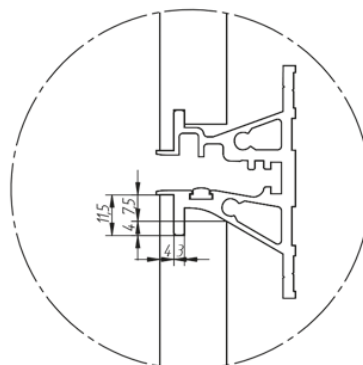

COMPONENTES

LAMAS "INVISIBLE"

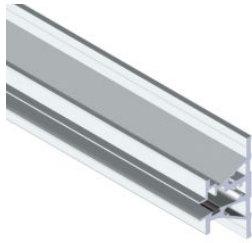

LAMA ALUMINIO  
PROFIL D'ALUMINIUM  
ALUMINIUM PROFILE  
PROFILO DI ALLUMINIO

Al	5 m	6/8 mm	€/m
----	-----	--------	-----

COMPATIBLE CON:  
ACC. ESTÁNDAR LAMAS  
ACC. ESPECIALES HIPER.  
ACC. 361  
361/1..

OB	ON	OP	01
○	○	○	○

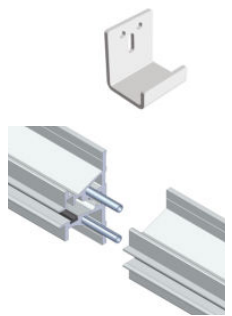

SOPORTE PANEL  
INFERIOR/SUPERIOR  
SUPPORT BOIS  
INFÉRIEUR / SUPÉRIEUR  
WOOD SUPPORT LOWER / UPPER  
SUPPORTO PANNELLO LEGNO  
INFERIORE / SUPERIORE  
370/00B

Fe	45x35x40	€/u
----	----------	-----

PASADOR UNIÓN PERFILES Ø5 mm  
BROUCHE À RESSORT Ø 5 mm  
BOLT JOINING PROFILES Ø 5 mm  
PERNO A MOLLA Ø 5 mm  
358/000

Fe	600x380 mm	€/u
∞	361	€/u

Estantes  
de vidrio  
se recomienda  
vidrio templado

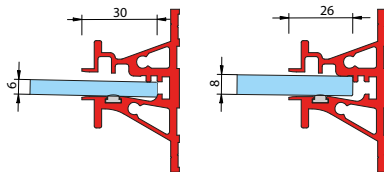

Accesorios LAMAS    Accesorios HIPER    Accesorios 361

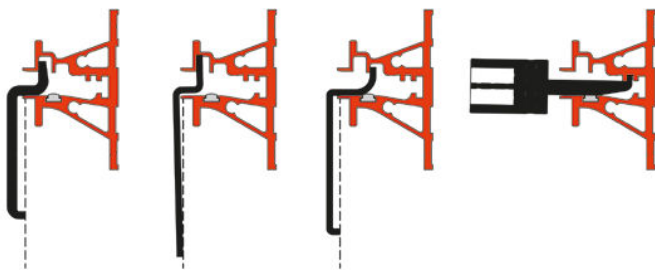

ACCESORIOS



SUPPORTO ACCESSORIOS  
SUPPORT ACCESSOIRES  
ACCESSORIES SUPPORT  
SUPPORTO ACCESSORI  
300/031

CR. BRILLO CHR. POLI BR. CHR CR. LUC.	CR. MATE CHR. M M. CHR CR. OPAC	COLOR COULEUR COLOR COLORE
32	31	0P

para tubo Ø25x1,5 mm  
inox  
s.s. €/u



CARTELA  
SUPPORT  
BRACKET  
MENSOLA  
305/0..

Fe	∞ 361	350 mm	€/u
----	-------	--------	-----



GANCHO  
CROCHET  
HOOK  
GANCIO  
\*306/0..

Fe	∞ 361	200 mm	€/u
----	-------	--------	-----

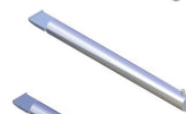

PERROQUET PLANO  
PENDERIE FRONTAL  
STRAIGHT ARM  
APPENDERIA FRONTALE  
301/0.. 250 mm  
309/0.. 350 mm

Fe	∞ 361	€/u
----	-------	-----

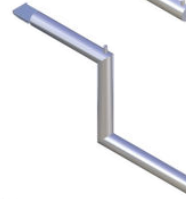

PERROQUET PLANO "S"  
PENDERIE FRONTAL "S"  
STRAIGHT ARM "S"  
APPENDERIA FRONTALE "S"  
307/0..

Fe	∞ 361	€/u
∞	361	€/u



PERROQUET INCLINADO  
PERROQUET INCLINÉE  
SLOPING ARM  
APPENDERIA INCLINADA  
302/0..

Fe	∞ 361	€/u
∞	361	€/u

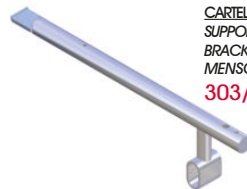

CARTELA + BARRA PENDERIE  
SUPPORT + BARRE PENDERIE  
BRACKET + HANGING BAR  
MENSOLA + APPENDERIA  
303/0..

Fe	∞ 361 - 4547	€/u
∞	361 - 4547	€/u

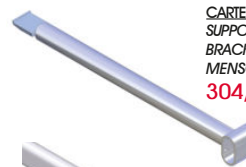

CARTELA BARRA PENDERIE  
SUPPORT BARRE PENDERIE  
BRACKET HANGING BAR  
MENSOLA APPENDERIA  
304/0..

Fe	∞ 361 - 4547	€/u
∞	361 - 4547	€/u



TUBO OVAL 36x18 mm  
TUBE OVALE 36X18 mm  
OVAL TUBE 36X18 mm  
TUBO OVALE 36X18 mm  
4547/10P

Fe	∞ 1 m	€/m
∞	36x18x1,5	€/m



TAPA FINAL CON TOPE  
EMBOUT AVEC RÉTENTION  
END-CAP WITH STOP  
COPRITESTA + RETENZIONE  
4722/0..

Zn	46x18	€/u
∞	4547 (36x18)	€/u

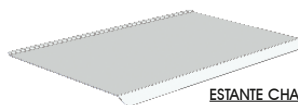

ESTANTE CHAPA  
TABLETTE EN MÉTAL  
METAL SHELF  
RIPIANO METALLICO  
\*371/00M

Fe	600x380 mm	€/u
∞	361	€/u

RAL 9006  
\*○



LAMAS - "INVISIBLE" 403

INSTALACIÓN CON CREMALLERA

SISTEMA MACHIEMBRADO  
compatibles con accesorios  
estándar de "Lamas" y  
especiales "Hiper"

SOCKET JOINT SYSTEM  
compatible with standard accessories  
"Lamas" and special accessories "Hiper"

SYSTÈME EMBOÏTEMENT  
compatible avec les accessoires standard  
"Lamas" et accessoires spéciaux "Hiper"

SISTEMA A INCASTRO  
compatibile con accessori standard  
"Lamas" e con accessori speciali "Hiper"

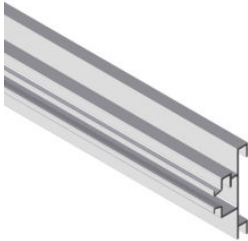

LAMA ALUMINIO CON  
CREMALLERA REF. 400  
MADERA: 10-16 mm  
compatible con:  
acc. estándar Lamas  
Acc. especiales "HIPER"

PROFIL D'ALUMINIUM "LAMAS"  
POUR CRÉMAILLÈRE REF 400  
Bois 10-16 mm  
Compatible avec:  
Acc standard Lamas  
Acc. spécial Hiper

ALUMINIUM PROFILE "LAMAS"  
WITH RACK REF. 400  
Wood 10-16 mm  
Compatible with:  
Acc Lamas Standard  
Acc. Hiper Special

PROFILO DI ALLUMINIO "LAMAS"  
CON CREMAGLIERA REF 400  
Legno 10-16 mm  
Compatibile con:  
Acc. standard Lamas  
Acc speciali Hiper  
403/1..

CREMALLERA PARED  
PARA PERFILES 401, 403

CRÉMAILLÈRE MUR  
Avec profils 403 et 401  
WALL RACK  
for profiles 403 y 401  
CREMAGLIERA PARETE  
con profili 403 e 401  
400/334

BLANCO BLANC WHITE BIANCO	NEGRO NOIR BLACK NERO	COLOR COULEUR COLOR COLORE	PL. M ALU. M ALL. M ALL. NAT
OB	ON	OP	O1

Al	5 m
178x12,5	€/m

Al	3 m	∞	401-403	€/m
			ZINCADO PL. ZINK ZINK PL ZINCATO	
			34	

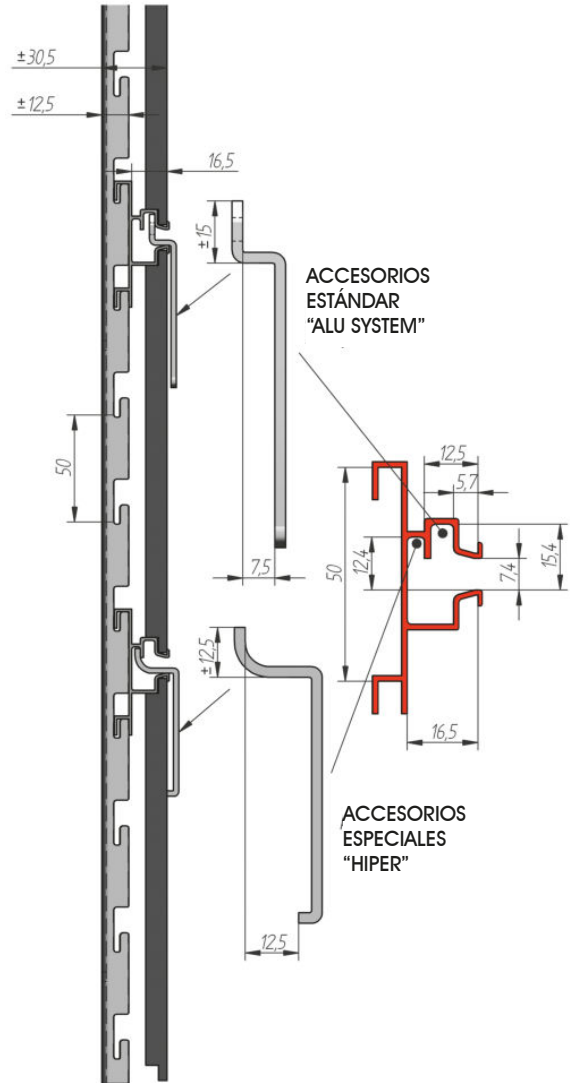
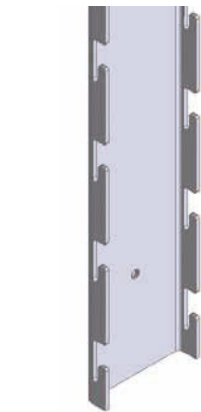

ACCESORIOS  
ESTÁNDAR  
"ALU SYSTEM"

ACCESORIOS  
ESPECIALES  
"HIPER"

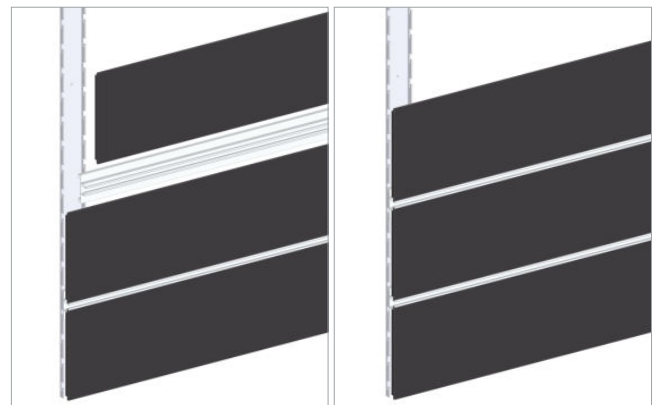
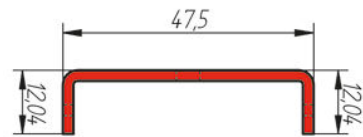

## LAMAS - DM

BLANCO	NEGRO	COLOR	PL. M
BLANC	NOIR	COULEUR	ALU. M
WHITE	BLACK	COLOR	ALU. M
BIANCO	NERO	COLORE	ALL. NAT
OB	ON	OP	O1

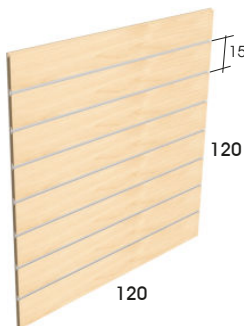

**LAMA PANEL DM**  
regata cada 15 cm.  
con perfil de aluminio "L" incluido

**PANNEAU RAINURÉ MDF**  
Fraisé 15 cm  
Profils en aluminium "L" inclus

**SLATWALL PANEL MDF**  
Milled: 15 cm  
Aluminium "L" profiles included

**PANNELLO DOGATO MDF**  
Fresato: 15 cm  
Profili "L" di alluminio inclusi

HAYA, hêtre, beech, acero  
BLANCO, blanc, white, blanco

\*477/12. Asia

\*432/12. EU

DM	120x120
	18mm €/u

\*o \*o \*o  
otros colores consultar cantidad minima 50 u.

## LAMA "DM" 120x120 cm

Regata cada 15 cm con perfil de aluminio

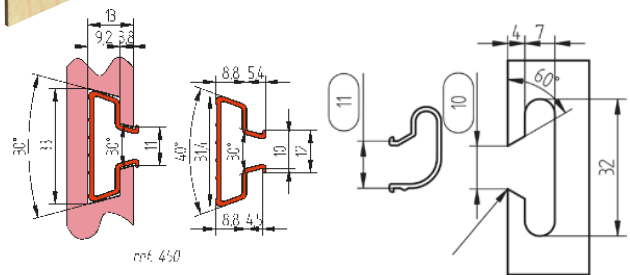
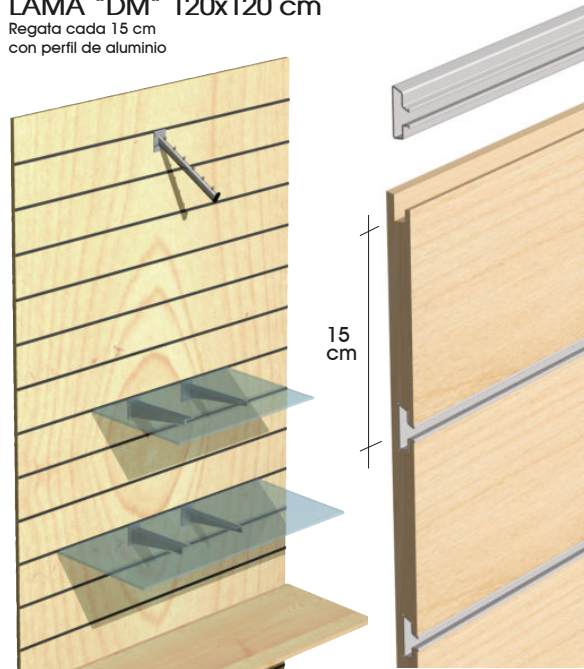

Las LAMAS tienen el terminal fresado para panelado continuo de paredes. La combinación de 2 LAMAS permite obtener una sola superficie de 2,4 x 1,2 m con 15 ranuras de aluminio, una cada 15 cm.



Fresa 450/F01

### PASO 1

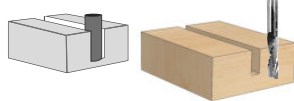

Fresa 450/F00

### PASO 2

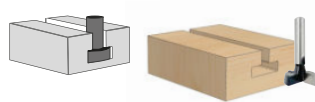

SE RECOMIENDA UTILIZAR AMBAS PARA PROLONGAR EL CICLO DE VIDA DE LA FRESA

UTILIZADAS CORRECTAMENTE SU CICLO DE VIDA SE PUEDE DUPLICAR



**FRESA "T" 31 mm**  
FRAISE EN "T" 31 mm  
"T" MILL 31 mm  
FRESA A "T" 31 mm  
**450/F00**

Al €/u

o



**FRESA DIÁMETRO Ø8**  
FRAISE DIAMÈTRE Ø8  
CUTTER DIAMETER Ø8  
DIAMETRO FRESA Ø8  
**450/F01**

Al €/u

o



**PERFIL DE ALUMINIO "T"**  
PROFIL D'ALUMINIUM "T"  
ALUMINIUM PROFILE "T"  
PROFILO DI ALLUMINIO "T"  
**450/240 BRUTO**  
**450/480 BRUTO**

Al €/u

o

o



**PERFIL DE ALUMINIO "L"**  
PROFIL D'ALUMINIUM "L"  
ALUMINIUM PROFILE "L"  
PROFILO DI ALLUMINIO "L"  
**\*451/120 BRUTO**

Al €/u

\*o

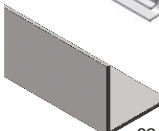

**ÁNGULO 20x20 mm**  
PROFIL EN "L" 20X20  
PROFIL "L" SHAPE 20X20  
PROFILO ANGOLARE 20X20  
**1651/1..**

Al €/m

o o o o

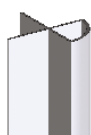

**PERFIL ESQUINERO**  
PROFIL ANGULAIRE  
ANGULAR PROFIL  
PROFILO ANGOLARE  
**\*421/1..**

Al €/m

\*o \*o \*o

LAMAS - ALUMINIO

BLANCO	NEGRO	COLOR	PL. M
BLANC	NOR	COULEUR	ALU. M
WHITE	BLACK	COLOR	ALU. M
BIANCO	NERO	COLORE	ALL. NAT
OB	ON	OP	O1

LAMA aluminio regata cada 75 mm

Rainure chaque 75 mm - Slot every 75 mm - Slot ogni 75 mm

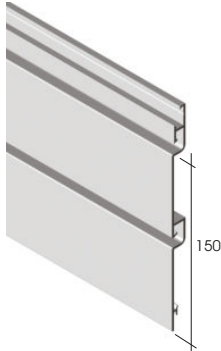

LAMA ALUMINIO "LISA"  
REGATA CADA 75 mm

Al	5 m	178x12,5	€/m
----	-----	----------	-----

PROFIL LAME D'ALUMINIUM  
Rainure chaque 75 mm

ALUMINIUM SLATWALL PROFILE  
Slot every 75 mm

PROFILO DOGATO ALLUMINIO  
Slot ogni 75 mm

427/1..

<input type="radio"/>	<input type="radio"/>	<input type="radio"/>	<input type="radio"/>
-----------------------	-----------------------	-----------------------	-----------------------

LAS LAMAS 427 Y 429 SE PUEDEN  
INTERCALAR ENTRE SI

Les profils 427 et 429 peuvent être intercalés entre eux  
The profiles 427 and 429 can be interspersed between them  
I profili 427 e 429 possono essere intervallati tra loro

LAMA aluminio regata cada 37,5 mm

Rainure chaque 37,5 mm - Slot every 37,5 mm - Slot ogni 37,5 mm

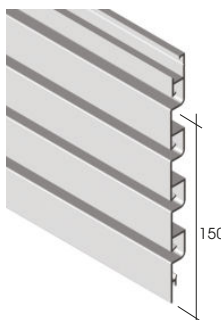

LAMA ALUMINIO,  
REGATA CADA 37,5 mm

Al	5 m	178x12,5	€/m
----	-----	----------	-----

PROFIL LAME D'ALUMINIUM  
Rainure chaque 37,5 mm

ALUMINIUM SLATWALL PROFILE  
Slot every 37,5 mm

PROFILO DOGATO ALLUMINIO  
Slot ogni 37,5 mm

429/1..

<input type="radio"/>	<input type="radio"/>	<input type="radio"/>	<input type="radio"/>
-----------------------	-----------------------	-----------------------	-----------------------

LAS LAMAS 427 Y 429 SE PUEDEN  
INTERCALAR ENTRE SI

Les profils 427 et 429 peuvent être intercalés entre eux  
The profiles 427 and 429 can be interspersed between them  
I profili 427 e 429 possono essere intervallati tra loro

REMATES Y SOPORTES



REMATE SUPERIOR  
PARA 427 Y 429

Al	5 m	30x12,5	€/m
----	-----	---------	-----

PROFIL SUPERIEUR DE FINITION

Pour 427 and 429

FINISHING UPPER PROFILE

For 427 and 429

PROFILO SUPERIORE DI FINITURA

Per 427 e 429

426/1..

<input type="radio"/>	<input type="radio"/>	<input type="radio"/>	<input type="radio"/>
-----------------------	-----------------------	-----------------------	-----------------------



PERFIL SOPORTE INFERIOR  
PARA 427 Y 429

Al	5 m	28x11	€/m
----	-----	-------	-----

PROFIL INFÉRIEUR DE SUPPORT

Pour 427 and 429

LOWER SUPPORT PROFILE

For 427 and 429

PROFILO INFERIORE DI SUPPORTO

Per 427 e 429

424/1..

<input type="radio"/>	<input type="radio"/>	<input type="radio"/>	<input type="radio"/>
-----------------------	-----------------------	-----------------------	-----------------------



ÁNGULO 15x15 mm

PROFIL EN "L" 15X15

PROFIL "L" SHAPE 15X15

PROFILO ANGOLARE 15X15

1650/1..

Al	6,4 m	15x15x1,5	€/m
----	-------	-----------	-----

<input type="radio"/>	<input type="radio"/>	<input type="radio"/>	<input type="radio"/>
-----------------------	-----------------------	-----------------------	-----------------------

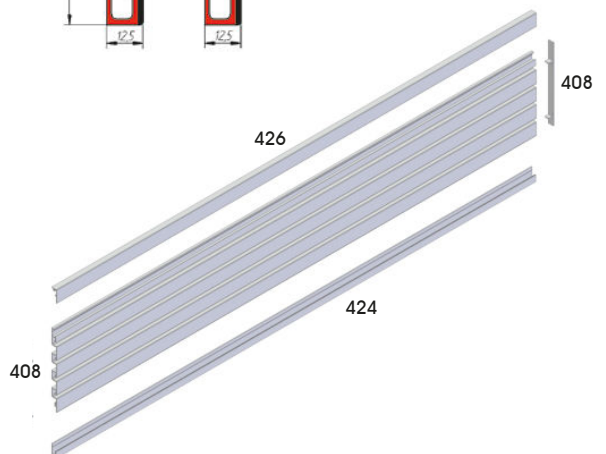
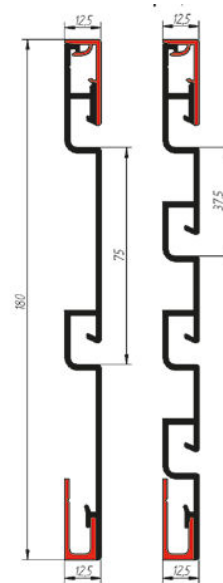
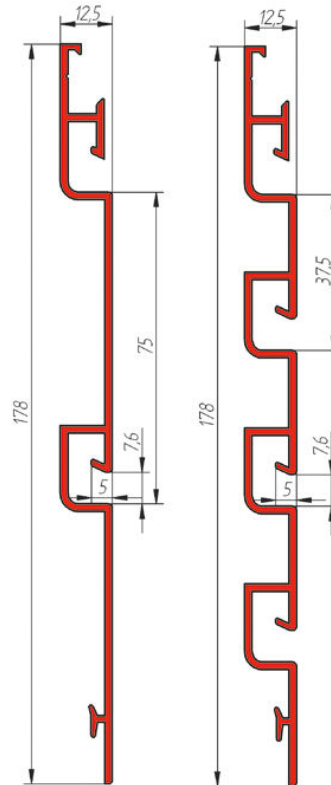

ACCESORIOS LAMAS

ACCESORIOS DE HIERRO

	CR. BRILLO CR. POLI BR. CHR. CR. ILLC.	BLANCO BLANC WHITE BIANCO	NEGRO NOIR BLACK NERO	COLOR COULEUR COLOR COLORE	32	OB	ON	OP
<b>GANCHO CROCHET HOOK BARRETTA</b> 418/X.. 10 cm 417/X.. 15 cm 446/X.. 20 cm 413/X.. 25 cm 414/X.. 30 cm								Fe €/u
<b>GANCHO PORTAPRECIO CROCHET PORTAPRIX HOOK LABEL-HOLDER BARRETTA PORTAPREZZO</b> 329/X.. 10 cm 326/X.. 15 cm 327/X.. 20 cm 328/X.. 25 cm					Fe	∞	382	€/u
<b>GANCHO CROCHET HOOK BARRETTA</b> 445/X.. 20 cm								Fe €/u
<b>GANCHO PORTAPRECIO CROCHET PORTAPRIX HOOK LABEL-HOLDER BARRETTA PORTAPREZZO</b> 447/X.. 20 cm					Fe	∞	382	€/u
<b>GANCHO CROCHET HOOK BARRETTA</b> *448/X.. 20 cm								Fe €/u
<b>GANCHO CROCHET HOOK BARRETTA</b> 441/X.. 20 cm 442/X.. 15 cm								Fe €/u
<b>GANCHO PORTAPRECIO CROCHET PORTAPRIX HOOK LABEL-HOLDER BARRETTA PORTAPREZZO</b> 381/X.. 15 cm 380/X.. 25 cm					Fe	∞	382	€/u
<b>PORTAPRECIO PORTAPRIX LABELHOLDER PORTAPREZZO</b> 382/009					plas	40x50 mm		€/u
<b>BLOQUEO GANCHO BLOCAGE BROCHE HOOK SECURITY LOCK BLOCCO SICUREZZA GANCIO</b> 373/00N					plas	∅6 mm		€/u
<b>BLOQUEO GANCHO DOBLE BLOCAGE BROCHE DOUBLE DOUBLE HOOK SECURITY LOCK BLOCCO GANCIO DOPPIO</b> 383/00N					plas	∅6 mm		€/u
<b>IMÁN ESPECIAL DESBLOQUEO UNLOCK MAGNET UNLOCK MAGNET MAGNETE DI SBLOCCO</b> 384/000					plas	373-383/00N		€/u
<b>CARTELA ESTANTE VIDRO SUPPORT TABLETTES VERRE GLASS SHELF BRACKET MENSOLA RIPIANO VETRO</b> 488/X.. derecha droite/right/destra 487/X.. izquierda gauche/left/sinistra					Fe	∩	8-10 mm	€/u
<b>CARTELA ESTANTE VIDRO SUPPORT TABLETTES VERRE GLASS SHELF BRACKET MENSOLA RIPIANO VETRO</b> 482/X.. derecha droite/right/destra 483/X.. izquierda gauche/left/sinistra					Fe	∩	8-10 mm	€/u



**CARTELA ESTANTE MADERA SUPPORT TABLETTES BOIS WOOD SHELF BRACKET MENSOLA RIPIANO LEGNO**  
489/X.. derecha droite/right/destra  
490/X.. izquierda gauche/left/sinistra

**CARTELA ESTANTE MADERA SUPPORT TABLETTES BOIS WOOD SHELF BRACKET MENSOLA RIPIANO LEGNO**  
480/X.. derecha droite/right/destra  
484/X.. izquierda gauche/left/sinistra

**PERROQUET INCLINADO PERROQUET INCLINÉE SLOPING ARM APPENDERIA INCLINADA**  
465/X..

**PERROQUET PLANO PENDERIE FRONTAL STRAIGHT ARM APPENDERIA FRONTALE**  
472/X..

**PERROQUET PLANO "Z" PENDERIE FRONTAL "Z" STRAIGHT ARM "Z" APPENDERIA FRONTALE "Z"**  
469/X..

**BARRA PENDERIE BARRE PENDERIE HANGING BAR BARRA APPENDERIA**  
459/X..

**SOPORTE CORBATERO SUPPORT TIE RACK SUPPORT PORTE-CRAVATES SUPPORTO PORTACRAVATTE**  
\*473/X..

**SOPORTE CASCO HELMET SUPPORT SUPPORT CASQUE MOTO SUPPORTO CASCO**  
462/X..

**SOPORTE PELOTA BALL SUPPORT SUPPORT DE BALLON SUPPORTO PALLA**  
461/X..

**ESTANTE REJILLA FLAT GRID SHELF ÉTAGÈRE PLAN DE GRILLE RIPIANO GRIGLIA**  
\*464/X..

**CESTA REJILLA GRID BASKET PANIER DE GRILLE CESTINO GRIGLIA**  
\*463/X..

**SOPORTE CALZADO SOUTIEN CHAUSSENT FOOTWEAR SUPPORT SUPPORTO CALZATURE**  
491/X..

	CR. BRILLO CR. POLI BR. CHR. CR. ILLC.	BLANCO BLANC WHITE BIANCO	NEGRO NOIR BLACK NERO	COLOR COULEUR COLOR COLORE	32	OB	ON	OP
					Fe	∩	19 mm	€/u
					Fe		250 mm	€/u
					Fe		300 mm	€/u
					Fe		300 mm	€/u
					Fe		350 mm	€/u
					Fe	90x30 cm	12 kg/u	€/u
					Fe	∅ 342 mm		€/u
					Fe	∅ 116 mm		€/u
					Fe	∅ 130 mm		€/u
					Fe	600x310 mm		€/u
					Fe	600x310 mm		€/u
					Fe	250x100 mm		€/u

BLANCO BLANC WHITE BIANCO	NEGRO NOR BLACK NERO	COLOR COULEUR COLOR COLORE	PL. M ALU. M ALU. M ALL. NAT
OB	ON	OP	O1

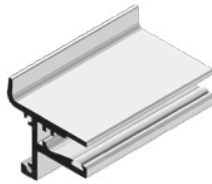

LAMA ALUMINIO  
PROFIL LAME D'ALUMINIUM  
ALUMINIUM SLATWALL PROFILE  
PROFILO DOGATO ALLUMINIO

\*362/1.. \*o \*o \*o \*o

Junta goma incluida  
Joint en caoutchouc inclus  
Rubber gasket included  
Giunta di gomma inclusa

Al	6-8 mm	€/m
∞ 361/1...	5 m	

### Perfil aluminio 362

- Admite estante de vidrio de 6 y 8 mm.  
(SE RECOMIENDA VIDRIO DE SEGURIDAD).  
- Admite iluminación LED en el canal del perfil.

Aluminum profile, 362  
- Allows glass shelf 6 and 8 mm thickness.  
(SAFETY GLASS IS RECOMMENDED)  
- Allows LED lighting.

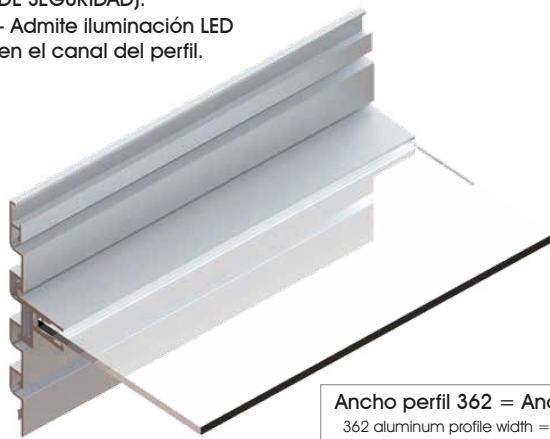

Ancho perfil 362 = Ancho vidrio  
362 aluminum profile width = Glass width  
Largeur du profil 362 = Largeur de verre  
Larghezza profilo 362 = Larghezza di vetro

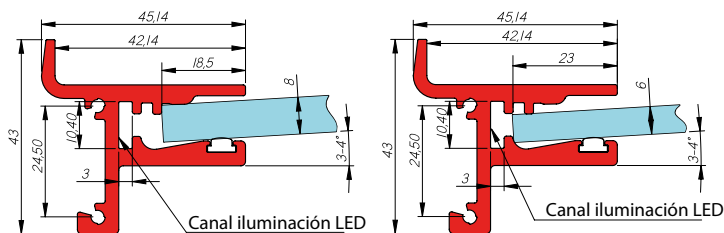

### ACCESORIOS DE ALUMINIO



PERROQUET PLANO  
PENDERIE FRONTAL  
STRAIGHT ARM  
APPENDERIA FRONTALE  
\*394/001

Al	325 mm	€/u
----	--------	-----

O1

PERROQUET INCLINADO  
PERROQUET INCLINÉE  
SLOPING ARM  
APPENDERIA INCLINADA  
\*395/001

Al	315 mm	€/u
----	--------	-----

\*o

### ACCESORIOS DE PLÁSTICO

PLÁSTICO PLASTIQUE PLASTIC PLASTICA
O9

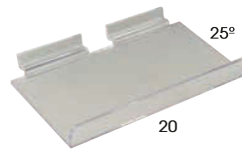

ESTANTE INCLINADO 25°  
TABLETTE INCLINÉ  
SHELF INCLINED 25°  
RIPIANO INCLINATO 25°  
\*435/009

plas	200x100
------	---------

transp.	€/u
---------	-----

\*o

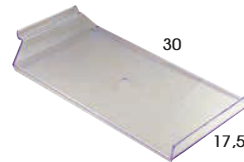

SOPORTE GORRA  
TABLETTE CHAPEAU  
HAT SHELF  
MENSOLA CAPPELLO  
\*452/009

plas	175x300
------	---------

transp.	€/u
---------	-----

\*o



PERROQUET PARA BOLSOS  
PERROQUET POUR SACS  
ARM FOR HANGING BAGS  
APPENDERIA PER BORSE  
\*443/009

plas	370 mm
------	--------

transp.	€/u
---------	-----

\*o



SOPORTE LIBROS, ETC.  
SUPPORT LIVRE DROITE  
BOOK HOLDER RIGHT  
SUPPORTO LIBRO DESTRA  
\*439/009 derecha

plas	
------	--

transp.	€/u
---------	-----

\*o



SOPORTE LIBROS, ETC.  
SUPPORT LIVRE GAUCHE  
BOOK HOLDER LEFT  
SUPPORTO LIBRO SINISTRA  
\*440/009 izquierda

plas	
------	--

transp.	€/u
---------	-----

\*o

**PARALELO 384**

Empotrable, fijación a panel para estantes de 5, 6 mm ó 8 mm  
Peso max. recomendado: 20 kg/ml (ver instrucciones)

ENCASTRÉ, MONTAGE SUR PANNEAU  
TABLETTE 5, 6 ou 8 mm  
POIDS MAX. RECOMMANDÉE: 20 kg / ml  
(VOIR LES INSTRUCTIONS)

EMBEDDED, PANEL MOUNTING  
SHELF 5, 6 mm or 8 mm  
MAX. RECOMMENDED: 20 kg / ml  
(SEE INSTRUCTIONS)

A INCASSO, MONTAGGIO A PANNELLO  
SHELF 5, 6 O 8 mm  
PESO MASS. CONSIGLIATO:  
20 kg / ml (VEDI ISTRUZIONI)

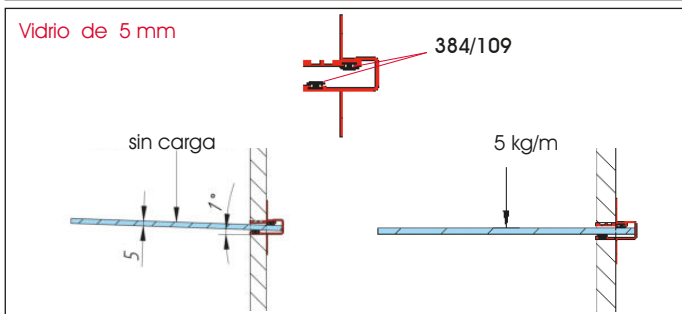
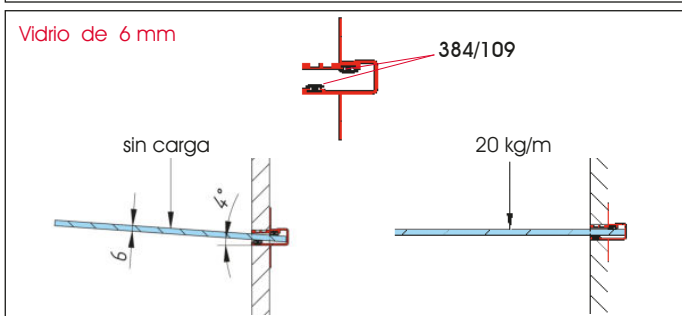
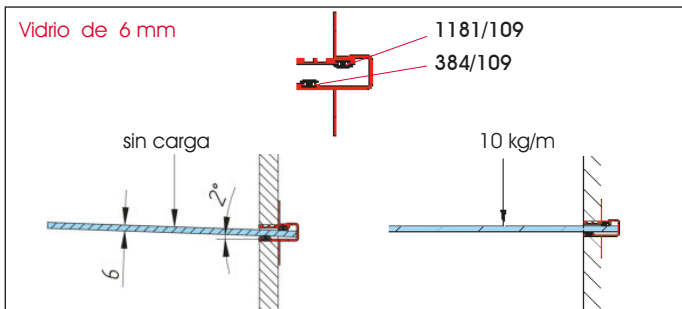
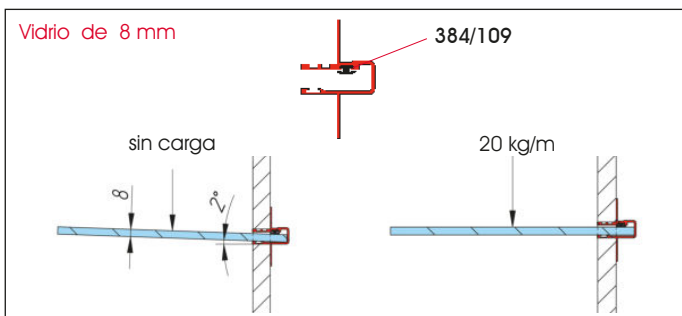

**MONTAJE**

**MONTAGE, MOUNTING, MONTAGGIO**

Debido a la deformación de las gomas por acción del peso soportado por el estante, se recomienda combinar distintos espesores de vidrio+gomas en relación al peso previsto.  
NOTA: Se recomienda utilizar estantes de vidrio de seguridad (según la normativa en espacios públicos y para una mayor resistencia).

*En raison de la déformation du caoutchouc par l'action du poids supporté par le tablette, il est recommandé de combiner différentes épaisseurs de verre + caoutchouc en rapport de poids attendus.*  
NOTE: Nous vous recommandons d'utiliser tablettes en verre de sécurité (en vertu des règles dans les espaces publics et pour plus de solidité).

*Due to deformation of the rubbers by the action of weight supported by the shelf, it is recommended to combine various glass thicknesses + rubbers depending on the weight expected.*  
NOTE: We recommend using safety glass shelves (under the rules in public spaces and for greater resistance).

*A causa della deformazione delle gomme per l'azione del peso sostenuto dal ripiano, si consiglia di combinare vari spessori vetro + gomme in relazione al peso previsto.*  
NOTE: Si consiglia utilizzare ripiani di vetro di sicurezza (nel rispetto delle norme in spazi pubblici e per una maggior resistenza).

Para un estante de 80 cm (max. recomendado):  
Pour une étagère de 80 cm (max. recommandé): 80 cm  
For a shelf 80 cm long (max. recommended): 80cm  
Per un ripiano di 80 cm di lunghezza (massimo raccomandato): 80 cm

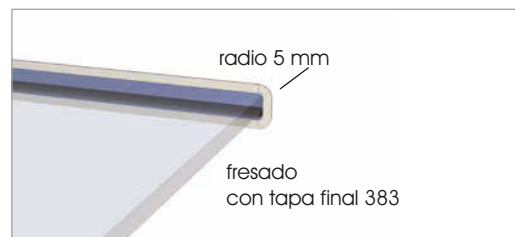
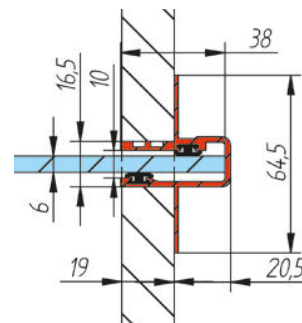

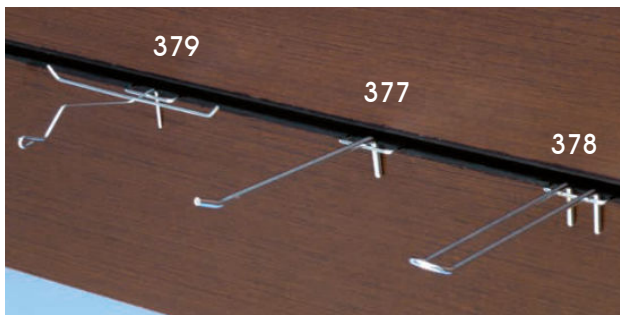
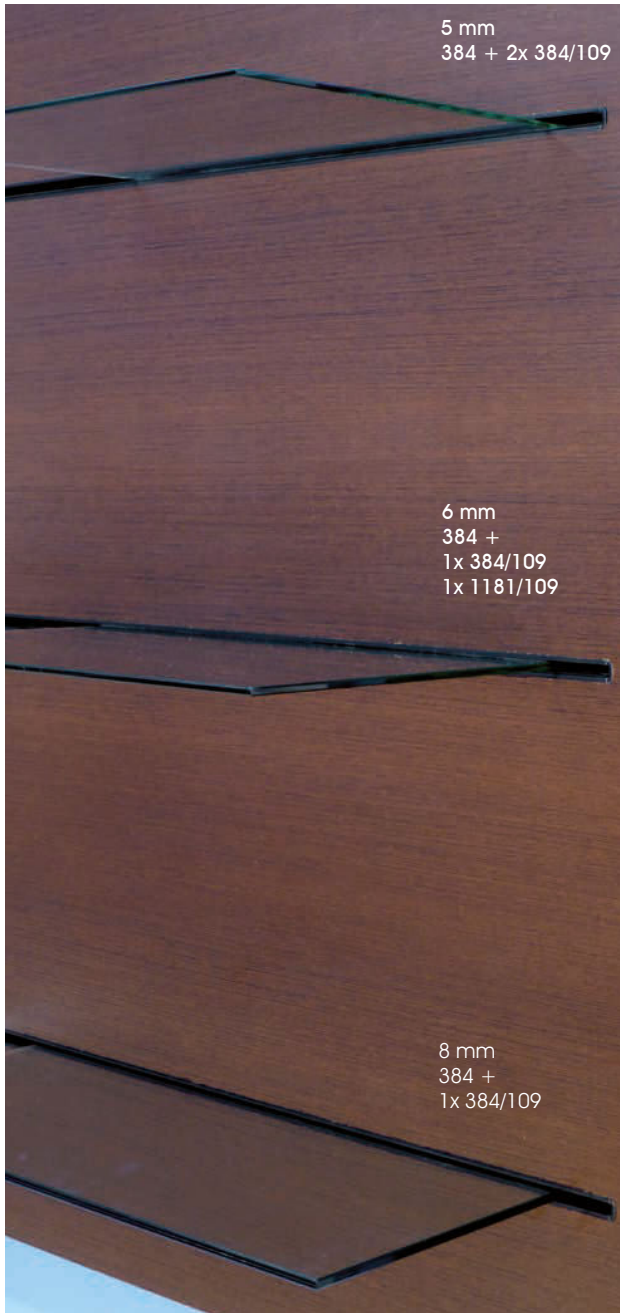

**ACCESORIOS**

PL. M	COLOR	BLANCO	NEGRO	OR. BRILLO
ALU. M	COULEUR	BLANC	NOIR	OR. POLI
ALL. M	COLOR	WHITE	BLACK	BR. CHR
ALL. NAT	COLORE	BIANCO	NERO	OR. LUC.
01	0P	0B	0N	32

	PERFIL INVISIBLE PROFIL D'ALUMINIUM ALUMINIUM PROFILE PROFILO DI ALLUMINIO <b>384/1..</b>	Al	5 m	5/6/8 mm	∞ 384/1181
	GOMA DURA CAOUTCHOUC DUR HARD RUBBER GOMMA DURA <b>384/109</b>				plas ∞ 384 €/m
	GOMA BLANDA CAOUTCHOUC SOUPLE SOFT RUBBER GOMMA MORBIDA <b>1181/109</b>				plas ∞ 384 €/m
	TAPA FINAL CABOCHON profil 384 END-CAP 384 profile COPRITESTA profilo 384 <b>383/OOP</b> GRIS <b>383/TON</b> NEGRO				plas ∞ 384 €/u
	GANCHO BROCHE HOOK BARRETTA <b>*377/032</b> 20 cm				Fe €/u
	GANCHO SEGURIDAD DOUBLE BROCHE DOUBLE HOOK BARRETTA DOPPIA <b>*378/032</b> 20 cm				Fe €/u
	GANCHO GAFAS SUPPORT FOR GLASSES SUPPORT POUR LUNETTES BARRETTA PER OCCHIALI <b>*379/032</b>				Fe €/u

**PERFIL PARALELO MAXI 389**

- Admite estante de vidrio de 8 mm **SE RECOMIENDA VIDRIO DE SEGURIDAD**

- Sistema machihembrado
- Peso max. admitido: 30 kg/ml
- Admite iluminación LED

LAMA aluminium INVISIBLE 389  
- Permet étagère en verre 8 mm d'épaisseur  
Verre de sécurité est recommandé  
- montage panneau à emboîtement  
- Max. poids admis: 25 kg / ml  
- Permet l'éclairage LED

LAMA aluminium INVISIBLE 389  
- Allows glass shelf 8 mm thick  
Safety glass is recommended  
- Socket joint  
- Max. admitted weight 30 kg / ml  
- Allows LED lighting

LAMA alluminio INVISIBLE 389  
- ammette ripiani in vetro 8 mm  
Si raccomanda l'uso di vetro sicurizzato  
- Sistema incastro  
- Peso massimo ammesso: 30 kg/ml  
- Ammette LEDs

	PERFIL INVISIBLE PARED "MAXI"	BRUTO BRUT GREZZO <b>00</b>
	LAMA ALUMINIO PROFIL D'ALUMINIUM ALUMINIUM PROFILE PROFILO DI ALLUMINIO NO COMPATIBLE con acc. 385, 386, 387, 388. <b>*389/100</b>	Al
		8 mm
		30kg/m
		€/m
		*o

OPTI 3

PERFIL INVISIBLE PARA ESTANTES Y ACCESORIOS DE 3MM DE ESPESOR

SISTEMA MACHIHEMBRADO  
SYSTÈME EMBOÎTEMENT  
SOCKET JOINT SYSTEM  
SISTEMA A INCASTRO

BLANCO	NEGRO	COLOR	PL. M
BLANC	NOIR	COULEUR	ALU. M
WHITE	BLACK	COLOR	ALU. M
BIANCO	NERO	COLORE	ALL. NAT

OB	ON	OP	O1
----	----	----	----



PERFIL INVISIBLE PARA ESTANTES DE 3 MM DE ESPESOR  
PROFIL INVISIBLE POUR ÉTAGÈRES 3 MM D'ÉPAISSEUR  
INVISIBLE PROFILE FOR SHELVES 3 MM THICK  
PROFILO INVISIBLE PER RIPIANI DI 3 MM DI SPESSORE

Al	5 m	€/m
6/8 mm		

360/1..

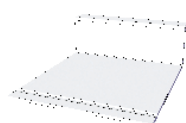

ESTANTE EXTRUSIONADO 3 MM  
SUPPORT-TABLETTE 3MM  
FOLDED BRACKET-SHELF 3 MM  
MENSOLA-RIPIANO PIEDATA 3 MM  
387/0.. 190MM  
(POSIBILIDAD DE CORTE A MEDIDA BAJO PEDIDO)

Al	190x190x50 mm	€/u
----	---------------	-----

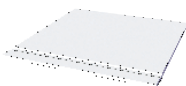

BANDEJA SIMPLE 3 MM  
SUPPORT-TABLETTE 3MM  
BRACKET-SHELF 3 MM  
MENSOLA-RIPIANO 3 MM  
388/0..

Fe	190x210 mm	€/u
----	------------	-----

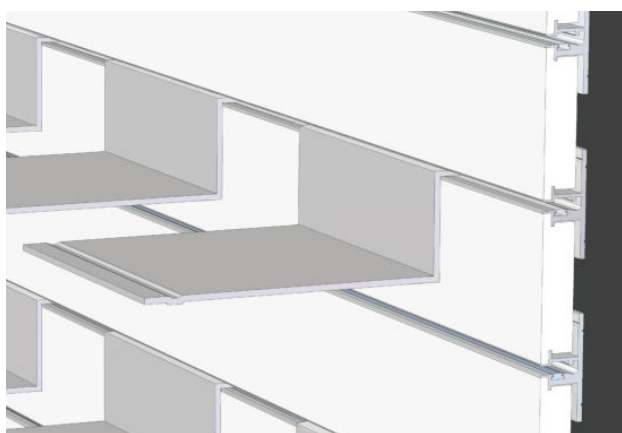
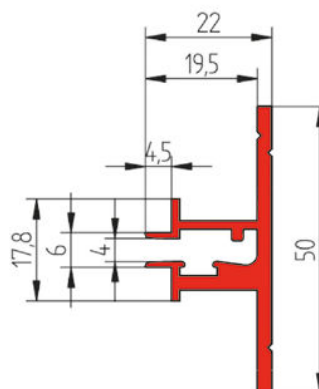

INFORMACIÓN TÉCNICA OPTI-3

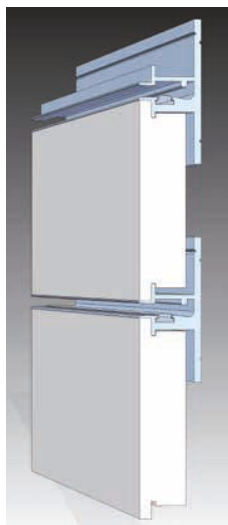

Madera 16 mm



Madera 19 mm

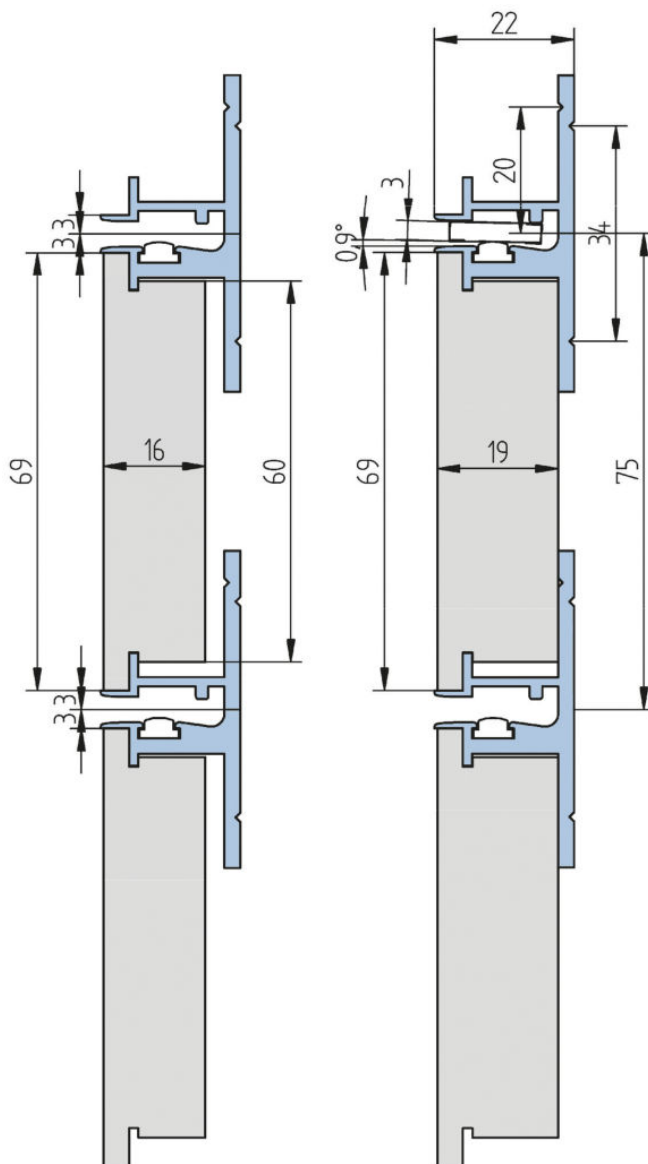
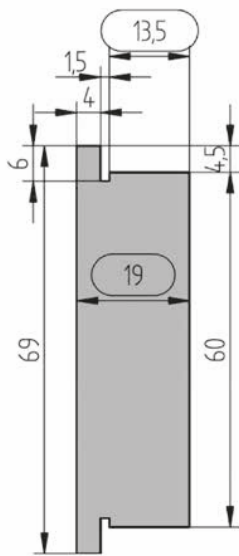
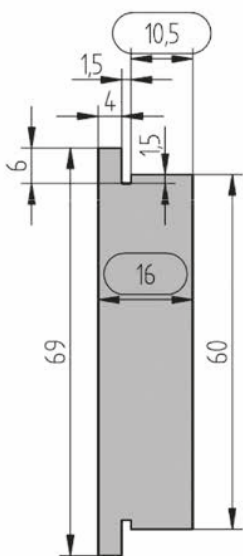

Madera 19 mm

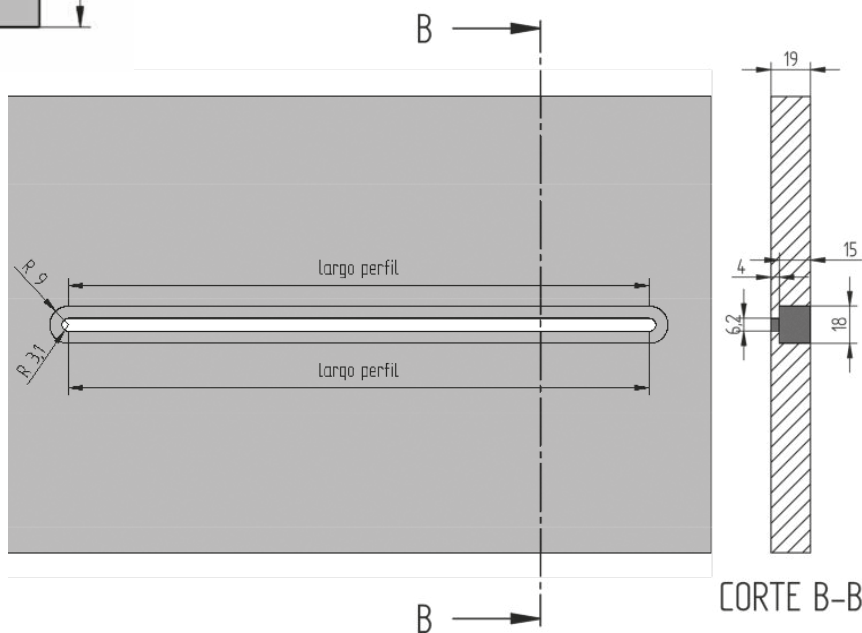





instal.

# MULTILAMAS Y VERTICAL

SISTEMAS DE ACCESORIOS COMPATIBLES

## MULTILAMA

MONTAJE  
INFORMACIÓN TÉCNICA  
COMPONENTES  
REMATE LATERAL  
COMPONENTES  
ACCESORIOS SOLO PARA

MULTILAMA  
ANGULOS Y "US"

## VERTICAL

INFORMACIÓN TÉCNICA  
MONTAJE  
COMPONENTES  
GÓNDOLAS  
ACCESORIOS GÓNDOLAS  
ACCESORIOS COMUNES

MULTILAMA





## MONTAJE

1. Colocar las cremalleras 400 a una distancia de 30-40 cm entre ellas, dependiendo de la carga a soportar. Con paredes de Pladur se recomienda fijar las cremalleras a los montantes estructurales de la misma.
2. Se recomienda evitar colocar los accesorios con peso en la ranura de unión entre una lama y la otra.

1. Placing the racks 400 at a distance of 30-40 cm between them, depending on the load to be supported. With plasterboard walls is recommended to set the racks to the same structural uprights.

2. It is recommended to avoid placing accessories in the slot between 2 profiles.

1. Placer les crémaillères 400 à une distance de 30 à 40 cm entre eux, en fonction de la charge à supporter. Avec des murs en plaques de plâtre est recommandé de fixer les crémaillères pour les mêmes montants de structure.

2. Il est recommandé d'éviter de placer le poids de les accessoires en la joint de deux profils.

1. Montare i profili cremagliera a una distanza di 30-40 cm fra loro, in funzione del peso che deve sopportare. Con pareti di cartongesso, si raccomanda fissare i montanti direttamente alla struttura della stessa parete.

2. Si raccomanda evitare la collocazione degli accessori nella ranura corrispondente all'unione di 2 profili.

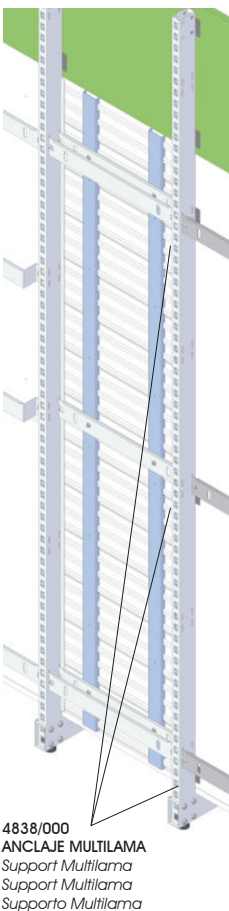

### Solución con MULTILAMA

Solution avec MULTILAMA  
Solution with MULTILAMA  
Soluzione con MULTILAMA



MONTAJE FRONTAL  
montage frontal  
front mounting  
montaggio frontale

1650/1..  
REMATE ÁNGULO 15X15  
profil lateral de finition  
lateral finishing profile  
profilo laterale di finitura

1651/1..  
REMATE ÁNGULO 20X20  
profil lateral de finition  
lateral finishing profile  
profilo laterale di finitura



ESCONDIDO  
caché  
hidden  
nascosto

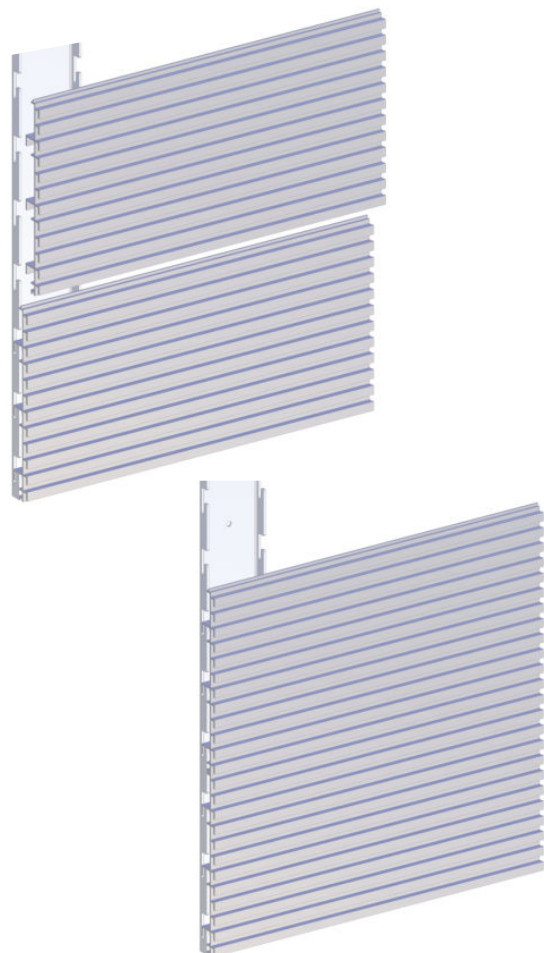

4838/000  
ANCLAJE MULTILAMA  
Support Multilama  
Support Multilama  
Supporto Multilama

## INFORMACIÓN TÉCNICA MULTILAMA

**MULTILAMA aluminio regata cada 12,5 mm**  
 Rainure chaque 12,5 mm - Slot every  
 12,5 mm - Slot ogni 12,5 mm

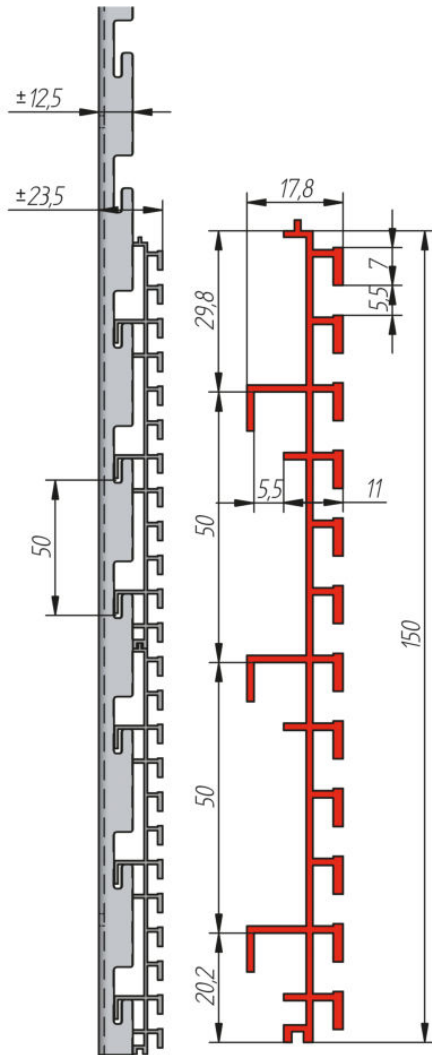

## REMATE LATERAL

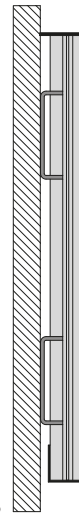
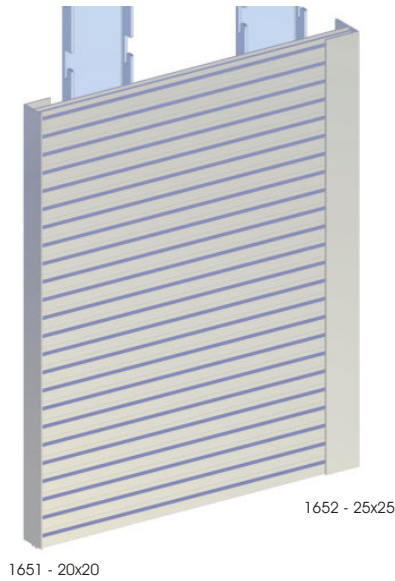

**MONTAJE FRONTAL**  
 montage frontal  
 front mounting  
 montaggio frontale  
 1652 - 25x25  
 pegada por delante

**ESCONDIDO**  
 caché  
 hidden  
 nascosto  
 1651 - 20x20  
 pegada por atrás

## GUÍA 400



COMPONENTES

MULTILAMA aluminio regata cada 12,5 mm  
Rainure chaque 12,5 mm - Slot every 12,5 mm - Slot ogni 12,5 mm

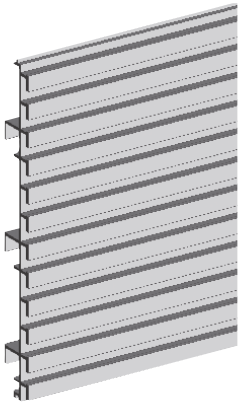

MULTILAMA ALUMINIO  
12 CANALES (12,5 MM)  
PROFIL LAME D'ALUMINIUM  
12 rainures chaque 12,5 mm  
ALUMINIUM SLOT/WALL PROFILE  
12 Slots every 12,5 mm  
PROFLO DOGATO ALLUMINIO  
12 ranure ogni 12,5 mm  
401/1..

Al	5 m	∞	400	€/m
----	-----	---	-----	-----

Guía pared  
MULTILAMA

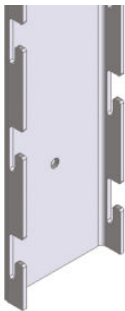

CREMALLERA PARED  
PARA PERFILES 403...403  
CRÉMAILLÈRE MUR  
Avec profils 403 et 401  
WALL RACK  
for profiles 403 y 401  
CREMAGLIERA PARETE  
con profili 403 e 401  
400/334

ZINCADO  
PL. ZNK  
ZINK PL.  
ZINCATO  
34

Al	3 m	∞	401-403	€/m
----	-----	---	---------	-----

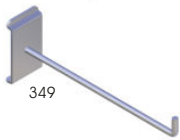

GANCHO  
CROCHET  
HOOK  
GANCIO  
332/0.. 10 cm  
352/0.. 15 cm  
349/0.. 20 cm  
353/0.. 25 cm  
350/0.. 30 cm

CR. BRILLO  
CHR. FOI  
BR. CHR.  
CR. ILLC.  
32

Fe	∞	401	€/u
----	---	-----	-----

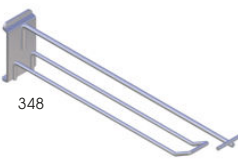

GANCHO PORTAPRECIO  
CROCHET PORTAPRIX  
HOOK LABEL-HOLDER  
GANCIO PORTAPREZZO  
334/0.. 15 cm  
338/0.. 20 cm  
348/0.. 25 cm

Fe	∞	401-382	€/u
----	---	---------	-----



PORTAPRECIO  
PORTAPRIX  
LABELHOLDER  
PORTAPREZZO  
382/009

plas	40x50 mm	€/u
------	----------	-----



BLOQUEO GANCHO  
BLOCAGE BROCHE  
HOOK SECURITY LOCK  
BLOCCO SICUREZZA GANCIO  
373/00N

plas	∅6 mm	€/u
------	-------	-----



BLOQUEO GANCHO DOBLE  
BLOCAGE BROCHE DOUBLE  
DOUBLE HOOK SECURITY LOCK  
BLOCCO GANCIO DOPPIO  
383/00N

plas	∅6 mm	€/u
------	-------	-----



IMÁN ESPECIAL DESBLOQUEO  
UNLOCK MAGNET  
UNLOCK MAGNET  
MAGNETE DI SBLOCCO  
384/000

plas	373-383/00N	€/u
------	-------------	-----

ACCESORIOS SOLO  
PARA MULTILAMA

ACCESSOIRES SEULEMENT POUR MULTILAMA  
ACCESSORIES ONLY FOR MULTILAMA  
ACCESSORI SOLO PER MULTILAMA

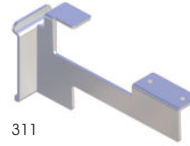

CARTELA ESTANTE MADERA  
SUPPORT TABLETTE BOIS  
WOOD SHELF BRACKET  
MENSOLA RIPIANO LEGNO  
310/0.. derecha  
droite/right/destra  
311/0.. izquierda  
gauche/left/sinistra

OB	ON	OP	32
----	----	----	----

Fe	19 mm	∞	401	€/u
----	-------	---	-----	-----

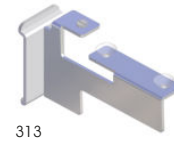

CARTELA ESTANTE VIDRO  
SUPPORT TABLETTE VERRE  
GLASS SHELF BRACKET  
MENSOLA RIPIANO VETRO  
312/0.. derecha  
droite/right/destra  
313/0.. izquierda  
gauche/left/sinistra

Fe	8-10 mm	∞	401	€/u
----	---------	---	-----	-----

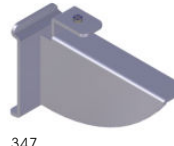

CARTELA ESTANTE VIDRO  
SUPPORT TABLETTE VERRE  
GLASS SHELF BRACKET  
MENSOLA RIPIANO VETRO  
346/0.. derecha  
droite/right/destra  
347/0.. izquierda  
gauche/left/sinistra

Fe	8-10 mm	∞	401	€/u
----	---------	---	-----	-----

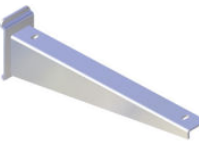

CARTELA ESTANTE MADERA  
SUPPORT TABLETTE BOIS  
WOOD SHELF BRACKET  
MENSOLA RIPIANO LEGNO  
344/0.. derecha  
droite/right/destra  
340/0.. izquierda  
gauche/left/sinistra

Fe	250 mm	∞	401	€/u
----	--------	---	-----	-----

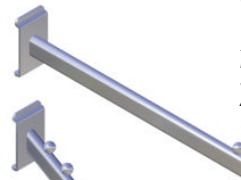

PERROQUET PLANO  
PENDERIE FRONTAL  
STRAIGHT ARM  
APPENDERIA FRONTALE  
343/0..

Fe	300 mm	∞	401	€/u
----	--------	---	-----	-----



PERROQUET INCLINADO  
PENDERIE INCLINÉE  
SLOPING ARM  
APPENDERIA INCLINADA  
342/0..

Fe	300 mm	∞	401	€/u
----	--------	---	-----	-----

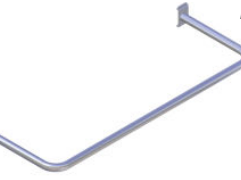

BARRA PENDERIE  
BARRE PENDERIE  
HANGING BAR  
BARRA APPENDERIA  
351/0..

Fe	90x30 cm	∞	401	€/u
----	----------	---	-----	-----

12 kg/u

ÁNGULOS Y "US"

PROFILES "L" ET "U" / "L" AND "U" PROFILES /  
PROFILI "L" E "U"



ÁNGULO 20x20 mm  
PROFIL EN "L" 20X20  
PROFIL "L" SHAPE 20X20  
PROFILO ANGOLARE 20X20  
1651/1..

PL. M ALU. M ALL. NAT	ORO DORÉ DOR. OP	M BLANC M WHITE BIANCO	NEGRO NOIR BLACK NERO	COLOR COULEUR COLOR COLORE
-----------------------------	------------------------	------------------------------------	--------------------------------	-------------------------------------

Al	5 m	20x20x1 mm	€/m
----	-----	------------	-----



ÁNGULO 25x25 mm  
PROFIL EN "L" 25X25  
PROFIL "L" SHAPE 25X25  
PROFILO ANGOLARE 25X25  
1652/1..

Al	5 m	25x25x1,5 mm	€/m
----	-----	--------------	-----

## VERTICAL

### CARACTERÍSTICAS

- Sistema modular que se adapta a cualquier medida entre montantes
- permite montantes individuales
- Estantes de madera y vidrio de 20 a 35 cm de fondo
- Se puede pintar en cualquier color

### CARACTÉRISTIQUES - FEATURS - CARATTERISTICHE

- Système modulaire réglable pour chaque distance entre montants
- Modular system adjustable for each distance between uprights
- Sistema modulare regolabile per ogni distanza fra piantane

- Permet tube-crémallères individuels
- allows individual uprights
- permette piantane individuali

- Tablettes en bois et verre de 20 à 35 cm de profondeur
- Wooden and glass shelves of 20-35 cm deep
- Ripiani di legno e vetro da 20 a 35 cm di fondo

- Il peut être peint dans toutes les couleurs
- It can be painted in any color
- si può verniciare in qualsiasi colore





INFORMACIÓN TÉCNICA VERTICAL

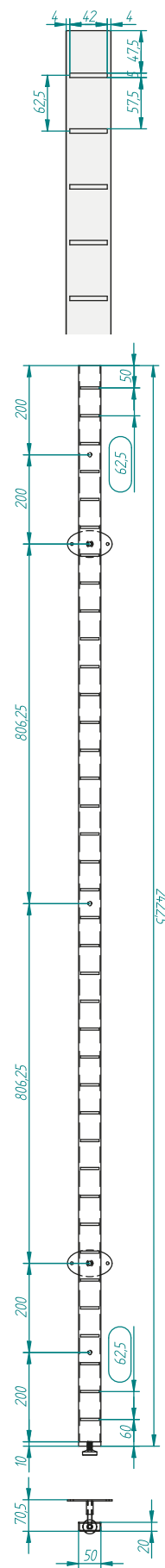

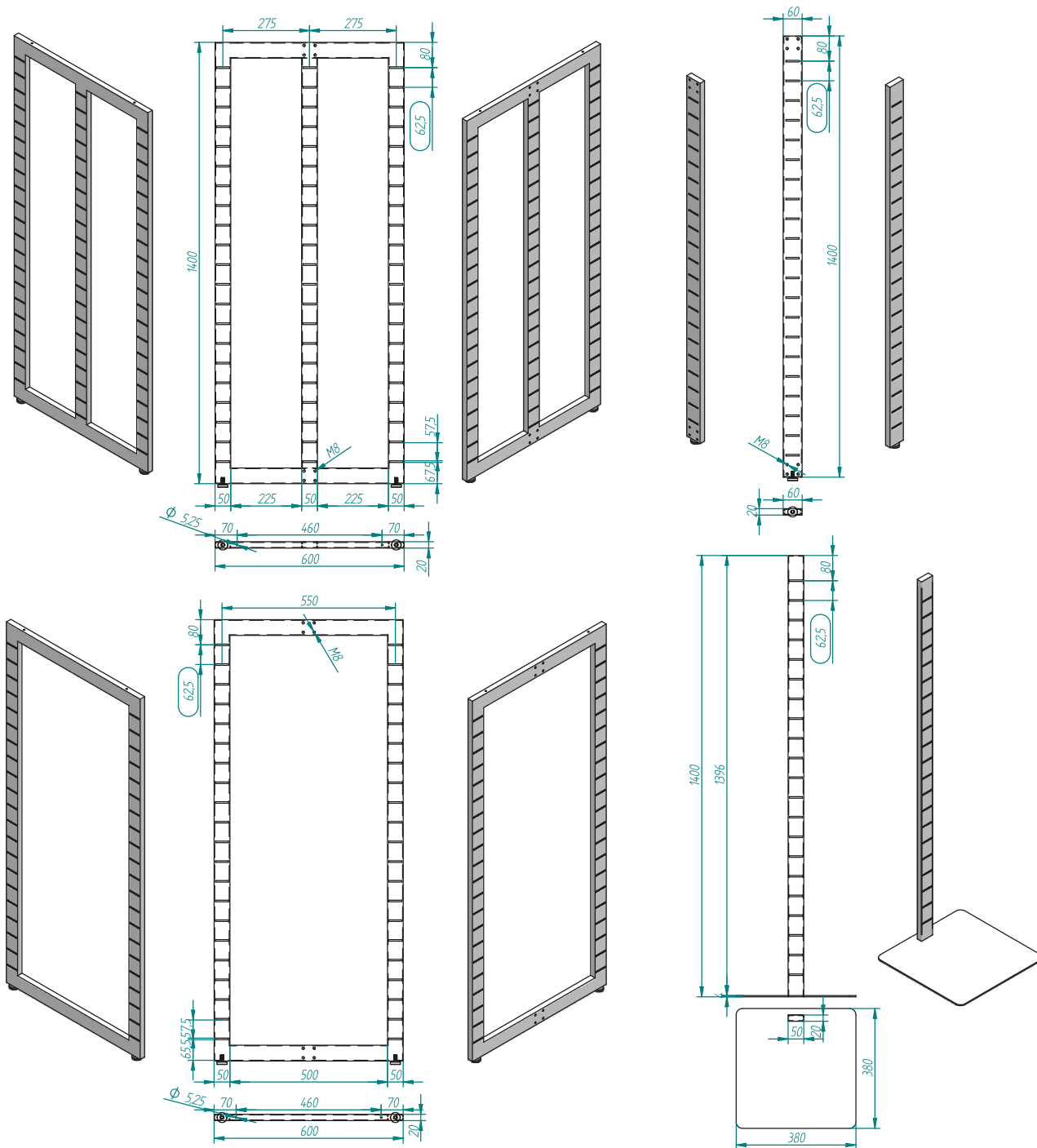
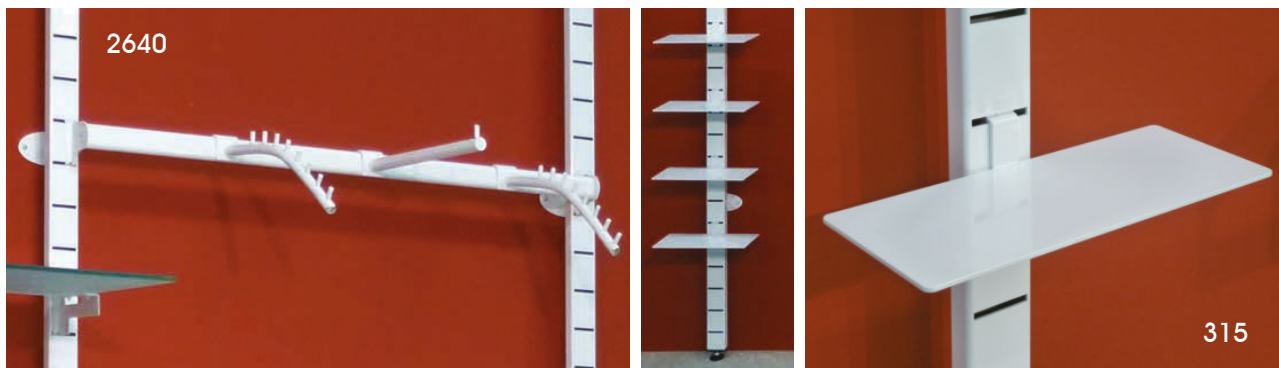

## MONTAJE VERTICAL

### 1. Montaje a pared

Sistema modular que se adapta a cualquier medida de eje entre montantes.

**MONTAGE MURAL** Système modulaire réglable pour chaque distance entre montants

**WALL MOUNTING** Modular system adjustable for each distance between uprights

**MONTAGGIO A PARETE** Sistema modulare regolabile per ogni distanza fra piantane

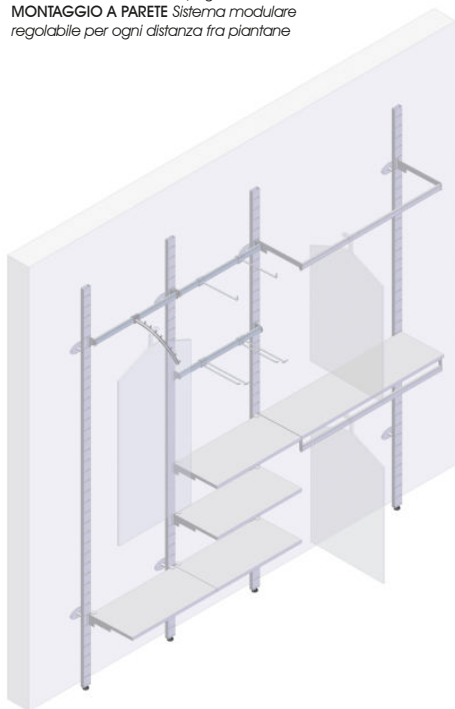

### 2. Montaje a pared

Total libertad de combinación compositiva con estantes repartidos entre montantes o estantes individuales

**MONTAGE MURAL** tablettes divisées entre les poteaux ou étagères individuelles

**WALL MOUNTING** shelves divided between uprights or individual shelves

**MONTAGGIO A PARETE** ripiani condivisi fra piantane o scaffalature individuali



### 3. Montaje a pared

Posibilidad de usar montantes individuales con accesorios del sistema Multilamas.

**MONTAGE MURAL** Permet tube-crémaillères individuels avec accessoires MULTILAMA

**WALL MOUNTING** allows individual uprights with MULTILAMA fittings

**MONTAGGIO A PARETE** permette piantane individuali con accessori MULTILAMA

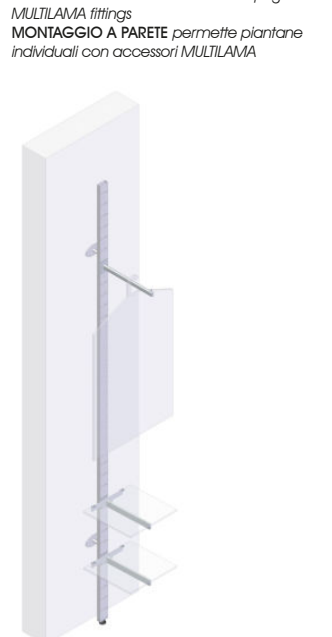

### 4. Display autoportante

Múltiplas combinaciones para hacer góndolas

*Multiple combinations pour displays autoportantes*

*Multiple combinations for displays self-supporting*

*Combinazioni multiple per displays autoportanti*

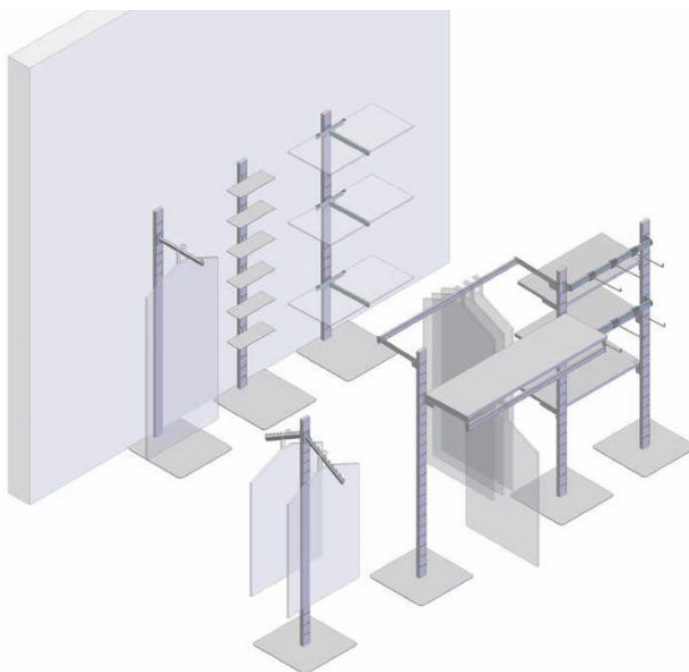

5. Góndola

Multiplas combinaciones para hacer góndolas  
Multiples combinaisons pour gondoles  
Multiple combinations for gondolas  
Combinazioni multiple per gondole

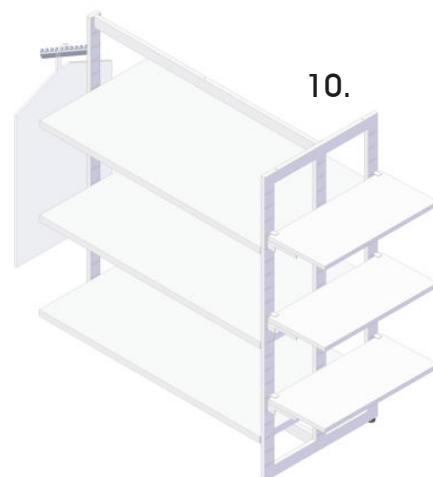
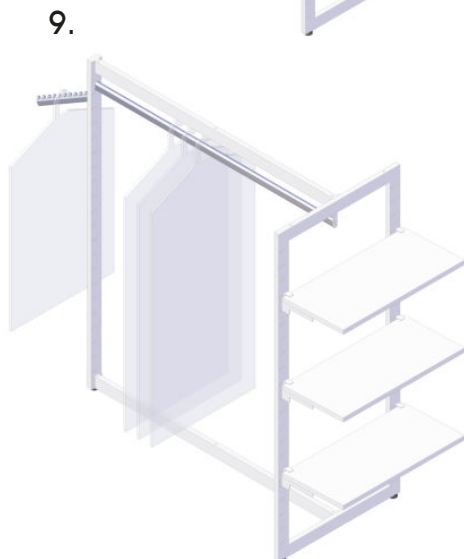
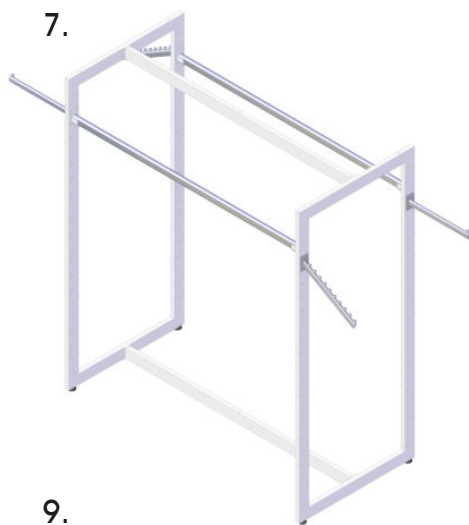
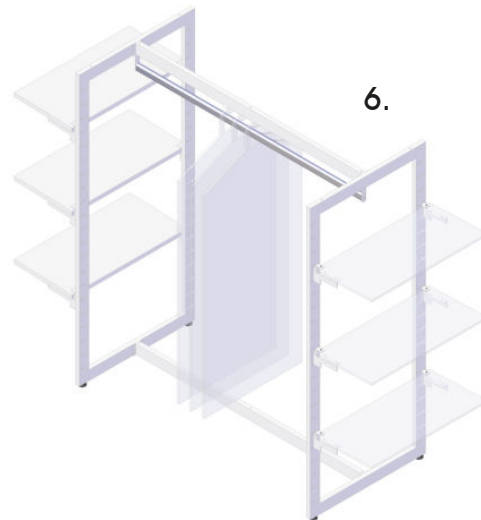

## COMPONENTES

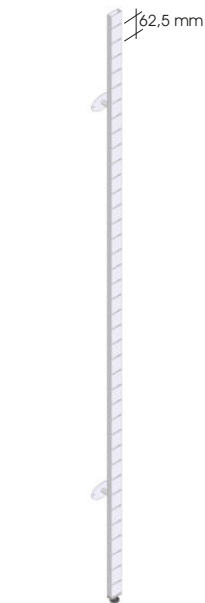

**GUÍA CREMALLERA**  
**CRÉMAILLÈRE**  
**UPRIGHT**  
**MONTANTE CREMALLERA**  
 Niveladores a pared y suelo  
 Niveleurs au mur et au sol  
 Levellers to wall and floor  
 Livellatori a muro e suolo  
**2640/0..**

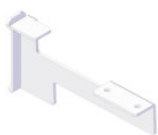

**CARTELA ESTANTE MADERA**  
**SUPPORT TABLETTE EN BOIX**  
**BRACKET FOR WOOD SHELF**  
**MENSOLA RIPIANO LEGNO**  
**2630/0.. der.**  
 droite/right/destra  
**2631/0.. izq.**  
 gauche/left/sinistra



**CARTELA ESTANTE VIDRIO**  
**SUPPORT TABLETTE VERRE**  
**BRACKET FOR GLASS SHELF**  
**MENSOLA RIPIANO VETRO**  
**2632/0.. der.**  
 droite/right/destra  
**2633/0.. izq.**  
 gauche/left/sinistra



**CARTELA PARA ESTANTE DE MADERA O VIDRIO Y BARRA CONFECCIÓN**  
**SUPPORT BARRE PENDERIE + TABLETTE VERRE ET BOIX**  
**BRACKET FOR HANGING BAR + GLASS OR WOOD SHELF**  
**MENSOLA BARRA APPENDERIA + RIPIANO VETRO O LEGNO**  
 min: 35 cm  
**2634/0.. der.**  
 droite/right/destra  
**2635/0.. izq.**  
 gauche/left/sinistra



**CARTELA BARRA ACCESORIOS**  
**SUPPORT BARRE ACCESSOIRES**  
**BRACKET FOR ACCESSORIES BAR**  
**MENSOLA BARRA ACCESSORI**  
**2638/0.. der.**  
 droite/right/destra  
**2639/0.. izq.**  
 gauche/left/sinistra



**TORNILLO-EMBELLECEDOR**  
**DISQUE DE FINITION**  
**STUD SCREW**  
**DISCO VITE**  
**4720/0..**

BLANCO BLANC WHITE BIANCO	NEGRO NOIR BLACK NERO	COLOR COULEUR COLOR COLORE	ZINCADO PL. ZINK ZINK PL. ZINCATO
OB	ON	OP	34

Fe	50x20x2425	€/u
----	------------	-----

--	--	--

Fe	19 mm	€/u
----	-------	-----

Fe	8-10 mm	€/u
----	---------	-----

Fe	∅4547	€/u
----	-------	-----

Fe	∅4547	€/u
----	-------	-----

Fe	∅4547	€/u
----	-------	-----



**TUBO CUELGA**  
**TUBE PENDERIE**  
**TUBE HANGING BAR**  
**TUBO PENDERIA**  
**4547/1..**



**PERROQUET PLANO**  
**PENDERIE FRONTALE**  
**STRAIGHT ARM**  
**APPENDERIA FRONTALE**  
**3019/0..**



**PERROQUET INCLINADO**  
**PERROQUET INCLINÉ**  
**SLOPING ARM**  
**APPENDERIA INCL.**  
 8 pins  
**3022/0..**



**GANCHO**  
**CROCHET**  
**HOOK**  
**BARETTA**  
**3014/0.. 25 cm**  
**3020/0.. 20 cm**  
**3021/0.. 10 cm**



**GANCHO PORTAPRECIO**  
**CROCHET PORTAPRIX**  
**HOOK LABEL-HOLDER**  
**BARETTA PORTAPREZZO**  
**3012/0.. 25 cm**



**PORTAPRECIO**  
**PORTAPRIX**  
**LABEL HOLDER**  
**PORTAPREZZO**  
**382/009**



**SISTEMA SEGURIDAD**  
**GANCHO SENCILLOS**  
**BLOCCAGE**  
**SECURITY LOCK**  
**BLOCCO SICUREZZA**  
**373/00N**



**SISTEMA SEGURIDAD**  
**GANCHOS DOBLES**  
**BLOCCAGE**  
**SECURITY LOCK**  
**BLOCCO SICUREZZA**  
**383/00N**



**IMÁN ESPECIAL PARA**  
**SISTEMA SEGURIDAD**  
**GANCHOS**  
**IMAN DESBLOCCAGE**  
**UNLOCK MAGNET**  
**MAGNETE SBLOCCO**  
**384/000**

CR. BRILLO CR. POLI BR. CHR. CR. LUC.	CR. MATE CHR. M M. CHR. CR. OPAC	BLANCO WHITE BIANCO	NEGRO BLACK NERO	COLOR COULEUR COLOR COLORE
32	31	OB	ON	OP

Fe	3 m	36x18x1,5	€/m
----	-----	-----------	-----

Fe	∅4547	∅20 30 cm	€/u
----	-------	-----------	-----

Fe	∅4547	∅16 30 cm	€/u
----	-------	-----------	-----

Fe	∅4547	∅6	€/u
----	-------	----	-----

Fe	∅4547	∅6 25 cm	€/u
----	-------	----------	-----

plas	∅3012	50x50	€/u
------	-------	-------	-----

plas	∅ max. ∅6	€/u
------	-----------	-----

plas	∅ max. ∅6	€/u
------	-----------	-----

plas	∅ max. ∅6	€/u
------	-----------	-----

GÓNDOLAS

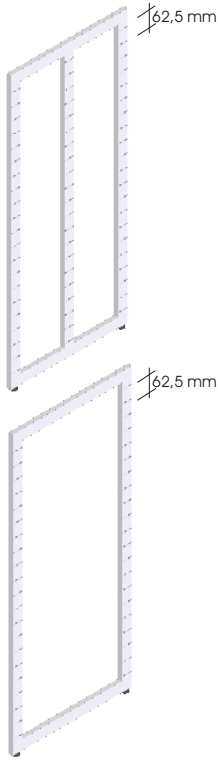

**MONTANTE CREMALL. 2 CARAS**  
**CRÉMAILLÈRE 2 CÔTES**  
**2 SIDES GONDOLA UPRIGHT**  
**MONTANTE CREMALLERA 2 LATI**  
Niveladores suelo  
Niveleurs au sol  
Floor levellers  
Livellatori suolo  
\*2641/0..

	BLANCO BLANC WHITE BIANCO	NEGRO NOIR BLACK NERO	COLOR COULEUR COLOR COLORE
	OB	ON	OP
Fe 1400x600x20 €/u			
	*o	*o	*o

**MONTANTE CREMALL. 2 CARAS**  
**CRÉMAILLÈRE 2 CÔTES**  
**2 SIDES GONDOLA UPRIGHT**  
**MONTANTE CREMALLERA 2 LATI**  
Niveladores suelo  
Niveleurs au sol  
Floor levellers  
Livellatori suolo  
\*2644/0..

	BLANCO BLANC WHITE BIANCO	NEGRO NOIR BLACK NERO	COLOR COULEUR COLOR COLORE
	OB	ON	OP
Fe 1400x600x20 €/u			
	*o	*o	*o

**MONTANTE CREMALL. 2 CARAS**  
**CRÉMAILLÈRE 2 CÔTES**  
**2 SIDES GONDOLA UPRIGHT**  
**MONTANTE CREMALLERA 2 LATI**  
Niveladores suelo  
Niveleurs au sol  
Floor levellers  
Livellatori suolo  
\*2642/0..

	BLANCO BLANC WHITE BIANCO	NEGRO NOIR BLACK NERO	COLOR COULEUR COLOR COLORE
	OB	ON	OP
Fe 1400x50x20 €/u			
	*o	*o	*o

**CREMALL. 2 CARAS + BASE**  
**CRÉMAILLÈRE 2 CÔTES + BASE**  
**2 SIDES UPRIGHT + BASE**  
**CREMALLERA 2 LATI + BASE**  
Base 380x380 mm  
Base 380x380 mm  
\*2648/0..

	BLANCO BLANC WHITE BIANCO	NEGRO NOIR BLACK NERO	COLOR COULEUR COLOR COLORE
	OB	ON	OP
Fe 1400x50x20 €/u			
	*o	*o	*o

**CREMALL. 1 CARA + BASE**  
**CRÉMAILLÈRE 1 CÔTES + BASE**  
**1 SIDE UPRIGHT + BASE**  
**CREMALLERA 1 LATO + BASE**  
Base 380x380 mm  
Base 380x380 mm  
\*2649/0..

	BLANCO BLANC WHITE BIANCO	NEGRO NOIR BLACK NERO	COLOR COULEUR COLOR COLORE
	OB	ON	OP
Fe 1400x50x20 €/u			
	*o	*o	*o

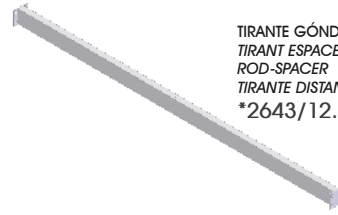

**TIRANTE GÓNDOLA**  
**TIRANT ESPACEMENT**  
**ROD-SPACER**  
**TIRANTE DISTANZIATORE**  
\*2643/12. 120 cm

	CR. BRILLO CH.R. POI BR. CH. CR. ILLC.	BLANCO BLANC WHITE BIANCO	NEGRO NOIR BLACK NERO	COLOR COULEUR COLOR COLORE
	32	OB	ON	OP
Fe 50x20 €/u				
	*o	*o	*o	

ACCESORIOS GÓNDOLAS

ACCESOIRES GONDOLA -  
GONDOLA ACCESSORIES -  
ACCESSORI GONDOLA



**SOPORTE CENTRAL**  
support central  
central support  
supporto centrale  
\*2645/0..

	Fe	∅4547	base 40 cm	€/u



**SOPORTE ESTANTE**  
**MADERA**  
**SUPPORT TABLETTE BOIX**  
**WOOD SHELF BRACKET**  
**SUPP. RIPIANO LEGNO**  
\*2646/0..

	Fe	base 20 mm	€/u



**SOPORTE PENDERIE**  
**A TIRANTE**  
**SUPPORT TUBE PENDERIE**  
**AU TIRANT ESPACEMENT**  
**TUBE SUPPORT**  
**TO ROD-SPACER**  
**SUPPORTO TUBO A**  
**TIRANTE DISTANZIATORE**  
\*2647/0..

	Fe	2643	∅4547	€/u

ACCESORIOS COMUNES MULTILAMAS

ACCESOIRES MULTILAMAS -  
MULTILAMAS ACCESSORIES -  
ACCESSORI MULTILAMAS

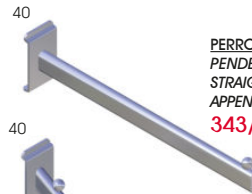

**PERROQUET PLANO**  
**PENDERIE FRONTALE**  
**STRAIGHT ARM**  
**APPENDERIA FRONTALE**  
\*343/0..

	Fe	base 40 mm	€/u

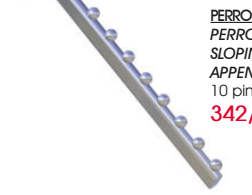

**PERROQUET INCLINADO**  
**PERROQUET INCLINÉ**  
**SLOPING ARM**  
**APPENDERIA INCL.**  
10 pins  
\*342/0..

	Fe	base 40 mm	€/u

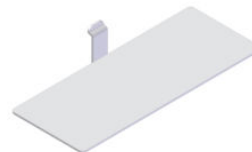

**SOPORTE CALZADO**  
**SOUTIEN CHAUSSANT**  
**FOOTWEAR SUPPORT**  
**SUPPORTO CALZATURE**  
\*315/0..

	Fe	250x100 mm	€/u



instal.

# OTROS SISTEMAS

## SISTEMAS SIN ILUMINACIÓN

### STAR 25

COMPONENTES  
TUBO OVALADO 36X18  
ACCESORIOS TUBO  
OVALADO 36X18

### STAR 8

SISTEMA ANTIGIRO

### CABLE DECO

### ÓPTICA

EXPOSITORES PARA GAFAS  
OPTI 3  
PARALELO 384

### JS-25

NUDOS  
TUBO 25MM  
ACCESORIOS  
CARTELAS

### STENDERS

### PROBADORES

### MALLAS

### GÓNDOLA EXPOSITOR

### BRIDAS

### BASIC - LOW COST

BASIC MAXI  
BASIC MINI

### CONCEPT -LOW COST

STAR 25

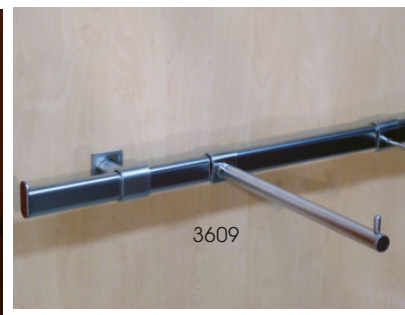
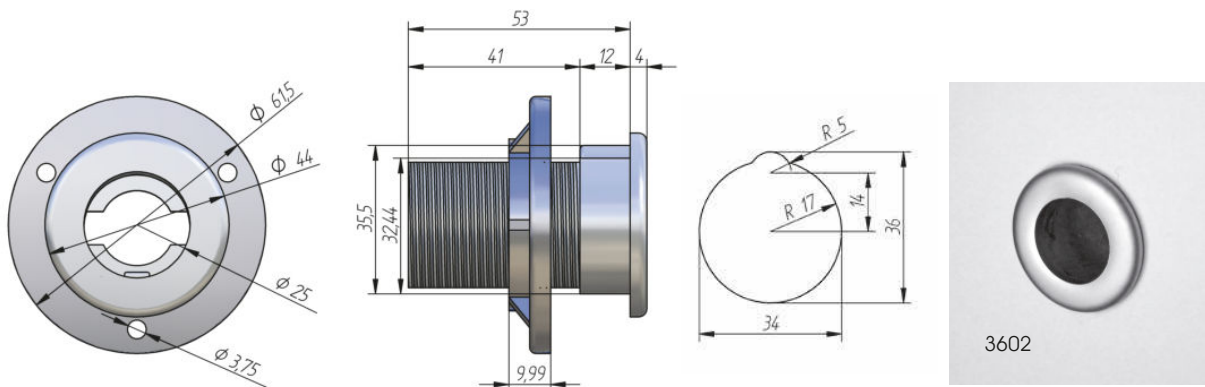

COMPONENTES



**CASQUILLO REDONDO Ø44**  
Accesorios Ø 25 mm  
INSERT ROND Ø44  
Acessorios Ø25mm  
ROUND SOCKET Ø44  
Fittings Ø25 mm  
BOCCOLA ROTONDA Ø44  
Accessori Ø25 mm  
**3602/0..**



**CARTELA SUPPORT BRACKET MENSOLA**  
**3620/0..**



**PERROQUET PLANO PENDIERE FRONTAL STRAIGHT ARM APPENDERIA FRONTALE**  
**3615/0..** 250 cm  
**3614/0..** 350 cm



**PERROQUET INCLINADO PENDIERE INCLINÉE SLOPING ARM APPENDERIA INCLINADA**  
**3617/0..**



**PERROQUET PLANO 'Z' PENDIERE FRONTAL 'Z' STRAIGHT ARM 'Z' APPENDERIA FRONTALE 'Z'**  
**3616/0..**



**CARTELA BARRA PENDIERE SUPPORT BARRE PENDIERE BRACKET HANGING BAR MENSOLA APPENDERIA**  
**3618/0..**



**CARTELA BARRA PENDIERE SUPPORT BARRE PENDIERE BRACKET HANGING BAR MENSOLA APPENDERIA**  
**3619/0..**



**CARTELA BARRA PENDIERE SUPPORT BARRE PENDIERE BRACKET HANGING BAR MENSOLA APPENDERIA**  
**3619/0..**

COLOR COULEUR COLOR COLORE	CR. BRILLO CHR. POLI BR. CHR CR. LUC.	CR. MATE CHR. M M. CHR CR. OPAC
OP	32	31

1x Ø 34 - 1x Ø 10
Zn 13-30 mm
12 kg/u €/u

Fe	Ø25
330 mm	€/u

Fe	Ø25
250 mm	€/u

Fe	Ø25
390 mm	€/u

Fe	Ø25
350 mm	€/u

Fe	Ø25
320 mm	€/u
∅4547(36x18)	€/u

Fe	Ø25
330 mm	€/u
∅4547(36x18)	€/u

Fe	Ø25
330 mm	€/u
∅4547(36x18)	€/u

Fe	Ø25
330 mm	€/u
∅4547(36x18)	€/u

Fe	Ø25
330 mm	€/u
∅4547(36x18)	€/u

Fe	Ø25
330 mm	€/u
∅4547(36x18)	€/u

Fe	Ø25
330 mm	€/u
∅4547(36x18)	€/u



**CARTELA BARRA ACCESORIOS SUPPORT BARRE ACCESSOIRES BRACKET FOR ACCESSORIES ROD MENSOLA TUBO PORTA-ACCESSORI**  
**3609/0..**

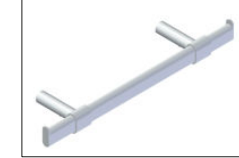

TUBO OVALADO 36X18



**TUBO OVAL 36x18 mm TUBE OVALE 36X18 mm OVAL TUBE 36X18 mm TUBO OVALE 36X18 mm**  
**4547/10P** PINTADO  
**4547/132**



**TAPA FINAL CON TOPE EMBOUT AVEC RETENTION END-CAP WITH STOP COPRITESTA + RETENZIONE**  
**4722/0..**

ACCESORIOS TUBO OVALADO 36X18



**PERROQUET PLANO PENDIERE FRONTAL STRAIGHT ARM APPENDERIA FRONTALE**  
**3019/0..**



**GANCHO CROCHET HOOK BARRETTA**  
**3014/0..** 25 cm



**GANCHO PORTAPRECIO CROCHET PORTAPRIX HOOK LABEL-HOLDER BARRETTA PORTAPREZZO**  
**3012/0..** 25 cm



**PORTAPRECIO PORTAPRIX LABELHOLDER PORTAPREZZO**  
**382/009**



**BLOQUEO GANCHO BLOCAGE BROCHE HOOK SECURITY LOCK BLOCCO SICUREZZA GANCIO**  
**373/00N**



**BLOQUEO GANCHO DOBLE BLOCAGE BROCHE DOUBLE DOUBLE HOOK SECURITY LOCK BLOCCO GANCIO DOPPIO**  
**383/00N**



**IMÁN ESPECIAL DESBLOQUEO UNLOCK MAGNET UNLOCK MAGNET MAGNETE DI SBLOCCO**  
**384/000**

COLOR COULEUR COLOR COLORE	CR. BRILLO CHR. POLI BR. CHR CR. LUC.	CR. MATE CHR. M M. CHR CR. OPAC
OP	32	31

Fe	Ø25
∅4547(36x18)	€/u
330 mm	€/u

Fe	Ø25
330 mm	€/u

Fe	Ø25
250 mm	€/u

Fe	Ø25
390 mm	€/u

Fe	Ø25
350 mm	€/u

Fe	∅4547
300 mm	€/u

Fe	∅4547
250 mm	€/u

Fe	∅4547
250 mm	€/u

PLÁSTICO PLASTIQUE PLASTIC PLASTICA	NEGRO NOIR BLACK NERO	BRUTO BRUT RAW GREZZO
09	0N	00

plas	40x50 mm	€/u
------	----------	-----

plas	Ø6 mm	€/u
------	-------	-----

plas	Ø6 mm	€/u
------	-------	-----

373-383/00N	€/u
-------------	-----

STAR 8

SISTEMA ANTIGIRO

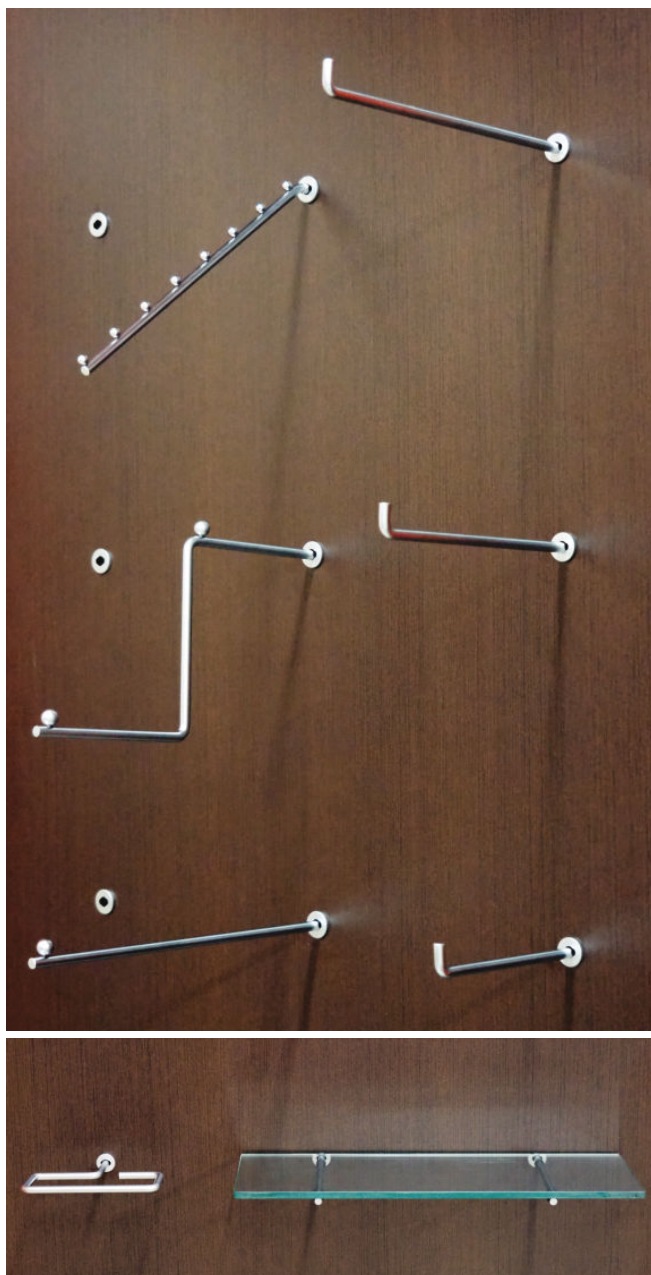

CR. MATE  
CHR. M  
M. CHR  
CR. OPAC  
**31**

CASQUILLO REDONDO Ø22

Accesorios Ø 8 mm  
INSERT ROND Ø22  
Accessoires Ø8mm  
ROUND SOCKET Ø22  
Fittings Ø8 mm  
BOCCOLA ROTONDA Ø22  
Accessori Ø8 mm



Zn	8-22 mm
1x Ø 8 - 1x Ø 4	
12 kg/u	€/u

**3604/N31**

○

GANCHO

HOOK  
BROCHE  
BARRETTA



Fe	Ø 8 mm	€/u
----	--------	-----

**3605/N31** 15 cm  
**3606/N31** 20 cm  
**3607/N31** 25 cm

○

○

○

CARTELA

SUPPORT  
BRACKET  
MENSOLA



Fe	Ø 8 mm	€/u
----	--------	-----

**3627/N31** 15 cm  
**3628/N31** 25 cm

○

○

PERROQUET

PERROQUET  
ARM  
APPENDERIA



Fe	Ø 8 mm	€/u
----	--------	-----

**3624/N31** 30 cm

○

PERROQUET INCLINADO

PERROQUET INCLINÉE  
SLOPING ARM  
APPENDERIA INCLINADA

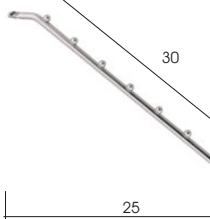

Fe	Ø 8 mm	€/u
----	--------	-----

**3625/N31**

○

PERROQUET "Z"

PERROQUET "Z"  
ARM "Z"  
APPENDERIA "Z"

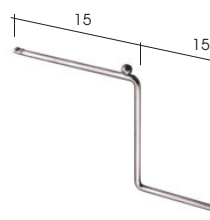

Fe	Ø 8 mm	€/u
----	--------	-----

**3629/N31**

○

SOPORTE ZAPATO

SUPPORT CHAUSSURE  
SHOE SHELF  
SUPPORTO SCARPA

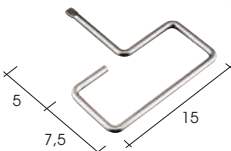

Fe	Ø 8 mm	€/u
----	--------	-----

**3623/N31**

○

SOPORTE ZAPATO

SUPPORT CHAUSSURE  
SHOE SHELF  
SUPPORTO SCARPA

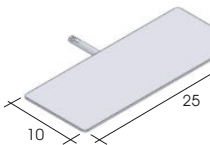

Fe	Ø 8 mm	€/u
----	--------	-----

**3630/N31**

○

SOPORTE OCULTO

ESTANTE DE MADERA  
SUPPORT DISSIMULÉ  
ÉTAGÈRE EN BOIS  
HIDDEN BRACKET  
WOODEN SHELF  
STAFFA NASCOSTA  
RIPIANI IN LEGNO



Fe	175 mm	€/u
----	--------	-----

**3631/034**

○

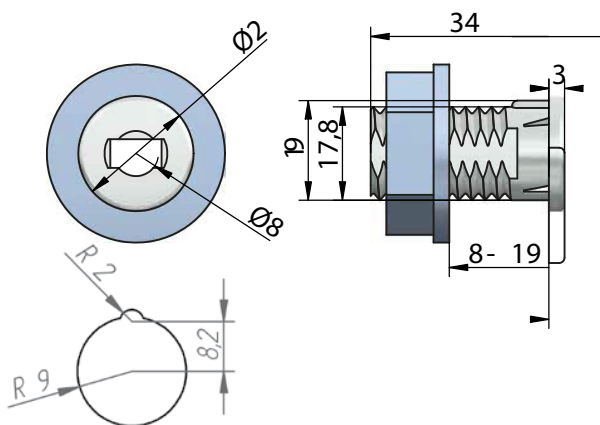

CABLE DECO



ENGANCHE TECHO  
ATELAGE PLAFOND  
CEILING CONNECTION  
AGGANCIO SOFFITTO  
**3410/032**

CR. BRILLO CHR. POLI BR. CHR CR. LUC.	32	
Cu	40kg/u	€/u



ROLLO  
50 METROS

CABLE INOX  
INOX WIRE  
Length: cut to size  
CÂBLE INOX  
Longueur: coupé à la taille  
CAVO INOX  
Lunghezza: tagliato a misura  
**3411/128** VENTA POR METRO  
**3411/028** VENTA ROLLO 50 M

INOX S.S.	40kg/u	Ø1,5mm	€/m	€/u
--------------	--------	--------	-----	-----



ENGANCHE SUELO CON TENSOR  
ATELAGE PAVEMENT  
FLOOR CONNECTION  
AGGANCIO PAVIMENTO CON TENSOR  
**3412/032**

Cu	€/u
----	-----



ENGANCHE REGULABLE SUELO 180°  
ATELAGE RÉGLABLE 180° PAVEMENT  
ADJUSTABLE 180° FLOOR CONNECTION  
AGGANCIO REGOLABILE 180° PAVIMENTO  
**3425/032**

Cu	€/u
----	-----



PINZA MÓVIL SENCILLA  
PINCE SIMPLES MOBILE  
SINGLE MOVABLE CLAMP  
MORSETTO MOBILE SEMPLICE  
**3415/032**

Cu	4-8 mm	€/u
----	--------	-----



PINZA MÓVIL DOBLE  
PINCE DOUBLE MOBILE  
DOUBLE MOVABLE CLAMP  
MORSETTO MOBILE DOPPIA  
**3416/032**

Cu	4-8 mm	€/u
----	--------	-----



SOPORTE ESTANTE VIDRIO  
CON TALADRO Ø14 MM  
GLASS SHELF SUPPORT WITH DRILL Ø14 mm  
SUPPORT DE TABLETTE AVEC TROU Ø14 mm  
SUPPORTO RIPIANO CON FORO Ø14 mm  
**3417/032**

Cu	Ø 14 mm	€/u
----	---------	-----



SOPORTE ESTANTE MADERA  
CON TALADRO  
SUPPORT DE TABLETTE AVEC TROU  
GLASS SHELF SUPPORT WITH DRILL  
SUPPORTO RIPIANO CON FORO  
**3418/032**

Cu	€/u
Ø	2 mm



PIEZA SEGURIDAD  
PIÈCE DE SÉCURITÉ  
SECURITY PIECE  
PEZZO DI SICUREZZA  
**3426/022**

INOX	€/u
------	-----



COLGADOR CUADROS  
HANGER PICTURES  
ANCRER POUR ACCROCHER TABLEAUX  
AGGANCIO PER APPENDERE QUADRI  
**3419/032**

CR. BRILLO CHR. POLI BR. CHR CR. LUC.	32
Cu	€/u

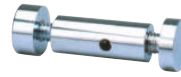

SOPORTE CUADRO CON TALADRO  
FRAME SUPPORT WITH DRILL  
SUPPORT TABLEAU AVEC TROU  
SUPPORTO PER QUADRO CON FORO  
**3420/032**

Cu	€/u
Ø	6 mm



ANCLAJE PESTAÑA ESTANTE INCLINADO  
SUPPORT ONGLET TABLETTE INCLINÉE  
TAB ANCHOR FOR INCLINED SHELF  
ANCORAGGIO BORDO RIPIANO INCLINATO  
\***3421/032**

Cu	€/u
Ø	6 mm



BARRA  
2 METROS

CARRIL PARA COLGAR A TECHO O  
A PARED.  
PROFIL POUR ACCROCHER AU PLAFOND  
OU AU MUR  
TRACK TO HANG ON THE CEILING  
OR WALL  
PROFILO DA APPENDERE A SOFFITTO  
O PARETE  
**3422/201**

Al	€/u
∞	3427-3423-3424



ENGANCHE CABLE A CARRIL 3422  
CÂBLE ATELAGE A LE PROFIL 3422  
WIRE/TRACK 3422 JOINT  
AGGANCIO CAVO AL PROFILO 3422  
\***3427/032**

Cu	€/u
∞	3422



ANCLAJE PARA COLGAR CUADROS  
A TECHO O PARED  
ANCRER POUR ACCROCHER TABLEAUX  
AU PLAFOND OU AU MUR  
HOOK FOR HANGING PICTURES  
ON THE WALL OR CEILING  
AGGANCIO PER APPENDERE QUADRI  
ALLA PARETE O AL SOFFITTO  
**3423/032**

Cu	€/u
∞	3422



ANCLAJE PARA COLGAR CUADROS  
A TECHO, PARED Y COLUMNAS KADÍ  
ANCRER POUR ACCROCHER TABLEAUX AU  
PLAFOND, AU MUR OU COLUMNS KADÍ  
HOOK FOR HANGING PICTURES ON THE  
WALL, CEILING OR KADÍ COLUMNS  
AGGANCIO PER APPENDERE QUADRI ALLA  
PARETE, AL SOFFITTO O COLONNE KADÍ  
**3424/032**

Cu	€/u
∞	3422

**3426**  
Pieza de seguridad.  
Evita que la balda se salga  
por la parte superior.

**3418**  
Pieza de anclaje.  
Se encastra a la madera  
para anclar en el punto  
deseado del cable.

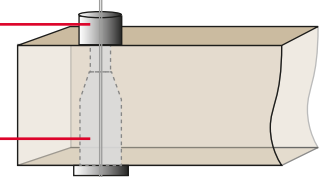

ÓPTICA

Con ó sin cerradura (misma llave)  
Ganchos de acero

PRÉSENTOIRS POUR LUNETTES  
Avec ou sans serrure (même combinaison)  
Crochets en acier inoxydable

DISPLAYS FOR GLASSES  
With or without lock (keyed alike)  
Wire in stainless steel

DISPLAYS PER OCCHIALI  
Con o senza serratura (stessa combinazione)  
Ganci in acciaio inox

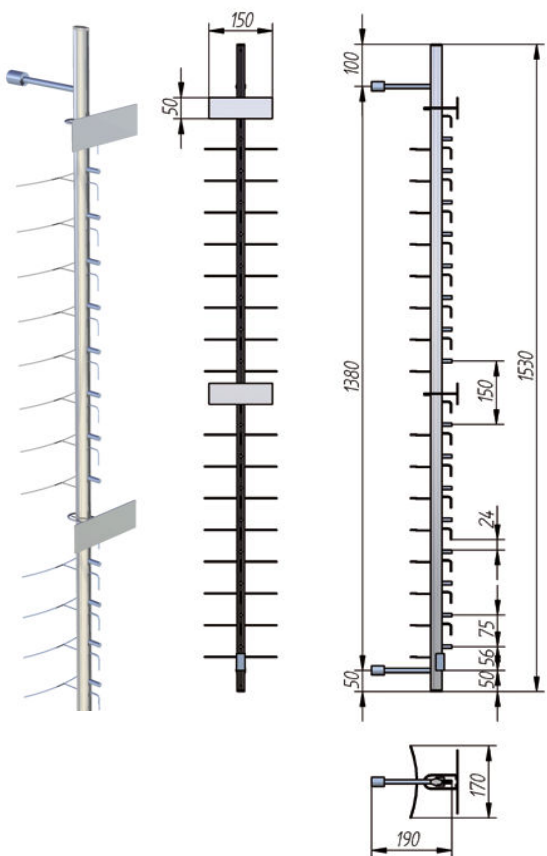

**BARRA PARED 8+8 CON CERRADURA**  
16 gafas - distancia gafas 75 mm  
**PRÉSENTOIR MURAL 8+8 AVEC SERRURE**  
16 lunettes - Distance lunettes: 75 mm  
**WALL DISPLAY 8+8 WITH LOCK**  
16 glasses - Distance glasses: 75 mm  
**DISPLAY PARETE 8+8 CON SERRATURA**  
16 occhiali - Distanza occhiali: 75 mm

2585/001

2 PORTARÓTULOS INCLUIDOS  
2 support-étiquettes inclus  
2 brand holders included  
2 supporti logo inclusi

PL. MATE ALU. MAT ALU. MATT ALL. NATURALE	
01	
Al	inox s.s.
153 cm	€/u

PORTARÓTULO NO INCLUIDOS  
support-étiquettes non inclus  
brand holder not included  
supporto logo non inclusi

EXPOSITORES PARA GAFAS

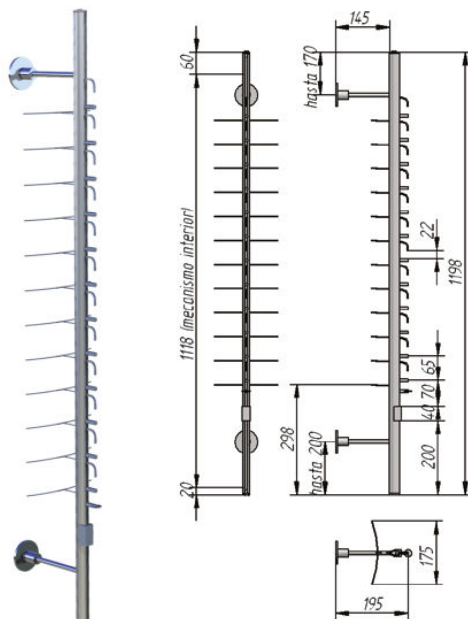

**BARRA PARED CON CERRADURA 120 cm**  
12 gafas - distancia gafas 70 mm  
**PRÉSENTOIR MURAL AVEC SERRURE 120 cm**  
12 lunettes - Distance lunettes: 65 mm  
**WALL DISPLAY WITH LOCK 120 cm**  
12 glasses - Distance glasses: 65 mm  
**DISPLAY PARETE CON SERRATURA 120 cm**  
12 occhiali - Distanza occhiali: 65 mm

2595/001

PL. MATE ALU. MAT ALU. MATT ALL. NATURALE	
01	
Al	inox s.s.
120 cm	€/u

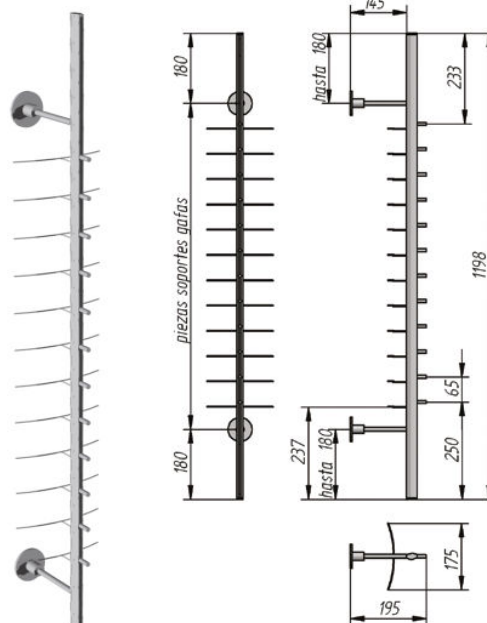

**BARRA PARED SIN CERRADURA 120 cm**  
12 gafas - distancia gafas 65 mm  
**PRÉSENTOIR MURAL SIN SERRURE 120 cm**  
12 lunettes - Distance lunettes: 65 mm  
**WALL DISPLAY WITHOUT LOCK 120 cm**  
12 glasses - Distance glasses: 65 mm  
**DISPLAY PARETE SENZA SERRATURA 120 cm**  
12 occhiali - Distanza occhiali: 65 mm

2591/001

PL. MATE ALU. MAT ALU. MATT ALL. NATURALE	
01	
Al	inox s.s.
120 cm	€/u

PORTARÓTULO NO INCLUIDOS  
support-étiquettes non inclus  
brand holder not included  
supporto logo non inclusi

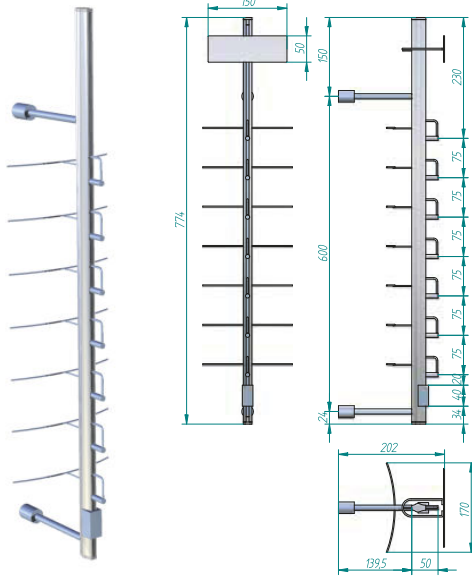

**BARRA PARED CON CERRADURA 77,4 cm**  
7 gafas - distancia gafas 75 mm

**PRÉSENTOIR MURAL AVEC SERRURE 77,4 cm**  
7 lunettes - Distance lunettes: 75 mm

**WALL DISPLAY WITH LOCK 77,4 cm**  
7 glasses - Distance glasses: 75 mm

**DISPLAY PARETE CON SERRATURA 77,4 cm**  
7 occhiali - Distanza occhiali: 75 mm

\*2597/001

**PORTARÓTULO NO INCLUIDOS**  
support-étiquettes non inclus  
brand holder not included  
supporto logo non inclusi



**PORTARÓTULO pintado en gris**  
SUPPORTÉTIQUETTE peint en gris  
BRAND HOLDER painted gray  
SUPPORTO LOGO verniciato grigio

2584/00M

PL. MATE  
ALU. MAT  
ALU. MATT  
ALL. NATURALE

01

Al	Inox	€/u
	S.S.	
		77,4 cm

\*o

Fe	150x50 mm	€/u
		∞ 2591-2594-2595-2597

o

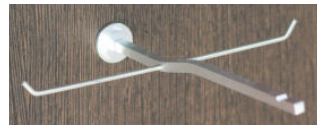

**SOPORTE GAFAS PANEL**

Se fija por detrás o delante  
**SUPPORT LUNETTES AU PANNEAU**  
Fixé de derrière le panneau  
**GLASSES SUPPORT TO PANEL**  
Fixed from behind the panel  
**SUPPORTO OCCHIALI A PANNELLO**  
Fissato da dietro

2593/001

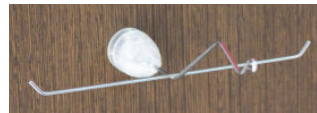

**SOPORTE GAFAS PANEL**

Se fija por delante  
**SUPPORT LUNETTES AU PANNEAU**  
Fixé devant le panneau  
**GLASSES SUPPORT TO PANEL**  
Fixed in front of the panel  
**SUPPORTO OCCHIALI A PANNELLO**  
Fissato da davanti

2592/032

PL. MATE  
ALU. MAT  
ALU. MATT  
ALL. NATURALE

01

Al	€/u
----	-----

172x170 mm

o

CR. BRILLO  
CH-R. POLI  
BR. CH-R  
CR. LUC.

32

Al	€/u
----	-----

180x190 mm

o

## OPTI-3



**PERFIL INVISIBLE PARA ESTANTES**  
DE 3 MM DE ESPESOR

PROFIL INVISIBLE POUR ÉTAGÈRES  
3 MM D'ÉPAISSEUR  
INVISIBLE PROFILE FOR SHELVES  
3 MM THICK  
PROFILO INVISIBLE PER RIPIANI DI  
3 MM DI SPESSORE

360/1..

Al	5 m	€/m
	6/8 mm	

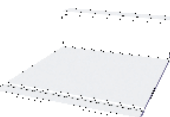

**SUPPORT-TABLETTE 3MM**  
FOLDED BRACKET-SHELF 3 MM  
MENSOLA-RIPIANO PIEDATA 3 MM

387/0.. 190MM

(POSIBILIDAD DE CORTE A MEDIDA BAJO PEDIDO)

Al	190x190x50 mm	€/u
----	---------------	-----



**ESTANTE 3 MM**  
SUPPORT-TABLETTE 3MM  
BRACKET-SHELF 3 MM  
MENSOLA-RIPIANO 3 MM

388/0..

Fe	€/u
----	-----

190x190 mm

## EXPOSITOR PARA FONDO DE METACRILATO

PRÉSENTOIR POUR FOND MÉTHACRYLATE  
DISPLAY FOR PLEXIGLASS BACK  
DISPLAY PER FONDO IN PLEXIGLASS

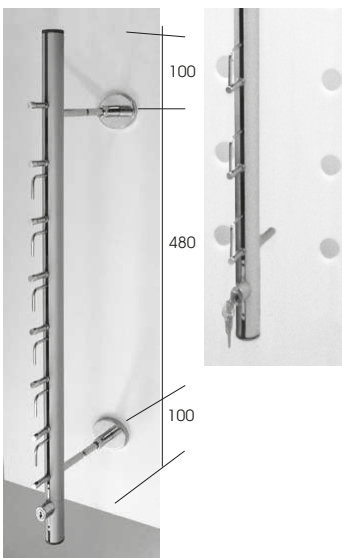

**EJEMPLO DE APLICACION CON PANEL**  
RETROILUMINADO Y AGUJEREO  
PARA APOYAR LAS GAFAS

EXEMPLE D'APPLICATION AVEC PANNEAU  
RÉTROÉCLAIRÉ ET TROUS  
POUR SOUTENIR LES LUNETTES  
APPLICATION EXAMPLE WITH BACKLIT  
PANEL WITH HOLES WITH HOLES AS  
GLASSES SUPPORT

ESEMPIO D'APPLICAZIONE CON PANNELLO  
RETROILLUMINATO E FORI  
COME SUPPORTO OCCHIALI

**EXPOSITOR SIN**  
REJILLA POSTERIOR  
6 gafas con cerr.+  
2 gafas sin cerr.  
distancia gafas 70 mm

**PRÉSENTOIR MURAL**  
SANS SUPPORT DARRIÈRE  
6 lunettes avec serrure et 2 sans -  
Distance lunettes: 70 mm

**WALL DISPLAY WOTHOUT BACK SUPPORT**  
6 glasses with lock and 2 without -  
Distance glasses: 70 mm

**DISPLAY PARETE SENZA SUPPORTO RETRO**  
6 occhiali con serratura e 2 senza -  
Distanza occhiali: 70 mm

\*2586/001

Al	Inox	€/u
	S.S.	
	68 cm	

\*o

## PARALELO 384

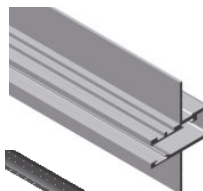

**PERFIL INVISIBLE**  
PROFIL D'ALUMINIUM  
ALUMINIUM PROFILE  
PROFILO DI ALLUMINIO

384/1..

Al	5 m	€/m
	∞ 384/1181	5/6/8 mm

**GOMA DURA**  
CAOUTCHOUC DUR  
HARD RUBBER  
GOMMA DURA

384/109

plas	∞ 384	€/m
------	-------	-----

o



**GANCHO GAFAS**  
SUPPORT POUR LUNETTES  
SUPPORT FOR GLASSES  
BARRETTA PER OCCHIALI

\*379/0..

Fe	€/u
----	-----

\*o

SISTEMA JS-25

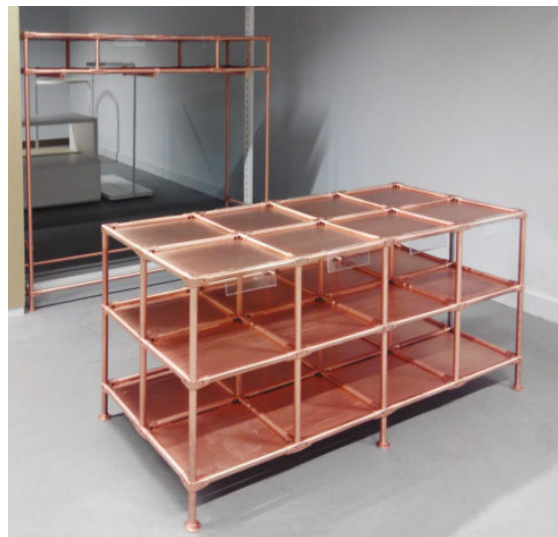

COMPONENTES

NUDOS



NUDO 3 SALIDAS  
JOINT À 3 VOIES  
3 WAY JOINT  
GIUNTO 3 VIE  
150/0..



NUDO 4 SALIDAS  
JOINT À 4 VOIES  
4 WAY JOINT  
GIUNTO 4 VIE  
151/0..



NUDO 4 SALIDAS  
JOINT À 4 VOIES  
4 WAY JOINT  
GIUNTO 4 VIE  
151/E..



NUDO 4 SALIDAS EN CRUZ  
JOINT À 4 VOIES À CROIX  
4 WAY CROSS-JOINT  
GIUNTO 4 VIE A CROCE  
152/0..



NUDO 5 SALIDAS  
JOINT À 5 VOIES  
5 WAY JOINT  
GIUNTO 5 VIE  
153/0..



NUDO 5 SALIDAS  
JOINT À 5 VOIES  
5 WAY JOINT  
GIUNTO 5 VIE  
153/L..



NUDO 5 SALIDAS  
JOINT À 5 VOIES  
5 WAY JOINT  
GIUNTO 5 VIE  
153/E..



NUDO PARALELO DOBLE  
JOINT À 2 VOIES PARALLÈLES  
2 PARALLEL WAY JOINT  
GIUNTO 2 VIE PARALLELE  
154/0..



NUDO PARALELO TRIPLE  
JOINT À 3 VOIES PARALLÈLES  
3 PARALLEL WAY JOINT  
GIUNTO 3 VIE PARALLELE  
\*155/0..



NUDO 6 SALIDAS  
JOINT À 2 VOIES  
2 WAY JOINT  
GIUNTO 2 VIE  
156/0..



NUDO 6 SALIDAS  
JOINT À 2 VOIES  
2 WAY JOINT  
GIUNTO 2 VIE  
156/E..



BRIDA ESPEJOS  
BRIDE MIROIRS  
CLAMP MIRRORS  
GIUNTO PER SPECCHIO  
\*159/0..

CR. BRILLO	CR. ORO	BLANCO	NEGRO	COLOR
CR. POLI	CR. DOR	BLANC	NOIR	COULEUR
BR. CHR.	GOLD. C	WHITE	BLACK	COLOR
CR. LUC.	CR. ORO	BANCO	NERO	COLORE
32	33	0B	0N	0P

RAL 9006 = color 0P  
metal. 0M= 032+50%

Al	Ø25	∞203	€/u
----	-----	------	-----

Al	Ø25	∞203	€/u
----	-----	------	-----

Al	Ø25	∞203	€/u
----	-----	------	-----

Al	Ø25	∞203	€/u
----	-----	------	-----

Al	Ø25	∞203	€/u
----	-----	------	-----

Al	Ø25	∞203	€/u
----	-----	------	-----

Al	Ø25	∞203	€/u
----	-----	------	-----

Al	Ø25	∞203	€/u
----	-----	------	-----

Al	Ø25	∞203	€/u
----	-----	------	-----

Al	Ø25	∞203	€/u
----	-----	------	-----

Al	Ø25	∞203	€/u
----	-----	------	-----

Al	Ø25	∞203	€/u
----	-----	------	-----

Al	Ø25	∞203	€/u
----	-----	------	-----

TUBO Ø25MM



TUBO Ø 25 mm  
TUBE Ø 25 mm  
TUBE Ø 25 mm  
TUBO Ø 25 mm

203/3.. 300 cm

Fe	3 m	€/u
----	-----	-----

ACCESORIOS



SOPORTE ABIERTO AJUSTABLE TUBO Ø25  
TUBE DE SUPPORT OUVERT RÉGLABLE Ø25  
ADJUSTABLE OPEN SUPPORT TUBE Ø25  
SUPPORTO APERTO REGOLABILE TUBO Ø25  
220/032

Al	Ø25	∞203	€/u
----	-----	------	-----



SOPORTE CERRADO AJUSTABLE TUBO Ø25  
TUBE DE SUPPORT FERMÉ RÉGLABLE Ø25  
ADJUSTABLE CLOSED SUPPORT TUBE Ø25  
SUPPORTO CHIUSO REGOLABILE TUBO Ø25  
221/032

Al	Ø25	∞203	€/u
----	-----	------	-----



ANILLO DE FIJACION A PARED  
ANNEAU DE FIXATION MURALE  
WALL FIXING RING  
GHIERA DI FISSAGGIO A PARETE  
225/0..

Al	Ø25	∞203	€/u
----	-----	------	-----



TAPÓN PARA TUBO  
BOUCHON POUR TUBE  
TUBE CAP  
TAPPO PER TUBO  
236/032

Al	Ø25	∞203	€/u
----	-----	------	-----



NIVELADOR TECHO  
VÉRIN SUPÉRIEURE (sol-plafond)  
UPPER LEVEL (floor-ceiling)  
LIVELLATORE SUPERIORE (suolo-soffitto)  
228/0..

Fe	Ø25	€/u
----	-----	-----



NIVELADOR SUELO  
VÉRIN INFÉRIEUR (sol-plafond)  
LOWER LEVEL (floor-ceiling)  
LIVELLATORE INFERIORE (suolo-soffitto)  
229/0..

Fe	Ø25	€/u
----	-----	-----



RUEDA + CASQUILLO Ø25  
ROUE + JOINT Ø25  
CASTOR + JOINT Ø25  
ROUTA + GIUNTO Ø25  
232/01N

plas	M8 Ø50	30kg/u	€/u
------	--------	--------	-----

CARTELAS



CARTELA FINAL  
SUPPORT FINAL  
FINAL BRACKET  
MENSOLA FINALE  
163/0..

Fe	300-350 mm Ø25	consultar medida	€/u
----	----------------	------------------	-----



CARTELA CENTRALE  
SUPPORT CENTRAL  
CENTRAL BRACKET  
MENSOLA CENTRALE  
165/0..

Fe	300-350 mm Ø25	consultar medida	€/u
----	----------------	------------------	-----

## STENDERS



**UNIVERSAL 1 m**  
altura regulable  
extensión lateral  
alto: 130/210 cm  
largo: 100/160 cm  
tubo de 28 mm  
rueda d.65 mm  
**PORTANT UNIVERSEL 100 cm**  
**UNIVERSAL FASHION RACK 100 cm**  
**STAENDER UNIVERSALE 100 cm**  
**26/032**

CR. BRILLO	CHR. POLI	BR. CHROME	CR. LUCIDO
32			
Fe	↔100/160 cm		
⌀	130/210 cm	€/u	



**UNIVERSAL 1.4 m**  
altura regulable  
extensión lateral  
alto: 130/210  
largo: 140/200  
tubo de 28 mm  
rueda D.50 mm  
**PORTANT UNIVERSEL 140 cm**  
**UNIVERSAL FASHION RACK 140 cm**  
**STAENDER UNIVERSALE 140 cm**  
**28/032**

Fe	↔140/200 cm		
⌀	130/210 cm	€/u	



**UNIVERSAL DOBLE 1.4 m**  
altura regulable  
extensión lateral  
alto: 130/210  
largo: 140/200  
tubo de 28 mm  
**PORTANT DOUBLER UNIVERSEL 140 cm**  
**UNIVERSAL FASHION DOUBLE RACK 140 cm**  
**STAENDER DOPPIO UNIVERSALE 140 cm**  
**29/032**

Fe	↔140/200 cm		
⌀	130/210 cm	€/u	



25 Ø



**\*BANDEJA:  
VENTA POR  
SEPARADO**



## PROBADORES

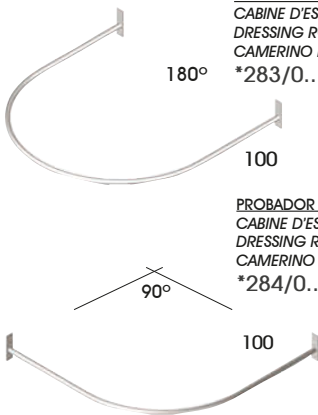

**PROBADOR ISLA**  
**CABINE D'ESSAYAGE**  
**DRESSING ROOM**  
**CAMERINO PROVA**  
**\*283/0..**

**PROBADOR RINCÓN**  
**CABINE D'ESSAYAGE**  
**DRESSING ROOM**  
**CAMERINO PROVA**  
**\*284/0..**

CR. BRILLO	BLANCO	NEGRO	COLOR
CHR. POLI	BLANC	NOIR	COULEUR
BR. CHR.	WHITE	BLACK	COLOR
CR. LUC.	BIANCO	NERO	COLORE
32	OB	ON	OP

Fe	€/u
100x100 cm	

Fe	€/u
100x100 cm	



**STENDER PEQUEÑO**  
**STENDER PETIT**  
**STENDER SMALL**  
**STAENDER PICCOLO**  
**31/0..**

Fe	40 kg	↔70 cm
⌀150 cm €/u		



**STENDER MEDIANO**  
**STENDER MOYEN**  
**STENDER MEDIUM**  
**STAENDER MEDIUM**  
**32/0..**

Fe	40 kg	↔100 cm
⌀150 cm €/u		



**STENDER GRANDE**  
**STENDER GRAND**  
**STENDER LARGE**  
**STAENDER GRANDE**  
**33/0..**

Fe	40 kg	↔140 cm
⌀150 cm €/u		



**BANDEJA**  
**STENDER GRAND**  
**STENDER LARGE**  
**STAENDER GRANDE**  
**38/0..**

Fe	15 kg
30x38x2,5 cm €/u	

MALLAS

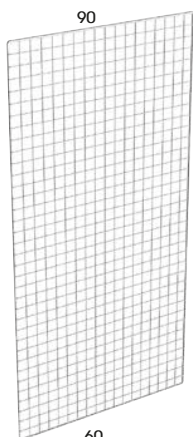

MALLA 180 X 90 cm  
GRILL PANEL 1800x900 mm  
PANNEAU À GRILLE 1800x900 mm  
PANNELLO GRIGLIATO 1800x900 mm  
\*175/0..

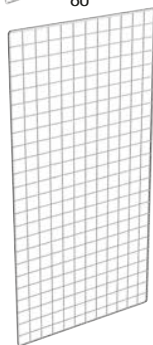

MALLA 120 X 60 cm  
GRILL PANEL 1200x600 mm  
PANNEAU À GRILLE 1200x600 mm  
PANNELLO GRIGLIATO 1200x600 mm  
\*178/0..

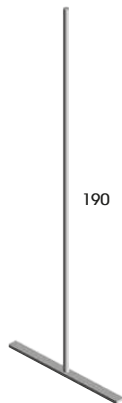

GÓNDOLA-EXPOSITOR

PIE GÓNDOLA CON RUEDA 232  
GONDOLA SELF-SUPPORTING UPRIGHT  
Castor Ø50 mm included  
GONDOLA MONTANT AUTO-PORTANT  
Roue Ø50 mm inclus  
MONTANTE GONDOLA  
Ruota Ø50 mm inclusa  
\*322/0..

PIE GÓNDOLA CON NIVELADOR 231  
GONDOLA SELF-SUPPORTING UPRIGHT  
Levellers included  
GONDOLA MONTANT AUTO-PORTANT  
Vérin inclus  
MONTANTE GONDOLA  
Piedino livellatore incluso  
\*324/0..

BRIDAS



SOPORTE MALLA PARED  
WALL SUPPORT FOR GRILL PANEL  
SUPPORT A MUR POUR PANNEAU  
À GRILLE  
SUPPORTO A PARETE PER PANNELLO  
GRIGLIATO  
\*185/X..



BRIDA Ø10/Ø10 mm  
CLAMP Ø10/Ø10 mm  
ETAU Ø10/Ø10 mm  
MORSETTO Ø10/Ø10 mm  
\*187/X..



BRIDA Ø25/Ø10 mm  
CLAMP Ø25/Ø10 mm  
ETAU Ø25/Ø10 mm  
MORSETTO Ø25/Ø10 mm  
\*186/0..

CR. BRILLO	BLANCO	NEGRO	COLOR
CR. POLI	BLANC	NOIR	COULEUR
BR. CHR	WHITE	BLACK	COLOR
CR. LUC.	BIANCO	NERO	COLORE

32	OB	ON	OP
RAL 9006 = color OP			
metal. 0M= 032+50%			
Fe	180x90 cm	50x50	€/u

Fe	120x60 cm	50x50	€/u
----	-----------	-------	-----

ACCESORIOS



GANCHO  
CROCHET  
HOOK  
BARRETTA  
\*335/X32 10 cm

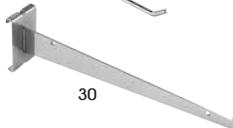

CARTELA ESTANTE MADERA  
SUPPORT TABLET BOIS  
WOOD SHELF BRACKET  
MENSOLA RIPIANO LEGNO  
\*318/X..

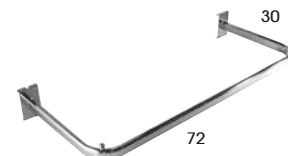

BARRA PENDERIE  
BARRE PENDERIE  
HANGING BAR  
BARRA APPENDERIA  
\*325/0..

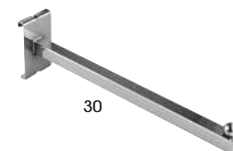

PERROQUET PLANO  
PENDERIE FRONTAL  
STRAIGHT ARM  
APPENDERIA FRONTALE  
\*339/0..



CESTA REJILLA  
GRID BASKET  
PANIER DE GRILLE  
CESTINO GRIGLIA  
\*345/0..

CR. BRILLO	BLANCO	NEGRO	COLOR
CR. POLI	BLANC	NOIR	COULEUR
BR. CHR	WHITE	BLACK	COLOR
CR. LUC.	BIANCO	NERO	COLORE

32	OB	ON	OP
Fe			
€/u			

Fe	300 mm	€/u
----	--------	-----

Fe	72x35 cm	€/u
12 kg/u		

Fe	300 mm	€/u
----	--------	-----

Fe	600x310 mm	€/u
----	------------	-----

**BASIC** LOW COST



**BASIC MAXI**

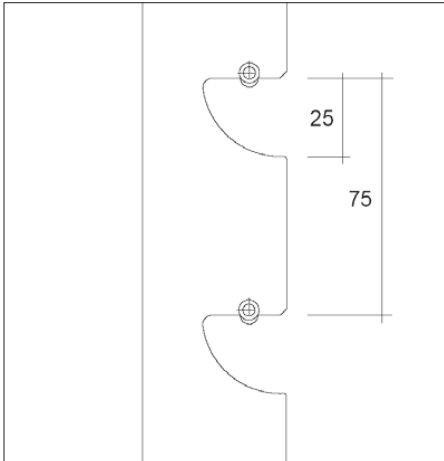

**BASIC MINI**

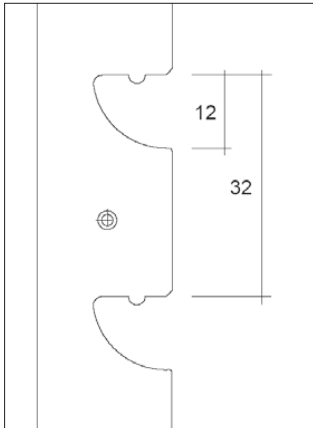
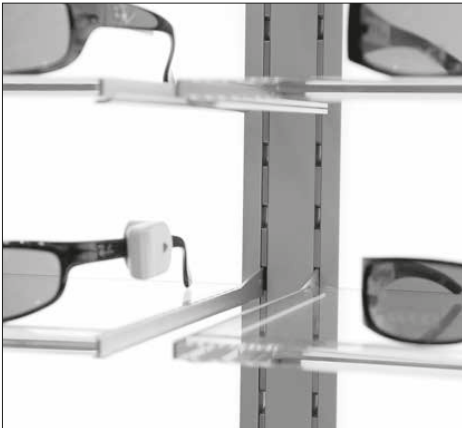

BASIC MAXI

INOX SAT  
INOX SAT  
S.S.S.  
INOX SAT  
28

INOX SAT  
INOX SAT  
S.S.S.  
INOX SAT  
28

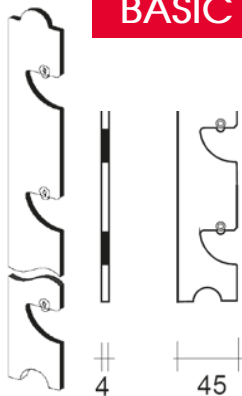

**GUÍA CREMALLERA 1 CANAL**  
CRÉMAILLÈRE  
RACK  
CREMAGUERA  
\*2500/028 derecha  
droite/right/destra  
\*2501/028 izquierda  
gauche/left/sinistra

inox s.s. 1200 mm  
45x4 €/u

\*O

\*O

25  
25

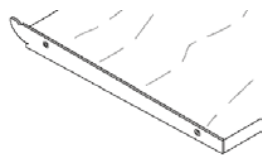

**CARTELA ESTANTE MADERA**  
SUPPORT TABLETTES BOIS  
WOOD SHELF BRACKET  
MENSOLA RIPIANO LEGNO  
\*2508/028 derecha  
droite/right/destra  
\*2509/028 izquierda  
gauche/left/sinistra

inox s.s. 25 mm  
305 mm €/u

\*O

\*O

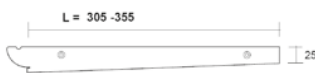

**CARTELA ESTANTE MADERA**  
SUPPORT TABLETTES BOIS  
WOOD SHELF BRACKET  
MENSOLA RIPIANO LEGNO  
\*2510/028 derecha  
droite/right/destra  
\*2511/028 izquierda  
gauche/left/sinistra

inox s.s. 25 mm  
355 mm €/u

\*O

\*O



**CARTELA SUPPORT BRACKET MENSOLA**  
\*2514/028 derecha  
droite/right/destra  
\*2515/028 izquierda  
gauche/left/sinistra

inox s.s. 355 mm €/u  
∅ 2551-2550

\*O

\*O



**CARTELA INTERMEDIA SUPPORT INTERMEDIAIRE INTERMEDIATE BRACKET MENSOLA INTERMEDIA**  
\*2516/028

inox s.s. 305 mm €/u  
∅ 2551-2550

\*O

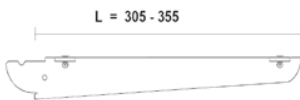

**CARTELA INTERMEDIA SUPPORT INTERMEDIAIRE INTERMEDIATE BRACKET MENSOLA INTERMEDIA**  
\*2518/028

inox s.s. 355 mm €/u  
2514-2515 ∅ 2551-2550 (x2)

\*O



**CARTELA INCLINADA 30° SUPPORT INCLINÉE 30° SLOPPING BRACKET 30° MENSOLA INCLINATA 30°**  
\*2520/028 derecha  
droite/right/destra  
\*2521/028 izquierda  
gauche/left/sinistra

inox s.s. 25 mm  
355 mm €/u

\*O

\*O

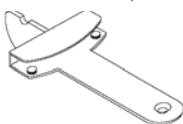

**CARTELA ESTANTE VIDRO SUPPORT TABLETTES VERRE GLASS SHELF BRACKET MENSOLA RIPIANO VETRO**  
\*2527/028

inox s.s. 8 mm  
105 mm €/u

\*O

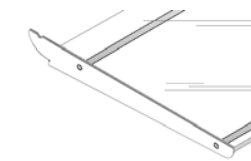
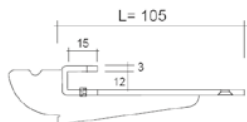

**CARTELA ESTANTE VIDRO SUPPORT TABLETTES VERRE GLASS SHELF BRACKET MENSOLA RIPIANO VETRO**  
\*2524/028 derecha  
droite/right/destra  
\*2525/028 izquierda  
gauche/left/sinistra

inox s.s. 8 mm  
355 mm €/u  
∅ 2551-2550 (x2)

\*O

\*O



**CARTELA INTERMEDIA SUPPORT INTERMEDIAIRE INTERMEDIATE BRACKET MENSOLA INTERMEDIA**  
\*2526/028

inox s.s. 8 mm  
355 mm €/u  
2524-2525 ∅ 2551-2550 (x2)

\*O

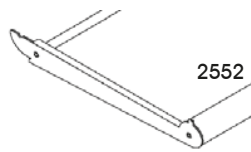

**CARTELA BARRA PENDERIE SUPPORT BARRE PENDERIE BRACKET HANGING BAR MENSOLA APPENDERIA**  
\*2528/028 derecha  
droite/right/destra  
\*2529/028 izquierda  
gauche/left/sinistra

inox s.s. 300 mm €/u  
∅ 2551-2550, 2552-2553

\*O

\*O

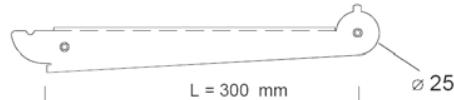

2528-2529 ∅ 2551-2550, 2552-2553

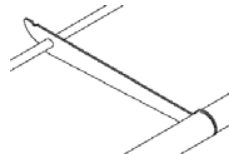

**CARTELA INTERMEDIA SUPPORT INTERMEDIAIRE INTERMEDIATE BRACKET MENSOLA INTERMEDIA**  
\*2530/028

inox s.s. 305 mm €/u

\*O

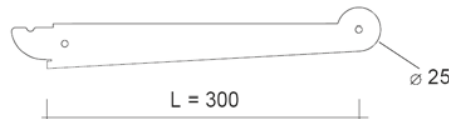

**CARTELA + BARRA PENDERIE SUPPORT + BARRE PENDERIE BRACKET + HANGING BAR MENSOLA + APPENDERIA**  
\*2532/028 derecha  
droite/right/destra  
\*2533/028 izquierda  
gauche/left/sinistra

inox s.s. 300 mm €/u  
∅ 2551-2550, 2552-2553

\*O

\*O

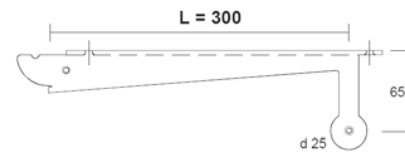
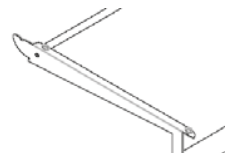

**VENTOSA VENTOUSE SUCTION VENTOSA**  
2556/009

plas Ø14 €/u

O

		INOX SAT	INOX SAT	INOX SAT
		S.S.S.	S.S.S.	INOX SAT
		28		
2532-2533 ∞ 2551-2550, 2552-2553		inox s.s.	300 mm	€/u
<b>CARTELA INTERMEDIA</b> SUPPORT INTERMEDIAIRE INTERMEDIATE BRACKET MENSOLA INTERMEDIA *2534/028		*O		
<b>BARRA TELESCÓPICA PENDERIE</b> BARRE TELESCOPIQUE PENDERIE TELESCOPIC HANGING BAR BARRA TELESCOPICA APPENDERIA *2536/028		inox s.s.	380+200 mm	€/u
		*O		
<b>BARRA TELESCÓPICA PENDERIE</b> BARRE TELESCOPIQUE PENDERIE TELESCOPIC HANGING BAR BARRA TELESCOPICA APPENDERIA *2537/028		inox s.s.	380 + 200 mm	€/u
		*O		
<b>PERROQUET PLANO</b> PENDERIE FRONTAL STRAIGHT ARM APPENDERIA FRONTALE *2538/028		inox s.s.	300 mm	€/u
		*O		
<b>PERROQUET INCLINADO 30°</b> PERROQUET INCLINÉE 30° SLOPING ARM 30° APPENDERIA INCLINADA 30° *2539/028		inox s.s.	300 mm	€/u
		*O		
<b>PERROQUET PLANO "Z"</b> PENDERIE FRONTAL "Z" STRAIGHT ARM "Z" APPENDERIA FRONTALE "Z" *2540/028		inox s.s.	300 mm	€/u
		*O		
<b>GANCHO</b> CROCHET HOOK BARRETTA *2541/028		inox s.s.	200 mm	€/u
		*O		

		INOX SAT	INOX SAT	INOX SAT
		S.S.S.	S.S.S.	INOX SAT
		28		
inox s.s.		300 mm	€/u	
∞ 2554 (30x15)				
<b>PERROQUET INCLINADO</b> PERROQUET INCLINÉE SLOPING ARM APPENDERIA INCLINADA *2543/028		*O		
inox s.s.		25 mm	€/u	
∞ 2554 (30x15)				
<b>CARTELA BARRA ACCESORIOS</b> SUPPORT BARRE ACCESSOIRES BRACKET FOR ACCESSORIES ROD MENSOLA TUBO PORTA-ACCESSORI *2546/028 derecha droite/right/destra *2547/028 izquierda gauche/left/sinistra		*O		
inox s.s.		50 mm	€/u	
<b>PORTARÓTULO</b> SUPPORTÉTIQUETTE BRAND HOLDER SUPPORTO LOGO *2548/028 derecha droite/right/destra *2549/028 izquierda gauche/left/sinistra		*O		
inox s.s.		3 m	∅10	€/m
TUBO ∅10				
TUBE ∅10				
TUBO ∅10				
*2550/128		*O		
<b>CONEXION ENTRE TUBO 2550 Y CARTELA</b> JOINT ENTRE LE TUBE 2550 ET LE SUPPORT JOINT BETWEEN TUBE 2550 AND BRACKET GIUNTO FRA TUBO 2550 E MENSOLA *2551/001		*O		
inox s.s.		6 m	∅25	€/m
TUBO ∅25				
TUBE ∅10				
TUBO ∅10				
*2550/128		*O		
<b>CONEXION ENTRE TUBO 2552 Y CARTELA</b> JOINT ENTRE LE TUBE 2552 ET LE SUPPORT JOINT BETWEEN TUBE 2552 AND BRACKET GIUNTO FRA TUBO 2552 E MENSOLA *2553/001		*O		
inox s.s.		3 m	30x15	€/m
TUBO 30X15				
TUBE 30X15				
TUBO 30X25				
*2554/128		*O		

BASIC MINI

INOX SAT  
INOX SAT  
S.S.S.  
INOX SAT  
28

INOX SAT  
INOX SAT  
S.S.S.  
INOX SAT  
28

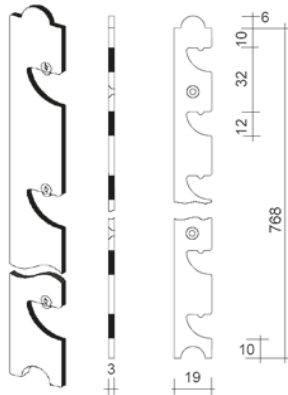

GUÍA CREMALLERA 1 CANAL  
CRÉMALLÈRE  
RACK  
CREMAGLIERA  
\*2560/028 derecha  
droite/right/destra  
\*2561/028 izquierda  
gauche/left/sinistra

inox s.s. ↑ 768 mm 19x3 €/u

\*  
\*

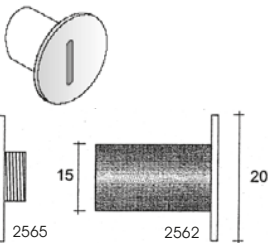

CASQUILLO REDONDO Ø20  
Accesorios MINI  
INSERT ROND Ø20  
Accessoires MINI  
ROUND SOCKET Ø20  
Fittings MINI  
BOCCOLA ROTONDA Ø20  
Accessori MINI  
\*2562/028

Zn ∅ 15 mm ∅ 20 €/u

\*  
\*

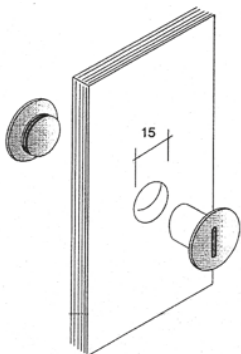

FIJACIÓN POSTERIOR CASQUILLO 2562  
FIXATION DERRIÈRE INSERT 2562  
BEHIND FIXING SOCKET 2562  
FISSAGGIO POSTERIORE BOCCOLA 2562  
\*2565/028

inox s.s. ∅ 20 €/u

\*  
\*

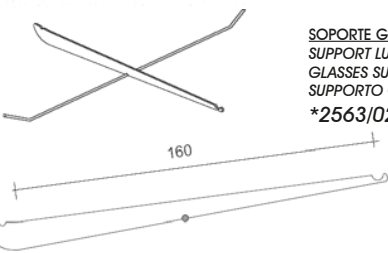

SOPORTE GAFAS  
SUPPORT LUNETTES  
GLASSES SUPPORT  
SUPPORTO OCCHIALI  
\*2563/028

inox s.s. 160x180 mm €/u

\*  
\*

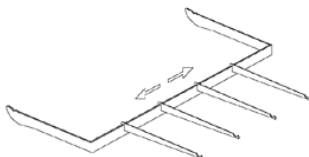

SOPORTE 4 GAFAS  
SUPPORT 4 LUNETTES  
4 GLASSES SUPPORT  
SUPPORTO 4 OCCHIALI  
\*2564/028

inox s.s. 778 mm €/u

\*  
\*

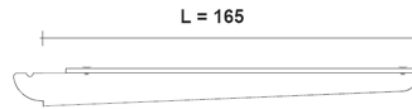

CARTELA ESTANTE VIDRO  
SUPPORT TABLETTES VERRE  
GLASS SHELF BRACKET  
MENSOLA RIPIANO VETRO  
\*2566/028 derecha  
droite/right/destra  
\*2567/028 izquierda  
gauche/left/sinistra

inox s.s. 165 mm €/u  
∅ 2571-2570+2556

\*  
\*



VIDRIO NO INCLUIDO  
VERRE NON INCLUS  
GLASS NOT INCLUDED  
VETRO NON INLUSO

CARTELA ESTANTE VIDRO  
SUPPORT TABLETTES VERRE  
GLASS SHELF BRACKET  
MENSOLA RIPIANO VETRO  
\*2568/028

inox s.s. €/u

\*  
\*



PORTARÓTULO  
SUPPORTÉTIQUETTE  
BRAND HOLDER  
SUPPORTO LOGO

\*2572/028 derecha  
droite/right/destra  
\*2573/028 izquierda  
gauche/left/sinistra

inox s.s. 60 mm €/u

\*  
\*

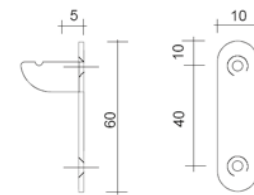

TUBO Ø8  
TUBE Ø8  
TUBE Ø8  
TUBOØ8

\*2570/128

inox s.s. L 3 m ∅8 €/m

\*  
\*



CONEXIÓN ENTRE TUBO 2570 Y CARTELA  
JOINT ENTRE LE TUBE 2570 ET LE SUPPORT  
JOINT BETWEEN TUBE 2570 AND BRACKET  
GIUNTO FRA TUBO 2570 E MENSOLA  
\*2571/001

\*  
\*



VENTOSA  
VENTOUSE  
SUCTION  
VENTOSA

2556/009

plas ∅14 €/u

\*  
\*

CONCEPT

LOW COST





PL. MATE  
ALU. MAT  
ALU. MATT  
ALL. NAT  
**01**

Al	‡ 210/350cm	Ø40	€/u
----	-------------	-----	-----

**MONTANTE TELESCOPICO COMPLETO**  
MÂT TÉLESCOPIQUE COMPLET  
COMPLET TELESCOPIC ROD  
PIANTANA TELESCOPICA COMPLETA  
**\*2700/301**

\*o



**BASE DE ALUMINIO**  
BASE EN ALUMINIUM  
ALUMINIUM BASE  
BASE DI ALLUMINIO  
**\*2702/001**

Al	Ø40	€/u
----	-----	-----

\*o



**EMPALMADOR TUBO Ø40**  
JOINT COLONNES TUBE Ø40  
COLUMNS JOINT TUBE Ø40  
GIUNZIONE PIANTANE TUBO Ø40  
**\*2707/001**

plas	Ø40	€/u
------	-----	-----

\*o



**NUDO DE ALUMINIO**  
JOINT EN ALUMINIUM  
ALUMINIUM JOINT  
GIUNTO DI ALLUMINIO  
**\*2711/001**

PL. MATE  
ALU. MAT  
ALU. MATT  
ALL. NAT  
**01**

Al	Ø40	€/u
----	-----	-----

\*o



**CARTELA CENTRAL**  
SUPPORT CENTRAL  
CENTRAL BRACKET  
MENSOLA ICENTRALE  
**\*2758/00M** derecha  
droite/right/destra  
**\*2759/00M** izquierda  
gauche/left/sinistra

Fe	275 mm	€/u
	RAL9006	€/u

\*o

\*o



**VENTOSA**  
VENTOUSE  
SUCTION  
VENTOSA  
**319/009**

plas	Ø20	€/u
------	-----	-----

o



**VENTOSA**  
VENTOUSE  
SUCTION  
VENTOSA  
**2556/009**

plas	Ø14	€/u
------	-----	-----

o



**ESTANTE REDONDO+ANCLAJES**  
TABLETTE CIRCULAIRE+ FIXATIONES  
ROUND SHELF +JOINTS  
RIPIANO CIRCOLARE+FISSAGGI  
**\*2718/001**

Al	4 mm	€/u
	Ø500	€/u

\*o

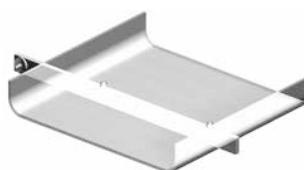

**CARTELA LATERAL + ESTANTE**  
SUPPORT LATERAL + TABLETTE  
BRACKET + SHELF  
MENSOLA + RIPIANO  
**\*2719/001**

Al	420x390	€/u
	5 mm	€/u

\*o

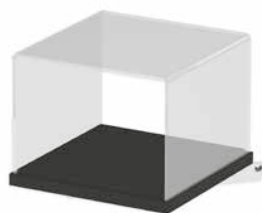

**VITRINA CON CERRADURA**  
VETRINE AVEC SERRURE  
SHOWCASE WITH LOCK  
VETRINA CON SERRATURA  
**\*2760/001**

MD plas	€/u
	30,5x30,5x20 cm

\*o

NEGRO  
NOIR  
BLACK  
NERO



**SOPORTE LATERAL PARA MUEBLES**  
SUPPORT LATERAL POUR MOBLES  
LATERAL SUPPORT FOR FURNITURE  
SUPPORTO LATERALE PER MOBILI  
**\*2736/001**

Al	30 mm M8	€/u
	Ø10	€/u

\*o

## CONCEPT

LOW COST

PL. MATE  
ALU. MAT  
ALU. MATT  
ALL. NAT  
**01**

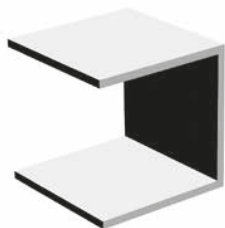

**MÓDULO LATERAL MADERA**  
*Module latéral bois*  
*Wood lateral module*  
*modulo laterale legno*  
**\*2737/00B**

BLANCO  
BLANC  
WHITE  
BIANCO

MD 39,5x39,5x39 cm  
∞ 2736 (x2) €/u

\*O

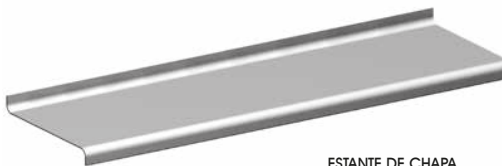

**ESTANTE DE CHAPA**  
*TABLETTE TÔLE*  
*METAL SHEET SHELF*  
*RIPIANO METALLICO*  
**\*2726/00M 119x42 cm**  
**\*2729/00M 93x42 cm**

PL. MATE  
ALU. MAT  
ALU. MATT  
ALL. NAT  
**01**

Fe 2 mm  
RAL9006 €/u

\*O  
\*O



**MÓDULO CENTRAL MADERA**  
*Module central bois*  
*Wood central module*  
*modulo centrale legno*  
**\*2739/00B**

BLANCO  
BLANC  
WHITE  
BIANCO

MD 88,4x39,5x39 cm  
∞ 2736 (x4) €/u

\*O



**SOPORTE PARA BUSTOS**  
*SUPPORT POUR BUSTE*  
*BUST SUPPORT*  
*SUPPORTO BUSTO*  
**\*2713/001**

Al 125 mm M8 €/u

\*O



**SOPORTE INCLINABLE ESTANTE**  
*SUPPORT INCLINABLE TABLETTE*  
*TILT BRACKET SHELF*  
*SUPPORTO INCLINABILE RIPIANO*  
**\*2720/001**

\*O



**SOPORTE INCLINABLE ESTANTE**  
*SUPPORT INCLINABLE TABLETTE*  
*TILT BRACKET SHELF*  
*SUPPORTO INCLINABILE RIPIANO*  
**\*2721/001**

\*O



**SOPORTE INCLINABLE FIJO**  
*SUPPORT INCLINABLE FIXE*  
*FIX TILT BRACKET*  
*SUPPORTO INCLINABILE FISSO*  
**\*2722/001**

\*O



**SOPORTE INCLINABLE REGULABLE**  
*SUPPORT INCLINABLE RÉGLABLE*  
*ADJUSTABLE TILT BRACKET*  
*SUPPORTO INCLINABILE REGOLABILE*  
**\*2723/001**

\*O



**BUSTO MUJER**  
*BUSTE FÉMME*  
*WOMAN BUST*  
*BUSTO DONNA*  
**\*2750/00B**

plas €/u

\*O

BLANCO  
BLANC  
WHITE  
BIANCO

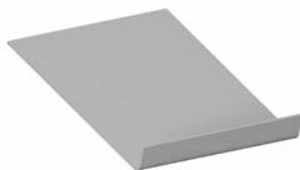

**ESTANTE METACRILATO**  
*TABLETTE MÉTHACRYLATE*  
*SHELF METHACRYLATE*  
*RIPIANO PLEXIGLASS*  
**\*2724/009**

BLANCO  
BLANC  
WHITE  
BIANCO

Al 300x400 mm  
4 mm €/u

\*O



**ESTANTE METACRILATO**  
*TABLETTE MÉTHACRYLATE*  
*SHELF METHACRYLATE*  
*RIPIANO PLEXIGLASS*  
**\*2725/009**

BLANCO  
BLANC  
WHITE  
BIANCO

Al 4 mm  
∅350 €/u

\*O

