

CATÁLOGO
DE PRODUCTOS

alusystem

**ALU
SYSTEM**

 **cotek.**



 **instal.**



 **metal.**

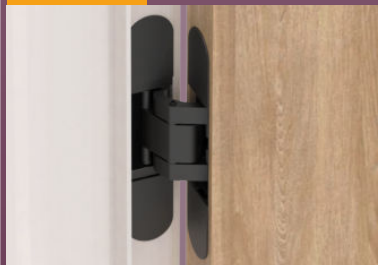

64
2025-26

ED.
10/25
Vigor:
01/10/25

PVP. Tarifa Venta al Público
Descuento según condiciones

PEDIDOS / ATENCIÓN AL CLIENTE

Teléfono +34 938 492 055 - Whatsapp +34 627 287 698
e-mail: pedidos@alusystem.es - www.alusystem.com

ACABADOS

- 00 BRUTO
- 01 ALUMINIO ANODIZADO PLATA MATE
- 02 ALUMINIO ANODIZADO PLATA BRILLO
- 03 ALUMINIO ANODIZADO ORO MATE
- 06 ALUMINIO ANODIZADO TIPO TITANIO
- 09 PLÁSTICO
- 22 ACERO INOXIDABLE PULIDO BRILLO
- 28 ACERO INOXIDABLE SATINADO
- 31 CROMO MATE
- 32 CROMO BRILLO
- 33 CROMO ORO BRILLO
- 35 CROMO ORO MATE
- 34 CINCADO
- 38 CROMADO SATIN NIKEL
- 0N NEGRO
- 0B BLANCO
- 0P PINTADO NO METALIZADO Y 9006

OTROS COLORES: CONSULTAR

FINITIONS

- 00 BRUT
- 01 ALUMINIUM ANODISÉ NATUREL MAT
- 02 ALUMINIUM ANODISÉ NATUREL BRILLANT
- 03 ALUMINIUM ANODISÉ DORÉ MAT
- 06 ALUMINIUM ANODISÉ TITANIUM
- 09 PLASTIQUE
- 22 INOX POLI
- 28 INOX SATINÉ
- 31 CHROMÉ MAT
- 32 CHROMÉ BRILLANT
- 33 CHROMÉ BRILLANT DORÉ
- 35 CHROMÉ MAT DORÉ
- 34 PLAQUÉ ZINC
- 38 SATIN NIKEL CHROMÉ
- 0N NOIR
- 0B BLANC
- 0P PEINTURE NON MÉTALLISÉE

AUTRES COULEURS: CONSULTER

FINISHES

- 00 RAW FINISH
- 01 ALUMINIUM ANODIZED NATURAL MATT
- 02 ALUMINIUM ANODIZED NATURAL BRIGHT
- 03 ALUMINIUM ANODIZED GOLD MATT
- 06 ALUMINIUM ANODIZED TITANIUM
- 09 PLASTIC
- 22 POLISHED STAINLESS STEEL
- 28 SATIN STAINLESS STEEL
- 31 MATT CHROME
- 32 BRIGHT CHROME
- 33 BRIGHT CHROME GOLD
- 35 MATT CHROME GOLD
- 34 ZINC PLATED
- 38 SATIN NIKEL CHROME
- 0N BLACK
- 0B WHITE
- 0P PAINTED NO METALIZED AND 9006

OTHER COLORS: CONSULT

FINITURE

- 00 GREZZO
- 01 ALLUMINIO ANODIZZATO NATURALE
- 02 ALLUMINIO ANODIZZATO NATURALE LUCIDO
- 03 ALLUMINIO ANODIZZATO DORATO
- 06 ALLUMINIO ANODIZZATO TITANIO
- 09 PLASTICA
- 22 INOX LUCIDO
- 28 INOX SATINATO
- 31 CROMO OPACO
- 32 CROMO LUCIDO
- 33 CROMATO DORATO LUCIDO
- 35 CROMATO DORATO OPACO
- 34 ZINCATO
- 38 CROMATO SATINATO NIKELATO
- 0N NERO
- 0B BIANCO
- 0P VERNICIE NO METALIZZATA

ALTRI COLORI: CONSULTARE

MEDIDAS

mesures - measures - misure



precio de 1 pieza
Prix pour 1 pièce
Price for 1 piece
prezzo per 1 pezzo



precio de 1 metro de perfil
prix d'un mètre de profil
price of 1 meter profile
prezzo di 1 metro di profilo



REFERENCIAS

item codes - références - codici articoli

4040/102

ref. artículo / item code / référence / codice articolo
barras / bars / barres / vergehe
acabado / finish / finitions / finitura

4041/032

ref. artículo / item code / référence / codice articolo
pieza / piece / pièce / pezzo
acabado / finish / finitions / finitura

1 = 1m facturación por metro lineal
billing per linear meter
facturation au mètre linéaire
fatturazione per metro lineare



2 = 2m
3 = 3m
4 = 4m
5 = 5m facturación por unidad
billing per unit
facturation par unité
fatturazione per unità



ABREVIATURAS

abréviations - abbreviations - abbreviazioni

20 kg/u peso max. rec.
max. weight rec.
poids max. rec.
carico mass.o rac.

L 5 m longitud
length
longueur
lunghezza

10-12 mm espesor
thickness
espesseur
spessore

∅ 15 mm taladro - avellanado
perforation - vis à tête fraisée
drill - countersunk screw
foratura - svasatura

∞ 2556 en unión con ...
en union avec ...
together with ...
insieme a ...

66 m en rollos
en rouleaux
in coils
in bobine

material / Al / aluminio - aluminium, alluminio
material / inox / s.s. / inox - stainless steel
material / Cu / latón - laiton, brass, ottone
material / Zn / zamak - zinc alloyed, zama
material / Fe / hierro - fer, iron, ferro
material / plas / plástico - plastique, plastic, plastica

muesca / encoche / cut-out / tacca
con - avec, with, con
sin - sans, without, senza

max./min. ↔ 100/160 ancho - largeur, width, larghezza

€ 125/190 alto - hauteur, height, altezza

ángulo de apertura / angle d'ouverture / opening angle / angolo d'apertura
0°-90°-180° punto de retención: en rojo
point de rétention: en rouge
retention point: in red
punto di ritenzione: in rosso

OBSERVACIONES

observations - remarks - osservazioni

REFERENCIAS CON ASTERISCO *:

hasta agotar existencias - consultar nuestro almacén para confirmar disponibilidad

Prix en rouge et en italique *:

jusqu'à épuisement du stock - consultez notre maga sin pour confirmer la disponibilité

references with asterisk *:

while stocks last - please consult our store to confirm availability

codici con asterisco *:

fino esaurimento stock - consultare il nostro magazzino per confermare la disponibilità



CALIDAD QUALITÉ - QUALITY - QUALITÀ

Según los datos proporcionados por los proveedores Alu System afirma:
 Selon les données fournies par les fournisseurs Alu System stipule:
 According to data provided by suppliers Alu System states:
 Secondo i dati forniti dai fornitori Alu System afferma:

HERRAJES COTEK

ACCESSOIRES COTEK - COTEK FITTINGS - ACCESSORI COTEK

Ensayo en niebla salina: TEST APROBADO

latón y zamak : 240 h en solución al 5% NaCl
 aluminio 120 horas en solución al 5% NaCl
 acero inox: piezas en 304: en raros casos se han detectado
 pequeñas microincrustaciones superficiales (en ambiente
 extremadamente agresivos); pieza en 316: no se han detectado
 problemas

Test de brouillard salin: TEST APPROUVÉ

pièces en laiton et zamak: 240 h dans une solution de NaCl à 5%
 aluminium: 120 h dans une solution de NaCl à 5%
 Acier inoxydable: pièces en 304: dans de rares cas ont été détectés petite surface micro
 échelle (en environnement très agressif); pièces en 316: Aucun problème n'a été détecté

Salt spray test: APPROVED TEST

brass and zinc alloyed items: 240 h in 5% NaCl solution
 aluminium: 120 h in 5% NaCl solution
 Stainless steel 304 pieces: in rare cases have been detected small micro-inlays surface
 (in very aggressive environment); Stainless steel 316: no problems detected

Test di nebbia salina: TEST APPROVATO

articoli in ottone e zamak: 240 h in soluzione al 5% NaCl
 alluminio: 120 h in soluzione al 5% NaCl
 Acciaio inossidabile: articoli in 304: raramente si sono riscontrate piccole microincrostazioni
 superficiali (in ambienti estremamente aggressivi); articoli in 316: non sono stati riscontrati
 problemi

PERFILES DE ALUMINIO

PERFILES D'ALUMINIUM - ALUMINIUM PROFILES - PROFILI IN ALLUMINIO

Aleación de aluminio, alliage d'aluminium, aluminum alloy, lega di alluminio:
 6063-T5

Anodización, anodisation, anodizing, anodizzazione:

standard 6-8 mc.

Delphos: 15 mc.

PINTURA

PEINTURE - PAINTING - VERNICIATURA

Los productos pintados en epoxi/poliéster tienen un espesor medio de 80-90 mc.

Produits peints epoxy/polyester ont une épaisseur moyenne de 80 à 90 mc.

Painted products epoxy/polyester have an average thickness of 80-90 mc.

Prodotti verniciati in epossidico/poliesteri hanno uno spessore medio di 80-90 mc.

¡¡¡IMPORTANTE! IMPORTANT! IMPORTANTE!

MUESCAS, ENCOCHES, CUT-OUT, TACCHE

1. Herrajes que necesitan mecanización del cristal: se recomienda comprobar las medidas de los taladros y las muescas con los herrajes en la mano, antes de proceder a la mecanización.

Quincaillerie besoin mécanisation de verre: Il est recommandé de vérifier les dimensions des trous et encoches avec le matériel en main, avant la mécanisation.

Hardware needing mechanization of glass: It is recommended to check the dimensions of the holes and cut-out with the hardware in hand, before proceeding to mechanization.

Accessori che richiedono la meccanizzazione del vetro: Si consiglia di verificare le dimensioni dei fori e delle tacche con l'articolo in mano, prima della meccanizzazione.

2. Los dibujos son indicativos y no constituyen ninguna vinculación contractual.

Les dessins sont à titre indicatif et ne constituent pas une relation contractuelle.

The drawings are indicative and do not constitute any contractual relationship.

I disegni sono indicativi e non costituiscono alcun rapporto contrattuale.

3. Alu System se reserva el derecho de efectuar modificaciones sin previo aviso en las características de los productos presentados en el catálogo. Así mismo, Alu System no asume la responsabilidad de los cambios introducidos en los productos por el fabricante de los mismos.

Alu System se réserve le droit d'apporter des modifications sans préavis les caractéristiques des produits dans le catalogue. De même, Alu System assume aucune responsabilité pour des changements dans les produits par le constructeur.

Alu System reserves the right to make changes without notice in the characteristics of the products in the catalog. Likewise, Alu System assumes no responsibility for changes made in the products by the manufacturer.

Alu System si riserva il diritto di apportare modifiche senza preavviso alle caratteristiche dei prodotti in catalogo. Allo stesso modo, Alu System non si assume alcuna responsabilità per cambiamenti introdotti nei prodotti da parte dello stesso produttore.

MANTENIMIENTO, MAINTENANCE, MANTENANCE, MANUTENZIONE

4. Limpiar las piezas cromadas sólo con agua y con jabón neutro. Alu System no se responsabiliza de daños provocados por uso de productos de limpieza indebidos.

Nettoyez les pièces chromées uniquement avec de l'eau et du savon doux. Alu System ne est pas responsable des dommages causés par une mauvaise utilisation de produits de nettoyage.

Clean chrome parts only with water and mild soap. Alu System is not responsible for damage caused by improper use of cleaning products.

Pulire le parti cromate solo con acqua e sapone neutro. Alu System non è responsabile per i danni causati da un uso improprio dei prodotti per la pulizia.

SUSTITUCIÓN, REPLACEMENT, SOSTITUZIONE

5. En caso de sustitución de productos, Alu System se hace cargo del material y del transporte pero no de la mano de obra de sustitución.

En cas de remplacement des produits, Alu System prend soin de matériaux et le transport, mais pas la substitution du travail

In case of replacement of products, Alu System takes care of materials and transport but not labor substitution

In caso di sostituzione di prodotti, Alu System si fa carico del materiale e del trasporto, però non della mano d'opera della sostituzione.

CATÁLOGO, CATALOGUE, CATÁLOGO

6. Alu System no se responsabiliza de posibles errores de tipografía o de imprenta.

Alu System ne est pas responsable des erreurs typographiques ou d'impression

Alu System isn't responsible for any errors in typography or printing.

Alu System non è responsabile per eventuali errori tipografici o di stampa.

7. Derechos reservados. No se autoriza ninguna reproducción total o parcial de la tarifa sin previa autorización por parte de Alu System.

Tous les droits sont réservés. Tout reproduction totale ou partielle est interdite sans autorisation préalable du Alu System

All rights reserved. Any full or partial reproduction is not permitted without prior authorization from Alu System

Tutti i diritti sono riservati. Qualsiasi riproduzione totale o parziale non è consentita senza previa autorizzazione di Alu System.

cotek.

DUCHA

CORREDERAS DUCHA

- | | | | |
|----|----------------|----|--------|
| 6 | GAMA PREMIUM | 20 | VERONA |
| 8 | NEMO SOFT | 22 | OSLO |
| 8 | NEMO SOFT MINI | 24 | NICOLE |
| 10 | NEMO PLUS | 26 | BEGUR |
| 16 | NEMO | 27 | CANNES |
| 18 | VERONA CUADRO | 28 | CUADRO |
| | | 34 | TONDO |

cotek.

DUCHA

BISAGRAS Y HERRAJES

- | | | | |
|----|------------------------|----|--------------------------------|
| 38 | GAMA PREMIUM | | LISBOA |
| | BISAGRAS | | VENECIA |
| 40 | BISAGRAS CON RETENCIÓN | | MONACO |
| | TEIDE | | VALENCIA, CURVO Y JEREZ |
| | MALLORCA PLUS | 43 | HERRAJES FIJOS |
| | MALLORCA | 44 | PERFILES FIJOS - PERFIL CANNES |
| | MALLORCA REGULABLE | 44 | BARRAS DE REFUERZO |
| | IBIZA | 45 | PORTAESTANTES |
| | LANZAROTE | 45 | DISTANCIADORES SUELO |
| | MALLORCA HIDRÁULICA | 45 | CIERRES LAVABOS |
| | TENERIFE | 46 | PERIMETRALES |
| | LUGO | 48 | POMOS, TIRADORES Y UÑEROS |
| | MENORCA REGULABLE | 48 | TOPES, TOALLEROS Y |
| | MENORCA | 48 | PORTAROLLOS |
| | BILBAO | 50 | TAPAJUNTAS |
| | ALICANTE | 52 | TIVOLI |
| | NIZA PLUS | 54 | ROMA QUADRANT |
| 42 | BISAGRAS SIN RETENCIÓN | 54 | ROMA |
| | NIZA | 55 | ARNO |

cotek.

PUERTAS

KITS PUERTAS CORREDERAS

- | | | | |
|----|---------------------------|-----|---------------------|
| 58 | GAMA PREMIUM | 84 | KYOTO |
| | PANAMÁ AUTOMÁT. MAGNÉTICA | 86 | SERENA |
| 60 | FAMILIA CANTÓN | 88 | SYNCRO |
| 62 | CANTÓN VIDRIO | 90 | TELEX 2 |
| 64 | CANTÓN MARCO | 92 | TELEX 3 |
| 68 | CANTÓN MARCO INVISIBLE | 94 | PLATEK Inox |
| 70 | CANTÓN MARCO TELEX 2 | 96 | TOKYO |
| 72 | CANTÓN MARCO TELEX 3 | 97 | SHANGHAI |
| 76 | CANTÓN MARCO TELEX MOVE | 98 | PISA |
| 80 | CANTÓN MARCO PIVOTANTE | 104 | MONZA |
| | | 106 | RIMINI |
| | OTROS KITS | 110 | PLEGABLE |
| 82 | KOBE | 112 | PLEGABLE DESPLAZADA |
| | | 114 | APILPLUS |

cotek.

PUERTAS

HERRAJES PUERTAS ABATIBLES

- | | | | |
|-----|---|-----|-----------------------------|
| 118 | GAMA PREMIUM | | MARINA |
| 120 | PIVOTANTE SIENA | | LYON |
| 120 | FRENO AMSTERDAM | | VIENA |
| 120 | FRENO MIAMI | | GALICIA |
| 121 | FRENO BOSTON | | BONN |
| 121 | FRENO PRAGA | | |
| 121 | FRENO OPORTO | | |
| 122 | FRENOS Y BISAGRAS HIDRÁULICAS Y AUTOMÁTICAS - | 126 | DIVISORIAS |
| | RIO HIDRÁULICA | 127 | PERFILES SELLADORES PUERTAS |
| | ATLANTA | 127 | HERRAJES FIJOS |
| | MALLORCA HIDRÁULICA | | |
| | ZURICH | 128 | GAMA PREMIUM |
| | SUIZA | | SMART-LOCKS |
| | GAUDÍ | 128 | CERRADURAS - |
| | VERNA | | CERRAD. MAGNÉTICAS |
| | LUGO | | CERRAD. CORREDERAS |
| | MENORCA | | CIERRE LAVABOS MANILLA |
| 124 | FRENOS Y BISAGRAS - | | MONTSE |
| | FRENOS IMPORTACIÓN | | MÓNICA |
| | PLINTO | | SONIA |
| | MÁLAGA | | MARTA |
| | | 130 | TIRADORES, POMOS Y UÑEROS |

cotek.

BARANDILLAS

HERRAJES

- | | | | |
|-----|--|-----|---------------------------------|
| 134 | GAMA PREMIUM
SOPORTE CON LUZ LED | 140 | PINZAS PARA BARANDILLAS |
| 136 | DISTANCIADOR DUPLEX | 141 | DISTANCIADORES |
| 137 | SOPORTES BARANDILLA
DUPLEX-TILT-LOCK 5942 / 5941 / 1437 | 141 | DISTANCIADORES ESCALERAS VIDRIO |
| | | 142 | SOPORTES VIDRIO |
| 138 | HERRAJES PARA PISCINA | 142 | PERFILES PASAMANOS |
| 139 | SOPORTES BARANDILLA SUELO | 143 | DELPHOS |
| 139 | REFUERZO PARA BARANDILLAS | 144 | MARQUESINAS |
| 139 | UTILAJES ALINEACIÓN DEL VIDRIO | 144 | MINI CRUCETAS |
| | | 145 | VENTOSAS |
| | | 145 | ACCESORIOS VIDRIO |

metal.

METAL

HERRAJES VIDRIO Y MADERA

- | | | | |
|-----|----------------------------------|-----|---|
| 148 | KARR 1 Y KARR 3 | 170 | LIMA |
| 150 | CORREDERA PLÁSTICO | 171 | MATEK |
| 150 | "U" Y "L" | | |
| 150 | CERRADURAS VITRINAS | | GAMA PREMIUM |
| 151 | BISAGRAS VITRINAS | 172 | FH9 - BISAGRA HIDRÁULICA OCULTA
MADERA |
| 152 | PORTAESTANTES | | |
| 153 | COMPLEMENTOS | 174 | FH10 - BISAGRA HIDRÁULICA |
| 153 | DIS-PLAY | 176 | FH6 - BISAGRA HIDRÁULICA |
| 154 | CLICK | 177 | FH5 - BISAGRA HIDRÁULICA |
| 156 | FACILPLUS Y ARPLUS | 178 | FH3 - AMORTIGUADOR HIDR. OCULTO |
| | | 180 | AH8 - AMORTIGUADOR HIDR. OCULTO |
| | GAMA PREMIUM | 182 | AH7 - AMORTIGUADOR HIDR. |
| 158 | PANAMÁ AUTOM. MAGN. MADERA | 184 | SH1 - STOP HIDR. UNIVERSAL |
| 162 | PANAMÁ INVISIBLE MAGN. MADERA | | |
| 164 | FAMILIA CANTÓN - | 186 | B150 - BISAGRA OCULTA |
| 164 | CANTÓN INVISIBLE MADERA (MANUAL) | 187 | SMART-LOCKS MADERA
HIDRO |
| 164 | CANTÓN MADERA | | |
| 166 | CANTÓN TELEX MADERA 2 | | |
| 168 | CANTÓN TELEX MADERA 3 | | |

instal.

ILUMINACIÓN

SIST. ILUMIN. ECO.



- | | | | |
|-----|---|-----|--|
| 189 | KADÍ CREMALLERA ELEKTRIC
EXPLOSIONADO GENERAL
MONTAJE EN SERIE
MONTAJE ELÉCTRICO
MONTAJE PLAFONES
MONTAJE CREM. ELEKTR.
(ESQUEMA) ACCES.PRIMO
TABLA DE PESOS
COMPORTAMIENTO PESOS
PLUG & PLAY
DESPIECE ACCESORIOS
COMPONENTES POR PIEZA
COMP. FACIL CONEXIÓN
ACCES. CON COMPON. | 226 | KADÍ PRIMO ELEKTRIC
EXPLOSIONADO GENERAL
MONTAJE EN SERIE
MONTAJE CON MAGNETIC
MONTAJE CON EASY
INF. TOPE, GRAPAS, CABLE
INF. CARRIL ELÉCTRICO
INF. CONECTOR
INF. CARRIL-CABLE
(ESQUEMA) ACCES.PRIMO
TABLA DE PESOS
COMPORTAMIENTO PESOS
PLUG & PLAY
COMPONENTES POR PIEZA
COMP. FACIL CONEXIÓN
ACCES. CON COMPON. |
| 208 | KADÍ PHARMA ELEKTRIC
EXPLOSIONADO GENERAL
MONTAJE EN SERIE
MONTAJE CON MAGNETIC
MONTAJE CON EASY
MONTAJE PLAFONES
INF. TOPE, GRAPAS, CABLE
INF. CARRIL ELÉCTRICO
INF. CONECTOR
INF. CARRIL-CABLE
(ESQUEMA) ACCES.PRIMO
TABLA DE PESOS
COMPORTAMIENTO PESOS
PLUG & PLAY
COMPONENTES POR PIEZA
COMP. FACIL CONEXIÓN
ACCES. CON COMPON. | 242 | SITEMA CUT-LINE
PERFILES ILUMINACIÓN Y LEDS |
| | | 243 | EASY LIGHT - MAGNETIC LED
SITEMA
COMPONENTES |
| | | 244 | EASY LIGHT - EASY
SITEMA
COMPONENTES |
| | | 248 | SISTEMA VARIO
COMPONENTES |

instal.

KADÍ

SISTEMAS SIN ILUMINACIÓN

- 252 **KADÍ CREMALLERAS**
KADÍ OMEGA
KADÍ ALA
KADÍ CLASSIC
KADÍ HIERRO EMPOTRABLE
KADÍ EMPOTRABLE ALUM.
KADÍ DUO
- 258 **KADÍ CREMALLER. COMPONENTES**
KADÍ EMPOTRABLE ALUM.
KADÍ COLUMNA
KADÍ VÉRTICE
BOTONES PLÁST. PANELAD.
KADÍ OMEGA
KADÍ ALA
KADÍ DUO
KADÍ HIERRO EMPOTRABLE
- 260 **KADÍ TUBULAR**
261 **KADÍ CARTELAS**
262 **CAPACIDAD DE CARGA**
CARTELAS EMPOTRABLE
CARTELAS "SILUETTE"
CARTELAS SILUET. INCLIN.
CABALL. ESTANTE CARTEL.
CARTELAS "TIBURÓN"
CARTELAS PASANTES
CARTEL. PASANT. ACCES.
ACCESORIOS TUBO OBAL.
PERROQUETES
- 266 **PERFIL PARA SIST. KADÍ Y LAMAS**
268 **KADÍ COLUMNAS**
VERONA
BILBO
MILÁN
ACCESORIOS - COMPLEM.
- 270 **KADÍ PHARMA DUO SISTEMA**
CORTE DE LA MADERA
COLUMNAS TROQUELAD.
COMPONENTES PHARMA
COMPONENTES PHARMA DUO
- 276 **MULTILAMA**
276 **PHARMA + MULTILAMA**
277 **SEPARADORES Y PORTA PRECIOS**
- 278 **KADÍ PRIMO 25X25**
NUDOS A PRESIÓN
NUDOS BRIDA
TAPONES
TUBO 25X25
ACCESORIOS
EJEMPLOS DE MONTAJE
- SIST. CUELQUE DE MUEBLES

instal.

LAMAS

SISTEMAS SIN ILUMINACIÓN

- 286 **SISTEMA LAMAS**
PANELES Y PERFILES
- 288 **SISTEMA LAMAS 361**
289 **LAMAS - "INVISIBLE"**
290 **LAMAS - CASQUILLO**
291 **LAMAS - "INVISIBLE" 403**
292 **LAMAS - DM**
- 293 **LAMAS - ALUMINIO**
294 **ACCESORIOS LAMAS**
296 **PARALELO 384**
298 **OPTI 3**

instal.

MULTILAMAS
Y VERTICAL

SISTEMAS COMPATIBLES

- 302 **MULTILAMA**
MONTAJE
INFORMACIÓN TÉCNICA
COMPONENTES
REMATE LATERAL
COMPONENTES
ACCESORIOS SOLO MULTILAMA
ANGULOS Y "US"
- 306 **VERTICAL**
INFORMACIÓN TÉCNICA
MONTAJE
COMPONENTES
GÓNDOLAS
ACCESORIOS GÓNDOLAS
ACCESORIOS COMUNES
MULTILAMA

instal.

OTROS

OTROS SISTEMAS SIN ILUMINACIÓN

- 316 **STAR 25**
318 **STAR 8**
319 **ÇABLE DECO**
320 **ÓPTICA**
EXPOSITORES PARA GAFAS
OPTI 3
PARALELO 384
- 324 **STENDERS**
324 **PROBADORES**
325 **MALLAS**
326 **BASIC - LOW COST**
BASIC MAXI
BASIC MINI
- 330 **CONCEPT -LOW COST**
- 322 **JS-25**



cotek.

DUCHA

CORREDERAS DUCHA

GAMA PREMIUM

**HERRAJES ALTA GAMA -
NEMO SOFT**
KITS Y COMPONENTES

**HERRAJES ALTA GAMA -
NEMO SOFT MINI**
KITS Y COMPONENTES

**HERRAJES ALTA GAMA -
NEMO PLUS**
DATOS GENERALES
INSTALACIÓN
KITS Y COMPONENTES

NEMO
KITS Y COMPONENTES

VERONA CUADRO
KITS Y COMPONENTES

VERONA
KITS Y COMPONENTES

OSLO
KITS Y COMPONENTES

NICOLE
KITS Y COMPONENTES

BEGUR

CANNES

CUADRO
DATOS GENERALES
INSTALACIÓN
KITS Y COMPONENTES

TONDO
KITS Y COMPONENTES

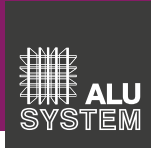

MAMPARA NEMO SOFT

**BASADO EN EL SISTEMA NEMO
CON SOFT-CLOSING (CIERRE AMORTIGUADO)**

KITS

NEMO SOFT / 1 PUERTA + FIJO 180°

ON 32



MAMPARA NEMO SOFT
(CON SOFT-CLOSING)

Écran à fermeture douce
Shower screen with soft-closing
Schermo con chiusura rallentata

6-8 mm Max. 60 Kg/Puerta

Sistema basado los herrajes comunes del sistema de la familia Nemo. Nueva gama de mamparas con self-closing (con auto cierre y amortiguador de golpe) insertado en la parte superior. (Vidrios 8mm hasta 40 kg de peso/puerta).

€/u. Al Cu 5175/B.. KIT 180°

€/u. Al Cu 5176/B.. KIT 90°

Se sirve sin vidrio

NOVEDAD

COMPONENTES:

KIT 180° 5175/B.. componentes:	- (1U) 5170/2.. - 2M - (1U) 5171	- (X2) 4043 - (X2) 4044 - (X1) 4046	- (X1) 4114 - (1U) 1851 - 2,2 M (8mm)
KIT 90° 5176/B.. componentes:	- (1U) 5170/2.. - 2M - (1U) 5171	- (X2) 4043 - (X1) 4030 - (X2) 4044	- (X1) 4046 - (X1) 4114 - (1U) 1851 - 2,2 M (8mm)

CARACTERÍSTICAS
PRINCIPALES

- Vidrio sin muescas
- Carril sin mecanización
- Montaje fácil y rápido
- Vidrio recomendado 8mm

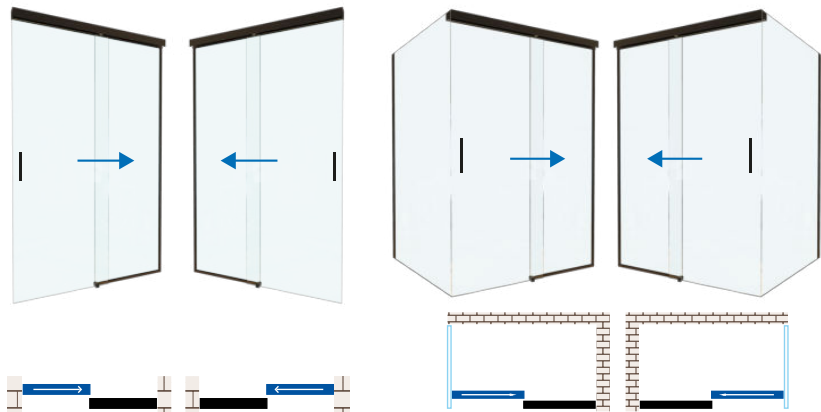

5175/B..

5176/B..



COMPONENTES NEMO SOFT

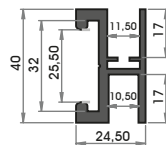

CARRIL

Rail
Track
Guida

€/u. Al 5170/2.. 2M

€/u. Al 5170/3.. 3M



SET 2 COJINETES + 2 BUFFERS

NEMO SOFT

Chariot
roller
cuscinetto

€/u. Inx 5171/S..

NEGRO NOR BLACK NERO	PL. BR ALU. BR ALU. BR ALL. LUC	INOX BR INOX POLI P.S.S. INOX. LUC
ON	02	22
○	○	○
○	○	○
∅ 21 mm	6-8 mm	50 Kg/set.
○	○	○

COMPONENTES NEMO



ANCLAJE CARRIL-PARED

fixation mur-coulisse
connexion wall-track
connessione parete-guida

Cu 4043/0.. €/u.



GUÍA SUELO

guidage au sol
floor guide
guida a pavimento

Cu 4046/0.. €/u.

NEGRO NOR BLACK NERO	CR. BRILLO CHR. POLI BR. CHR CR. LUC.
ON	32
○	○
○	○
	6-8 mm

COMPONENTES NEMO PLUS
(PARA 90°)



CONEXIÓN 90° CARRIL - VIDRIO FIJO
PARA NEMO PLUS 90° SIN TAPA (4039)

Fixation verre-coullisse (sans 4039)
Connexion glass-track (without 4039)
Connessione vetro-guida (senza 4039)

Pla **4030/0..** €/u.



STOP INTERIOR CARRIL

stop chariot
stop roller
stop cuscinetto
Cu **4044/0..** €/u.

NEGRO NOIR BLACK NERO	CR. BRILLO CHR. POLI BR. CHR CR. LUC.
ON	32

COMPONENTES
UNIVERSALES

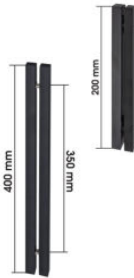

TIRADOR 20 CM

Poignée 20 cm
Handle 20 cm
Maniglia 20 cm
Al **4114/0..** €/u.

TIRADOR 40 CM

Poignée 40 cm
Handle 40 cm
Maniglia 40 cm
Al **5129/0..** €/u.



POMO

poignée
knob
pomo
Cu **4047/0..** €/u.



"U" ALUMINIO

u aluminium
u aluminium
u alluminio
Al **1659/10N** €/m
5m / 15x15x15x1,5
Al **1657/10N** €/m
6m / 12x12x12x1,5



"U" INOX PULIDO

u inox poli
u polished stainless steel
u inox lucido
lx **4375/122** €/m
15x15x15x1
lx **4376/122** €/m
15x12x15x1
lx **4377/122** €/m
25x15x25x1



PERFIL LATERAL CORREDERA

prof. étancheité coulissant
sliding door seal
giunta porta scorrevole
Pvc **1851/109** €/m

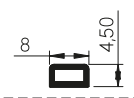

TAPAJUNTA ADHESIVO 2,5 M

profil étancheité adhesive 2,5m
adhesive seal 2,5 m
giunta adesiva 2,5 m
€/M Pla **1811/109**



PERFIL BURLETE DE ALUMINIO

profilte levre-up
lip-up profile
profilo verticacque
Al **1831/202** €/u.
Al **1831/20N** €/u.

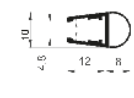

PERFIL MAMPARAS

prof. étancheité
seal
giunta
Pvc **1830/1..** €/u.

NEGRO NOIR BLACK NERO	PL. BR ALU. BR ALU. BR ALL. LUC	CR. BRILLO CHR. POLI BR. CHR CR. LUC.
ON	02	32

6-8 mm 2 x Ø8mm
20 cm CC=145mm

6-8 mm 2 x Ø8mm
40 cm CC=350mm

6-8 mm Ø 10 mm

INOX INOX P.S.S INOX LUC	BR POLI S	PLÁSTICO PLASTIQUE PLASTIC PLASTICA
22	09	

max. 10 mm

max. 8 mm

max. 12 mm

max. 8 mm

max. 12 mm

8 mm 2,2 M

2,5 M 8-10 mm

PL. BR ALU. BR ALU. BR ALL. LUC	NEGRO NOIR BLACK NERO
02	ON

PLÁSTICO
PLASTIQUE
PLASTIC
PLASTICA

6-8 mm 2,2 M

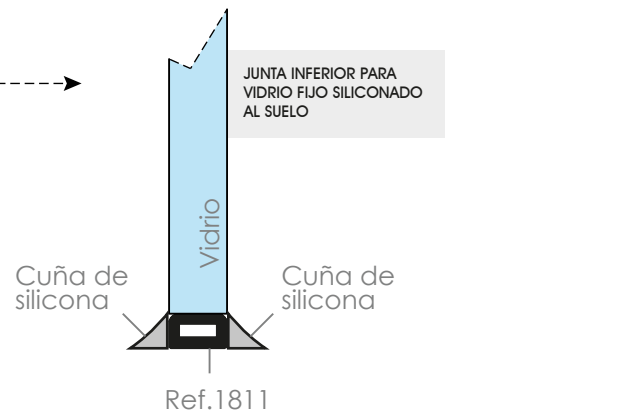
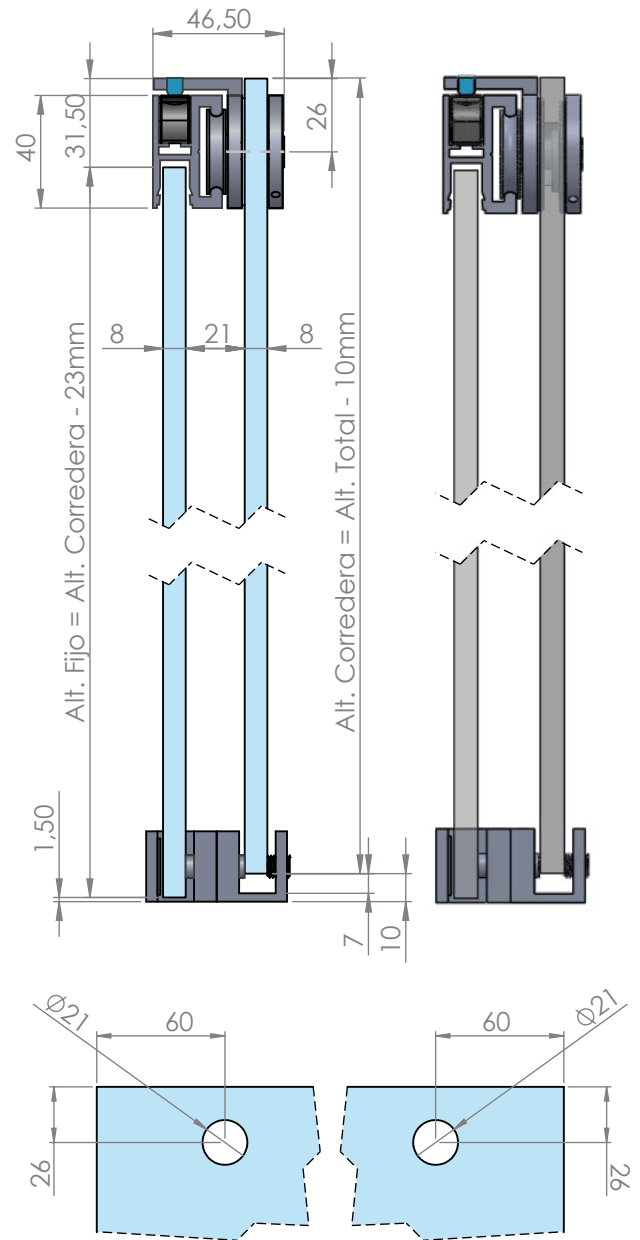

MAMPARA NEMO SOFT MINI

BASADO EN EL SISTEMA NEMO
CON SOFT-CLOSING (CIERRE AMORTIGUADO)

KITS

NEMO SOFT MINI/ 1 PUERTA + FIJO 180°

ON 32 OP



MAMPARA NEMO SOFT 180°
(CON SOFT-CLOSING)

Écran à fermeture douce
Shower screen with soft-closing
Schermo con chiusura rallentata

MAMPARA NEMO SOFT 180°
1 PUERTA + FIJO (CON SOFT-CLOSING)

Écran à fermeture douce
Shower screen with soft-closing
Schermo con chiusura rallentata

Se sirve sin vidrio

6-8 mm Max. 40 Kg/Puerta
Sistema basado los herrajes comunes del sistema de la familia Nemo. Nueva gama de mamparas con self-closing (con auto cierre y amortiguador de golpe) insertado en la parte superior. (Vidrios 8mm hasta 40 kg de peso/puerta).

€/u. Al Cu 5185/B..
KIT 180°

€/u. Al Cu 5186/B..
KIT 90°

ON	32	OP
<input type="radio"/>	<input type="radio"/>	<input type="radio"/>
<input type="radio"/>	<input type="radio"/>	<input type="radio"/>

NOVEDAD

COMPONENTES:

KIT 180° 5185/B.. componentes:	- (1U) 5180/2.. - 2M - (1U) 5181	- (X1) 4114 - 5183/00P - (1U) 1839 - 2,2 M (8mm)
KIT 90° 5186/B.. componentes:	- (1U) 5180/2.. - 2M - (1U) 5181 - (1U) 5282	- (X1) 4114 - 5183/00P - (1U) 1839 - 2,2 M (8mm) - (x2,2) 1833 - 2,2 M

CARACTERÍSTICAS PRINCIPALES

- Vidrio sin muescas
- Carril sin mecanización
- Montaje fácil y rápido
- Vidrio recomendado 8mm

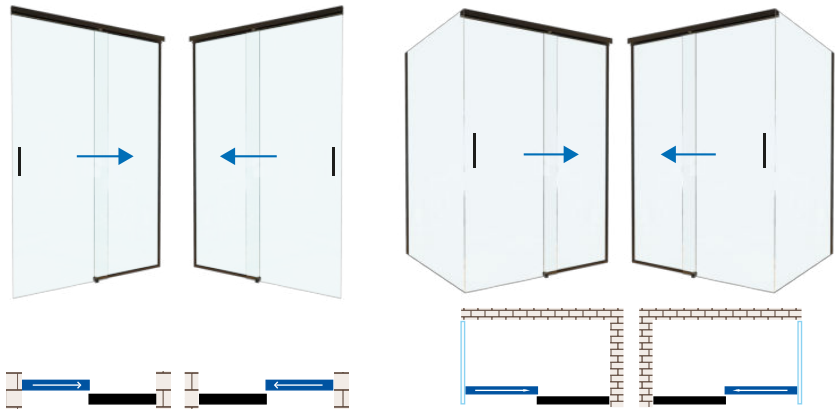

5185/B..

5186/B..



COMPONENTES NEMO SOFT

CARRIL
Rail
Track
Guida
€/u. Al 5180/2..
2M

KIT 2 COJINETES + 2 BUFFERS + CONECTORES CARRIL-PARED + GUADOR DE SUELO
Kit 2 roulements + 2 butées + connecteurs rail-mur + guide au sol
Kit 2 bearings + 2 buffers + rail-wall connectors + floor guide
Kit 2 cuscinetti + 2 tamponi + connettori traversa-parete + guida a pavimento
€/u. Cu 5181/S..

ABRAZADERA PARA VIDRIO FIJO 90°
Pince pour verre fixe à 90°
Clamp for 90° fixed glass
Morsetto per vetro fisso a 90°
€/u. Cu 5182/0..

NEGRO NOR BLACK NERO	COLOR COULEUR COLOR COLORE	PL. BR. ALU. BR ALU. LUC. ALL. LUC.
ON	OP	02
STOCK ORO MATE		
<input type="radio"/>	<input type="radio"/>	<input type="radio"/>
<input type="radio"/>	<input type="radio"/>	<input type="radio"/>
<input type="radio"/>	<input type="radio"/>	<input type="radio"/>
<input type="radio"/>	<input type="radio"/>	<input type="radio"/>

21 mm 6-8 mm 40 Kg/set.

CR. BRILLO
CHR. POLI
BR. CHR
CR. LUC.
32

**COMPONENTES
UNIVERSALES**

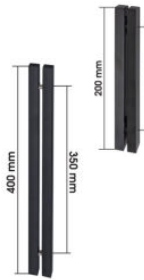

TIRADOR 20 CM

Poignée 20 cm
Handle 20 cm
Maniglia 20 cm
Al **4114/0..** €/u.

TIRADOR 40 CM

Poignée 40 cm
Handle 40 cm
Maniglia 40 cm
Al **5129/0..** €/u.

POMO

poignée
knob
pomo
Cu **4047/0..** €/u.

POMO

poignée
knob
pomo
Cu **5183/00P** €/u.

"U" ALUMINIO

u aluminium
u alluminium
u aluminio

Al **1659/10N** €/m

5m / 15x15x15x1,5

Al **1657/10N** €/m

6m / 12x12x12x1,5

"U" INOX PULIDO

u inox poli
u polished stainless steel
u inox lucido

lx **4375/122** €/m

15x15x15x1

lx **4376/122** €/m

15x12x15x1

lx **4377/122** €/m

25x15x25x1

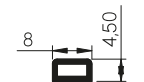

TAPA JUNTA ADHESIVO 2.5 M

profil étanchéité adhesive 2,5 m
adhesive seal 2,5 m
giunta adesiva 2,5 m

€/M Pla **1811/109**



PERFIL BURLETE DE ALUMINIO

profile levre-up
lip-up profile
profilo verticacque

Al **1831/202** €/m

Al **1831/20N** €/m



PERFIL MAMPARAS

prof. étanchéité
seal
giunta

Pvc **1830/109** €/m

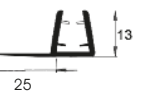

PERFIL LATERAL CORREDERA

PROF. ÉTANCHÉITÉ COULISSANT
SLIDING DOOR SEAL
GIUNTA PORTA SCORREVOLE

1839/2.. €/u.

COLOR COULEUR COLOR COLORE	NEGRO NOR BLACK NERO	PL. BR ALU. BR ALU. BR ALL. LUC	CR. BRILLO CHR. POLI BR. CHR OR. ILLC.
0P	0N	02	32
		6-8 mm	2 x Ø8mm CC=145mm
		20 cm	
		6-8 mm	2 x Ø8mm CC=350mm
		40 cm	
		6-8 mm	10 mm
		6-8 mm	10 mm
		INOX P.S.S. INOX. LUC	BR POLI LUC
		22	09
			5/6 M
			max. 10 mm
			max. 8 mm
			3 M
			max. 12 mm
			max. 8 mm
			max. 12 mm
			2,5 M
			8-10 mm
		PL. BR ALU. BR ALU. BR ALL. LUC	NEGRO NOR BLACK NERO
		02	0N
			2M
		PLÁSTICO PLASTIQUE PLASTIC PLASTICA	
		09	
		6-8 mm	2,2 M
		pvc	2,2m
			8-10mm
			€/u

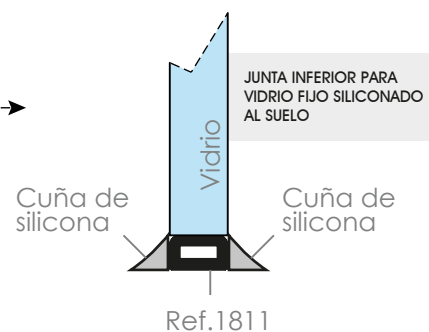
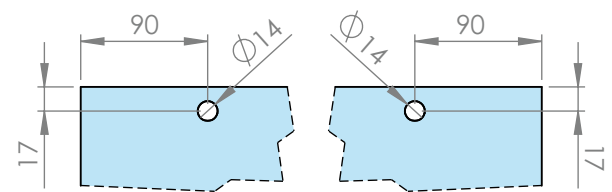
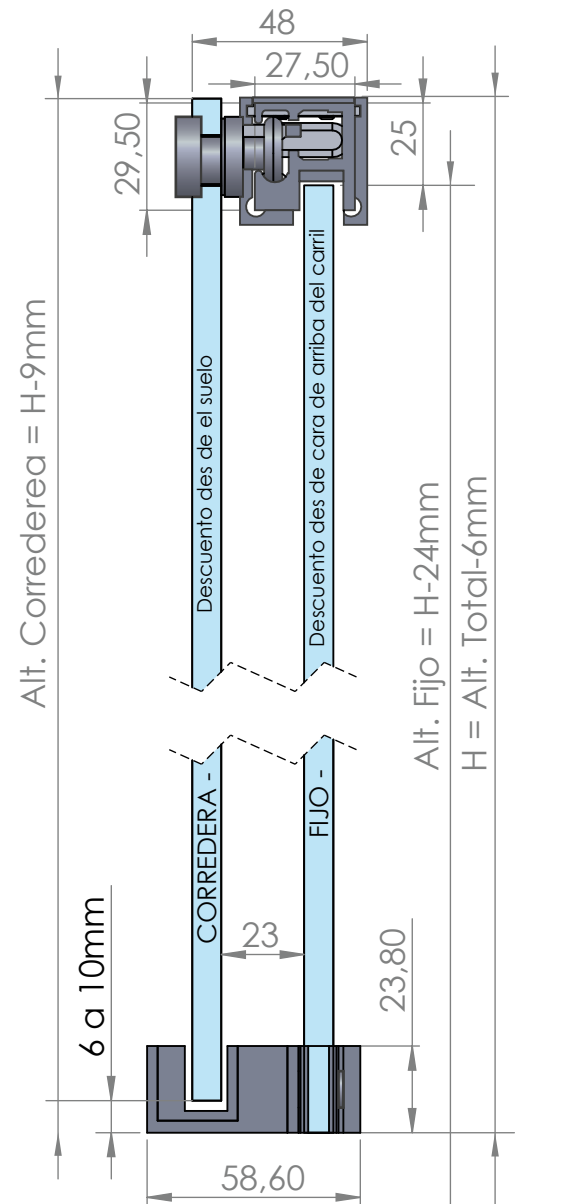

Ref.1811

MAMPARA NEMO PLUS

BASADO EN EL SISTEMA NEMO
CON ILUMINACIÓN OPCIONALLAS FORMAS
BORDES Y DIBUJOS
SE ILUMINAN
CON EL LED

- LOGOTIPOS
- DEGRADADOS
- DIBUJOS
- SANEFAS

Con técnicas como el ácido o el chorreado de arena, este sistema consigue resaltar creando una diferenciación que potencia la imagen de marca, creando patrones reconocibles, creando impacto en la experiencia de usuario y una ilusión visual que crea una ambientación ideal para momentos relajantes.

¿QUÉ APORTA?

MÁS SENCILLEZ
EN EL MONTAJE

- ✓ VIDRIO FIJO
SIN MUESCA
- ✓ CARRIL
SIN MECANIZACIÓN
- ✓ FÁCIL
MONTAJE
- ✓ VIDRIO
8MM

SIN TAPA

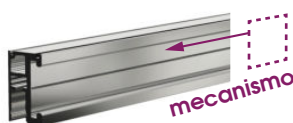

CON TAPA



- Carril sin ningún tipo de mecanizado.
- Se puede combinar con el perfil 4039, dejando los mecanismos ocultos para un acabado premium.



- Posibilidad de colocar vidrio laminado en el fijo, ya que no necesita ser mecanizado.



LA ÚNICA MAMPARA CON LUZ INCORPORADA

CREA AMBIENTACIONES
CON LUZ BLANCA
O DE COLORES

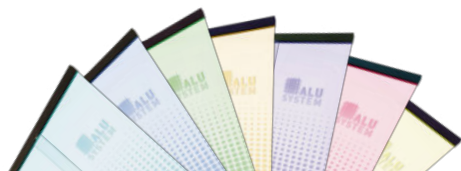

LEDs con control remoto, con rueda de colores, con posibilidad de crear diferentes bucles de color, colores fijos personalizados y variación de potencia de luz.

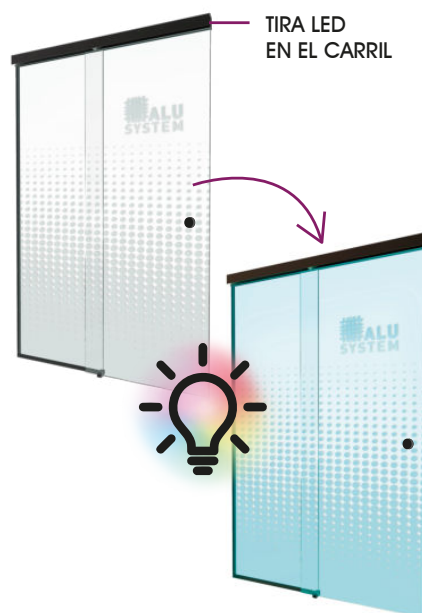

DATOS GENERALES

ACABADOS



VIDRIO

Puerta de vidrio /
Cariles en aluminio
plata y negro.

Vidrio de 6-8 mm

* Para otros acabados,
consultar pedido mínimo
y plazo de entrega.

PESO

PESO PUERTAS
180° / 90° + FIJO



40 Kg/puerta
peso max.

CARACTERÍSTICAS



ILUMINACIÓN LED:

- PARA CREAR AMBIENTES,
PROMOVER IMÁGEN DE MARCA Y
PATRONES RECONOCIBLES, IMPACTO
VISUAL O CREAR ESTÉTICAS
ESPECIALES PARA UNIFICAR Y
ARMONIZAR ESPACIOS.



TIPO DE LED: IP 54

SOLAPE DE
PUERTA Y FIJO

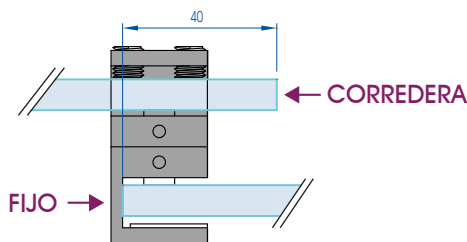

MUESCA
VIDRIO

- Muesca de la
puerta para
cojinetes 4041

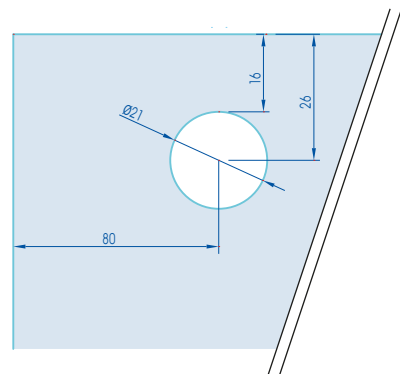

KITS DISPONIBLES



PUERTA MÓVIL
VIDRIO FIJO

NO INCLUIDO:
1831 - 4896 - LED

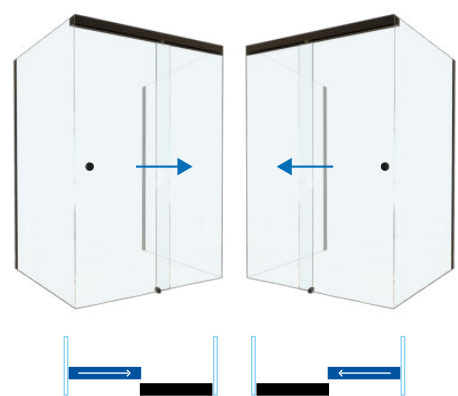
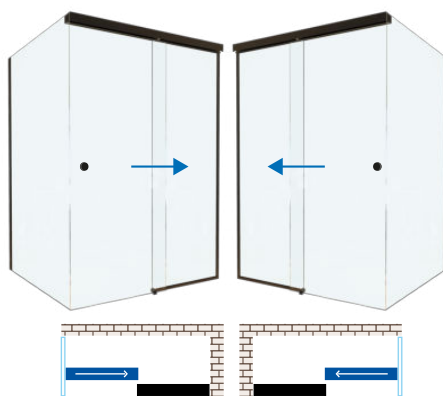
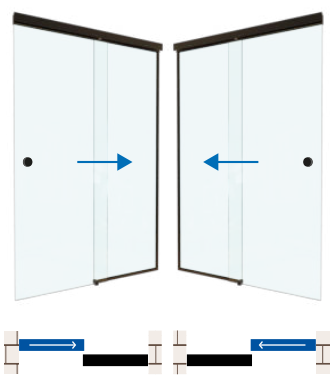

KIT 180° DER/IZQ.

- CON TAPA = 4033
- SIN TAPA = 4037

KIT 90° DER/IZQ.

- CON TAPA = DER.4034 / IZQ.4035
- SIN TAPA = 4036

KIT 90° 2 VIDRIOS FIJOS

CON TAPA (4039):
KIT 4034/B32
+ 1u. 4031/D o Z
SIN TAPA:
KIT 4036/B32
+ 1u. 4030

INSTALACIÓN

CARRIL CON MECANISMO OCULTO

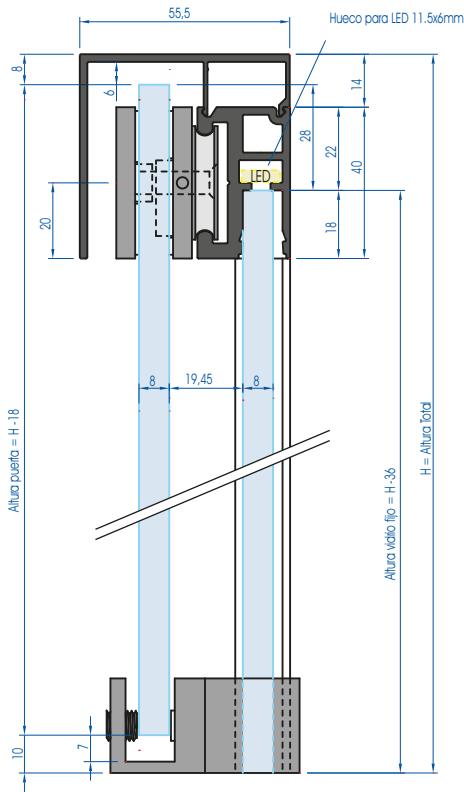

CARRIL CON MECANISMO VISTO

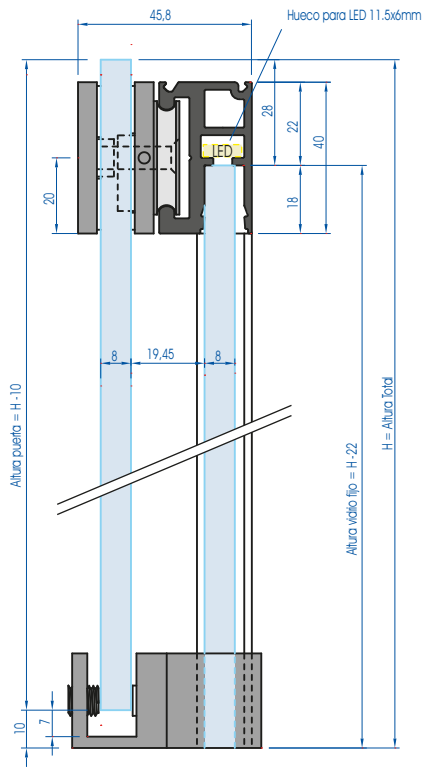

- Iluminación
opcional en el
vidrio fijo

Altura máxima a la
que se puede subir
el vidrio para
regular la puerta=
(±) 6mm

- Vidrios (puerta
corredera y
puerta fija)
- Piezas aluminio
- LED
- Latón

PERFIL "U" EN
EL LATERAL Y
ABAJO

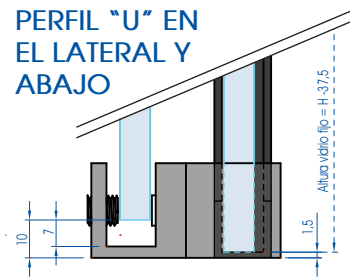

PERFIL "U" EN
EL LATERAL Y
ABAJO

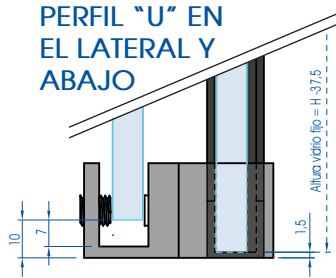

**MUESCA
VIDRIO
(NEMO
PLUS 90°)
TAPA LATERAL**

CON TAPA

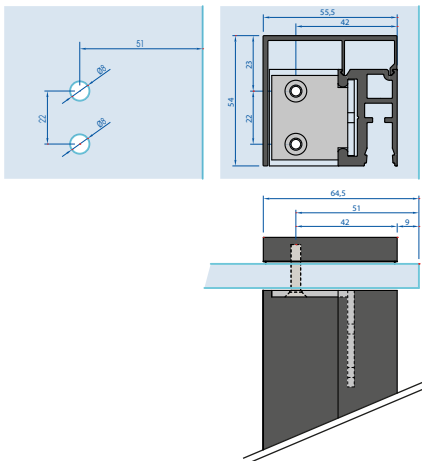

SIN TAPA

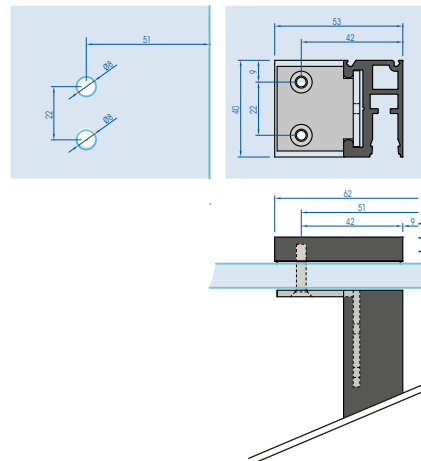



MAMPARA NEMO PLUS

BASADO EN EL SISTEMA NEMO CON ILUMINACIÓN OPCIONAL

KITS

NEMO PLUS / 1 PUERTA + FIJO 180°

ON 32

KIT MAMPARA 1 PUERTA + FIJO 180°
Écran à fermeture douce
Shower screen with soft-closing
Schermo con chiusura rallentata

6-8 mm Max. 40 Kg/Puerta

Sistema basado en el sistema NEMO. Con posibilidad de ILUMINACIÓN opcional. 4 opciones de Kit a elegir:

- > Base (Elementos principales) > "U" (Kit Base + "U")
- > SIN TAPA BASE (Elementos principales sin tapa)
- > SIN TAPA +U (Kit Base sin tapa + "U")

NO INCLUIDOS:
1831/202 - Burlete
4896 - Difusor y LED

Se sirve sin vidrio

CON TAPA	Al Cu	4033/B..	€/u.	○	○	
		BASE				
SIN TAPA	Al Cu	4033/U..	€/u.	○	○	
		+U				
CON TAPA	Al Cu	4037/B..	€/u.	○	○	
		SIN TAPA BASE				
SIN TAPA	Al Cu	4037/U..	€/u.	○	○	
		SIN TAPA +U				

1P. + 1 FIJO 180° - BASE 4033/B componentes:	1U 4038 (2M) 1U 4039 (2M) 2U 4041	2U 4043 2U 4044 1U 4046	1U 4047 2,2M (8mm) 1851/109
1P. + 1 FIJO 180° - "U" 4033/U componentes:	KIT BASE + 1U 4376 o 1657 (3m) 2,2M (8mm) 1851/109		
1P. + 1 FIJO 180° - SIN TAPA BASE 4037/B componentes:	KIT BASE SIN 4039		
1P. + 1 FIJO 180° - SIN TAPA + "U" 4037/U componentes:	KIT BASE SIN 4039 + 1U 4376 o 1657 (3m)	2,2M (6-8mm) 1830/109	

NEMO PLUS / 1 PUERTA + FIJO 90°

ON 32

KIT MAMPARA 1 PUERTA + FIJO 90°
Écran à fermeture douce
Shower screen with soft-closing
Schermo con chiusura rallentata

6-8 mm Max. 40 Kg/Puerta

Sistema basado en el sistema NEMO. Con ILUMINACIÓN opcional. 6 opciones de Kit a elegir:

- > DERECHA Base (Elementos principales). Puerta corredera a la derecha y apertura hacia la izquierda.
- > DERECHA "U" (Kit DER.Base + "U")
- > IZQUIERDA Base (Elementos principales). Puerta corredera a la izquierda y apertura hacia la derecha.
- > IZQUIERDA "U" (Kit DER.Base + "U")
- > SIN TAPA BASE (Elementos principales sin tapa IZQUIERDA Y DERECHA)
- > SIN TAPA +U (Kit Base sin tapa + "U")

NO INCLUIDOS:
1831/202 - Burlete
4896 - Difusor y LED

Se sirve sin vidrio

CON TAPA	Al Cu	4034/B..	€/u.	○	○	
		DER. BASE				
	Al Cu	4034/U..	€/u.	○	○	
SIN TAPA	Al Cu	4035/B..	€/u.	○	○	
		IZQ. BASE				
	Al Cu	4035/U..	€/u.	○	○	
CON TAPA	Al Cu	4036/B..	€/u.	○	○	
		SIN TAPA BASE				
SIN TAPA	Al Cu	4036/U..	€/u.	○	○	
		SIN TAPA +U				

1P.+FIJO 90° - DER. BASE 4034/B componentes:	1U 4038 (2M) 1U 4039 (2M) 2U 4041	2U 4043 1U 4031/D 2U 4044	1U 4046 1U 4047 2,2M (8mm) 1851/109
1P.+FIJO 90° - DER. +U 4034/U componentes:	KIT BASE DERECHA + 1U 4376 o 1657 (6m) 2,2M (8mm) 1851/109		
1P.+FIJO 90° - IZQ. BASE 4035/B componentes:	1U 4038 (2M) 1U 4039 (2M) 2U 4041	2U 4043 1U 4031/Z 2U 4044	1U 4046 1U 4047 2,2M (8mm) 1851/109
1P.+FIJO 90° - IZQ. +U 4035/U componentes:	KIT BASE IZQUIERDA + 1U 4376 o 1657 (6m) 2,2M (8mm) 1851/109		
1P.+FIJO 90° - SIN TAPA BASE 4036/B componentes:	1U 4038 (2M) 2U 4041 2U 4043	1U 4030 2U 4044 1U 4046	1U 4047 2,2M (8mm) 1851/109
1P.+FIJO 90° - SIN TAPA +U 4036/U componentes:	KIT BASE SIN TAPA + 1U 4376 o 1657 (6m) 2,2M (6-8mm) 1830/109		

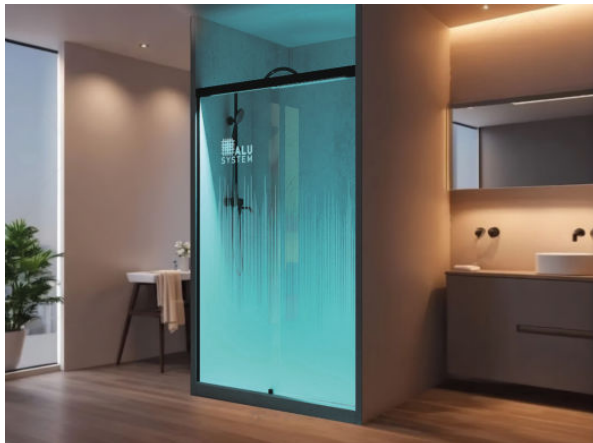

COMPONENTES NEMO PLUS

	CARRIL coulisse haute upper track guida superiore	Al	4038/2..	€/u.
			2M	
		Al	4038/3..	€/u.
			3M	
	TAPA couverture rail cover copercchio	Al	4039/2..	€/u.
			2M	
		Al	4039/3..	€/u.
			3M	
	PERFIL TAPA BOCA CARRIL profil couverture cover profil profilo copri-canale	Pla	4896/209	€/u.

PLÁSTICO PLASTIC PLASTIC PLASTICA	NEGRO NOIR BLACK NERO	PL. BR ALU. BR ALL. BR ALL. LUC
09	0N	02
	○	○
	○	○
	○	○
	○	○
		Resistente al agua y a prueba de polvo
	○	

COMPONENTES NEMO

COJINETE
charlot
roller
cuscinetto
Cu **4041/0..** €/u.

ANCLAJE CARRIL-PARED
fixation mur-coulisse
connexion wall-track
connessione parete-guida
Cu **4043/0..** €/u.

GUÍA SUELO
guidage au sol
floor guide
guida a pavimento
Cu **4046/0..** €/u.

STOP INTERIOR CARRIL
stop charlot
stop roller
stop cuscinetto
Cu **4044/0..** €/u.

	NEGRO NOR BLACK NERO ON	PL. BR ALU. BR ALU. BR ALL. LUC O2
20 Kg/u		
6-8 mm	○	○
21 mm		
6-10 mm	○	○

COMPONENTES
UNIVERSALES

MORSETO VIDRIO-PARED
fixation verre-mur
bracket glass-wall
morsetto vetro-parete
Cu **4105/0..** €/u.

MORSETO VIDRIO-PARED
fixation verre-mur
bracket glass-wall
morsetto vetro-parete
Zn **4108/Z..** €/u.
4108/022 €/u.

"U" ALUMINIO
u aluminium
u alluminio
u alluminio
Al **1659/10N** €/m
5m / 15x15x15x1,5
Al **1657/10N** €/m
6m / 12x12x12x1,5

	NEGRO NOR BLACK NERO ON	INOX BR INOX POLI P.S.S. INOX LUC	CR. BRILLO CR. POLI BR. CR. CR. LUC. 32
8-12 mm			○
16 mm	○		
8-12 mm			○
16 mm	○		
5/6 M			
max. 10 mm	○		
max. 8 mm	○		
3 M			

COMPONENTES NEMO PLUS
(PARA 90°)

**CONEXIÓN 90° CARRIL - VIDRIO FIJO
PARA NEMO PLUS 90° SIN TAPA (4039)**
Fixation verre-coulisse (sans 4039)
Connexion glass-track (without 4039)
Connessione vetro-guida (senza 4039)
Pla **4030/0..** €/u.

**CONEXIÓN 90°
CARRIL - VIDRIO FIJO PARA NEMO PLUS
90° CON TAPA (4039) DERECHA**
Fixation verre-coulisse (avec 4039) DROITE
Connexion glass-track (with 4039) RIGHT
Connessione vetro-guida (con 4039)
DESTRA
Pla **4031/D..** €/u.

**CONEXIÓN 90° CARRIL - VIDRIO FIJO
PARA NEMO PLUS 90° CON TAPA (4039)
IZQUIERDA**
Fixation verre-coulisse (avec 4039)
GAUCHE
Connexion glass-track (with 4039) LEFT
Connessione vetro-guida (con 4039)
SINISTRA
Pla **4031/Z..** €/u.

	NEGRO NOR BLACK NERO ON	CR. BRILLO CR. POLI BR. CR. CR. LUC. 32
8-10 mm	○	○
8 mm		
8-10 mm	○	○
8 mm		
8-10 mm	○	○
8 mm		

"U" INOX PULIDO
u inox poli
u polished stainless steel
u inox lucido
lx **4375/122** €/m
15x15x15x1
lx **4376/122** €/m
15x12x15x1
lx **4377/122** €/m
25x15x25x1

TAPAJUNTA ADHESIVO 2.5 M
profil étanchéité adhesive 2,5m
adhesive seal 2,5 m
giunta adesiva 2,5 m
Pla **1811/109** €/m

PERFIL LATERAL CORREDERA
prof. étanchéité coulissant
sliding door seal
giunta porta scorrevole
Pvc **1851/109** €/m

PERFIL MAMPARAS
prof. étanchéité
seal
giunta
Pvc **1830/1..** €/m

max. 12 mm	○
max. 8 mm	○
max. 12 mm	○
PLÁSTICO PLASTIC PLASTIC PLASTICA 09	
2,5 M	
8-10 mm	
8 mm	2,2 M
6-8 mm	2,2 M
2M	

COMPONENTES
UNIVERSALES

POMO
poignée
knob
pomo
Cu **4047/0..** €/u.

TIRADOR 20 CM
Poignée 20 cm
Handle 20 cm
Maniglia 20 cm
Al **4114/0..** €/u.

TIRADOR 40 CM
Poignée 40 cm
Handle 40 cm
Maniglia 40 cm
Al **5129/0..** €/u.

MANILLA DOBLE
poignée double
boule door pull
maniglia doppia
Al **4129/A32** €/u.
Al **4129/A0N** €/u.

MANILLA DOBLE
poignée double
boule door pull
maniglia doppia
Zn **4139/Z..** €/u.

	NEGRO NOR BLACK NERO ON	PL. BR ALU. BR ALU. BR ALL. LUC O2	CR. BRILLO CR. POLI BR. CR. CR. LUC. 32
6-8 mm	○	○	○
10 mm			
20 cm	○	○	○
40 cm	○	○	○
6-10 mm	○	○	○
2 x Ø8 mm			
cc=220mm			
6-10 mm	○	○	○
2 x Ø8 mm			
cc=191mm			
226x34 mm	○	○	○

COMPONENTES ILUMINACIÓN

DIFUSOR PLÁSTICO MATE
diffuseur en plastique mat
mat plastic diffusor
diffusore plastico opaco
Pla **4896/209** €/u.

**LED LUZ BLANCA
4000K 24V 14.2W/M**
lumière blanche LED
LED white light
luce LED bianca
Pla **4007/159** €/u.

TRANSFORMADOR 24V 36W
transformateur
transformer
transformatore
Pla **4008/009** €/u.

PERFIL CUÑA PARA VIDRIO FIJO 8MM
profil de coin pour verre fixe 8mm
wedge profile for fixed glass 8mm
profilo a cuneo per vetro fisso 8mm
Pvc **1844/109** €/m

2 M	Resistente al agua y a prueba de polvo	○
1,5 M	Módulo LED 10cm	IP 54
Resistente al agua y a prueba de polvo		○
1,5 M	Módulo LED 10cm	IP 54
Resistente al agua y a prueba de polvo		○
8 mm	1 M	○
Resistente al agua y a prueba de polvo		○

MAMPARA NEMO

VIDRIO RECOMENDADO 8MM

KITS

NEMO / 1 PUERTA + FIJO 90°

ON 32 T2



KIT MAMPARA 1 PUERTA + FIJO 90°

Ecran à fermeture douce
Shower screen with soft-closing
Schermo con chiusura rallentata

6-8 mm Max. 40 Kg/Puerta
Sistema sencillo versátil y fácil montaje.
3 opciones de Kit a elegir:
> Base (Elementos principales)
> "U" (Kit Base + "U")
> "M" (Kit Base + 4108)

Al Cu **4026/B..** €/u.
BASE
Al Cu **4026/U..** €/u.
+U
Al Cu **4026/M..** €/u.
+4108

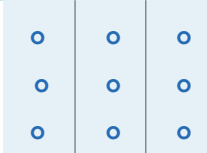

NO INCLUIDOS:
1831/202 - Burlete

Se sirve sin vidrio

4026/B - 1 FIJO 90° - BASE

componentes:

2M 4040
2U 4041
2U 4042

2U 4043
1U 4027
2U 4044

1U 4046
1U 4047
2,2M (8mm) 1851/109

4026/U - 1 FIJO 90° - "U"

componentes:

2M 4040
2U 4041
2U 4042
2U 4043

1U 4027
2U 4044
1U 4046
1U 4047

6M 4376 o 1657
2,2M (8mm) 1851/109
2,2M (6-8mm) 1830/109

4026/M - 1 FIJO 90° - "M"

componentes:

2M 4040
2U 4041
2U 4042
2U 4043

1U 4027
2U 4044
1U 4046
1U 4047

4U 4108
2,2M (8mm) 1851/109
2,2M (6-8mm) 1830/109

NEMO / 2 PUERTAS ENFRENTADAS 90°

ON 32 T2



KIT MAMPARA 2 PUERTAS 90°

Ecran à fermeture douce
Shower screen with soft-closing
Schermo con chiusura rallentata

6-8 mm Max. 40 Kg/Puerta
3 opciones de Kit a elegir:
> Base (Elementos principales)
> "U" (Kit Base + "U")
> "M" (Kit Base + 4108)

Al Cu **4048/B..** €/u.
BASE
Al Cu **4048/U..** €/u.
+U
Al Cu **4048/M..** €/u.
+4108



NO INCLUIDOS:
1831/202 - Burlete

Se sirve sin vidrio

4048/B - 2 PUERTAS 90° - BASE

componentes:

2M 4040
4U 4041
4U 4042

2U 4043
1U 4045
4U 4044

2U 4046
2U 4047
4,4M (8mm) 1851/109

4048/U - 2 PUERTAS 90° - "U"

componentes:

2M 4040
4U 4041
4U 4042
2U 4043

1U 4045
4U 4044
2U 4046
2U 4047

6M 4376 o 1657
4,4M (8mm) 1851/109
2,2M (6-8mm) 1828/109
2,2M (6-8mm) 1829/109

4048/M - 2 PUERTAS 90° - "M"

componentes:

2M 4040
4U 4041
4U 4042
2U 4043

1U 4045
4U 4044
2U 4046
2U 4047

4U 4108
4,4M (8mm) 1851/109
2,2M (6-8mm) 1828/109
2,2M (6-8mm) 1829/109

NEMO / 1 PUERTA 180°

ON 32 T2



KIT MAMPARA 1 PUERTA 180°

Ecran à fermeture douce
Shower screen with soft-closing
Schermo con chiusura rallentata

6-8 mm Max. 40 Kg/Puerta
3 opciones de Kit a elegir:
> Base (Elementos principales)
> "U" (Kit Base + "U")
> "M" (Kit Base + 4108)

Al Cu **4049/B..** €/u.
BASE
Al Cu **4049/U..** €/u.
+U
Al Cu **4049/M..** €/u.
+4108



NO INCLUIDOS:
1831/202 - Burlete

Se sirve sin vidrio

4049/B - 1 PUERTA 180° - BASE

componentes:

2M 4040
2U 4041
2U 4042

2U 4043
2U 4044
1U 4046

1U 4047
2,2M (8mm) 1851/109

4049/U - 1 PUERTA 180° - "U"

componentes:

2M 4040
2U 4041
2U 4042
2U 4043

1U 4027
2U 4044
1U 4046
1U 4047

3M 4376 o 1657
2,2M (8mm) 1851/109
2,2M (6-8mm) 1830/109

4049/M - 1 PUERTA 180° - "M"

componentes:

2M 4040
2U 4041
2U 4042
2U 4043

2U 4044
1U 4046
1U 4047
2U 4108

2,2M (8mm) 1851/109
2,2M (6-8mm) 1830/109



Nemo "Cuadrado"
Se añaden tapas cuadradas (4041/T32) que se enganchan a los cojinetes (4041 y 4042)

COMPONENTES NEMO



CARRIL
coulisse haute
upper track
guida superiore

Al **4040/2..** €/u.
Al **4040/3..** €/u.



COJINETE
chariot
roller
cuscinetto

Cu **4041/0..** €/u.



ANCLAJE VID.FIJO-CARRIL
fixation verre-coulisse
connexion glass-track
connessione vetro-guida

Cu **4042/0..** €/u.



TAPA CUADRADA 4041-4042
carré 4041/4042
square cover 4041/4042
copertina quadrata 4041/4042

Abs ***4041/T32** €/u.



ANCLAJE CARRIL-PARED
fixation mur-coulisse
connexion wall-track
connessione parete-guida

Cu **4043/0..** €/u.



ANCLAJE CARRIL-PARED
Fixation mur-coulisse
connexion wall-track
connessione parete-guida

Cu **4050/0..** €/u.



GUÍA SUELO
guidage au sol
floor guide
guida a pavimento

Cu **4046/0..** €/u.



STOP INTERIOR CARRIL
stop chariot
stop roller
stop cuscinetto

Cu **4044/0..** €/u.



CONEXIÓN 90° CARRIL-VID.FIJO
fixation verre-coulisse
connexion glass-track
connessione vetro-guida

Cu **4027/0..** €/u.



CONEXIÓN 90° CARRIL
fixation coulisse 90°
tracks connexion 90°
connessione guide 90°

Cu **4045/0..** €/u.



REMATE FINAL CARRIL
bouchon coulisse
end-cap track
capri testa guida superiore

Cu ***4028/032** €/u.

NEGRO NOIR BLACK NERO	PL. BR ALU. BR ALL. LUC	CR. BRILLO CH. POLI BR. CHR CR. LUC.
ON	02	32

2-3 M	8 mm	Ø10 mm
40x12		
○	○	
○	○	

20 Kg/u	6-8 mm	Ø 21 mm
○		○

6-8 mm	Ø 14-15 mm
○	○

4041	No se venden por separado
4042	
○	○

○	○
○	○

○	○
○	○

○	6-10 mm	○
○		○

○	○
○	○

○	6-8 mm	Ø 8 mm	○
○			○

○	○
○	○

○	*	○
---	---	---



"U" ALUMINIO
u aluminium
u aluminium
u alluminio

Al **1659/10N** €/m
5m / 15x15x15x1,5
Al **1657/10N** €/m
6m / 12x12x12x1,5



"U" INOX PULIDO
u inox poli
u polished stainless steel
u inox lucido

lx **4375/122** €/m
15x15x15x1
lx **4376/122** €/m
15x12x15x1
lx **4377/122** €/m
25x15x25x1



PERFIL CON IMÁN 90°/180°
profil étancheité magnetique 90°/180°
magnetic seal 90°/180°
giunta magnetica 90°/180°

Pvc ***1828/109** €/m
IMAN DERECHA
Pvc ***1829/109** €/m
IMAN IZQUIERDA

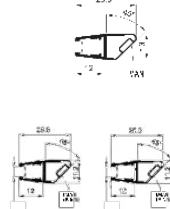

SET DER.+IZQ. - TAPAJUNTA CON IMÁN
set droite+gauche -
prof. étancheité magnetique
set right-left -magnetic seal
set destra-sinistra -giunta magnetica

Pvc **1868/2..** 6mm €/u.
Pvc **1866/2..** 8mm €/u.

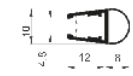

PERFIL MAMPARAS
prof. étancheité
seal
giunta

Pvc **1830/109** €/m



PERFIL LATERAL CORREDERA
prof. étancheité coulissent
sliding door seal
giunta porta scorrevole

Pvc **1851/109** €/m

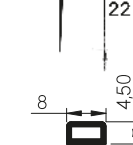

TAPAJUNTA ADHESIVO 2.5 M
profil étancheité adhesive 2,5m
adhesive seal 2,5 m
giunta adesiva 2,5 m

Pca **1811/109** €/m



PERFIL BURLETE DE ALUMINIO
profile levre-uo
lip-up profile
profilo verticacque

Al **1831/202** €/u.
Al **1831/20N** €/u.

NEGRO NOIR BLACK NERO	INOX INOX P.S.S INOX	BR POLI LUC	PLÁSTICO PLASTILE PLASTIC PLASTICA
ON	22	09	

5/6 M		
○	max. 10 mm	
○	max. 8 mm	

3 M		
-----	--	--

max. 12 mm	○
max. 8 mm	○
max. 12 mm	○

6-8 mm	2,2 M
--------	-------

○	○
○	○

6-8 mm	2,2 M
--------	-------

○	○
○	○

6-8 mm	2,2 M
--------	-------

○	○
8 mm	2,2 M

2,5 M	8-10 mm
-------	---------

○	
---	--

CR. BRILLO CH. POLI BR. CHR CR. LUC.	NEGRO NOIR BLACK NERO
32	ON

○	2M
○	

COMPONENTES
UNIVERSALES



POMO
poignée
knob
pomo

Cu **4047/0..** €/u.

6-8 mm	Ø 10 mm
--------	---------



MORSETO VIDRIO-PARED
fixation verre-mur
bracket glass-wall
morsetto vetro-parete

Cu **4105/0..** €/u.

8-12 mm	Ø 16 mm
---------	---------



MORSETO VIDRIO-PARED
fixation verre-mur
bracket glass-wall
morsetto vetro-parete

Zn **4108/Z..** €/u.
4108/022 €/u.

8-12 mm	Ø 16 mm
---------	---------



MAMPARA VERONA CUADRO

VIDRIO RECOMENDADO 8MM

KITS

KITS - VERONA CUADRO 90°

ON O2



KIT MAMPARA VERONA CUADRO COJINETES CUADRADOS 90° CON FIJO

kit écran avec roulements carrés. 90° avec fixe
Screen kit with square bearings. 90° with fixed
kit schermo con cuscinetti quadrati. 90° con fisso



Al Pr 5861/0.. E/Al

Se sirve sin vidrio
90° CON FIJO
componentes:

- (X2) 5855/2..
- (X1) 5852/0..
- (X1) 5851/0..
- (X1) 5850/2..
- (X1) 5129/0..
- (X1) 5858/0..
- (X1) 5859/2..
- (X1) 5853/0..

KITS - VERONA CUADRO 180° SIN PARED

ON O2



KIT MAMPARA VERONA CUADRO COJINETES CUADRADOS 180° SIN PARED

kit écran avec roulements carrés. 180° sans mur
Screen kit with square bearings. 180° without wall
kit schermo con cuscinetti quadrati. 180° senza parete



Al Pr 5862/0.. E/Al

Se sirve sin vidrio
180° SIN PARED
componentes:

- (X1) 5855/2..
- (X1) 5852/0..
- (X1) 5851/0..
- (X1) 5850/2..
- (X1) 5129/0..
- (X1) 5858/0..

KITS - VERONA CUADRO 180° A PARED

ON O2



KIT MAMPARA VERONA CUADRO COJINETES CUADRADOS 180° A PARED

kit écran avec roulements carrés. 180° au mur
Screen kit with square bearings. 180° to wall
kit schermo con cuscinetti quadrati. 180° alla parete



Al Pr 5860/0.. E/Al

Se sirve sin vidrio
180° A PARED
componentes:

- (X1) 5855/2..
- (X1) 5852/0..
- (X1) 5857/0..
- (X1) 5851/0..
- (X1) 5850/2..
- (X1) 5129/0..
- (X1) 5858/0..

VERONA CUADRO 180°

VERONA CUADRO 90°

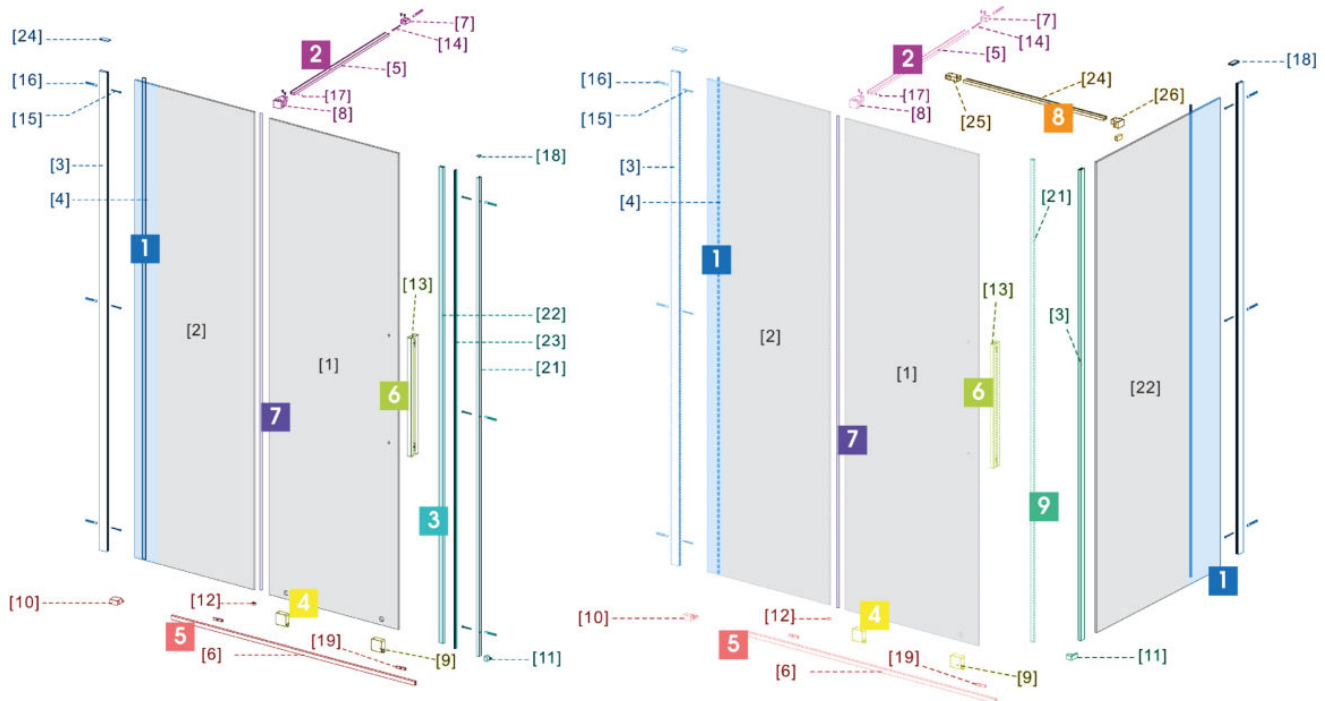

COMPONENTES VERONA CUADRO

	NEGRO NOR. BLACK NERO	PL. BR. ALU. BR. ALL. LUC	OR. BRILLO OF. POLI BR. CHR OR. LUC.
	0N	02	32
1	○	○	
2	○	○	
3	○	○	
4	○		○
5	○	○	
6	○	○	
7	○		○
8	○	○	
9	○	○	

- 1. KIT GUÍA LATERAL FIJO PARED-VIDRIO**
kit de guidage lateral fixe mur-verre
fixed side guide kit wall-glass
kit guide laterali fisse parete-vetro
5855/2..
- 2. KIT BARRA DE REFUERZO VERTICAL**
kit de barres de renfort verticales
vertical rebar kit
kit barre di rinforzo verticali
5852/0..
- 3. KIT LATERAL PMÓVIL VIDRIO-PARED**
kit lateral pour porte mobile verre-mur
Side kit for mobile door glass-wall
kit laterale porta mobile vetro-parete
5857/0..
- 4. COJINETES CUADRADOS**
roulements carrés
square bearings
cuscinetti quadrati
5851/0..
- 5. KIT GUÍA INFERIOR**
kit de guidage inférieur
lower guide kit
kit guida inferiore
5850/2..
- 6. TIRADOR 40CM**
tirezor 40 cm
handle 40 cm
tiratore 40 cm
Al 5129/0..
- TIRADOR 20 CM**
tirezor 20 cm
handle 20 cm
tiratore 20 cm
Al 4114/0..
- 7. TAPAJUNTAS ENTRE PUERTAS**
alignant entre les portes
flashing between doors
lampeggiate tra le porte
5858/2..
- 8. KIT BARRA DE REFUERZO HORIZONTAL**
kit de barres de renfort horizontales
horizontal reinforcement bar kit
kit barre di rinforzo orizzontali
5853/0..
- 9. KIT LATERAL PMÓVIL VIDRIO-VIDRIO**
kit lateral pour porte mobile verre-mur
Side kit for mobile door glass-wall
kit laterale porta mobile vetro-parete
5859/2..

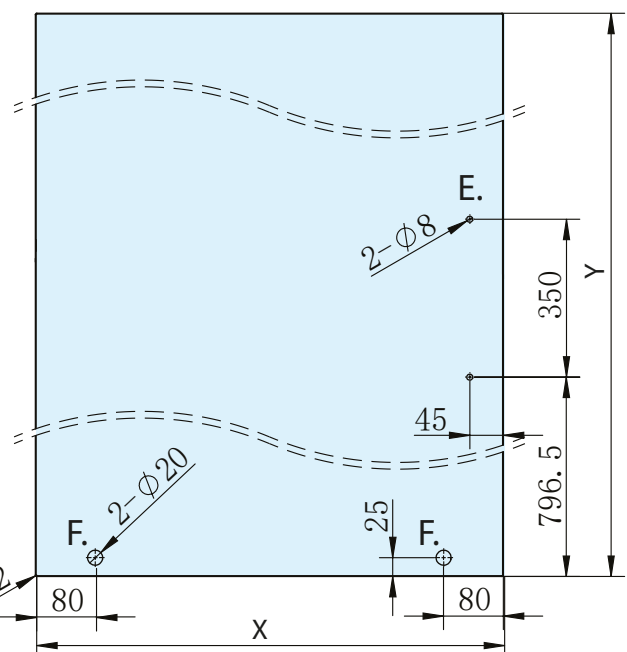
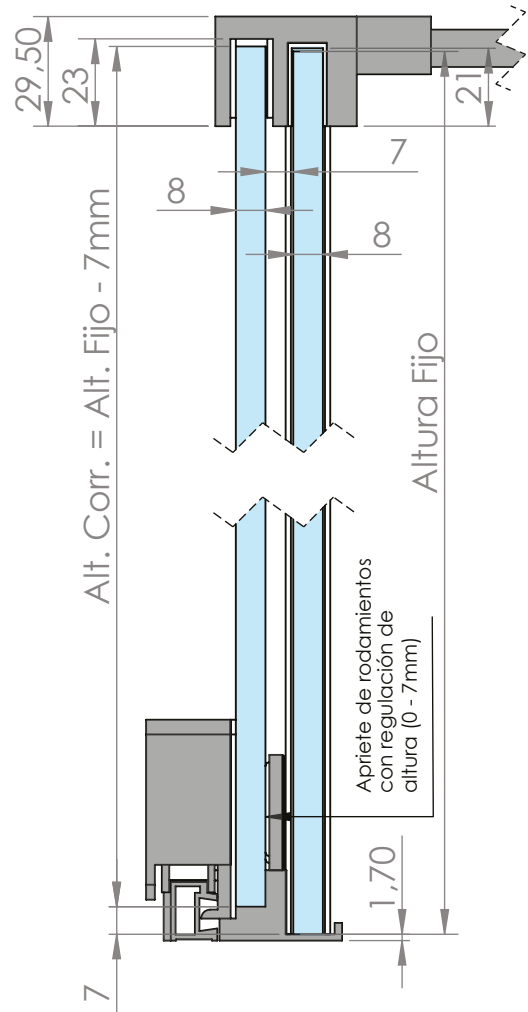

E. Tirador
F. Ruedas

Ancho corredera =
Ancho fijo + 75mm
Todos nos fijos tienen la
misma medida de altura

MAMPARA VERONA

VIDRIO RECOMENDADO 8MM

KITS

VERONA / 1 PUERTA + FIJO 180°

02



KIT MAMPARA VERONA COJINETES CIRCULARES 1 PUERTA + FIJO 180°
 kit écran avec roulements carrés. 90° avec fixe
 Screen kit with square bearings. 90° with fixed
 kit schermo con cuscinetti quadrati. 90° con fisso

8 mm Max. 40 Kg/Puerta



Cojinetes redondos

... 5950/002

€/U.



1P. + FIJO 180°
componentes:

1U 5955
2U 5956
1U 5957

1SET 5959
1U 5960
1U 5961

1U 5962
1SET 5963

VERONA / 1 PUERTA + FIJO 90°

02



KIT MAMPARA VERONA COJINETES CIRCULARES 1 PUERTA + FIJO 90° CON FIJO
 kit écran avec roulements carrés. 90° avec fixe
 Screen kit with square bearings. 90° with fixed
 kit schermo con cuscinetti quadrati. 90° con fisso

8 mm Max. 40 Kg/Puerta



Cojinetes redondos

... 5951/002

€/U.



1P. + FIJO 90°
componentes:

1U 5955
2U 5956
1U 5958

1SET 5965
1U 5960
1U 5961

1SET 5964

VERONA
 Mampara ducha
 rodamiento a suelo
 Aluminio anodizado brillo
 Peso max: 40 kg/puerta
 Vidrio: 8 mm

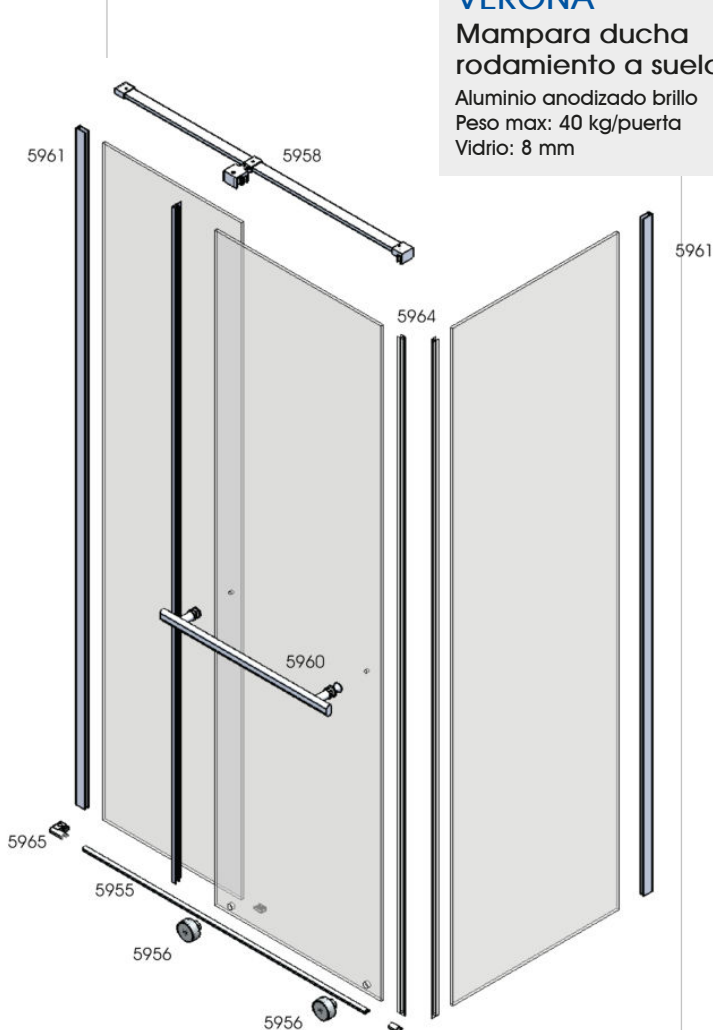
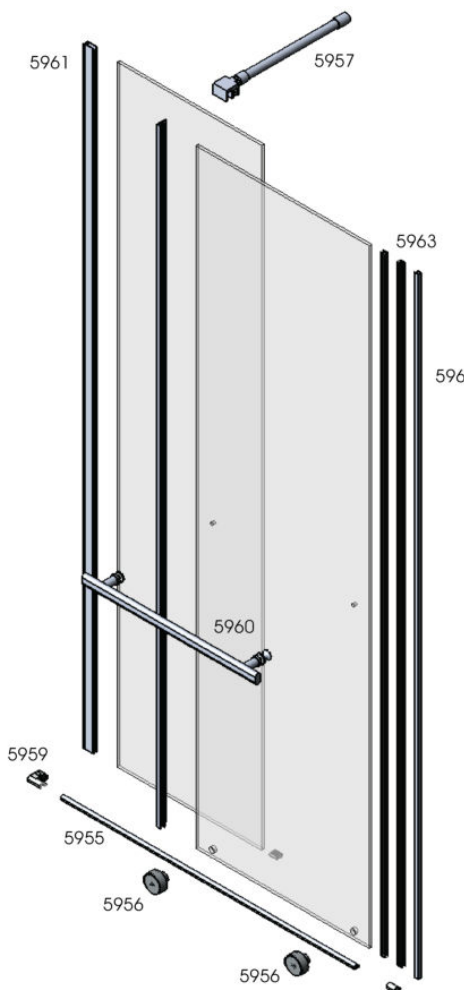

COMPONENTES VERONA

CR. BRILLO	PL. BR	PLÁSTICO
CHR. POLI	ALU. BR	PLASTIC
CR. LUC.	ALU. BR	PLASTIC
	ALL. LUC	PLASTICA
32	02	09

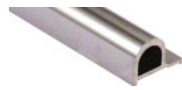

CARRIL	Al	2 m	€/u
--------	----	-----	-----

COULISSE HAUTE
UPPER TRACK
GUIDA SUPERIORE
5955/202



COJINETE	Cu	20 kg/u	8 mm	€/u
CHARLOT			∅ 15 mm	

ROLLER
CUSCINETTO
5956/032



GUÍA SUPERIOR + BARRA	Zn	inox s.s.	8 mm	€/u
-----------------------	----	-----------	------	-----

REFUERZO 90° VIDRIO FIJO
GUIDAGE SUPERIEUR +
BARRA RENFORT 90°
UPPER GUIDE + FIXING
BAR WALL-GLASS 90°
GUIDA SUPERIORE + BARRA
RINFORZO 90° VETRO FISSO
5957/032



GUÍA SUPERIOR + BARRA	Zn	inox s.s.	8 mm	1,2 m	€/u
-----------------------	----	-----------	------	-------	-----

REFUERZO 180° VIDRIO FIJO
GUIDAGE SUPERIEUR +
BARRA RENFORT 180°
UPPER GUIDE + FIXING
BAR WALL-GLASS 180°
GUIDA SUPERIORE + BARRA
RINFORZO 180° VETRO FISSO
5958/032



SET STOP + FIJACIÓN INFERIOR	ABS	8 mm	€/u
------------------------------	-----	------	-----

VIDRIO FIJO+REIMATE FINAL CARRIL
SET STOP + FIXATION INFERIEUR
VERRE FIXE + FINITION COULISSE
SET STOPS+ FIXING GLASS BOTTOM
+ TRACK EMBELLICER
SET STOPS + FISSAGGIO INFERIORE
VETRO FISSO + COPRITESTA

5959

5959/032 x kit 5950
5965/032 x kit 5951



5965



TIRADOR TOALLERO	Zn	inox s.s.	6-10 mm	€/u
------------------	----	-----------	---------	-----

BARRA RECTANGULAR
MANILLA + TOALLERO
POIGNÉE + SERVIETTE
HANDLE WITH TOWEL BAR
MANIGLIONE CON PORTA
ASCIUGAMANO
5960/032

440

540



POMO	Cu	6-8 mm	∅ 16 mm	€/u
------	----	--------	---------	-----

POIGNÉE
KNOB
POMO
4047/032



"U" ALUMINIO PARED	Al	1,95 m	8 mm	€/u
--------------------	----	--------	------	-----

"U" ALUMINIUM MUR
"U" ALUMINUM WALL
"U" DI ALLUMINIO PARETE
Vidrio de 8 mm
5961/202



PERFALUM. X TAPAJUNTAS	Al	1,95 m	8 mm	€/u
------------------------	----	--------	------	-----

ALUM. PROF. ÉTANCHEITÉ
ALUM. PROF. SEAL
PROF. ALLUMINIO, GIUNTA
5962/202



KIT TAPAJUNTAS	pvc	2 m	8 mm	€/u
----------------	-----	-----	------	-----

PROF. ÉTANCHEITÉ
SEAL
GIUNTA
5963/209 x kit 5950



KIT TAPAJUNTAS	pvc	2 m	8 mm	€/u
----------------	-----	-----	------	-----

PROF. ÉTANCHEITÉ
SEAL
GIUNTA
5964/209 x kit 5951

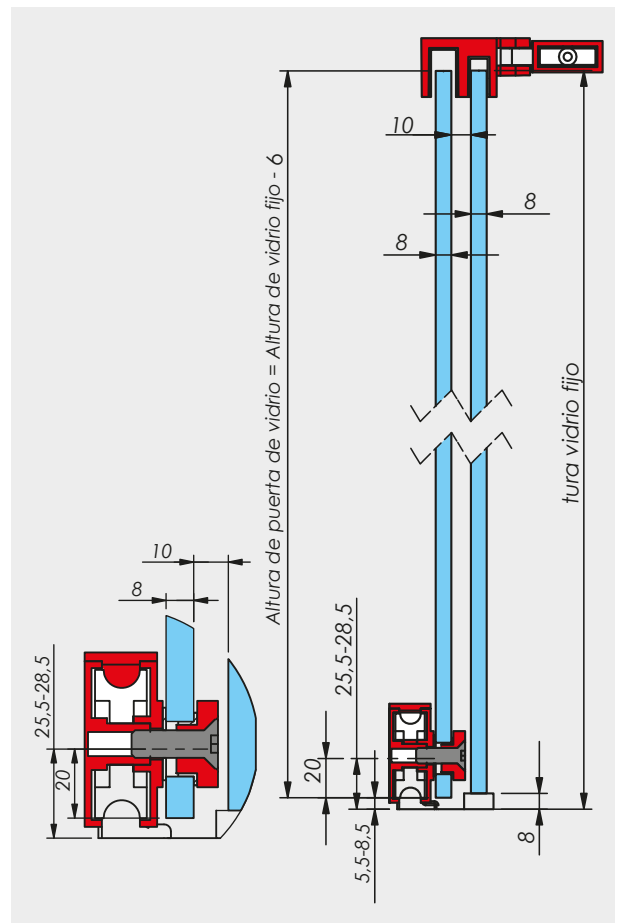

COMPONENTES
UNIVERSALES

NEGRO	PL. BR
NOR	ALU. BR
BLACK	ALU. BR
NERO	ALL. LUC
0N	02

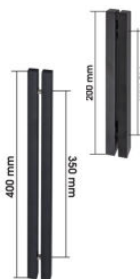

TIRADOR 20 CM
tiseur 20 cm
handle 20 cm
tiratore 20 cm
Al 4114/0..

TIRADOR 40 CM
tiseur 40 cm
handle 40 cm
tiratore 40 cm
Al 5129/0..

6-8 mm	2 x ∅8mm
20 cm	CC=145mm

6-8 mm	2 x ∅8mm
40 cm	CC=350mm



MAMPARA OSLO

CR.BILO
C-R.FOI
BR.CHR
CR.LUC.
32

KITS

1 PUERTA
180°



KIT 180° BASE

Kit compuesto por:

- 4920/202 2 m.
- 4921/022 2 u.
- 4922/022 2 u.
- 4924/009 2 u.
- 3488/022 1 u.
- 4047/032 1 u.
- 1856/109 1 m. (8-10 mm)
- 1852/209 1 u. (8-10 mm)

4928/B32

€/U

KIT 180° BASE

+ U INOX

- 4376/122 3 m (8 mm)
- 1833/109 2,2 m (8-10mm)

4928/U32

€/U

KIT 90° BASE

+ 4105

- 4105/032 2 u.
- 1833/109 2,2 m (8-10mm)

4928/M32

€/U

NO incluidos:
Burlete
1831/202

1 PUERTA
+ FIJO 90°



KIT 1 puerta + fijo 90° BASE

Kit compuesto por:

- 4920/202 2 m.
- 4921/022 2 u.
- 4922/022 2 u.
- 4926/032 1 u.
- 4924/009 2 u.
- 3488/022 1 u.
- 4047/032 1 u.
- 1856/109 1 m.
- 1852/209 1 u. (8-10 mm)

4929/B32

€/U

KIT 90° BASE

+ U INOX

- 4376/122 6 m (8 mm)
- 1833/109 2,2 m

4929/U32

€/U

KIT 90° BASE

+ 4105

- 4105/032 4 u.
- 1833/109 2,2 m

4929/M32

€/U

NO incluidos:
Burlete
1831/202

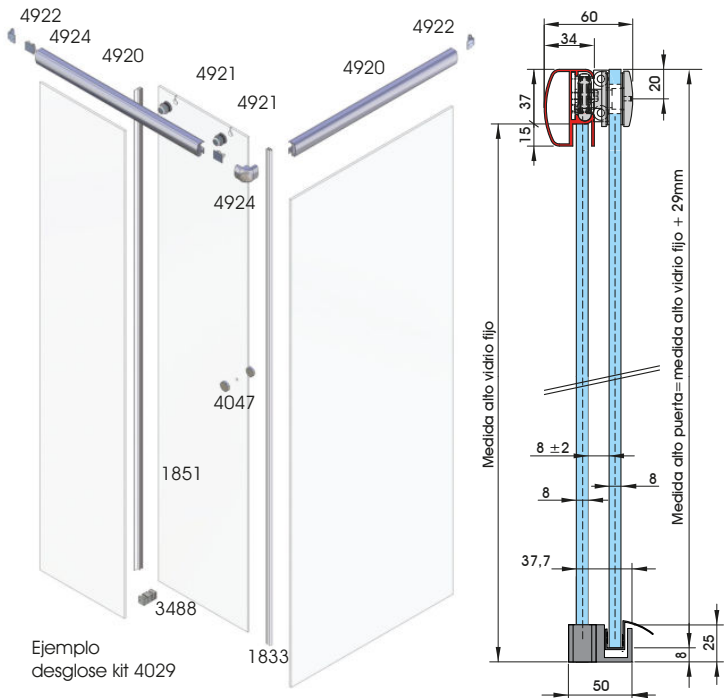

- peso max: 40 kg/puerta
- vidrio: 8-10 mm
- poids max: 40 kg/porte
- verre: 8-10 mm
- max weight: 40 kg/door
- glass: 8-10 mm
- peso max: 40 kg/porta
- vetro: 8-10 mm

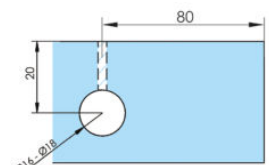

Muesca en OSLO de vidrio para cojinete 4921/022.

COMPONENTES OSLO



CARRIL
COULISSE HAUTE
UPPER TRACK
GUIDA SUPERIORE
4920/202
*4920/252

Próximamente nuevo diseño



COJINETE
CHARLOT
ROLLER
CUSCINETTO
4921/022



ANCLAJE CARRIL-PARED
FIXATION MUR-COULISSE
CONNEXION WALL-TRACK
CONNESSIONE PARETE-GUIDA
4922/022



STOP INTERIOR CARRIL
STOP CHARLOT
STOP ROLLER
STOP CUSCINETTO
4924/009



GUÍA SUELO VIDRIO
GUIDAGE AU SOL VERRE
FLOOR GUIDE GLASS
GUIDA A PAVIMENTO VETRO
3488/022

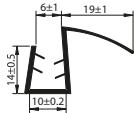

PERFIL INFERIOR
PROF. ETANCHEITE
SEAL
GIUNTA
1856/109
1856/10N

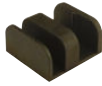

GUÍA SUELO
GUIDAGE AU SOL
FLOOR GUIDE
GUIDA A PAVIMENTO
*4333/009



"U" INOX PULIDO
U INOX POLI
U POL. STAINLESS STEEL
U INOX LUCIDO
15x15x15x1 mm
4375/122
15x12x15x1 mm
4376/122
25x15x25x1 mm
4377/122

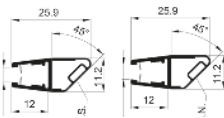

CONJUNTO DE TAPAJUNTAS
DER./IZQ. CON IMÁN
PROF. ETANCHEITE MAGNETIC
MAGNETIC SEAL
GIUNTA MAGNETICA
SET DERECHA + IZQUIERDA
SET DROITE + GAUCHE
SET RIGHT+ LEFT
SET DESTRA + SINISTRA
1866/20. 8 mm
1867/20. 10 mm

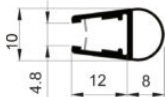

PERFIL MAMPARAS
PROF. ETANCHEITE
SEAL
GIUNTA
1833/109

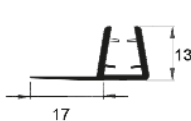

PERFIL LATERAL CORREDERA
PROF. ETANCHEITE COULISSENT
SLIDING DOOR SEAL
GIUNTA PORTA SCORREVOLE
1852/209 8 mm
1853/209 10 mm

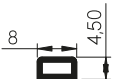

TAPAJUNTA ADHESIVO 2,5 M
PROFIL ETANCHEITE ADHESIVE 2,5 M
ADHESIVE SEAL 2,5 M
GIUNTA ADESIVA 2,5 M
€/M Pla 1811/109

PL. BR ALU. BR ALU. BR ALL. LUC	INOX BR INOX POLI P.S.S. INOX LUC	PLÁSTICO PLASTIQUE PLASTIC PLASTICA
02	22	09

Al	2 m	34x52	€/u
8-10 mm			

○

*○

Cu	20 kg/u	8-10 mm	€/u
∅ 15 mm			

○

inox s.s.	€/u
-----------	-----

○

inox s.s.	€/u
-----------	-----

○

inox s.s.	10 mm	€/u
∅ 1856		

○

pvc	8-10 mm	€/m
∅ 3488		

○

pla	8-12 mm	€/u
-----	---------	-----

*○

inox s.s.	3 m	€/m
-----------	-----	-----

max. 12 mm	
------------	--

max. 8 mm	
-----------	--

max. 12 mm	
------------	--

pvc	2,2 m	8-10 mm	€/u
-----	-------	---------	-----

NEGRO
NOR
BLACK
NERO
ON

○

○

pvc	2,2 m	8-10 mm	€/m
-----	-------	---------	-----

○

pvc	2,2 m	8-10 mm	€/u
-----	-------	---------	-----

○

2,5 M	
-------	--

○

8-10 mm	
---------	--

○

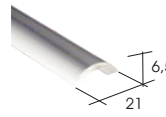

PERFIL BURLETE
PROFILE LEVRE-UO
LIP-UP PROFILE
PROFLO VERTIACQUE
1831/20.



MORSETO VIDRIO-PARED
FIXATION VERRE-MUR
BRACKET GLASS-WALL
MORSETTO VETRO-PARETE
4105/032



UNERO
POIGNEE
KNOB
POMO
*4917/032



POMO
POIGNEE
KNOB
POMO
4047/032



CONEXIÓN 90° CARRIL
FIXATION COULISSE 90°
TRACKS CONNEXION 90°
CONNESSIONE GUIDE 90°
*4926/032



LLAVE REGULABLE x TORNILLO
OUTIL RÉGLABLE x VIS
ADJUSTABLE TOOL SCREWS
UTENSILE REGOLABILE x VITI
4921/010

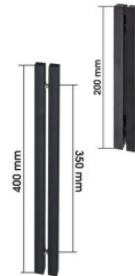

TIRADOR 20 CM
TIREUR 20 cm
handle 20 cm
tiratore 20 cm
Al 4114/0..

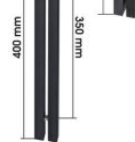

TIRADOR 40 CM
TIREUR 40 cm
handle 40 cm
tiratore 40 cm
Al 5129/0..

NEGRO NOR BLACK NERO	CR. BRILLO C.R. POLI BR. CHR CR. LUC.
ON	32

Al	2 m	€/u
21x6,5		

○

Cu	8-12 mm	€/u
∅ 16 mm		

○

Al	8-10 mm	€/u
∅ 46 mm		

*○

Cu	6-8 mm	€/u
∅ 16 mm		

○

plas	€/u
------	-----

○

*○

ZINCADO PL ZNK ZINK PL ZINCATO	34
---	----

○

ALU. BR ALU. BR ALL. LUC	02
--------------------------------	----

6-8 mm	2 x ∅8mm
20 cm	CC=145mm

○

6-8 mm	2 x ∅8mm
40 cm	CC=350mm

○



MAMPARA NICOLE

NEGRO
NOIR
BLACK
NERO
ON

INOX BRILLO
INOX POLI
P. S. S.
INOX LUCIDO
22

NEGRO
NOIR
BLACK
NERO
ON

INOX BRILLO
INOX POLI
P. S. S.
INOX LUCIDO
22

KITS

1 PUERTA
180°



HASTA 200 CM / VIDRIO 8 MM

KIT 180° BASE

Kit compuesto por:

- 4260/2.. 2 u.
- 4261/0.. 2 u.
- 4262/0.. 2 u.
- 4263/0.. 2 u.
- 4266/0.. 1 u.
- 4264/0.. 2 u.
- 4265/0.. 2 u.
- 4047/032 1 u.
- 1839/209 2,2 m (8 mm)

4270/B..

€/U

KIT 180° BASE

+ U INOX

- 4260/2.. 2 u.
- 4261/0.. 2 u.
- 4262/0.. 2 u.
- 4263/0.. 2 u.
- 4266/0.. 1 u.
- 4264/0.. 2 u.
- 4265/0.. 2 u.
- 4047/032 1 u.
- 4376/1.. 3 m (8 mm)
- 1839/209 2,2 m (8 mm)
- 1833/109 2,2 m

4270/U..

€/U

NO incluidos:
Burlete
1831/202

1 PUERTA
+ FIJO 90°



HASTA 100X100 CM / VIDRIO 8 MM

KIT 1 puerta + fijo 90°
BASE

Kit compuesto por:

- 4260/2.. 2 u.
- 4261/0.. 2 u.
- 4262/0.. 2 u.
- 4263/0.. 2 u.
- 4266/0.. 1 u.
- 4264/0.. 2 u.
- 4265/0.. 2 u.
- 4268/0.. 1 u.
- 4047/032 1 u.
- 1839/209 2,2 m (8 mm)

4272/B..

€/U

KIT 90°

+ U INOX

- 4260/2.. 2 u.
- 4261/0.. 2 u.
- 4262/0.. 2 u.
- 4263/0.. 2 u.
- 4266/0.. 1 u.
- 4264/0.. 2 u.
- 4265/0.. 2 u.
- 4268/0.. 1 u.
- 4047/032 1 u.
- 4376/1.. 6 m (8 mm)
- 1839/209 2,2 m (8 mm)
- 1833/109 2,2 m

4272/U..

€/U

NO incluidos:
Burlete
1831/202

KITS

2 PUERTAS
90°



HASTA 100X100 CM / VIDRIO 8 MM

KIT 90° BASE

Kit compuesto por:

- 4260/2.. 2 u.
- 4261/0.. 4 u.
- 4262/0.. 4 u.
- 4263/0.. 4 u.
- 4266/0.. 2 u.
- 4264/0.. 2 u.
- 4265/0.. 4 u.
- 4267/0.. 1 u.
- 4047/032 2 u.
- 1839/209 4,4 m (8 mm)

4271/B..

€/U

KIT 90° BASE

+ U INOX

- 4260/122 2 m.
- 4261/022 4 u.
- 4262/022 4 u.
- 4263/022 4 u.
- 4266/022 2 u.
- 4264/022 2 u.
- 4265/022 4 u.
- 4267/022 1 u.
- 4047/032 2 u.
- 4376/122 6 m (8 mm)
- 1839/209 4,4 m (8 mm)

4271/U..

€/U

NO incluidos:
Burlete
1831/202
1866/209 2,2 m (8 mm)
1867/209 2,2 m (10 mm)



- peso max: 50 kg/puerta (180° y 90°+fijo)
- peso max: 25 kg/puerta (2 puertas 90°)
- vidrio puerta: 8-10 mm (max. 90 cm rec.)
- poids max: 50 kg/porte (180° et 90°+fixe)
- poids max: 25 kg/porte (2 portes 90°)
- verre porte: 8-10 mm (max. 90 cm rec.)
- max weight: 50 kg/door (180° and 90°+fixed)
- max weight: 25 kg/door (2 doors 90°)
- glass door: 8-10 mm (max. 90 cm rec.)
- peso max: 50 kg/porta (180° e 90°+fisso)
- peso max: 25 kg/porta (12 porte 90°)
- vetro porta: 8-10 mm (max. 90 cm rec.)

COMPONENTES NICOLE



CARRIL
COULISSE HAUTE
UPPER TRACK
GUIDA SUPERIORE
4260/2..
4260/3..



COJINETE
CHARLOT
ROLLER
CUSCINETTO
4261/0..



TOPE SEGURIDAD
EPINGLE DE SÛRETÉ
SAFETY PIN
PERNO DI SICUREZZA
4262/0..



ANCLAJE VID.FIJO -CARRIL
FIXATION VERRE-COULISSE
CONNEXION GLASS-TRACK
CONNESSIONE VETRO-GUIDA
4263/0..



CONEXIÓN TUBO-PARED
FIXATION TUBE-MUR
CONNEXION TUBE-WALL
CONNESSIONE TUBO-PARETE
*4269/022



ANCLAJE CARRIL-PARED
FIXATION MUR-COULISSE
CONNEXION WALL-TRACK
CONNESSIONE PARETE-GUIDA
4264/0..



STOP INTERIOR CARRIL
STOP CHARLOT
STOP ROLLER
STOP CUSCINETTO
4265/0..



GUÍA SUELO
GUIDAGE AU SOL
FLOOR GUIDE
GUIDA A PAVIMENTO
4266/0..



CONEXIÓN 90° CARRIL
FIXATION COULISSE 90°
TRACKS CONNEXION 90°
CONNESSIONE GUIDE 90°
4267/0..



CONEXIÓN 90° CARRIL-VID. FIJO
FIXATION VERRE-COULISSE
CONNEXION GLASS-TRACK
CONNESSIONE VETRO-GUIDA
4268/022



REMATE FINAL CARRIL
BOUCHON COULISSE
END-CAP TRACK
COPRITESTA TUBO
*4275/022



POMO
POIGNÉE
KNOB
POMO
4047/0..



'U' INOX PULIDO
U INOX POLI
U POL. STAINLESS STEEL
U INOX LUCIDO
15x15x15x1 mm
4375/122
15x12x15x1 mm
4376/122
25x15x25x1 mm
4377/122

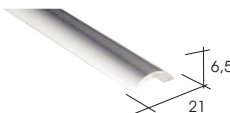

PERFIL BURLETE
PROFILE LEVRE-UO
LIP-UP PROFILE
PROFILO VERTIACQUE
1831/202

NEGRO NOR BLACK NERO	INOX S.S.	BR POLI P.S.S. INOX LUC	CR. BRILLO CHR. POLI BR. CHR. CR. LUC.
ON	22	32	

inox s.s.	L	2/3 m	
	30x10x1,5	€/u	

inox s.s.	8-10 mm	20kg/u	€/u
Ø	15 mm		

inox s.s.	8-10 mm	€/u
Ø	8 mm	

inox s.s.	8-10 mm	€/u
Ø	15 mm	

inox s.s.	€/u
-----------	-----

inox s.s.	€/u
-----------	-----

inox s.s.	€/u
-----------	-----

inox s.s.	8-10 mm	€/u
-----------	---------	-----

inox s.s.	€/u
-----------	-----

inox s.s.	8-10 mm	€/u
Ø	1210 mm	

inox s.s.	€/m
-----------	-----

Cu	6-8 mm	
Ø	10 mm	€/u

inox s.s.	L	3 m	€/m
-----------	---	-----	-----

	max. 12 mm	
--	------------	--

	max. 8 mm	
--	-----------	--

	max. 12 mm	
--	------------	--

Al	L	2 m	21x6,5	€/u
----	---	-----	--------	-----



'U' ALUMINIO
u aluminium
u alluminio
u aluminio
Al **1659/10N**
5m / 15x15x15x1,5
Al **1657/10N**
6m / 12x12x12x1,5

NEGRO NOR BLACK NERO	PL. BR ALU. BR ALL. BR	PLÁSTICO PLASTIQUE PLASTIC PLASTICA
ON	02	09

	5/6 M
--	-------

max.	10 mm
max.	8 mm

pvc	L	2,2 m	8-10 mm	€/u
-----	---	-------	---------	-----

pvc	L	2,2 m	8-10 mm	€/u
-----	---	-------	---------	-----

	8 mm	
	10 mm	

pvc	L	2,2 m	€/m
-----	---	-------	-----

	8-10 mm	
	2,5 M	
	8-10 mm	

€/M Pla	1811/109
---------	-----------------

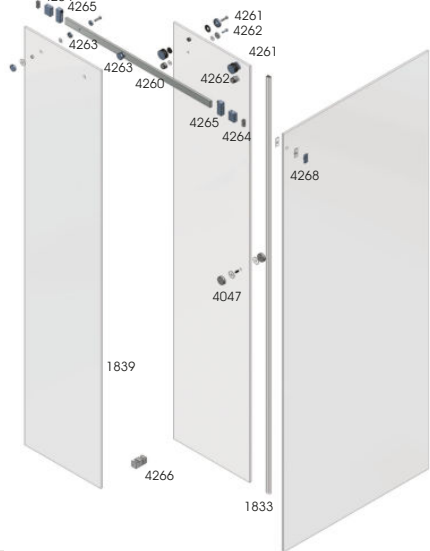
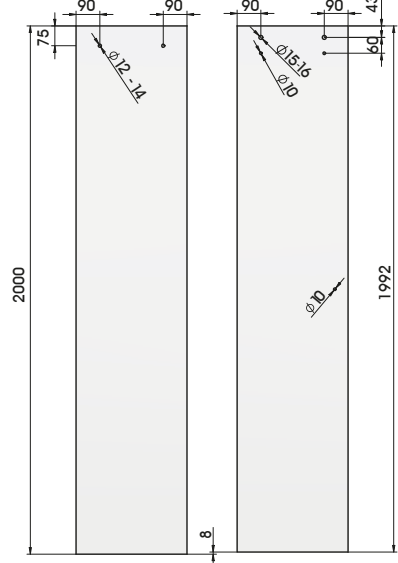
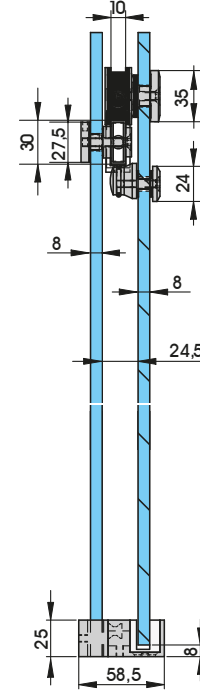
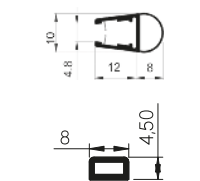
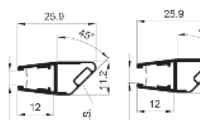

MAMPARA BEGUR



MAMPARA DE
DUCHA
DESlizANTE-ABATIBLE

Más allá de las soluciones convencionales, la mampara de ducha presenta una tecnología de apertura única. Las puertas se deslizan alojándose elegantemente en el lado fijo de la mampara.

ESPECIFICACIONES

Material: inox 304, aluminio
Acabado: pulido, negro mate
Aplicación: Apertura corredera de esquina de 90
Grosor de la puerta: 8-10 mm
Peso máximo de la puerta: 50 kg
Ancho máximo de la puerta: 1000 mm

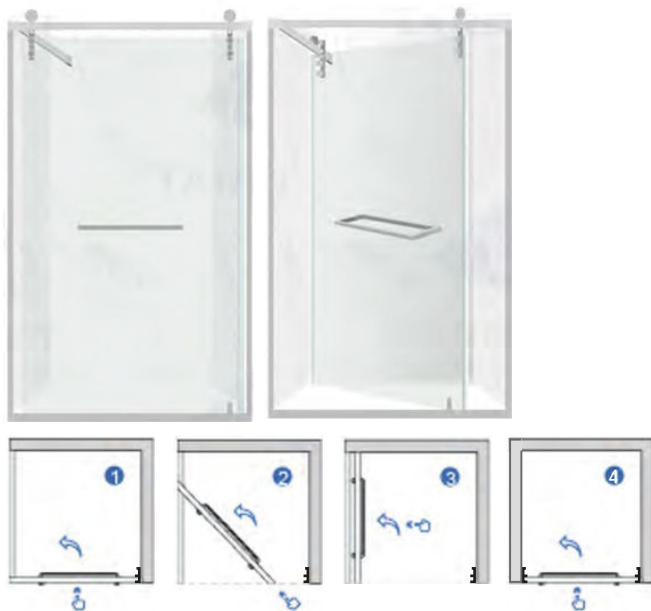

El estándar de
1000x1000x2000mm
incluye:

- X2 cojinetes
- X1 rueda deslizante inferior
- X2 soportes de tubo
- X1 carril 90°
- X1 tope de riel inferior
- X2 carril
- (30 x 10 mm, L = 1000 mm)
- X1 perfil de aluminio para guía de suelo
- (L = 1000 mm)
- X2 perfiles de aluminio a pared
- (L = 2000 mm)
- X2 juntas magnéticas de 180°
- (L = 2000 mm)

KITS

4290/0..

INOX BRILLO	NEGRO
INOX POLI	NOIR
P. S. S.	BLACK
INOX LUCIDO	NERO
22	ON

€/u

o

o



MAMPARA CANNES

VIDRIO RECOMENDADO 8MM

P.L. BR	NEGRO
ALU. BR	NOR
P.ALU. BR	BLACK
ALL. LUC	NERO
02	0N

KITS

KIT MAMPARA FIJA CANNES

Kit compuesto por:

- (x1) Perfil de aluminio a pared 195 cm
- (x1) Tapa remate superior
- (x1) Junta vidrio 8 mm
- (x1) Barra de refuerzo 90°

1673/2..

Al €/u

o o



Perfil fijo: 2 metros
Barra de refuerzo: hasta 1,20 metros
(con posibilidad de corte)



KIT COMPLETO LISTO PARA SER INSTALADO



MAMPARA CUADRO

VIDRIO RECOMENDADO 8-10 MM



Alta calidad
Acabado negro
anodizado



KITS DISPONIBLES

 PUERTA MÓVIL
 VIDRIO FIJO

QUADRO
180°

DERECHA

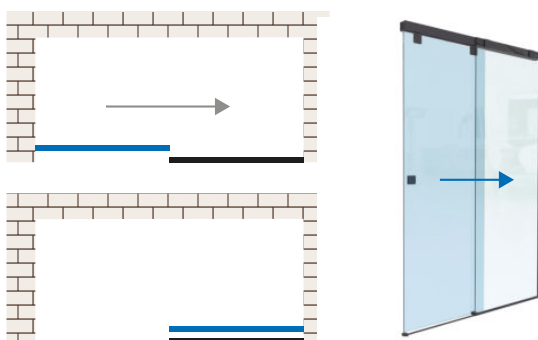

QUADRO
90°

DERECHA

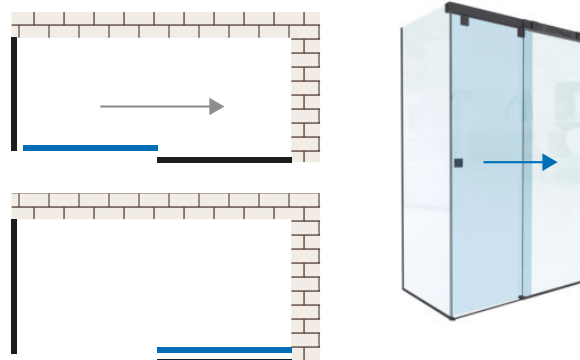

QUADRO
180°

IZQUIERDA

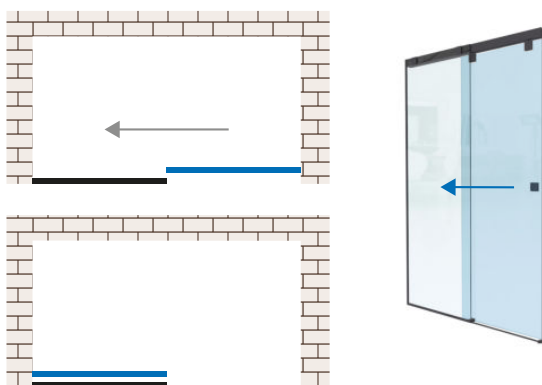

QUADRO
90°

IZQUIERDA

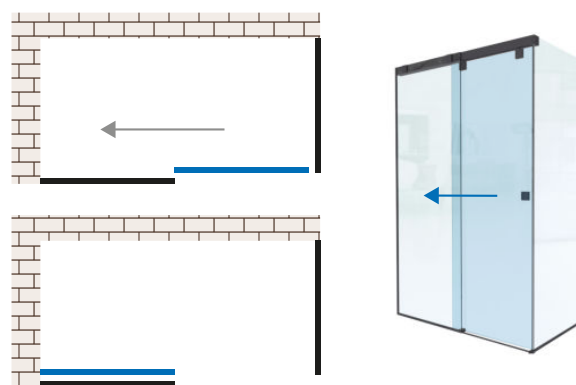

DATOS GENERALES

MATERIALES



VIDRIO

Puerta de vidrio /
Marco en
aluminio negro

Vidrio de 8 / 10 mm

* Disponible stock en acabado negro.
Para otros acabados, consultar pedido
mínimo y plazo de entrega.

PESO



30 Kg max
por cojinete

CARACTERÍSTICAS

Deslizamiento suave
Soft-closing en apertura y cierre
Posibilidad de instalación
en 180° o 90°

INSTALACIÓN 180°

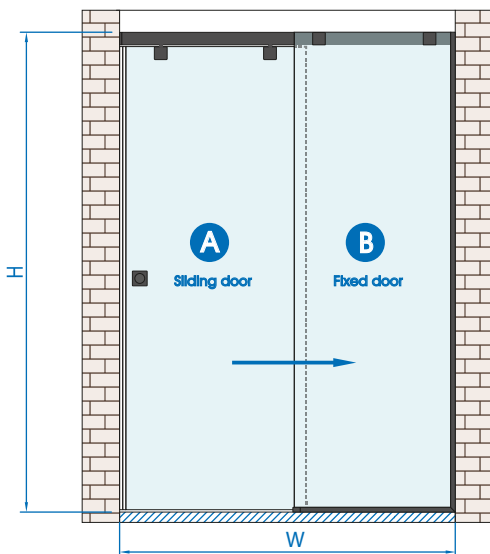
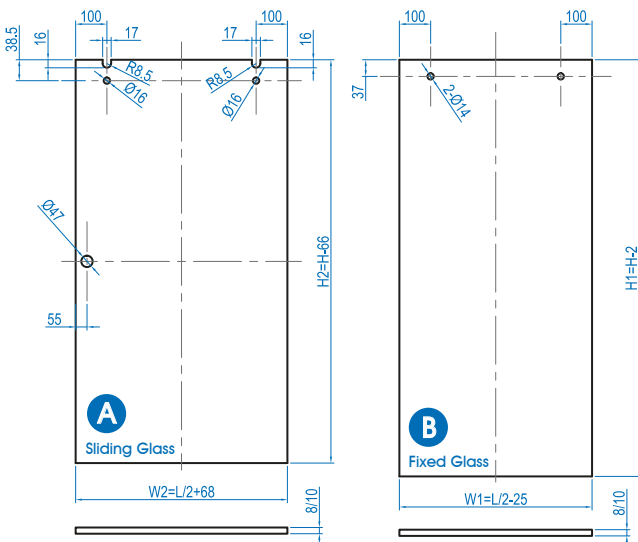

INSTALACIÓN 90°

* Instalación igual que la
de 180° añadiendo la
segunda puerta fija a
90°.

PUERTA FIJA 90° :

Sliding Glass / Fixed Glass

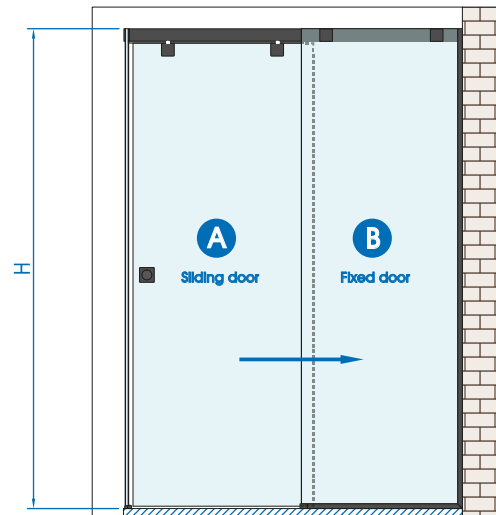
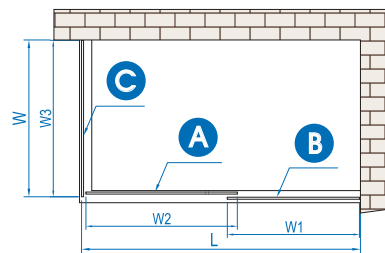
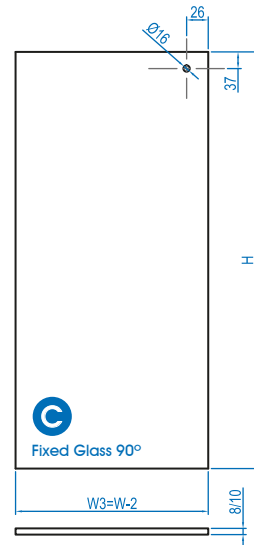

NEGRO
NOIR
BLACK
NERO
ON

KITS MAMPARA COMPLETA

180° DER.



X1	5510/25N o 5510/12N	KIT CARRIL 2450 MM	
X1	5517/25N	*5535/25N	* O
X1	5516/25N o 5516/12N		
X1	5518/00N OPCIONAL	KIT CARRIL 1220 MM	
X1	5532/00N		
X1	5512/00N	*5535/12N	* O

180° IZQ.



X1	5510/25N o 5510/12N	KIT CARRIL 2450 MM	
X1	5517/25N	*5536/25N	* O
X1	5516/25N o 5516/12N		
X1	5518/00N OPCIONAL	KIT CARRIL 1220 MM	
X1	5532/00N		
X1	5511/00N	*5536/12N	* O

90° DER.



X1	5510/25N o 5510/12N	KIT CARRIL 2450 MM	
X1	5517/25N	*5537/25N	* O
X1	5516/25N o 5516/12N		
X1	5518/00N OPCIONAL	KIT CARRIL 1220 MM	
X1	5532/00N		
X1	5514/00N	*5537/12N	* O

90° IZQ.



X1	5510/25N o 5510/12N	KIT CARRIL 2450 MM	
X1	5517/25N	*5538/25N	* O
X1	5516/25N o 5516/12N		
X1	5518/00N OPCIONAL	KIT CARRIL 1220 MM	
X1	5532/00N		
X1	5513/00N	*5538/12N	* O

INSTALACIÓN 180°

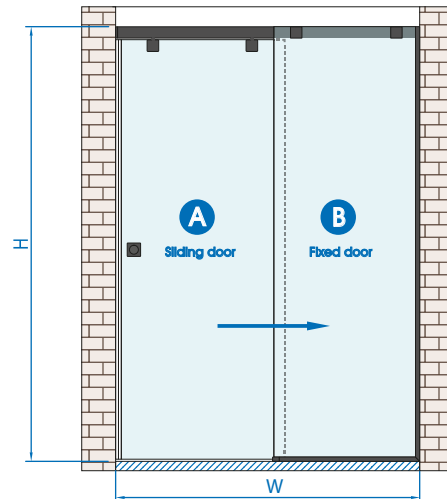
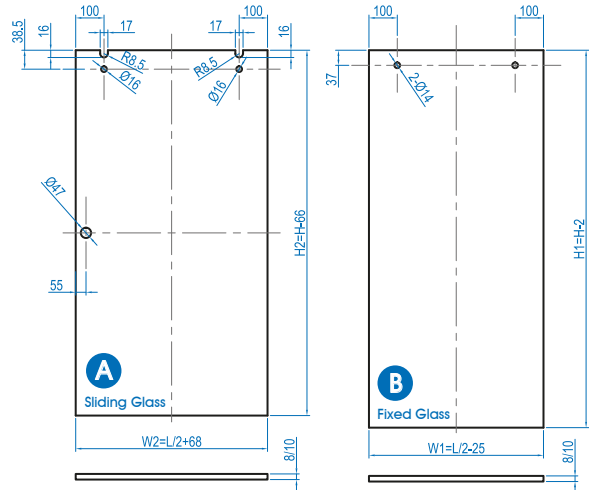

INSTALACIÓN 90°

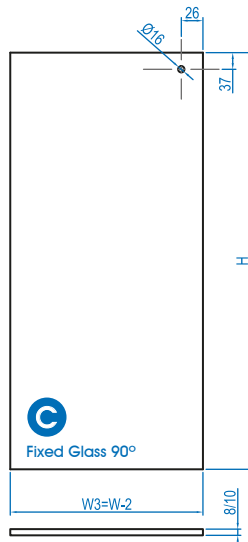
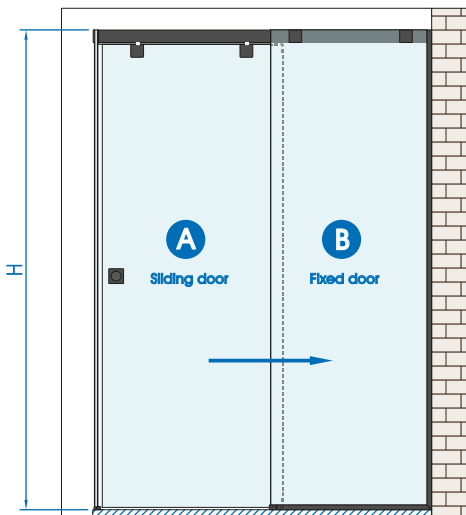

* Instalación Igual que la de 180° añadiendo la segunda puerta fija a 90°.

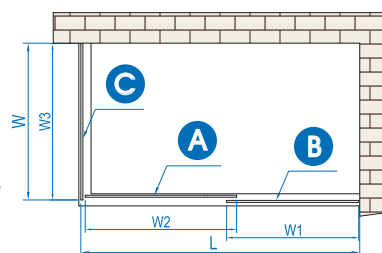

MAMPARA CUADRO

NEGRO
NOIR
BLACK
NERO
ON

KITS COJINETES I VIDRIO FIJO PUERTA

KIT COJINETES, ANCLAJES Y BUFFERS



x2: 5520/00N



x2: 5523/00N



x2: 5515/000

KIT: 2 COJINETES DE PUERTA MÓVIL + 2 ANCLAJES PARA FIJO + 2 BUFFERS (ASIMÉTRICOS)
KIT : 2 ROULEMENTS DE PORTE MOBILES + 2 ANCRAGES FIXES + 2 TAMPONS (ASYMMÉTRIQUES)
KIT: 2 MOVABLE DOOR BEARINGS + 2 FIXED ANCHORS + 2 BUFFERS (ASYMMETRIC)
KIT: 2 CUSCINETTI PORTA MOBILI + 2 ANCORAGGI FISSI + 2 TAMPONI (ASIMMETRICI)
***5532/00N selfclosing**

Al	51,5mm	8-10	€/u
	Ø47mm		

peso max: 30 kg/cojinete
vidrio de 8-10 mm
soft-closing en apertura y cierre

PIEZAS COMUNES MARCO

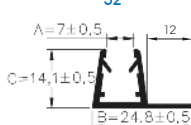
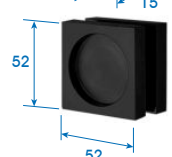
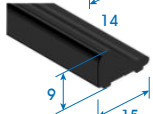
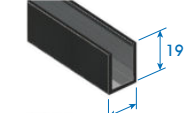
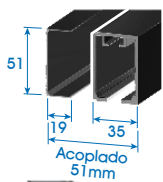

CARRIL Y TAPA INTERIOR DE CARRIL
RAIL ET CHAPEAU DE RAIL
RAIL AND RAIL CAP
BINARIO E CAPPUCCIO DEL BINARIO

Al	8-10	€/u
	2450 mm / 1225 mm	

* taladro para sujeción del fijo

***5510/25N**
***5510/12N**

"U" DE FIJACIÓN
FIXATION EN "U"
"U" FIXING
FISSAGGIO A "U"
***5517/25N**

Al	2450mm	8-10	€/u
----	--------	------	-----

PERFIL VIERTEAGUAS
RAIL DE GUIDAGE AU SOL
FLOOR GUIDE RAIL
BINARIO DI GUIDA A PAVIMENTO
***5516/25N**
***5516/12N**

Al	2450mm	€/u
	1225mm	

UNERO
POIGNEÉ
KNOB
POMO
***5518/00N**

Al	52x52mm	8-10	€/u
	Ø47mm		

PERFIL LATERAL CORREDERA
PROF. ÉTANCHÉITE COULISSANT
SLIDING DOOR SEAL
SCORREVOLE
***1855/109**

Pvc	2,2m	10	€/u
-----	------	----	-----

KITS ACCESORIOS

NEGRO
NOIR
BLACK
NERO
ON



KIT DE TAPAS LATERALES DEL CARRIL SUPERIOR, Y GUIADOR Y TOPE DE SUELO
KIT DE CACHES LATÉRAUX DE RAIL SUPÉRIEUR, GUIDE ET BUTÉE AU SOL
KIT OF TOP RAIL SIDE COVERS, AND GUIDE AND FLOOR STOP
KIT COPERTURE LATERALI BINARIO SUPERIORE, GUIDA E BATTUTA A PAVIMENTO
***5512/00N**

180° DER.

Al	€/u
5516 (5524-27)	5510 (5521-22)

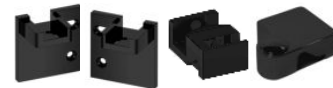

x1 5521/00N x1 5522/00N x1 5524/00N x1 5527/00N



KIT DE TAPAS LATERALES DEL CARRIL SUPERIOR, Y GUIADOR Y TOPE DE SUELO
KIT DE CACHES LATÉRAUX DE RAIL SUPÉRIEUR, GUIDE ET BUTÉE AU SOL
KIT OF TOP RAIL SIDE COVERS, AND GUIDE AND FLOOR STOP
KIT COPERTURE LATERALI BINARIO SUPERIORE, GUIDA E BATTUTA A PAVIMENTO
***5511/00N**

180° IZQ.

Al	€/u
5516 (5525-26)	5510 (5521-22)



x1 5522/00N x1 5525/00N x1 5526/00N



KIT DE TAPAS LATERALES DEL CARRIL SUPERIOR, Y GUIADOR Y TOPE DE SUELO
KIT DE CACHES LATÉRAUX DE RAIL SUPÉRIEUR, GUIDE ET BUTÉE AU SOL
KIT OF TOP RAIL SIDE COVERS, AND GUIDE AND FLOOR STOP
KIT COPERTURE LATERALI BINARIO SUPERIORE, GUIDA E BATTUTA A PAVIMENTO
***5514/00N**

90° DER.

Al	€/u
5516 (5524-29)	5510 (5522-31)



x1 5522/00N x1 5531/00N x1 5524/00N x1 5529/00N



KIT DE TAPAS LATERALES DEL CARRIL SUPERIOR, Y GUIADOR Y TOPE DE SUELO
KIT DE CACHES LATÉRAUX DE RAIL SUPÉRIEUR, GUIDE ET BUTÉE AU SOL
KIT OF TOP RAIL SIDE COVERS, AND GUIDE AND FLOOR STOP
KIT COPERTURE LATERALI BINARIO SUPERIORE, GUIDA E BATTUTA A PAVIMENTO
***5513/00N**

90° IZQ.

Al	€/u
5516 (5525-28)	5510 (5521-30)



x1 5521/00N x1 5530/00N x1 5525/00N x1 5528/00N

MAMPARA TONDO

Peso max: 40 kg/puerta

Vidrio: 8-10 mm

Poids max: 40 kg/porte

Verre: 8-10 mm

Max weight: 40 kg/door

Glass: 8-10 mm

Peso max: 40 kg/porta

Vetro: 8-10 mm

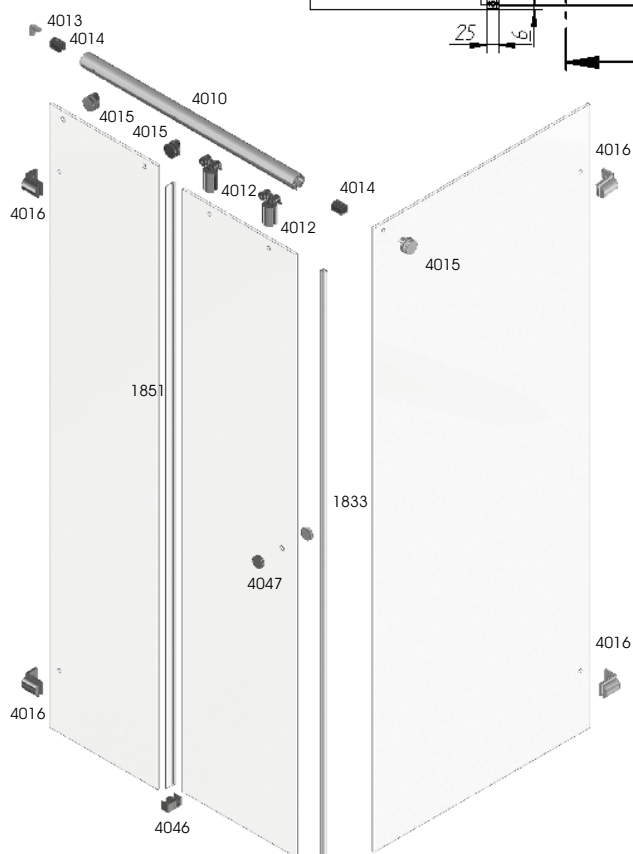
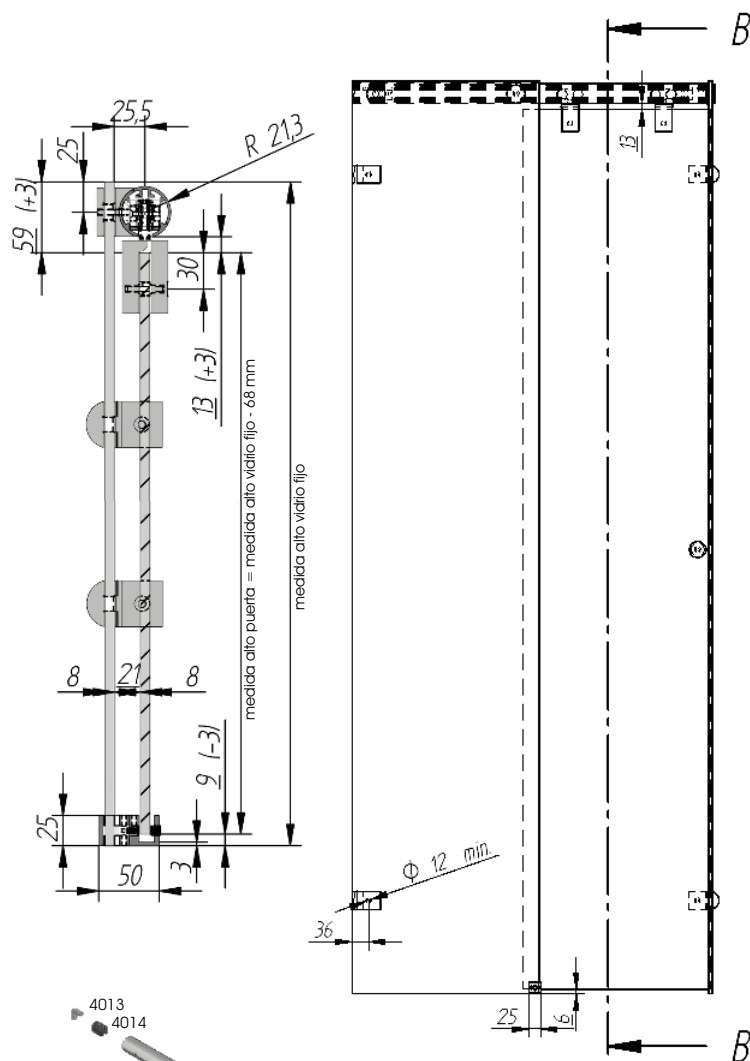

COMPONENTES TONDO



CARRIL
COULISSE HAUTE
UPPER TRACK
GUIDA SUPERIORE
*4010/102

PL. BR	CR. BRILLO	PLÁSTICO
ALU. BR	CHR. POLI	PLASTIQUE
ALU. LUC	CR. LUC.	PLASTICA

02	32	09
Al	2 m	Ø43

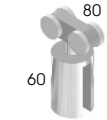

COJINETE
CHARLOT
ROLLER
CUSCINETTO
*4011/032

Cu	20 kg/u	8-10 mm	€/u
		Ø 14-15 mm	



ANCLAJE VID.FIJO -CARRIL
FIXATION VERRE-COULISSE
CONNEXION GLASS-TRACK
CONNESSIONE VETRO-GUIDA
*4012/032

Cu	8-10 mm	€/u
		Ø 14-15 mm



ANCLAJE CARRIL-PARED
FIXATION MUR-COULISSE
CONNEXION WALL-TRACK
CONNESSIONE PARETE-GUIDA
*4013/032

Cu	€/u
----	-----



STOP INTERIOR CARRIL
STOP CHARLOT
STOP ROLLER
STOP CUSCINETTO
*4014/009

plac	€/u
------	-----



CONEXIÓN 90° CARRIL-VID.FIJO
FIXATION VERRE-COULISSE
CONNEXION GLASS-TRACK
CONNESSIONE VETRO-GUIDA
*4015/032

Cu	8-10 mm	€/u
		Ø 14-15 mm



GUÍA SUELO
GUIDAGE AU SOL
FLOOR GUIDE
GUIDA A PAVIMENTO
4046/032

Cu	6-10 mm	€/u
----	---------	-----



MORSETO VIDRIO-PARED
FIXATION VERRE-MUR
BRACKET GLASS-WALL
MORSETTO VETRO-PARETE
*4016/032

Cu	8-10 mm	€/u
		Ø 14-15 mm



POMO
POIGNEE
KNOB
POMO
4047/032

Cu	6-8 mm	€/u
		Ø 10 mm



"U" INOX PULIDO
U INOX POLI
U POLISHED STAINLESS STEEL
U INOX LUCIDO

Inox s.s.	3 m	€/m
-----------	-----	-----

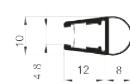

PERFIL MAMPARAS
PROF ETANCHEITE
SEAL
GIUNTA
1833/109

pvc	2,2 m	8-10 mm	€/m
-----	-------	---------	-----



PERFIL LATERAL CORREDERA
PROF ETANCHEITE COULISSENT
SLIDING DOOR SEAL
GIUNTA PORTA SCORREVOLE
1851/109

pvc	2,2 m	8 mm	€/m
-----	-------	------	-----

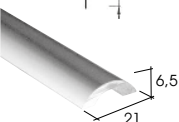

PERFIL BURLETE DE ALUMINIO
PROFILE LEVRE-UO
LIP-UP PROFILE
PROFILO VERTICACQUE
1831/202

Al	2 m	21X6,5	€/m
----	-----	--------	-----

KITS

CR. BRILLO	CHR. POLI	BR. CHR	CR. LUC.
32			



KIT 1 puerta + fijo 90°
1 PORTE + 1 FIXE 90°
1 DOOR + 1 FIXED 90°
1 PORTA + 1 FISSO 90°

KIT BASE

4010/102 2 m.
4011/032 2 u.
4012/032 2 u.
4013/032 1 u.
4014/009 2 u.
4015/032 1 u.
4046/032 1 u.
4047/032 1 u.

1851/109 2,2 m (8 mm)
*4018/B32

KIT BASE + U INOX

4010/102 2 m.
4011/032 2 u.
4012/032 2 u.
4013/032 1 u.
4014/009 2 u.
4015/032 1 u.
4046/032 1 u.
4047/032 1 u.
1851/109 2,2 m (8 mm)
4376/122 6 m (8 mm)
1833/109 2,2 m (8-10mm)

*4018/U32

KIT BASE + 4016

4010/102 2 m.
4011/032 2 u.
4012/032 2 u.
4013/032 1 u.
4014/009 2 u.
4015/032 1 u.
4046/032 1 u.
4047/032 1 u.
1851/109 2,2 m (8 mm)
4016/032 4 u.
1833/109 2,2 m (8-10mm)

*4018/M32

NO incluidos:
1831/132

KIT 1 puerta 180°

1 PORTE 180°
1 DOOR 180°
1 PORTA 180°

KIT BASE

4010/102 2 m.
4011/032 2 u.
4012/032 2 u.
4013/032 2 u.
4014/009 2 u.
4046/032 1 u.
4047/032 1 u.
1851/109 2,2 m (8 mm)

*4017/B32

KIT BASE + U INOX

4010/102 2 m.
4011/032 2 u.
4012/032 2 u.
4013/032 2 u.
4014/009 2 u.
4046/032 1 u.
4047/032 1 u.
1851/109 2,2 m (8 mm)
4376/122 3 m (8 mm)
1833/109 2,2 m (8-10mm)

*4017/U32

KIT BASE + 4016

4010/102 2 m.
4011/032 2 u.
4012/032 2 u.
4013/032 2 u.
4014/009 2 u.
4046/032 1 u.
4047/032 1 u.
1851/109 2,2 m (8 mm)
4016/032 2 u.
1833/109 2,2 m (8-10mm)

*4017/M32

NO incluidos:
1831/132

HASTA 200 CM VIDRIO 8 MM

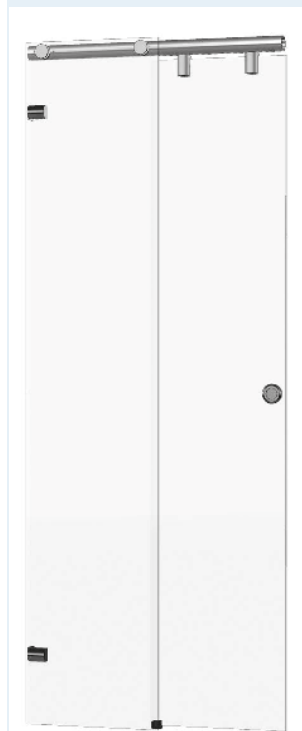

HASTA 200 CM VIDRIO 8 MM



GALGA AGUJEROS 4010
OUTIL FORAGE 4010
TOOL TO DRILL 4010
UTENSILE PER FORARE 4010
*4019/000

€/u

*o

NEMO

- peso max: 40 kg/puerta (180° y 90°+fijo)
- peso max: 20 kg/puerta (2 puertas 90°)
- vidrio: 6-8 mm

- poids max: 40 kg/porte (180° et 90°+fixe)
- poids max: 20 kg/port (2 portes 90°)
- verre: 6-8 mm

- max weight: 40 kg/door (180° and 90°+fixed)
- max weight: 20 kg/door (2 doors 90°)
- glass: 6-8 mm

- peso max: 40 kg/porta (180° e 90°+fissjo)
- peso max: 20 kg/porta (2 porte 90°)
- vetro: 6-8 mm

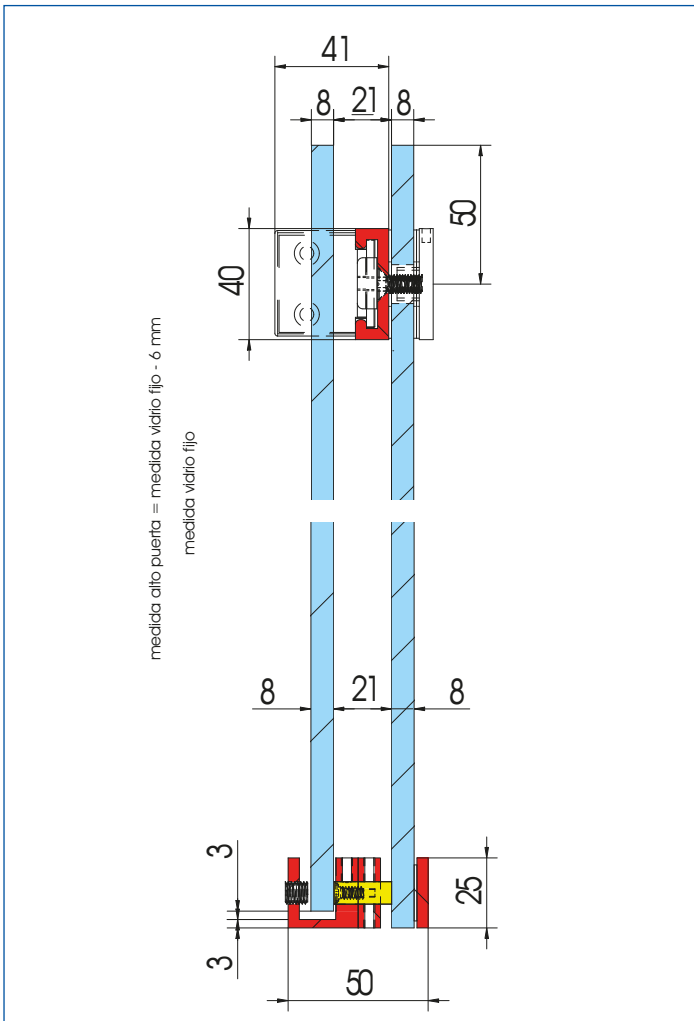
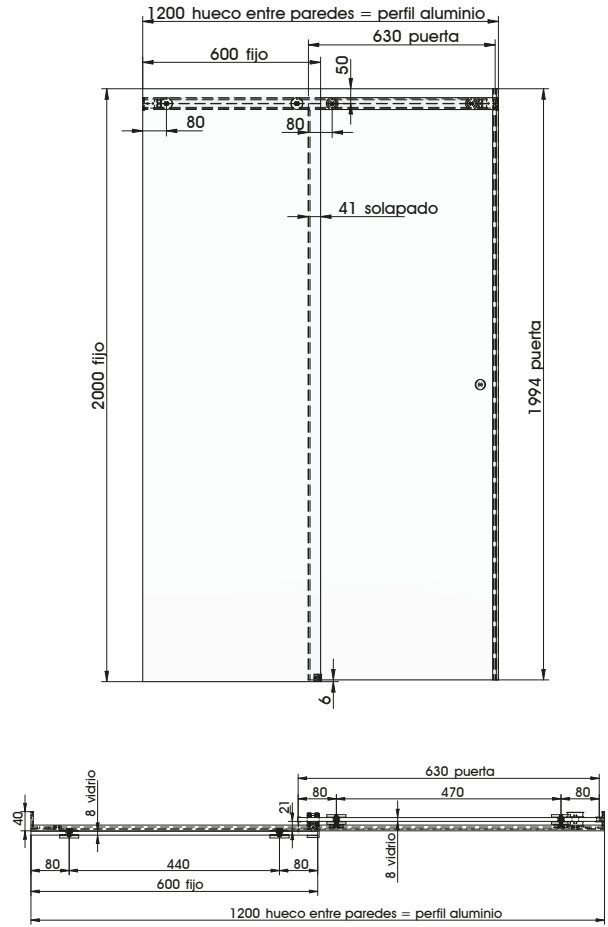

cotek.

DUCHA

BISAGRAS Y HERRAJES

GAMA PREMIUM

HERRAJES ALTA GAMA - BISAGRAS

KITS Y COMPONENTES

BISAGRAS CON RETENCIÓN

TEIDE
MALLORCA PLUS
MALLORCA
MALLORCA REGULABLE
IBIZA
LANZAROTE
MALLORCA HIDRÁULICA
TENERIFE
LUGO
MENORCA REGULABLE
MENORCA
BILBAO
ALICANTE
NIZA PLUS

BISAGRAS SIN RETENCIÓN

NIZA
LISBOA
VENECIA
MONACO
VALENCIA, CURVO Y JEREZ TIVOLI

HERRAJES FIJOS

PERFILES FIJOS
PERFIL CANNES

BARRAS DE REFUERZO
TELESCÓPICAS 90°
NO EXTENSIBLES
PARA VIDRIOS

PORTAESTANTES
DISTANCIADORES SUELO
CIERRES LAVABOS

PERIMETRALES

TUBO CUADRADO 19X19
TUBO RECTANGUL. 30X10
TUBO CILÍNDRICO 19

POMOS, TIRADORES Y UÑEROS

POMOS
TIRADORES
TIRADORES TOALLEROS
UÑEROS

TOPES, TOALLEROS Y PORTAROLLOS

TAPAJUNTAS

TAPAJUNTAS
TAPAJUNTAS IMANTADOS
TAPAJUNTAS ADHESIVAS
TAPAJUNTAS CORREDERAS
TAPAJUNTAS PLEGABLES
BURLETES ALUMINIO SUELO
BURLETES ADHESIVO SUELO

FORMATO BAÑERA
FORMATO DUCHA

ROMA QUADRANT
ROMA
ARNO

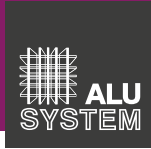

BISAGRAS GAMA PREMIUM

DUBAI (BASCULANTE) - HIDRÁULICA Regulable

ON 32



BISAGRA DESPLAZADA VIDRIO-PARED <i>charnière déplacée verre-mur</i> <i>displaced hinge glass-wall</i> <i>cearniera spostata vetro-parete</i>	8-10 mm 50.000 ciclos 0°-90°-180°	5600/0.. DERECHA 5601/0.. IZQUIERDA	<input type="radio"/>	<input type="radio"/>	
BISAGRA VIDRIO-VIDRIO <i>charnière verre-verre</i> <i>hinge glass-glass</i> <i>cearniera vetro-vetro</i>	8-10 mm 50.000 ciclos 0°-90°-180°	5602/0.. DERECHA 5603/0.. IZQUIERDA	<input type="radio"/>	<input type="radio"/>	

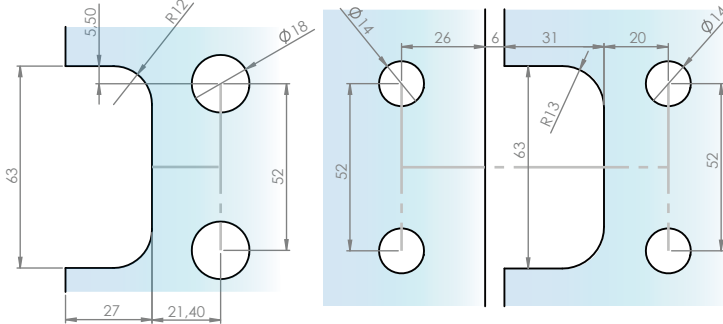

5600/0.. 5601/0..

5602/0.. 5603/0..



DAKAR (VIDRIO LAMINADO)

ON 32

BISAGRA DESPLAZADA VIDRIO-PARED <i>charnière déplacée verre-mur</i> <i>displaced hinge glass-wall</i> <i>cearniera spostata vetro-parete</i>	8-10 mm 80.000 ciclos 0°-90°-180°	5610/0..	<input type="radio"/>	<input type="radio"/>	
BISAGRA VIDRIO-VIDRIO 180° <i>charnière verre-verre 180°</i> <i>hinge glass-glass 180°</i> <i>cearniera vetro-vetro 180°</i>	8-10 mm 80.000 ciclos 0°-90°-180°	5611/0..	<input type="radio"/>	<input type="radio"/>	
BISAGRA VIDRIO-VIDRIO 90° <i>charnière verre-verre 90°</i> <i>hinge glass-glass 90°</i> <i>cearniera vetro-vetro 90°</i>	8-10 mm 80.000 ciclos 0°-90°-180°	5612/0..	<input type="radio"/>	<input type="radio"/>	

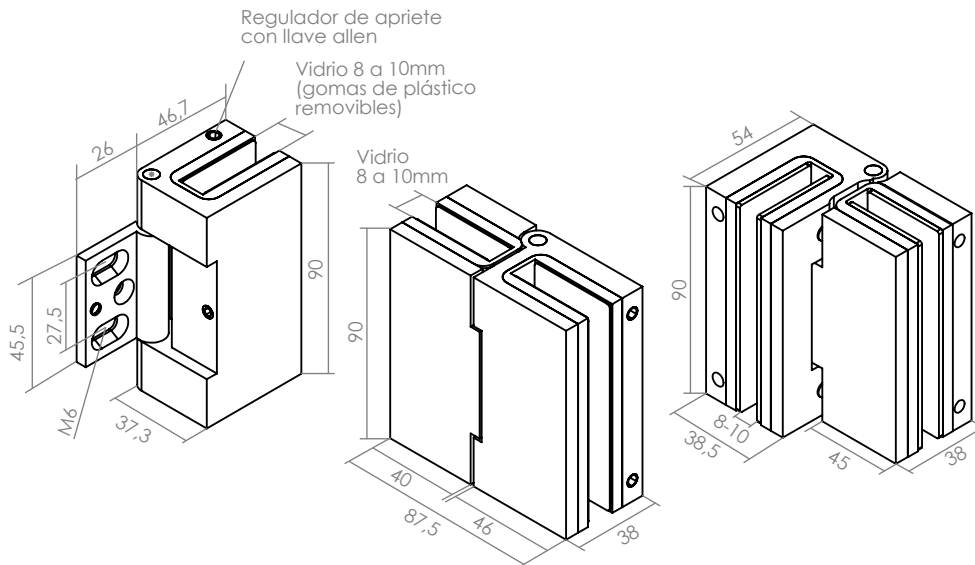



MEMPHYS Regulable

ON 32

BISAGRA DESPLAZADA VIDRIO-PARED <i>charnière déplacée verre-mur</i> <i>displaced hinge glass-wall</i> <i>cerniera spostata vetro-parete</i>	8-10 mm 0°-90°-180° (R)	50.000 ciclos	22,5 kg Cu 5505/0.. €/u.	○	○	
	BISAGRA VIDRIO-VIDRIO <i>charnière verre-verre</i> <i>hinge glass-glass</i> <i>cerniera vetro-vetro</i>	8-10 mm 0°-90°-180° (R)	50.000 ciclos	22,5 kg Cu 5506/0.. €/u.	○	○

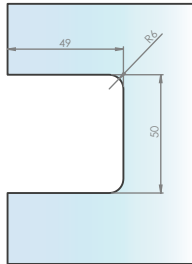

5505/0..

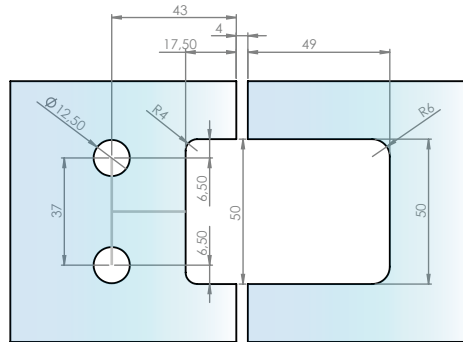

5506/0..



DALLAS Regulable

ON 32

BISAGRA DESPLAZADA VIDRIO-PARED <i>charnière déplacée verre-mur</i> <i>displaced hinge glass-wall</i> <i>cerniera spostata vetro-parete</i>	8-10 mm 0°-90°-180° (R)	50.000 ciclos	17,5 kg Cu 5500/... €/u.	○	○	
	BISAGRA VIDRIO-VIDRIO <i>charnière verre-verre</i> <i>hinge glass-glass</i> <i>cerniera vetro-vetro</i>	8-10 mm 0°-90°-180° (R)	50.000 ciclos	17,5 kg Cu 5501/... €/u.	○	○

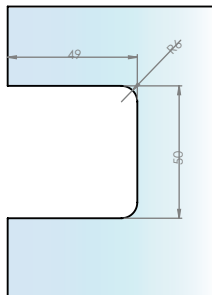

5500/...

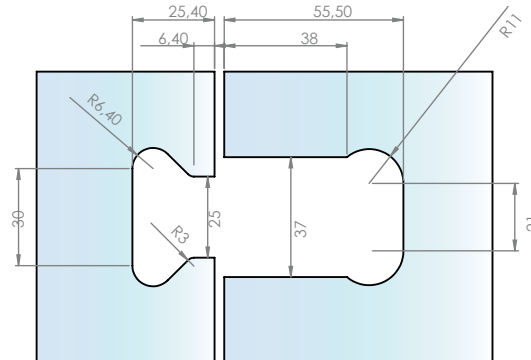

5501/...

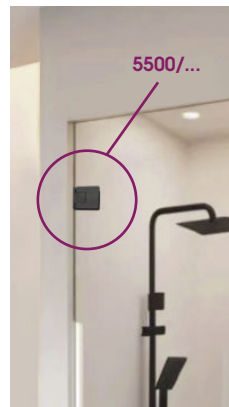



BISAGRAS CON RETENCIÓN



TEIDE 6/8				06	35	0B	0N	32	22	28
BISAGRA PARED-VIDRIO charnière mur-verre hinge wall-glass cerniera parete-vetro	6-8 mm 0°-90°-180°		18 Kg/u	EU Cu	4180/0..					
			14 Kg/u	EU Zn	4180/Z32					
			18 Kg/u	EU Inx	4180/0..					
BISAGRA DESPLAZADA PARED-VIDRIO charnière mur-verre déplacée hinge wall-glass offset cerniera parete-vetro ala spostata	6-8 mm 0°-90°-180°		18 Kg/u	EU Cu	4184/0..	*O	CONSULTAR			/022 /028
			14 Kg/u	EU Zn	4184/Z..	*O				
			18 Kg/u	EU Inx	4184/I..					
BISAGRA VIDRIO-VIDRIO 180° charnière mur-verre déplacée hinge wall-glass offset cerniera parete-vetro ala spostata	6-8 mm 0°-90°-180°		18 Kg/u	EU Cu	4181/0..	*O	CONSULTAR			/022 /028
			14 Kg/u	EU Zn	4181/Z..	*O				
			18 Kg/u	EU Inx	4181/I..					
BISAGRA VIDRIO-VIDRIO 90° charnière mur-verre déplacée hinge wall-glass offset cerniera parete-vetro ala spostata	6-8 mm 0°-90°-180°		18 Kg/u	EU Cu	4182/0..					
			18 Kg/u	EU Inx	4182/I..					
BISAGRA VIDRIO-VIDRIO 135° charnière mur-verre déplacée hinge wall-glass offset cerniera parete-vetro ala spostata	6-8 mm 0°-90°-180°		18 Kg/u	EU Cu	4183/0..					
			18 Kg/u	EU Inx	4183/I..					



MALLORCA PLUS 8/10 - TAPAS EMBELLECEDORAS				0B	0N	32	31	22	28	
BISAGRA PARED-VIDRIO charnière mur-verre hinge wall-glass cerniera parete-vetro	8-12 mm 0°-90°-180° (R)		22,5 Kg/u	EU Cu	4103/T..					
			22,5 Kg/u	EU Inx	4103/T..					
BISAGRA VIDRIO-VIDRIO 180° charnière mur-verre déplacée hinge wall-glass offset cerniera parete-vetro ala spostata	8-12 mm 0°-90°-180° (R)		22,5 Kg/u	EU Cu	4101/T..					
			22,5 Kg/u	EU Inx	4101/T..					
MALLORCA 8/10 - INOX MUESCAS DIFERENTES				LATÓN Y ZAMAK MISMA MUESCA INOX DISTINTA						
BISAGRA PARED-VIDRIO charnière mur-verre hinge wall-glass cerniera parete-vetro	8-10 mm 0°-90°-180°		22,5 Kg/u	EU Cu	4100/0..					/022 /028
			18 Kg/u	EU Zn	4100/Z32					
			22,5 Kg/u	EU Inx	4100/I..					
BISAGRA DESPLAZADA PARED-VIDRIO charnière mur-verre déplacée hinge wall-glass offset cerniera parete-vetro ala spostata	8-10 mm 0°-90°-180°		22,5 Kg/u	EU Cu	4103/0..					/022 /028
			18 Kg/u	EU Zn	4103/Z..					
			22,5 Kg/u	EU Inx	4103/I..					
BISAGRA VIDRIO-VIDRIO 180° charnière mur-verre déplacée hinge wall-glass offset cerniera parete-vetro ala spostata	8-10 mm 0°-90°-180°		22,5 Kg/u	EU Cu	4101/0..					/022 /028
			18 Kg/u	EU Zn	4101/Z..					
			22,5 Kg/u	EU Inx	4101/I..					
BISAGRA VIDRIO-VIDRIO 90° charnière mur-verre déplacée hinge wall-glass offset cerniera parete-vetro ala spostata	8-10 mm 0°-90°-180°		22,5 Kg/u	EU Cu	4102/0..					/022 /028
			22,5 Kg/u	EU Inx	4102/I..					
BISAGRA VIDRIO FIJO + 2 PUERTAS charnière mur-verre déplacée hinge wall-glass offset cerniera parete-vetro ala spostata	8-10 mm 0°-90°-180°		22,5 Kg/u	EU Cu	4104/0..					
			22,5 Kg/u	EU Inx	4104/I..					



BISAGRAS MALLORCA EKOS				0N	22		
BISAGRA PARED-VIDRIO charnière mur-verre hinge wall-glass cerniera parete-vetro	8-10 mm 0°-90°-180°		22 Kg/u	EU Inx	3100/0..		
			22 Kg/u	EU Inx	3100/0..		
BISAGRA DESPLAZADA PARED-VIDRIO charnière déplacée displaced hinge cerniera spostata	8-10 mm 0°-90°-180°		22 Kg/u	EU Inx	3103/0..		
			22 Kg/u	EU Inx	3103/0..		
BISAGRA VIDRIO-VIDRIO 180° charnière verre-verre hinge glass-glass cerniera vetro-vetro	8-10 mm 0°-90°-180°		22 Kg/u	EU Inx	3101/0..		
			22 Kg/u	EU Inx	3101/0..		



*MALLORCA REGULABLE 8/10				32			
BISAGRA PARED-VIDRIO charnière mur-verre hinge wall-glass cerniera parete-vetro	8-12 mm 0°-90°-180° (R)		22,5 Kg/u	EU Cu	REGULABLE *4100/R32	*O	
			22,5 Kg/u	EU Cu	REGULABLE *4100/R32	*O	
BISAGRA VIDRIO-VIDRIO 180° charnière mur-verre déplacée hinge wall-glass offset cerniera parete-vetro ala spostata	8-12 mm 0°-90°-180° (R)		22,5 Kg/u	EU Cu	REGULABLE *4101/R32	*O	
			22,5 Kg/u	EU Cu	REGULABLE *4101/R32	*O	

NOVEDAD

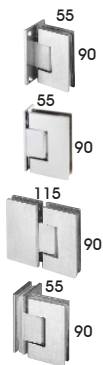

IBIZA 8/12 - INOX 316					INOX BR	INOX SAT
					INOX POLI	INOX SAT
					P.S.S.	S.S.S.
					INOX LUC	INOX SAT
					22	28
BISAGRA PARED-VIDRIO charnière mur-verre hinge wall-glass cerniera parete-vetro	8-12 mm 0°-90°-180°	22,5 Kg/u	INOX 316	€U INX 4300/0..	○	○
BISAGRA DESPLAZADA PARED-VIDRIO charnière mur-verre déplacée hinge wall-glass offset cerniera parete-vetro ala spostata	8-12 mm 0°-90°-180°	22,5 Kg/u	INOX 316	€U INX 4303/0..	○	○
BISAGRA VIDRIO-VIDRIO 180° charnière mur-verre déplacée hinge wall-glass offset cerniera parete-vetro ala spostata	8-12 mm 0°-90°-180°	22,5 Kg/u	INOX 316	€U INX 4301/0..	○	○
BISAGRA VIDRIO-VIDRIO 90° charnière mur-verre déplacée hinge wall-glass offset cerniera parete-vetro ala spostata	8-12 mm 0°-90°-180°	22,5 Kg/u	INOX 304	€U INX 4302/0..	○	○



LANZAROTE 8/12 - INOX DUPLEX 2205					INOX BR	INOX SAT
					INOX POLI	INOX SAT
					P.S.S.	S.S.S.
					INOX LUC	INOX SAT
					22	28
BISAGRA PARED-VIDRIO charnière mur-verre hinge wall-glass cerniera parete-vetro	8-12 mm 0°-90°-180°	22,5 Kg/u	INOX DUPLEX 2205	€U INX 2200/0..	○	○
BISAGRA DESPLAZADA PARED-VIDRIO charnière mur-verre déplacée hinge wall-glass offset cerniera parete-vetro ala spostata	8-12 mm 0°-90°-180°	22,5 Kg/u	INOX DUPLEX 2205	€U INX 2203/0..	○	○
BISAGRA VIDRIO-VIDRIO 180° charnière mur-verre déplacée hinge wall-glass offset cerniera parete-vetro ala spostata	8-12 mm 0°-90°-180°	22,5 Kg/u	INOX DUPLEX 2205	€U INX 2201/0..	○	○

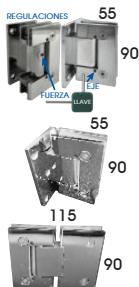

MALLORCA HIDRÁULICA 8/12					INOX BR	INOX SAT
					INOX POLI	INOX SAT
					P.S.S.	S.S.S.
					INOX LUC	INOX SAT
					22	
					MISMA MUESCA QUE LATÓN Y ZAMAK	
BISAGRA PARED-VIDRIO charnière mur-verre hinge wall-glass cerniera parete-vetro	8-12 mm 0°-90°-180°	20 Kg/u		€U INX HIDRÁULICA Y REGULABLE 4100/H22	○	
BISAGRA DESPLAZADA PARED-VIDRIO charnière mur-verre déplacée hinge wall-glass offset cerniera parete-vetro ala spostata	8-12 mm 0°-90°-180°	20 Kg/u		€U INX HIDRÁULICA Y REGULABLE 4103/H22	○	
BISAGRA VIDRIO-VIDRIO 180° charnière mur-verre déplacée hinge wall-glass offset cerniera parete-vetro ala spostata	8-12 mm 0°-90°-180°	20 Kg/u		€U INX HIDRÁULICA Y REGULABLE 4101/H22	○	

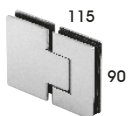

*TENERIFE 8/10 - ESTANCA 100%					INOX BR	INOX SAT
					INOX POLI	INOX SAT
					P.S.S.	S.S.S.
					INOX LUC	INOX SAT
					22	
BISAGRA VIDRIO-VIDRIO 180° charnière mur-verre hinge wall-glass cerniera parete-vetro	8-12 mm 0°-90°-180°	22,5 Kg/u	INOX 304	€U INX *4211/0..	*○	

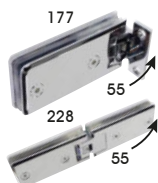

LUGO 8/10 - REGULABLE					CR. BRILLO	CR. POLI
					BR. CR	CR. LUC
					32	
BISAGRA PARED-VIDRIO charnière mur-verre hinge wall-glass cerniera parete-vetro	6-8 mm 0°-90°-180°	22,5 Kg/u		€U Cu REGULABLE 5310/R32	○	
BISAGRA VIDRIO-VIDRIO 180° charnière mur-verre déplacée hinge wall-glass offset cerniera parete-vetro ala spostata	6-8 mm 0°-90°-180°	22,5 Kg/u		€U Cu REGULABLE *5311/R32	○	



*MENORCA 8/10 - REGULABLE					CR. BRILLO	CR. POLI
					BR. CR	CR. LUC
					32	
BISAGRA PARED-VIDRIO charnière mur-verre hinge wall-glass cerniera parete-vetro	6-8 mm 0°-90°-180° (R)	22,5 Kg/u		€U Cu REGULABLE *4187/R32	*○	
BISAGRA VIDRIO-VIDRIO 180° charnière mur-verre déplacée hinge wall-glass offset cerniera parete-vetro ala spostata	6-8 mm 0°-90°-180° (R)	22,5 Kg/u		€U Cu REGULABLE *4186/R32	*○	

INOX BR INOX POLI P.S.S. INOX LUC	NEGRO NOIR BLACK NERO	CR. BRILLO CR.F. POLI BR. CR. CR. LUC	CR. MATE CR. M M. CR. CR. OPAC
--	--------------------------------	--	---



*MENORCA 8/10 - INOX

22 ON 32 31

BISAGRA PARED-VIDRIO charnière mur-verre hinge wall-glass cerniera parete-vetro	8-10 mm 0°-90°-180° 112X55	22 Kg/u	INOX 304 €U Inx *4187/022	*o			
---	----------------------------------	---------	------------------------------	----	--	--	--



*BILBAO - REFORZADA 27 KG 8/10

BISAGRA DESPLAZADA PARED-VIDRIO charnière mur-verre déplacée hinge wall-glass offset cerniera parete-vetro ala spostata	8-10 mm 0°-90°-180° 90X55	27 Kg/u	latón eje reforzado €U Cu *4212/03.			*o	*o
---	---------------------------------	---------	--	--	--	----	----



BISAGRA VIDRIO-VIDRIO 180° charnière verre-verre 180° hinge glass-glass 180° cerniera vetro-vetro 180°	8-10 mm 0°-90°-180° 115X55	27 Kg/u	latón eje reforzado €U Cu *4213/032			*o	
--	----------------------------------	---------	--	--	--	----	--



*ALICANTE 8/10

BISAGRA VIDRIO-VIDRIO 180° charnière verre-verre 180° hinge glass-glass 180° cerniera vetro-vetro 180°	8-10 mm 0°-90°-180° 90X115	20 Kg/u	zamac €U Zn *4406/032			*o	
--	----------------------------------	---------	--------------------------	--	--	----	--



*NIZA PLUS BASCULANTE 8/10 - EJE DE NYLON

BISAGRA PARED-VIDRIO charnière mur-verre hinge wall-glass cerniera parete-vetro	6-8 mm 0°-90°-180°		€U Inx *5240/00N			*o	
---	-----------------------	--	------------------	--	--	----	--



BISAGRA VIDRIO-VIDRIO 180° charnière mur-verre déplacée hinge wall-glass offset cerniera parete-vetro ala spostata	6-8 mm 0°-90°-180°		€U Inx *5241/00N			*o	
--	-----------------------	--	------------------	--	--	----	--

BISAGRAS SIN RETENCIÓN

CR. BRILLO CR. BR. CR. CR. LUC



*NIZA BASCULANTE 8/10 - EJE DE PÁSTICO EXTRA RESISTENTE

32

BISAGRA PARED-VIDRIO charnière mur-verre hinge wall-glass cerniera parete-vetro	6-8 mm 0°-90°-180°	20 Kg/u	€U Inx *4140/032	*o			
---	-----------------------	---------	------------------	----	--	--	--

BISAGRA VIDRIO-VIDRIO 180° charnière mur-verre déplacée hinge wall-glass offset cerniera parete-vetro ala spostata	6-8 mm 0°-90°-180°	20 Kg/u	€U Cu *4141/032	*o			
--	-----------------------	---------	-----------------	----	--	--	--

BISAGRA VIDRIO-VIDRIO 180° charnière mur-verre déplacée hinge wall-glass offset cerniera parete-vetro ala spostata	6-8 mm 0°-90°-180°	20 Kg/u	€U Cu *4142/032	*o			
--	-----------------------	---------	-----------------	----	--	--	--

BISAGRA VIDRIO-VIDRIO 180° charnière mur-verre déplacée hinge wall-glass offset cerniera parete-vetro ala spostata	6-8 mm 0°-90°-180°	20 Kg/u	€U Cu *4143/032	*o			
--	-----------------------	---------	-----------------	----	--	--	--

BISAGRA NIZA BASCULANTE



Plástico extra resistente con garantía de 50.000 ciclos de apertura.
Latón macizo. Acabado cromado de grado 5 (480 h.) en la prueba con niebla salina.



Bisagra basculante. Se cierra automáticamente por su propio peso. Retención a 0, 90 y 180°

Material del eje basculante:

- 10 veces más resistente de los materiales en el mercado

CR. BRILLO CR. BR. CR. CR. LUC	INOX BR. INOX POLI P.S.S. INOX LUC
---	---



*LISBOA 8/10 - P. PLEGABLES INOX 304

32 22

BISAGRA PARED-VIDRIO charnière mur-verre hinge wall-glass cerniera parete-vetro	6-8 mm 0°-90°-180°	20 Kg/u	€U Cu *4402/022			*o	
---	-----------------------	---------	-----------------	--	--	----	--



VENECIA 6/8

BISAGRA PARED-VIDRIO charnière mur-verre hinge wall-glass cerniera parete-vetro	6-8 mm 0°-90°-180°	18 Kg/u	€U Cu 4195/032	o			
---	-----------------------	---------	----------------	---	--	--	--



BISAGRA VIDRIO-VIDRIO 180° charnière mur-verre déplacée hinge wall-glass offset cerniera parete-vetro ala spostata	6-8 mm 0°-90°-180°	18 Kg/u	€U Cu 4196/032	o			
--	-----------------------	---------	----------------	---	--	--	--



MÓNACO 6/8 - TAMBIÉN PUERTA PLEGABLE

BISAGRA PARED-VIDRIO charnière mur-verre hinge wall-glass cerniera parete-vetro	6-8 mm 0°-90°-180°	18 Kg/u	REGULABLE €U Cu 1819/032	o			
---	-----------------------	---------	-----------------------------	---	--	--	--



BISAGRA VIDRIO-VIDRIO 180° charnière mur-verre déplacée hinge wall-glass offset cerniera parete-vetro ala spostata	6-8 mm 0°-90°-180°	18 Kg/u	REGULABLE €U Cu 1817/032	o			
--	-----------------------	---------	-----------------------------	---	--	--	--



*VALENCIA 6/10 , CURVO 6/8 Y JEREZ 8/10				28	32
BISAGRA VIDRIO-VIDRIO 180° charnière verre-verre 180° hinge glass-glass 180° cerniera vetro-vetro 180°	6-10 mm 20 Kg/lu 160X20 0°-90° 4XØ14 mm	€U Inx	*4316/028	*o	
HERRAJE FIJO 90° VIDRIO-VIDRIO fixation verre-verre 90° bracket glass-glass 90° morsetto vetro-vetro 90°	6-10 mm 95X95 2XØ14 mm	€U Inx	*4318/028	*o	
BISAGRA CUVO VIDRIO-VIDRIO 180° charnière "Curvo" verre-verre 180° "Curvo" hinge glass-glass 180° cerniera "Curvo" vetro-vetro 180°	8 mm 20 Kg/lu 122X40 0°-90° 3XØ14 mm	€U Cu	*4113/032	*o	APTA PARA VIDRIO CURVADO APPROPRIÉ POUR VERRE COURBÉ SUITABLE FOR CURVED GLASS IDONEA PER VETRO CURVATO
BISAGRA JEREZ VIDRIO-VIDRIO 90° charnière "Jerez" verre-verre 90° "Jerez" hinge glass-glass 90° cerniera "Jerez" vetro-vetro 90°	8-10 mm 15 Kg/lu 90X32 0°-90°	€U Cu	*4112/032	*o	

HERRAJES FIJOS



INOX 316 90X55 - PARA IBIZA				22	28
HERRAJE FIJO 90° PARED-VIDRIO ixation mur-verre 90° bracket wall-glass 90° morsetto parete-vetro 90°	8-10 mm 0°-90°-180°	316 €U Inx	4304/0..	o	o
80X50 - PARA TEIDE				ON	06 32
HERRAJE FIJO 90° PARED-VIDRIO ixation mur-verre 90° bracket wall-glass 90° morsetto parete-vetro 90°	8-10 mm 0°-90°-180°	€U Cu	4107/0..	*o	o
90X55 - PARA MALLORCA				ON	32 22
HERRAJE FIJO 90° PARED-VIDRIO ixation mur-verre 90° bracket wall-glass 90° morsetto parete-vetro 90°	8-10 mm 0°-90°-180°	€U Cu €U Inx	4106/0.. 4106/...	o o	o
45X45				ON	32 22
HERRAJE FIJO 90° PARED-VIDRIO ixation mur-verre 90° bracket wall-glass 90° morsetto parete-vetro 90°	8-10 mm 0°-90°-180°	€U Inx €U Zn	4108/022 4108/Z..	o	o
51X51				32	
HERRAJE FIJO 90° PARED-VIDRIO ixation mur-verre 90° bracket wall-glass 90° morsetto parete-vetro 90°	8-10 mm 0°-90°-180°	€U Cu	4199/032	o	
48X58 - PARA NIZA				32	
HERRAJE FIJO 90° PARED-VIDRIO ixation mur-verre 90° bracket wall-glass 90° morsetto parete-vetro 90°	8-10 mm 0°-90°-180°	€U Cu	*4144/032	*o	
90X55				32	
HERRAJE FIJO 90° PARED-VIDRIO ixation mur-verre 90° bracket wall-glass 90° morsetto parete-vetro 90°	8-10 mm 0°-90°-180°	€U Zn	*4407/032	*o	
45X50				32	
HERRAJE FIJO 90° PARED-VIDRIO ixation mur-verre 90° bracket wall-glass 90° morsetto parete-vetro 90°	8-10 mm 0°-90°-180°	€U Cu	4197/032	o	
HERRAJE FIJO 90° VIDRIO-VIDRIO ixation mur-verre 90° bracket wall-glass 90° morsetto parete-vetro 90°	8-10 mm 0°-90°-180°	€U Cu	4198/032	o	
60X50 - PARA MONACO				32	
HERRAJE FIJO 90° PARED-VIDRIO ixation mur-verre 90° bracket wall-glass 90° morsetto parete-vetro 90°	8-10 mm 0°-90°-180°	€U Cu	4105/032	o	
45X45 / 90X45				32	22
HERRAJE FIJO 90° PARED-VIDRIO ixation mur-verre 90° bracket wall-glass 90° morsetto parete-vetro 90°	8-10 mm 0°-90°-180°	€U Zn	4095/032	o	
HERRAJE FIJO 90° VIDRIO-VIDRIO ixation mur-verre 90° bracket wall-glass 90° morsetto parete-vetro 90°	8-10 mm 0°-90°-180°	€U Cu €U Inx	4096/032 *4096/022	o	*o
HERRAJE FIJO 180° VIDRIO-VIDRIO ixation mur-verre 90° bracket wall-glass 90° morsetto parete-vetro 90°	8-10 mm 0°-90°-180°	€U Cu	*4097/032	*o	
HERRAJE FIJO 3 VIDRIOS FIJOS ixation mur-verre 90° bracket wall-glass 90° morsetto parete-vetro 90°	8-10 mm 0°-90°-180°	€U Cu	4099/022		o

HERRAJES FIJOS				32
51	HERRAJE FIJO 90° PARED-VIDRIO fixation mur-verre 90° bracket wall-glass 90° morsetto parete-vetro 90°	6-8 mm 2XØ14 mm 50X50	€U Cu *4412/032	*o
90	HERRAJE FIJO 90° PARED-VIDRIO fixation mur-verre 90° bracket wall-glass 90° morsetto parete-vetro 90°	8-10 mm 2XØ16 mm 90X55	€U Cu *4417/032	*o
45	HERRAJE FIJO 90° PARED-VIDRIO fixation mur-verre 90° bracket wall-glass 90° morsetto parete-vetro 90°	6-8 mm Ø14 mm 50X45	€U Cu *4192/032	*o
45	HERRAJE FIJO 90° VIDRIO-VIDRIO fixation mur-verre 90° bracket wall-glass 90° morsetto parete-vetro 90°	6-8 mm Ø14 mm 50X450	€U Cu *4189/032	*o

PERFILES FIJOS

"U" INOX				22
	"U" INOX PULIDO U inox poli U pol.stainless steel U inox lucido	max.12mm Inx	15x15x15x1 *4375/122	o
		max.12mm Inx	15x12x15x1 *4376/122	o
		max.12mm Inx	25x15x25x1 *4377/122	o
JUNTAS PLÁSTICO - LATERAL MAMPARA				02 09
1671	JUNTAS PLÁSTICO joints en plastique plastic joints	2,1m	JUNTA VIDRIO 8MM €U 8mm Pla *1671/209	*o
1672	JUNTAS PLÁSTICO giunti in plastica	TAPA SUPERIOR Y TACOS PARED INCLUIDOS EN KIT	JUNTA VIDRIO 6MM €U 6mm Pla *1672/209	*o
"U" ALUMINIO - PARED				02
	"U" ALUMINIO PARED paroi en aluminium en « u » "u" aluminum wall parete in alluminio a "u"	8 mm	€U Al 5961/202	o
PERFIL CANNES				02 ON
	PERFIL CANNES PARED-VIDRIO profil de verre mural cannes cannes wall-glass profile profilo parete-vetro cannes	8 mm	€U Al 1673/2..	o o

BARRAS DE REFUERZO

BARRAS REFUERZO TELESCÓPICAS 90°				ON 22 28
	BARRA REFUERZO TELESCÓPICA 90° barre de renfort extensible extendable reinforcement bar barra di rinforzo estensibile	6-10 mm 70-120 cm	€U Inx 4166/0..	o o
	BARRA REFUERZO TELESCÓPICA 90° barre de renfort télescopique à 90° 90° telescopic reinforcement bar barra di rinforzo telescopica a 90°	6-10 mm 77-103 cm	€U Inx 4160/0..	o o o
BARRAS REFUERZO NO EXTENSIBLES				32 35 0B ON 22 28
	BARRA REFUERZO PARED-VIDRIO 45° barre de renfort mur-verre 45° wall-glass reinforcement bar 45° barra di rinforzo muro-vetro 45°	6-10 mm 39,3/100cm	€U Inx 4167/0.. 393 mm €U Inx 4169/022 1000 mm	o o o o
	BARRA REFUERZO REGULABLE barre de renfort réglable adjustable reinforcement bar barra di rinforzo regolabile	6-10 mm 1000 mm	€U Inx Zn 4164/0..	o o o o o
	BARRA REFUERZO VIDRIO-VIDRIO 45° barre de renfort verre-verre 45° glass-glass reinforcement bar 45° barra di rinforzo vetro-vetro 45°	6-10 mm 419 mm	€U Al 4165/032	o
REFUERZOS PARA VIDRIO				ON 22 NOVEDAD
	REFUERZO PARA VIDRIO FIJO support de garde-corps en verre glass railing bracket staffa per ringhiera in vetro	6-8 mm	5555/D.. DERECHA 5555/Z.. IZQUIERDA	o o

		PORTAESTANTE VIDRIO-VIDRIO		32	
  123/130  30 13	PORTAESTANTE VIDRIO-VIDRIO Vidrio 8-10 mm (base) / 6-8 mm (estante) TAQUET SUPPORT BRACKET Verre avec trous 8-10 mm / Verre tablette 6-8 mm FITTING FOR GLASS SHELF Glass drilled 8-10 mm / Glass shelf 6-8 mm ACCESSORIO PER MENSOLA VETRO Vetro con foro 8-10 mm / Vetro mensola 6-8 mm	 8-10 mm  6-8 mm  Ø10 mm	  4959/032	○	
	DISTANCIADOR DE SUELO	PINZA DISTANCIADOR SUELO-VIDRIO support revêtement-verre support floor-glass supporto per separazioni pavimento	 8-10 mm  123-130 mm	  * 1425/022	
	PINZA DISTANCIADOR SUELO-VIDRIO support compatibles avec ref. 1425 support compatible with ref. 1425 pinza compatibile con ref.1425	 max. 13mm	  * 1426/032	*○	
		CIERRE PARA LAVABOS		32 22	
     	CIERRE WC PARED-VIDRIO SIN MUESCA ± CONTRACERRADURA serrure wc mur-verre sans encoche + gâche lock for wc wall-glass without cut-out + strike serratura wc parete-veiro senza tacca + contro serratura	 8-10 mm 	  4138/032	○	
	CIERRE WC VIDRIO-VIDRIO SIN MUESCA ± CONTRACERRADURA serrure wc verre-verre sans encoche + gâche lock for wc glass-glass without cut-out + strike serratura wc vetro-vetro senza tacca + contro serratura	 8-10 mm 	  4137/032	○	
	CIERRE WC VIDRIO-VIDRIO ± CONTRACERRADURA serrure wc verre-verre + gâche lock for wc glass-glass + strike serratura wc vetro-vetro + contro serratura	 8-10 mm 	  4133/022		○
	CIERRE WC PICO DE LORO PARED - VIDRIO serrure a crochet wc mur-verre hook lock wc wall-glass serratura a gancio wc parete-veiro	 8-10 mm 	  4130/Z32	○	
	CIERRE WC PICO DE LORO VIDRIO - VIDRIO serrure a crochet wc verre-verre hook lock wc glass-glass serratura a gancio wc vetro-vetro + contro serratura	 8-10 mm 	  4132/Z32	○	
				  4132/Z32	○

PERIMETRALES

EJEMPLOS DE APLICACIONES

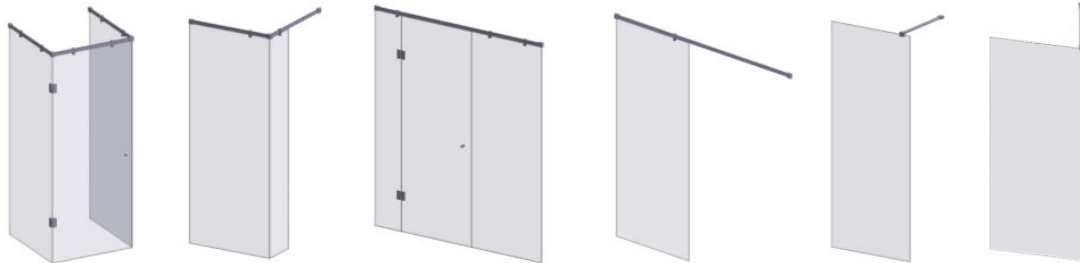

PERIMETRAL TUBO CUADRADO 19X19		22	
ANCLAJE PARED Connexion mur-verre Connexion wall-glass Aggancio parete-veetro		€/U lnx 6090/022	○
CONEXIÓN ANGULAR Connexion angle tube Corner connexion Connessione tubi		€/U lnx 6092/022	○
SOPORTE FINAL VIDRIO-TUBO AGUJERO TAPADO Support fixation tube-verre bouché Connexion tube-glass closed Aggancio tubo-veetro tappato	8-10 mm	€/U lnx 6087/022	○
SOPORTE VIDRIO-TUBO AGUJERO PASANTE Support tube-verre traversant Through-hole connexion tube-glass Aggancio tubo-veetro a foro passante	8-10 mm	€/U lnx 6091/022	○
CONEXIÓN ANGULAR 90° Connexion angle tube 90° Corner connexion 90° Connessione tubi 90°		€/U lnx 6089/022	○
SOPORTE FINAL PAR.-TUBO ARTICULADO Support fixation tube-wall Connexion tube-wall Aggancio tubo-parete	6095	€/U lnx Cu 6094/022	○
SOPORTE VIDRIO-TUBO ARTICULADO Support tube-verre Connexion tube-glass Aggancio tubo-veetro	8-10 mm 6094	€/U lnx 6095/022	○
TUBO CUADRADO DE 19X19 Tube carré 19x19 19x19 square tube Tubo quadrato 19x19	2M / 3M 19x19x1mm	€/U lnx 6093/222 6093/322	○ ○

OPCIÓN A

6090/022 + 6093 + 6087/022 BARRA DE REFUERZO -PARED 90° FIJA - A MEDIDA
Barre renfort personnalisée
Fixing rod customized
Barra di rinforzo su misura

OPCIÓN B

6094/022 + 6093 + 6095/022 BARRA DE REFUERZO - ARTICULADA - A MEDIDA
Barre renfort personnalisée
Fixing rod customized
Barra di rinforzo su misura





BARRA REFUERZO PERIMETRAL TUBO 30X10		22	
TUBO 30X10 tube 30x10 tube 30x10 tubo 30x10	6M 30X10X1,5	€/M lnx 4260/222 4260/322	○ ○
ANCLAJE CARRIL-PARED fixation mur-coulisse connexion wall-track connessione parete-guida		€/U lnx 4264/022	○
ANCLAJE TUBO-VIDRIO fixation verre-tube connexion glass-tube connessione vetro-tubo		€/U lnx * 4277/022	*○
ANCLAJE TUBO-VIDRIO fixation verre-tube connexion glass-tube connessione vetro-tubo		€/U lnx * 4279/022	*○
ANCLAJE TUBO-VIDRIO 90° fixation verre-tube 90° connexion glass-tube 90° connessione vetro-tubo 90°		€/U lnx * 4276/022	*○
ANCLAJE TUBO-VIDRIO 180° fixation verre-tube 180° connexion glass-tube 180° connessione vetro-tubo 180°		€/U lnx * 4278/022	*○
CONEXIÓN 90° CARRIL fixation coulisse 90° tracks connexion 90° connessione guide 90°		€/U lnx 4267/022	○

EJEMPLOS DE APLICACIONES



PERIMETRAL TUBO CILÍNDRICO Ø19

22

	ANCLAJE PARED Connexion mur-verre Connexion wall-glass Aggancio parete-vetro	8-10 mm Ø19 mm	€U Inx 4090/022	○	
	TUBO Ø19 tube Ø19 tubo Ø19	2M / 3M Ø19x1mm	€U Inx 4093/222 4093/322	○ ○	
	SOPORTE FINAL VIDRIO-TUBO AGUJERO TAPADO Support fixation tube-verre bouché Connexion tube-glass closed Aggancio tubo-vetro tappato	8-10 mm Ø19 mm	€U Inx 4087/022	○	
	TOPE PUERTA Butée Door stop Stop porta	8-10 mm Ø19 mm	€U Inx 4088/022	○	
	SOPORTE FINAL VIDRIO-TUBO VERTICAL (TECHO) Support fixation tube-verre vertical (plafond) Vertical connexion tube-glass (ceiling) Aggancio tubo-vetro verticale (soffitto)	8-10 mm Ø19 mm	€U Inx 4086/022	○	
	SOPORTE VIDRIO-TUBO AGUJERO PASANTE Support fixation tube-verre Connexion tube-glass Aggancio tubo-vetro	8-10 mm Ø19 mm	€U Inx 4091/022	○	
	CONEXIÓN ANGULAR Connexion angle tube Corner connexion Connessione angolare tubo	Ø19 mm	€U Inx 4092/022	○	
	CONEXIÓN ANGULAR 90° Connexion tubes 90° Connexion tubes 90° Connessione tubi 90°	Ø19 mm	€U Inx 4089/022	○	
	ANCLAJE A PARED 45° Connexion mur-verre 45° Connexion wall-glass 45° Aggancio parete-vetro 45°		€U 4085/022	○	

BARRAS REFUERZO TECHO A MEDIDA

4090/022 + 4093 + 4086/022 BARRA DE REFUERZO A MEDIDA
Barre renfort personnalisé
Fixing rod customized
Barra di rinforzo su misura



BARRAS REFUERZO PARED 90° A MEDIDA

6090/022 + 4093 + 6097/022 BARRA DE REFUERZO A MEDIDA
Barre renfort personnalisé
Fixing rod customized
Barra di rinforzo su misura



POMOS, TIRADORES Y UÑEROS





POMOS			32	35	ON	06	22	28
TIRADOR DOBLE <i>bouton double double knob pomolo doppio</i>	6-10 mm 8-10 mm Ø29mm	€U Zn 4124/Z..	○	○	○	○	○	○
TIRADOR DOBLE <i>bouton double double knob pomolo doppio</i>	6-10 mm 10 mm Ø25x32	€U Inx 1824/0..				○	○	○
TIRADOR DOBLE <i>bouton double double knob pomolo doppio</i>	6-10 mm 8 mm Ø25x25	€U Inx 4121/0..				○	○	
TIRADOR DOBLE <i>bouton double double knob pomolo doppio</i>	6-10 mm 8 mm Ø30x32	€U Zn *4123/Z..	*○		*○			
TIRADOR DOBLE <i>bouton double double knob pomolo doppio</i>	6-12 mm 10 mm Ø30x25	€U Al *4122/A..	*○		*○			
TIRADOR DOBLE <i>bouton double double knob pomolo doppio</i>	6-10 mm 12 mm Ø45x28	€U Zn 4281/00N			○			
TIRADOR DOBLE <i>bouton double double knob pomolo doppio</i>	6-10 mm 12 mm Ø45x28	€U Zn 4119/0..	○	○	*○			
TIRADOR DOBLE <i>bouton double double knob pomolo doppio</i>	6-12 mm 10 mm Ø48x43	€U Al 1584/0..	○			*○		
POMO CILÍNDRICO <i>bouton cylindrique cylindrical knob pomello cilindrico</i>	6-10 mm Ø 30mm	€U Al 5490/A0N				○		







TIRADORES			32	ON	22	28
MANILLA DOBLE <i>poignée double double door pull maniglia doppia</i>	6-10 mm 2xØ10mm CC=128mm Ø14mm	€U Inx 4127/0..			○	○
MANILLA + POMO <i>poignée + bouton door pull + knob maniglia + pomolo</i>	6-10 mm 2xØ10mm CC=128mm Ø14mm	€U Inx *4128/0..				*○
MANILLA DOBLE <i>poignée double double door pull maniglia doppia</i>	6-10 mm 2xØ6mm CC=220mm 226x34	€U Zn 4139/Z..	○		○	
MANILLA DOBLE <i>poignée double double door pull maniglia doppia</i>	6-10 mm 2xØ8mm CC=220mm 259x13	€U Al 4129/A..	○		○	
TIRADOR 20 CM <i>Poignée 20 cm Handle 20 cm Maniglia 20 cm</i>	6-8 mm 2 x Ø8mm CC=145mm 20 cm	€U Al 4114/0..	○		○	
TIRADOR 40 CM <i>Poignée 40 cm Handle 40 cm Maniglia 40 cm</i>	6-8 mm 2 x Ø8mm CC=350mm 40 cm	€U Al 5129/0..	○		○	
MANILLA + POMO <i>poignée + bouton door pull + knob maniglia + pomolo</i>	6-10 mm 2 x Ø9mm CC=190mm 205x25	€U Inx *4979/022				*○



TIRADORES TOALLEROS			32	ON	22
 MANILLA+TOALLERO poignée + serviette handle with towel bar maniglione con porta asciugano	6-12 mm 3xØ9mm CC=433mm Ø19mm	€U Inx 4131/022			○
 MANILLA+TOALLERO poignée + serviette handle with towel bar maniglione con porta asciugano	8-10 mm 2xØ8-10mm CC=450mm 25x25	€U Inx 1891/0..		○	○
 MANILLA+TOALLERO poignée + serviette handle with towel bar maniglione con porta asciugano	6-10 mm 2xØ8mm CC=440mm Ø14mm	€U Zn Inx 5960/032	○		



UÑEROS			01	ON	22	28	00
 UÑERO DOBLE ADHESIVO poignée double adhésive double adhesive pull panno doppio adesivo	 Ø60mm	€U Al Inx 4207/0..	○	○	○	○	
 GALGA MONTAJE UÑEROS gabarit de montage installation tool sagoma aiuto montaggio		€U Al 4209/000					○
 TIRADOR DOBLE bouton double double knob pomolo doppio	8-12 mm 46 mm Ø??	€U Inx 4337/0..		○		○	

TOPES



TOPES PARA PUERTA DE VIDRIO			32
 TOPE PARA PUERTA DE VIDRIO arrêt de porte en verre glass door stop fermaporta in vetro	6-8 mm	€U Cu 4953/032	○

TOALLERO



TOALLERO HORIZONTAL			32
 TOALLERO HORIZONTAL support serviette de bain single towel rail porta asciugamano a parete	50 cm	€U Al *4950/032	*○

PORTAROLLOS



TOPES PARA PUERTA DE VIDRIO			32
 PORTAROLLOS support de rouleau toilette toilet paper holder portarotolo carta igienica		€U Al *4952/032	*○

TAPAJUNTAS

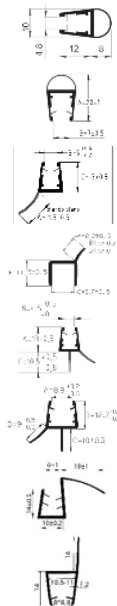

TAPAJUNTAS			09	ON		
TAPAJUNTA LATERAL BURBUJA profil étancheité lateral lateral seal giunta laterale	6-8 mm 2,2 M	€/M Pvc: 1830/10. 6-8	○	○		
	8-10 mm 2,2 M	€/M Pvc: 1833/10. 8-10	○	○		
	8-10 mm 3 M	€/M Pvc: 1833/139 8-10	○			
TAPAJUNTA INFERIOR Y LATERAL profil étancheité inferior et lateral bottom and lateral seal giunta inferiore e laterale	6-8 mm 2,2 M	€/M Pvc: 1586/109 6-8	○			
TAPAJUNTA INFERIOR Y LATERAL profil étancheité inferior et lateral bottom and lateral seal giunta inferiore e laterale	10 mm 2,2 M	€/M Pvc: 1587/109 10	○			
TAPAJUNTA INFERIOR profil étancheité inferior bottom seal giunta inferiore	6-8 mm 2,2 M	€/M Pvc: 1854/109 6-8	○			
TAPAJUNTA INFERIOR profil étancheité inferior bottom seal giunta inferiore	10-12 mm 2,2 M	€/M Pvc: 1857/109 10-12	○			
PERFIL INFERIOR profil étancheité seal giunta	8-10 mm 2,2 M	€/M Pvc: 1856/10. 8-10	○	○		
TAPAJUNTA INFERIOR Y LATERAL profil étancheité inferior et lateral bottom and lateral seal giunta inferiore e laterale	10 mm 2,2 M	€/U Pvc: *1869/209 10	*○			

TAPAJUNTAS IMANTADOS

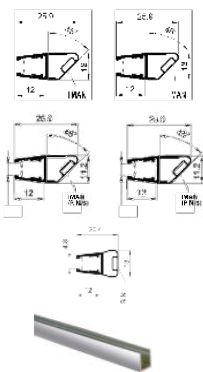

TAPAJUNTAS IMANTADOS			09	ON	02		
PERFIL CON IMÁN 90°/180° profil étancheité magnétique 90°/180° magnetic seal 90°/180° giunta magnetica 90°/180°	6-8 mm 2,2 M	€/M Pvc: *1828/109 DERECHA 6-8	*○				
		€/M Pvc: *1829/109 IZQUIERDA 6-8	*○				
CONJUNTO DE TAPAJUNTAS DER./IZQ. CON IMÁN - SET DERECHA-IZQUIERDA prof. étancheité magnet SET DROITE-GAUCHE magnetic seal SET RIGHT+LEFT giunta magnetica SET DESTRA+SINISTRA	6-8 mm 2,2 M	€/U Pvc: 1866/20. 8 MM	○	○			
		€/U Pvc: 1867/209 10 MM	○				
		€/U Pvc: 1868/209 6 MM	○				
PERFIL CON IMÁN 180° profil étancheité magnétique 180° magnetic seal 180° giunta magnetica 180°	6-8 mm 2,2 M	€/M Pvc: 1827/109 6-8	○				
PEREALUM. X TAPAJUNTAS alum. profil étancheité alum.prof.seal prof.alluminio, giunta	1,95 M Para juntas 10mm grosor	€/U Pvc: 5962/202 12,5X10X12,5			○		

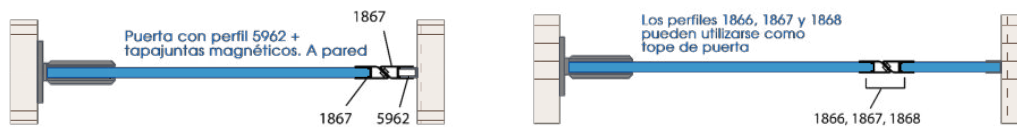

TAPAJUNTAS ADHESIVAS

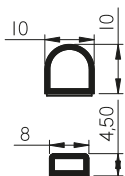

TAPAJUNTAS ADHESIVAS			09			
TAPAJUNTA ADHESIVO 2.2 M profil étancheité adhesive 2,2m adhesive seal 2,2 m giunta adesiva 2,2 m	2,2 M 10-12 mm	€/M Pvc: 1810/109 10-12 mm	○			
TAPAJUNTA ADHESIVO 2.5 M profil étancheité adhesive 2,5m adhesive seal 2,5 m giunta adesiva 2,5 m	2,5 M 8-10 mm	€/M Pvc: 1811/109 8-10 mm	○			

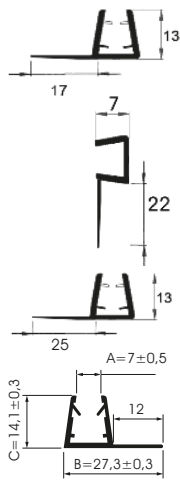

TAPAJUNTAS CORREDERA			09	ON
PERFIL LATERAL CORREDERA prof. étanchéité coulissant sliding door seal giunty porta scorrevole		€/U Pvc 1852/209 8 mm	<input type="radio"/>	
		€/U Pvc 1853/209 10 mm	<input type="radio"/>	
PERFIL LATERAL CORREDERA prof. étanchéité coulissant sliding door seal giunty porta scorrevole		€/M Pvc 1851/10.	<input type="radio"/>	
PERFIL LATERAL CORREDERA prof. étanchéité coulissant sliding door seal giunty porta scorrevole		€/U Pvc 1839/20.	<input type="radio"/>	<input type="radio"/>
PERFIL LATERAL CORREDERA prof. étanchéité coulissant sliding door seal giunty porta scorrevole		€/M Pvc 1855/109	<input type="radio"/>	

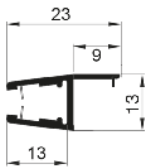

TAPAJUNTAS PLEGABLE			09
PERFIL LATERAL CON TOPE profil lateral étanchéité avec arrêt lateral seal with stop profilo laterale con arresto		€/M Pvc 1834/109	<input type="radio"/>

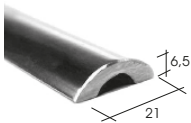

BURLETE ALUMINIO SUELO			02	ON
PERFIL BURLETE VERTIAGUAS profil seuil profile threshold profilo verticagque		€/U Al 1831/20.	<input type="radio"/>	<input type="radio"/>
	21X6,5			



BURLETE ADHESIVO PLÁSTICO SUELO			32
PERFIL BURLETE ADHESIVO VERTIAGUAS PLÁSTICO CROMADO PROFIL SEUIL ADHÉSIF Plastic chromé brillant ADHESIVE PROFILE THRESHOLD Plastic chromed PROFILO ADESIVO VERTIAGQUE Plastica finitura cromo		€/M Pvc 1832/232	<input type="radio"/>
	10X4		

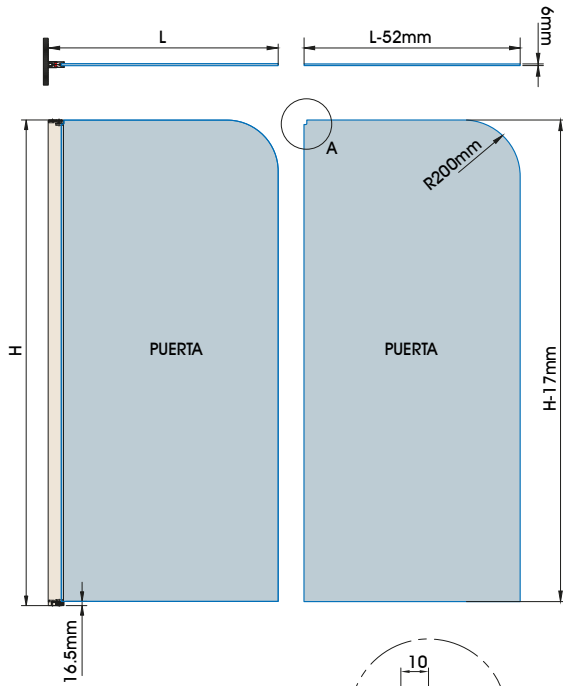

SIN FIJO

CON FIJO

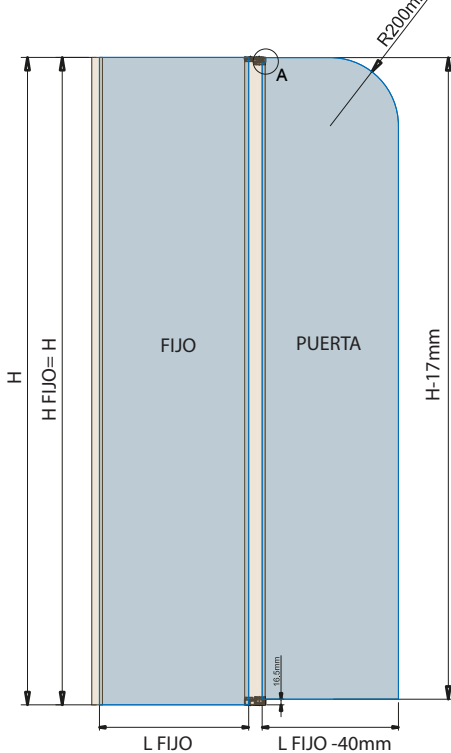
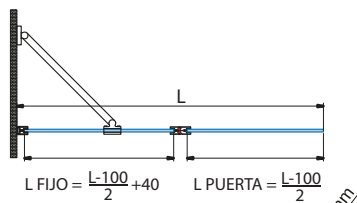

MAMPARA TIVOLI

FORMATO BAÑERA

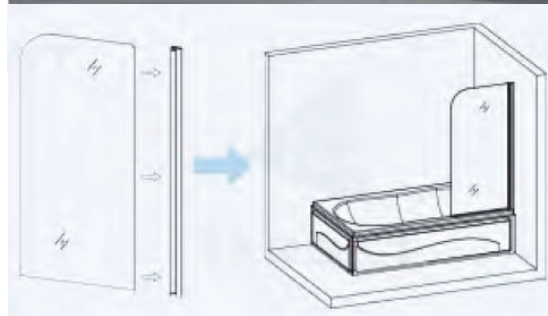

KITS

PL. BR	NEGR
ALU. BR	NOR
ALU. BR	BLACK
ALU. LUC	NERO
02	0N

KIT BAÑERA

Perfil pared bañera 145 cm
 Profilé mural pour baignoire 145 cm
 Bathtub wall profile 145 cm
 Profilo parete vasca 145 cm

6944/0.. Elu

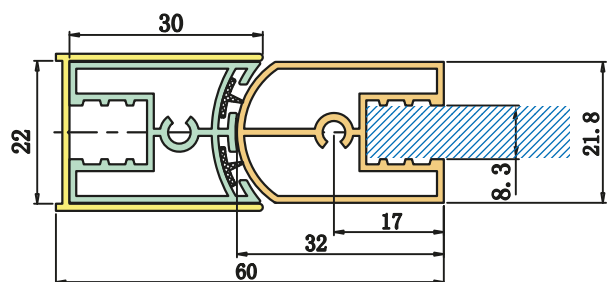

MAMPARA TIVOLI FORMATO DUCHA



MAMPARA TIVOLI FORMATO DUCHA



KITS

KITS DUCHA

Perfil pared ducha 195 cm
Profilé de paroi de douche 145 cm
Shower wall profile 145 cm
Profilo parete doccia 145 cm

6948/0..

PL. BR	NEGR
ALU. BR	NOIR
ALU. BR	BLACK
ALL. LUC	NERO
02	0N

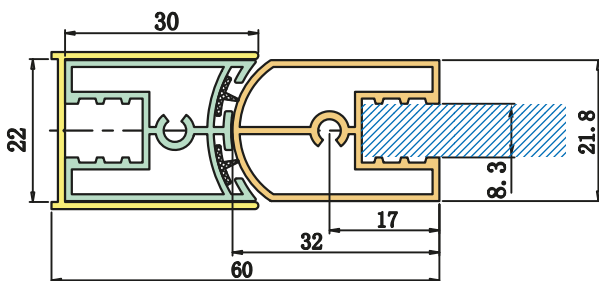

KITS

KITS DUCHA

Fijo + puerta ducha 195 cm
Fixe + porte de douche 195 cm
Fixed + shower door 195 cm
Fisso + porta doccia 195 cm

6947/0..

PL. BR	NEGR
ALU. BR	NOIR
ALU. BR	BLACK
ALL. LUC	NERO
02	0N

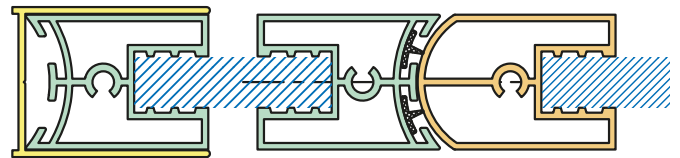

ESPECIFICACIONES

Material:
Aluminio
Acabado:
Plata brillo, negro
Aplicación:

Para bañeras o duchas
Grosor de la puerta:
6 - 8 mm /
no se requiere corte en el vidrio
Peso máximo de la puerta:

34 kg
Largo máximo de la puerta:
2100 mm
Ancho máximo de la puerta:
800 mm

* ROMA QUADRANT

PLATA, BRILLO
ALU. ANOD. BR
ALU. ANOD. BR
ALL. ANOD. LUC
02

NEGRO
NOIR
BLACK
NERO
01
PLATA, BRILLO
ALU. ANOD. BR
ALU. ANOD. BR
ALL. ANOD. LUC
02

- aluminio acabado brillo
- peso max: 30 kg/puerta
- vidrio: 6 mm

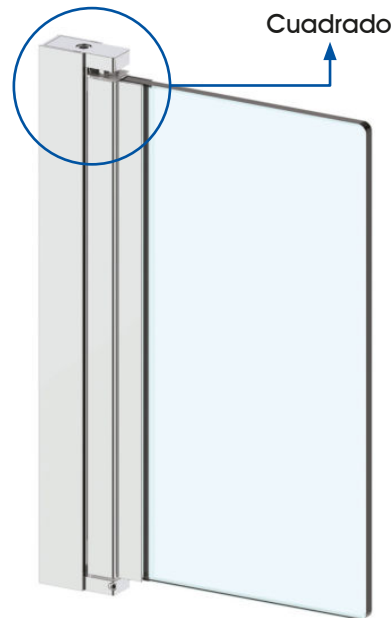

ALTO TOTAL= 1950 mm
hauteur totale, total glass, altezza totale

VIDRIO: 6 mm
verre, glass, vidrio

ALTO VIDRIO= 1903 mm
hauteur verre, high glass, altezza vetro

ANCHO MAX. = 900 mm
largeur max. = 900 mm
max. width = 900 mm
larghezza mass. = 900 mm

**CORTE NUEVO
CONSULTAR**

PUERTA VAIVÉN SIMPLE PARA PLATO DUCHA
PORTE VA-ET-VIENT SIMPLE POUR DOUCHE
SIMPLE SWINGING DOOR FOR SHOWER PLATE
PORTA VA E VIENI SEMPLICE PER PIATTO DOCCIA
VIDRIO NO INCLUIDO
VERRE NON INCLUS, GLASS NOT INCLUDED, VETRO NO INCLUSO
*4948/002 1 puerta

Al 6 mm €/u

Medidas corte vidrio ROMA QUADRANT
Consultar disponibilidad de los modelos Roma con perfil Quadrant
Vérifier la disponibilité des modèles de Rome avec le profil Quadrant
Check availability of Rome models with Quadrant profile
Verifica la disponibilità dei modelli di Roma con il profilo Quadrant

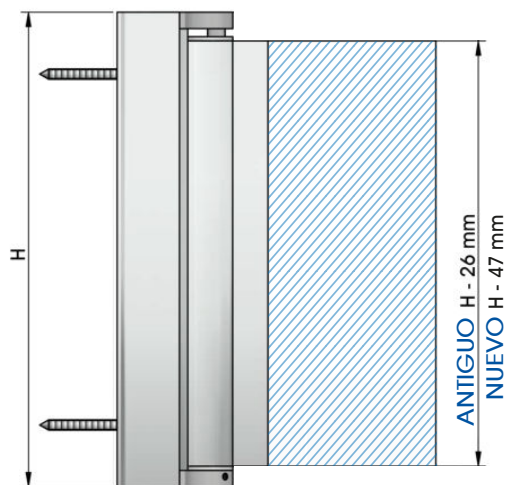

ref. 4948

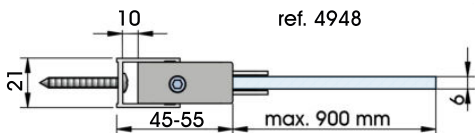

ALTO TOTAL= 1450 mm
1450 ó 1500 mm (consultar)

hauteur totale, total glass, altezza totale
VIDRIO: 6 mm
verre, glass, vidrio

ALTO VIDRIO= -26 mm
hauteur verre, high glass, altezza vetro

ANCHO MAX. = 900 mm
largeur max., max. width
larghezza mass

**CORTE ANTIGUO
CONSULTAR**

ALTO TOTAL= 1400 mm
hauteur totale, total glass, altezza totale
VIDRIO: 6 mm
verre, glass, vidrio

ALTO VIDRIO= -47 mm
hauteur verre, high glass, altezza vetro

ANCHO MAX. = 900 mm
largeur max., max. width
larghezza mass

**CORTE NUEVO
CONSULTAR**

PUERTA BATIENTE SIMPLE PARA BAÑERA
PORTE BATTANTE SIMPLE POUR BAIGNOIRE
SIMPLE SWINGING DOOR FOR BATHTUB
PORTA VA E VIENI SEMPLICE PER VASCA
VIDRIO NO INCLUIDO, VERRE NON INCLUS, GLASS NOT INCLUDED, VETRO NO INCLUSO
*4944/0..

Al 6 mm €/u

*o *o



ALTO TOTAL= 1500 mm
hauteur totale, total glass, altezza totale
VIDRIO: 6 mm
verre, glass, vidrio

ALTO VIDRIO PUERTA= 1474 mm
hauteur verre porte, high door glass,
altezza vetro porta

ALTO VIDRIO FIJO= 1500 mm
hauteur verre fixe, high fixed glass,
altezza vetro fisso

ANCHO MAX. PUERTA= 800 mm
largeur max. porte= 800 mm
max. width door = 800 mm
larghezza mass.puerta= 800 mm

ANCHO MIN. FIJO= 500 mm
largeur min. porte= 500 mm
min. width door = 500 mm
larghezza min.puerta= 500 mm

**CORTE ANTIGUO
CONSULTAR**

ALTO TOTAL= 1400 mm
hauteur totale, total glass, altezza totale
VIDRIO: 6 mm
verre, glass, vidrio

ALTO VIDRIO PUERTA= 1353 mm
hauteur verre porte, high door glass,
altezza vetro porta

ALTO VIDRIO FIJO= 1400 mm
hauteur verre fixe, high fixed glass,
altezza vetro fisso

ANCHO MAX. PUERTA= 800 mm
largeur max. porte= 800 mm
max. width door = 800 mm
larghezza mass.puerta= 800 mm

ANCHO MIN. FIJO= 600 mm
largeur min. porte= 600 mm
min. width door = 600 mm
larghezza min.puerta= 600 mm

**CORTE NUEVO
CONSULTAR**

BARRA REFUERZO 4167/032 PARED-VIDRIO 45° INCLUIDA
BARRE RENFORT 4167/032 MUR-VERRE 45° INCLUS
FIXING BAR 4167/032 WALL-GLASS 45° INCLUDED
BARRA RINFORZO 4167/032 PARETE-VETRO 45° INCLUSA

FIJO + PUERTA BATIENTE PARA BAÑERA
VERRE FIXE + PORTE BATTANTE POUR BAIGNOIRE
FIXED GLASS + SWINGING DOOR FOR BATHTUB
VETRO FISSO + PORTA VA E VIENI PER VASCA
VIDRIO NO INCLUIDO
VERRE NON INCLUS, GLASS NOT INCLUDED, VETRO NO INCLUSO
*4946/0..

Al 6 mm €/u

*o *o

ROMA



PLATA, BRILLO
ALU. ANOD. BR
ALU. ANOD. BR
ALL. ANOD. LUC
02

ALTO TOTAL= 1950 mm
hauteur totale, total glass, altezza totale

VIDRIO: 6 mm
verre, glass, vidrio

ALTO VIDRIO= 1903 mm
hauteur verre, height glass, altezza vetro

ANCHO MAX. = 900 mm
largeur max., max. width,
larghezza mass.

**CORTE NUEVO
CONSULTAR**

PUERTA VAIVÉN SIMPLE PARA PLATO DUCHA
PORTE VA-ET-VIENT SIMPLE POUR DOUCHE
SIMPLE SWINGING DOOR FOR
SHOWER PLATE
PORTA VA E VIENI SEMPLICE
PER PIATTO DOCCIA
VIDRIO NO INCLUIDO
VERRE NON INCLUS.
GLASS NOT INCLUDED. VETRO NO INCLUSO

Al €/u
6 mm

***4945/002 1 puerta *o**

Medidas corte vidrio ROMA

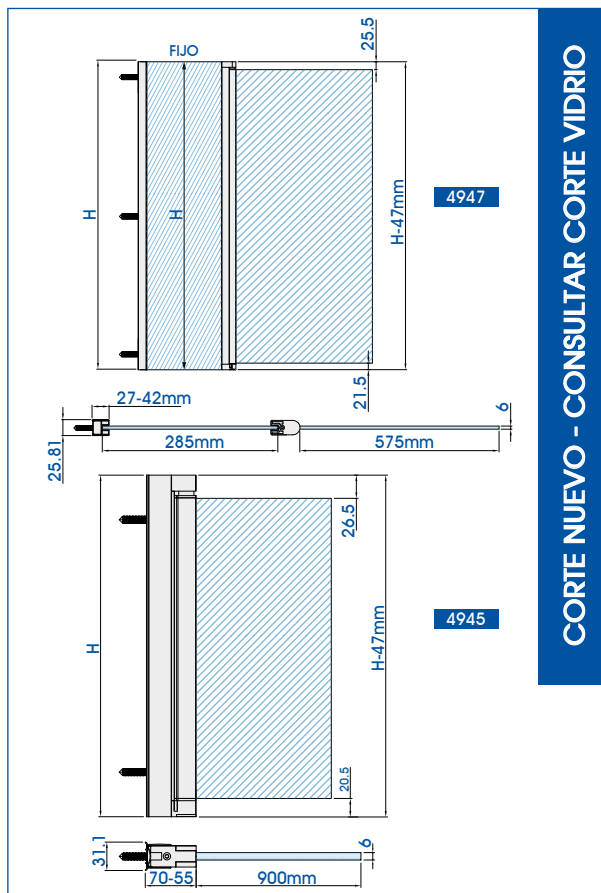

MAMPARA ARNO

NEGRO
NOR.
BLACK
NERO
0N

KITS

Al 6 mm €/u

PUERTA BATIENTE SIMPLE PARA BAÑERA
PORTE BATTANTE SIMPLE POUR BAIGNOIRE
SIMPLE SWINGING DOOR FOR BATHTUB
PORTA VA E VIENI SEMPLICE PER VASCA
VIDRIO NO INCLUIDO
VERRE NON INCLUS.
GLASS NOT INCLUDED. VETRO NO INCLUSO
***4940/00B BLANCO *o**



ALTO TOTAL= 1450 mm
hauteur totale, total glass, altezza totale

VIDRIO: 6 mm
verre, glass, vidrio
ALTO VIDRIO= 1425 mm
hauteur verre, height glass, altezza vetro

ANCHO MAX. = 800 mm
largeur max. = 800 mm
ax. width = 800 mm
larghezza mass. = 800 mm

FUJO + PUERTA BATIENTE PARA BAÑERA
VERRE FIXE + PORTE BATTANTE POUR BAIGNOIRE
FIXED GLASS + SWINGING DOOR FOR BATHTUB
VETRO FISSO + PORTA VA E VIENI PER VASCA
VIDRIO NO INCLUIDO
VERRE NON INCLUS.
GLASS NOT INCLUDED. VETRO NO INCLUSO
***4942/00B BLANCO *o**

Al 6 mm €/u



ALTO TOTAL= 1450 mm
hauteur totale, total glass, altezza totale
VIDRIO: 6 mm
verre, glass, vidrio
ALTO VIDRIO PUERTA= 1425 mm
hauteur verre porte, height door glass,
altezza vetro porta
ALTO VIDRIO FUJO= 1450 mm
hauteur verre fixe, height fixed glass, altezza
vetro fisso
ANCHO MAX. PUERTA= 800 mm
largeur max. porte= 800 mm
max. width door = 800 mm
larghezza mass. porta= 800 mm
ANCHO MIN. FUJO= 520 mm
largeur min. porte= 520 mm
min. width door = 520 mm
larghezza min. porta= 520 mm

BARRA REFUERZO PARED VIDRIO 50 cm
BARRE RENFORT MUR VERRE: 50 cm
FIXING BAR WALL-GLASS: 50 cm
BARRA RINFORZO PARETE VETRO 50 cm



cotek.

PUERTAS

KITS PUERTAS CORREDERAS

GAMA PREMIUM

**HERRAJES ALTA GAMA -
PANAMÁ AUTOMÁT. MAGNÉTICA**
KITS Y COMPONENTES

FAMILIA CANTÓN

CANTÓN VIDRIO
KITS Y COMPONENTES

CANTÓN MARCO
KITS Y COMPONENTES
DATOS GENERALES

CANTÓN MARCO INVISIBLE
KITS Y COMPONENTES

CANTÓN MARCO TELEX 2
KITS Y COMPONENTES

CANTÓN MARCO TELEX 3
KITS Y COMPONENTES
CÁLCULO MEDID. (2P/3P)
DATOS TÉCNICOS

CANTÓN MARCO TELEX MOVE
KITS Y COMPONENTES
MEDIDAS
VÍDEO DE MONTAJE
CÁLCULO MEDID. (3P/4P)

CANTÓN MARCO PIVOTANTE
ACCESORIOS P. VAYVÉN
ACCESORIOS P. BATIENTE
COMPONENTES

OTROS KITS

KOBE
KITS Y COMPONENTES

KYOTO
KITS Y COMPONENTES

SERENA
KITS Y COMPONENTES

SYNCRO
KITS Y COMPONENTES

TELEX 2
KITS Y COMPONENTES

TELEX 3
KITS Y COMPONENTES

PLATEK
KITS Y COMPONENTES

TOKYO
COMPONENTES

SHANGHAI
KITS Y COMPONENTES

PISA
KITS Y COMPONENTES

MONZA
KITS Y COMPONENTES

RIMINI
KITS
DATOS TÉCNICOS

PLEGABLE
KITS Y COMPONENTES

PLEGABLE DESPLAZADA
KITS Y COMPONENTES

APILPLUS
KITS Y COMPONENTES

PUERTA ALTA GAMA PANAMÁ AUTOMÁTICA MAGNÉTICA

MOTOR ELECTROIMANES / Discreto, ultrasilencioso, sin mantenimiento.

Aluminio anodizado	Ancho máximo 100 cm	40 kg/ puerta	Testado 500.000 ciclos
P. Vidrio 8-10 mm	P. Enmarcadas 45 mm	P. Madera ≤45 mm	Puerta vidrio

INFORMACIÓN GENERAL

- Uso interior; doméstico, oficinas, hoteles, clínicas médicas, etc.
- Fácil instalación,
- Frecuencia de paso media/baja.

KITS

NEGRO
NOIR
BLACK
NERO
ON



KIT TÁCTIL

- 80-100 cm **4080/31N**
- 100-120 cm **4080/32N**
- 120-140 cm **4080/34N**



KIT SENSORES DE DISTANCIA

- 80-100 cm **4081/31N**
- 100-120 cm **4081/32N**
- 120-140 cm **4081/34N**



KIT INFRARROJO

- 80-100 cm **4082/31N**
- 100-120 cm **4082/32N**
- 120-140 cm **4082/34N**

Cada kit contiene dos piezas de el modo de apertura elegido.

SOBRE PEDIDO se puede conseguir puertas eléctricas telescópicas y/o sincronizadas.

MÚLTIPLES MODOS DE APERTURA PARA ELEGIR:



INTERRUPTOR DE SENSORES DE DISTANCIA



INTERRUPTOR DE INFRARROJO



INTERRUPTOR TÁCTIL



SOBRE PEDIDO
INTERRUPTOR DE HUELLAS DACTILARES



SOBRE PEDIDO
INTERRUPTOR FACE ID

MONTAJE DEL CARRIL

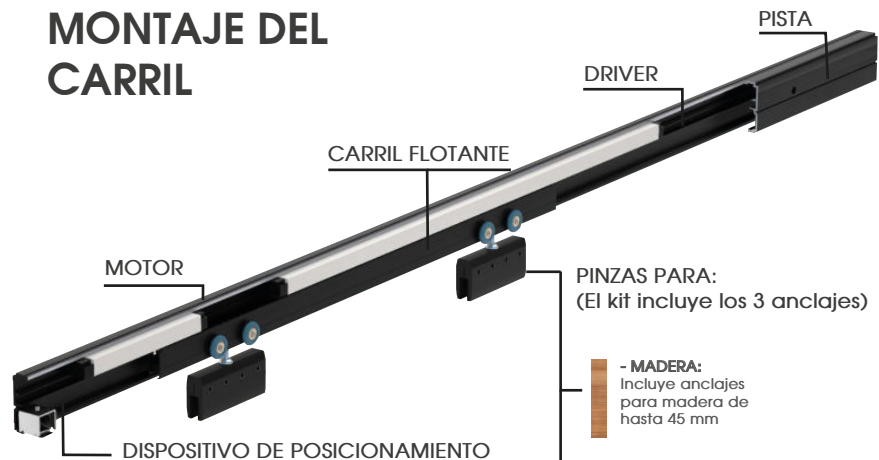

PINZAS PARA: (El kit incluye los 3 anclajes)

- **MADERA:**
Incluye anclajes para madera de hasta 45 mm

- **PUERTAS ENMARCADAS:**
Incluye anclajes para puerta Canton Marco.

- **VIDRIO:**
Incluye anclajes para vidrios de 8-10 mm

TESTADO 500.000 CICLOS

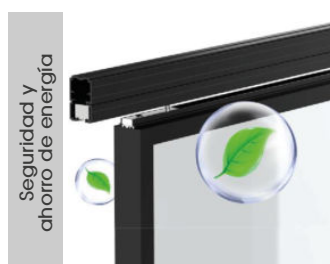
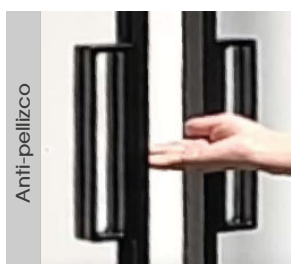

MONTAJE SISTEMA A PARED / A TECHO: (VIDRIO / VIDRIO ENMARCADO / MADERA)

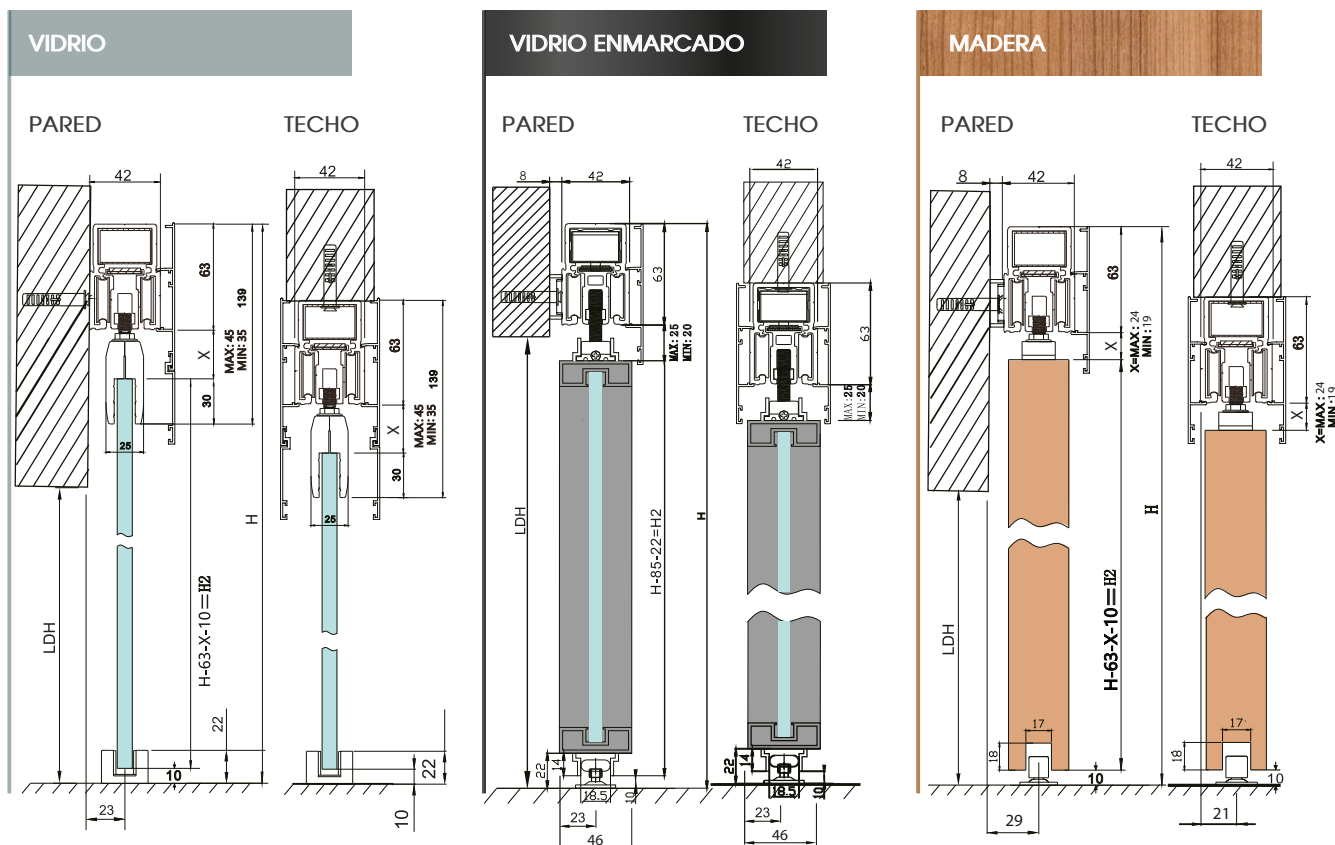

DISTINTOS
MODOS DE
APERTURA
Propuesta en
la imagen:
interruptor
táctil

* Escoger el carril magnético dependiendo del ancho de la puerta

Ancho de puerta	Ancho carril	Ref.
≤ 1000mm	793mm	4080/31N
1000-1200mm	1033mm	4080/32N
1200-1400mm	1240mm	4080/34N

CARACTERÍSTICAS DEL PRODUCTO

- Ajuste de altura 5mm
- Ruido ≤ 40dB
- Standby consumo ≤ 5w
- Consumo ≤ 100w
- Velocidad cierre 200-500 mm/sec
- Tensión 220v/110v
- Certificaciones:

CE EMC LVD FC

FAMILIA CANTON

CANTÓN VIDRIO

1P.CORREDERA 180°



1P.CORREDERA + FIJO 180°



Peso máximo: 80 Kg/Puerta
Vidrio templado y o laminado: 8mm

(KITS CON O SIN TAPA OPCIONAL)

CANTÓN MADERA

1P.CORREDERA 180° PARED



Peso máximo: 80 Kg/Puerta
Vidrio templado y o laminado: 8mm

(KITS CON O SIN TAPA OPCIONAL)

CANTÓN MARCO / (Con/Sin p.JAPONESA)

1P.CORREDERA 180°



1P.CORREDERA + FIJO 180°



2P.CORREDERAS 180°



Peso máximo: 80 Kg/Puerta
Vidrio templado y o laminado: 8mm

CANTÓN MARCO INVISIBLE VIDRIO
(Con/Sin p.JAPONESA)

1P.CORREDERA 180° PARED



CANTÓN MARCO INVISIBLE MADERA

1P.CORREDERA 180° PARED



Peso máximo: 60 Kg/Puerta
Vidrio templado y o laminado: 8mm

CANTÓN MARCO TELEX VIDRIO O MADERA / (Con/Sin p.JAPONESA)

**2P.TElescÓPICAS
180°**



**2P.TElescÓPICAS
+ FIJO 180°**



**3P.TElescÓPICA
180°**



**3P.TElescÓPICAS
+ FIJO 180°**

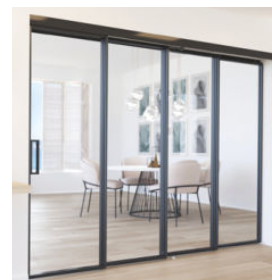

Peso máximo: 80 Kg/Puerta
Vidrio templado y o laminado: 8mm

**(KITS CON VIDRIO ENMARCADO O CON MADERA.
VIDRIO Y MADERA NO INCLUIDOS)**

CANTÓN MARCO TELEX MOVE/ (Con/Sin p.JAPONESA)

**3P.TElescÓPICAS 180°
MÓVILES - 2 LADOS**



**4P.TElescÓPICAS 180°
MÓVILES - 2 LADOS**

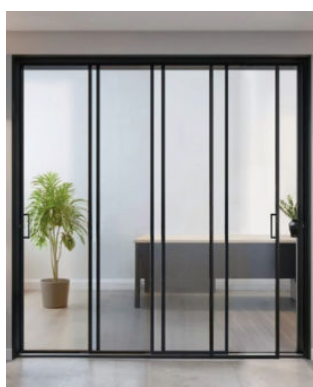

**Peso máximo:
80 Kg/Puerta**
**Vidrio templado
y o laminado: 8mm**

CANTÓN MARCO PIVOTANTE

**P.BATIENTE VAYVEN
- "DORMA" Y F.AIRE**



**P.BATIENTE
- BISAGRAS**



**Peso máximo:
40-80 Kg/Puerta**
**Vidrio templado
y o laminado: 8mm**

CANTÓN VIDRIO

PUERTA CORREDERA DE VIDRIO

- peso max. puerta: 80 kg/puerta
- vidrio 8-10 mm
- ancho min. vidrio 600 mm
- sin muesca en el vidrio
- con amortiguador y autocierre
- pods-limite porte: 80 kg/porte
- verre 8-10 mm
- largeur minimale verre 600 mm
- sans encoches
- avec amortisseur et fermeture automatique

- weight max. door: 80 kg/door
- glass 8-10 mm
- min. wide glass 600 mm
- without cut-out
- buffer and sel-closing system
- peso max. porta: 80 kg/porta
- vetro 8-10 mm
- larghezza min. vetro 600 mm
- senza tacca nel vetro
- ammortizzatore e autochiusura

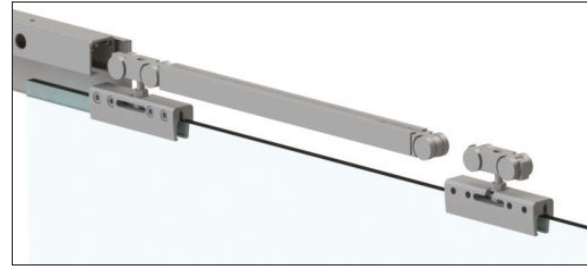

SECCIÓN PARA PUERTAS DE VIDRIO

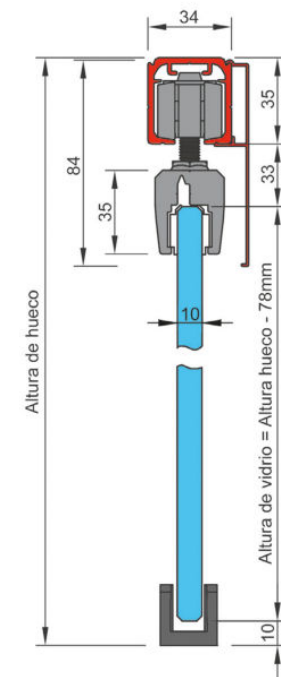
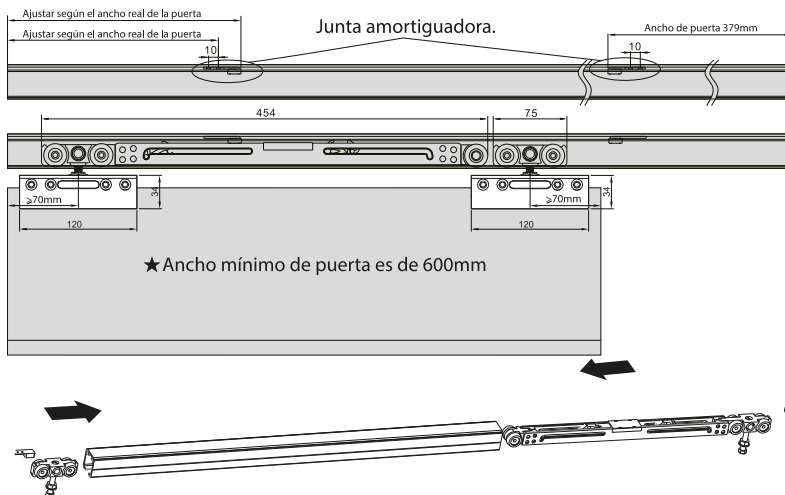
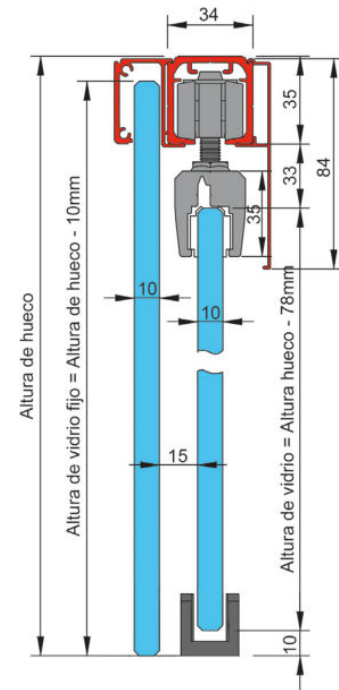

MONTAJE A TECHO O PARED

EL CARRIL 5111 ESTÁ MECANIZADO CON UN TALADRO CADA 25 CM PARA SER FIJADO DIRECTAMENTE A LA PARED SIN NECESIDAD DE ESCUADRAS

- Montage au plafond ou au muret. Le profilé supérieur 5111 est usiné avec des trous tous les 25 cm pour être fixé directement au mur sans avoir besoin de supports.
- Ceiling or wall mount. the track 5111 is machined with holes every 25 cm to be fixed directly to the wall without the need for brackets
- Montaggio a soffitto o a muro. La guida superiore 5111 è meccanizzata con fori ogni 25 cm per essere fissata alla parete senza necessità di supporti

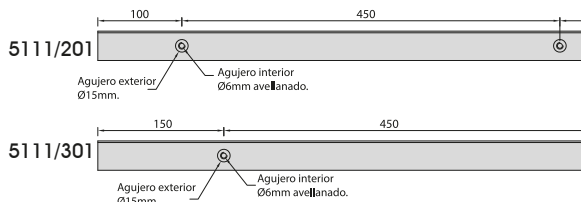



CARRIL
PROFIL SUPÉRIEUR
UPPER TRACK
GUIDA SUPERIORE
5111/201 2 m
5111/301 3 m



PERFIL CARRIL FIJO
PROFIL FIXE
FIXED RAIL PROFILE
PROFILO BINARIO FISSO
5114/201 2 m
5114/301 3 m

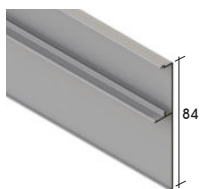

PERFIL TAPA CARRIL
PROFIL COUVERTURE
TRACK COVER PROFIL
PROFILO COPERTINA GUIDA
5112/201 2 m
5112/301 3 m

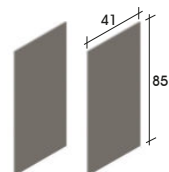

TAPA LATERAL DE CARRIL
COUVERTURE LATÉRALE DU PROFIL
TOP RAIL SIDE COVER
COPERTURA LATÉRALE SUPERIORE
5113/001 SET 2U.



KIT PINZA PORTAVIDRIO
KIT PINCE POUR VERRE
KIT CLAMP FOR GLASS
KIT PINZA PER VETRO
5110/001 CON BUFFER

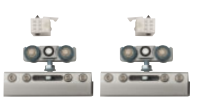

COJINETES PARA 1 PUERTA
ROULEMENTS POUR 1 PORTE
FITTINGS FOR 1 DOOR
CUSCINETTI PER 1 ANTE
5125/000 SIN BUFFER



GALGA MONTAJE UÑEROS
GABARIT DE MONTAGE
INSTALLATION TOOL
SAGOMA AIUTO MONTAGGIO
4209/000



POMO
POIGNÉE
KNOB
POMO
4223/0..



UÑERO DOBLE ADHESIVO
POIGNÉE DOUBLE ADHESIVE
DOUBLE ADHESIVE PULL
POMO DOPPIO ADHESIVO
4207/001
4207/0..

CP. BILLO C.R. POLI BR. C.R. CR. LUC.	PL. M ALU. M ALL. NAT	BRUTO BRUT RAW GREZZO	PLÁSTICO PLASTICI E PLASTIC C PLASTICA
32	01	00	09

Al	2/3 m		€/u
----	-------	--	-----

Al	2/3 m	∞ 5111	€/u
----	-------	--------	-----

Al	2/3 m	∞ 5111	€/u
----	-------	--------	-----

Al		∞ 5112	€/u
----	--	--------	-----

Al Fe	8-10 mm	€/u
-------	---------	-----

80 kg/set		
-----------	--	--

Al Fe	8-10 mm	€/u
-------	---------	-----

80 kg/set		
-----------	--	--

Al		€/u
----	--	-----

Al	100	€/u
----	-----	-----

8-10 mm		
---------	--	--

Ø 60		€/u
------	--	-----

INOX BR INOX POLI P.S.S INOX LUC	INOX SAT. INOX SAT. S.S.S INOX SAT.	NEGRO INOR BLACK NERO
22	28	0N

Al			
inox			
s.s.			

KITS

PLATA MATE
ALU. MATT
ALL. NATURALE
01

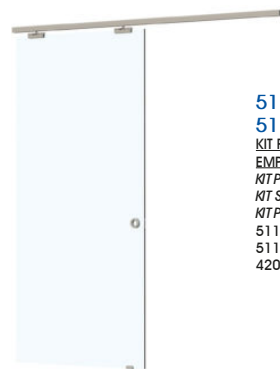

**1 PUERTA
CORREDERA**

5118/E21 2 m
5118/E31 3 m

KIT PUERTA CORREDERA PARA CRISTAL
EMPOTRABLE EN EL TECHO

KIT PORTE COUSSANTE VERRE AU PLAFOND
KIT SLIDINGDOOR RECESSED IN THE CEILING
KIT PORTA SCORREVOLE INCASSATA NEL SOFFITTO

5111/201-5111/301 1 u. carril
5110/001 1 u. set pinzas portavidrio
4207/001 1 u. uñero

Incluye guidador de suelo



**1 PUERTA
CORREDERA**

5119/P21 2 m
5119/P31 3 m

KIT PUERTA CORREDERA DE CRISTAL A PARED
KIT DE PORTE COUSSANTE FIXÉE A MUR

KIT SLIDINGDOOR FIXED TO THE WALL
KIT PORTA SCORREVOLE FISSATA A PARETE

5111/201-5111/301 1 u. carril
5112/201-5112/301 1 u. tapa carril
5113/001 1 u. set tapas lateral carril
5110/001 1 u. set pinzas portavidrio
4207/001 1 u. uñero

Incluye guidador de suelo

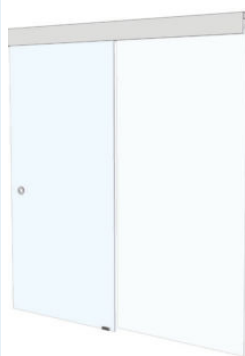

**1 PUERTA +
FIJO**

5126/T21 2 m
5126/T31 3 m

KIT PUERTA CORREDERA DE CRISTAL CON VIDRIO FIJO
KIT PORTE COUSSANTE EN VERRE AVEC VITRE FIXE

SLIDING GLASS DOOR KIT WITH FIXED GLASS
KIT PORTA SCORREVOLE IN VETRO CON VETROFISSO

5111/201-5111/301 1 u. carril
5114/201-5114/301 1 u. carril fijo
5112/201-5112/301 2 u. tapa carril
5113/001 1 u. set tapas lateral carril
5110/001 1 u. set pinzas portavidrio
4207/001 1 u. uñero

Incluye guidador de suelo

CANTÓN MARCO

PUERTA CORREDERA
DE VIDRIO ENMARCADO

KITS

BLANCO BLANC WHITE BIANCO	NEGRO NOR BLACK NERO	BRUTO BRUT RAW GREZZO	COLOR COULEUR COLOR COLORE
OB	ON	OO	OP

1 PUERTA
CORREDERA

ANCHO PUERTA
HASTA 95
CARRIL 2M

REF. 5150/00.

X1	5111/20.
X1	5210/20.
X1	5122/00N
X1	5204/00.
X1	5208/00.
X5	5124/00N
X1	5123/00N

ANCHO PUERTA
MÁS DE 95
CARRIL 3M

REF. 5150/01.

X1	5111/30.
X1	5210/30.
X1	5122/00N
X1	5204/01.
X1	5208/00.
X7	5124/00N
X1	5123/00N

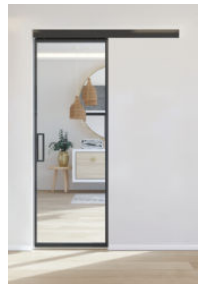

5150/00.	<input type="radio"/>	<input type="radio"/>	<input type="radio"/>	<input type="radio"/>
5150/01.	<input type="radio"/>	<input type="radio"/>	<input type="radio"/>	<input type="radio"/>

1 FIJO + 1 PUERTA
CORREDERA

ANCHO PUERTA
HASTA 95
CARRIL 2M

REF. 5151/00.

X2	5111/20.
X2	5210/20.
X1	5122/00N
X2	5204/00.
X1	5208/00.
X1	5203/00.

ANCHO PUERTA
MÁS DE 95
CARRIL 3M

REF. 5151/01.

X2	5111/30.
X2	5210/30.
X1	5122/00N
X2	5204/01.
X1	5208/00.
X1	5203/00.



5151/00.	<input type="radio"/>	<input type="radio"/>	<input type="radio"/>	<input type="radio"/>
5151/01.	<input type="radio"/>	<input type="radio"/>	<input type="radio"/>	<input type="radio"/>

2 PUERTAS
CORREDERAS

ANCHO PUERTA
HASTA 95
CARRIL 2M

REF. 5152/00.

X2	5111/20.
X2	5210/20.
X2	5122/00N
X2	5204/00.
X2	5208/00.

ANCHO PUERTA
MÁS DE 95
CARRIL 3M

REF. 5152/01.

X2	5111/30.
X2	5210/30.
X2	5122/00N
X2	5204/01.
X2	5208/00.



5152/00.	<input type="radio"/>	<input type="radio"/>	<input type="radio"/>	<input type="radio"/>
5152/01.	<input type="radio"/>	<input type="radio"/>	<input type="radio"/>	<input type="radio"/>

COMPONENTES
CARRIL

BLANCO BLANC WHITE BIANCO	NEGRO NOR BLACK NERO	BRUTO BRUT RAW GREZZO	COLOR COULEUR COLOR COLORE
OB	ON	OO	OP

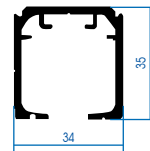

CARRIL SUPERIOR
RAIL EN ALUMINIUM
ALUMINIUM RAIL
BINARIO IN ALLUMINIO
5111/20. 2M
5111/30. 3M
5111/40. 4M

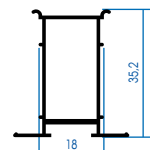

PERFIL ENTRE CARRILES
PROFIL ENTRE RAILS
PROFILE BETWEEN RAILS
PROFILO TRA BINARI
5128/20. 2M
5128/30. 3M
5128/40. 4M

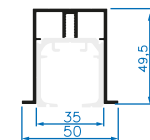

PERFIL PARA EMPOTRAR A TECHO
PROFIL POUR MONTAGE AU PLAFOND
PROFILE FOR CEILING MOUNTING
PROFILO PER MONTAGGIO A SOFFITTO

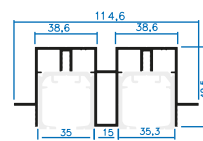

1 CARRIL/1 RAIL /1 BINARI
5450/10. 1M
2 CARRIL/2 RAIL /2 BINARI
5451/10. 1M

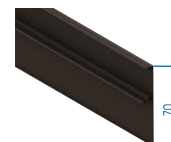

TAPA DE CARRIL SUPERIOR
COUVERTURE DE RAIL
SUPÉRIEURE
TOP RAIL COVER
COPERTURA SUPERIORE DEL
BINARIO
5210/20. 2M
5210/30. 3M
5210/40. 4M

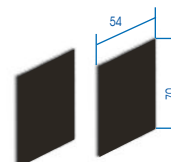

TAPA LATERAL
X
ENDCAP
Y
5123/00. SET 2 U.

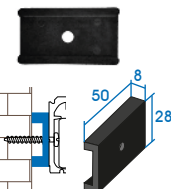

SEPARADOR DE PARED
SÉPARATEUR MURAL
WALL SPACER
Distanziatore
5124/00N

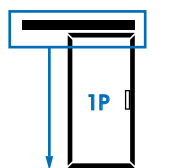

SET COJINETES PARA 1 PUERTA
JEU DE ROULEMENTS POUR 1 PORTE
SET OF FITTINGS FOR 1 DOOR
SET CUSCINETTI PER 1 ANTE
5122/00N selfclosing

G x1 COJINETE PEQUEÑO SIN RUEDITA
(carro y cojinete pequeño)

D x1 BUFER (bufer y cojinete pequeño)

E x2 FRENOS TIPO BUFER M x1 GUIADOR DE SUELO

COMPONENTES MARCO

BLANCO BLANC WHITE BIANCO	NEGRO NOIR BLACK NERO	BRUTO BRUT RAW GREZZO	COLOR COULEUR COLOR COLORE
0B	0N	00	0P

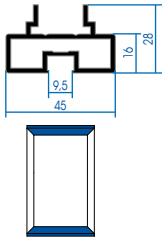

PERFIL INTERIOR Y SUPERIOR (MARCO)
PROFIL DE CADRE SUPÉRIEUR ET INFÉRIEUR
UPPER AND BOTTOM
FRAME PROFILE
PROFILO SUPERIORE E
INFERIORE CORNICE
5205/20.

Al	2M	€/u
----	----	-----

○ ○ ○ ○

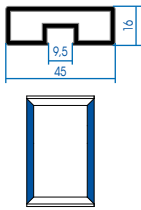

PERFIL LATERAL (MARCO)
PROFIL DE CADRE LATÉRAL
LATERAL FRAME PROFILE
PROFILO LATERALE CORNICE
5206/30.

Al	3M	€/u
----	----	-----

○ ○ ○ ○



ESQUADRA UNIÓN PERFILES
SUPPORT POUR ASSEMBLER DES PROFILS
BRACKET FOR JOINING PROFILES
GIUNTO UNIONE PROFILI
5207/000

Al	€/u
----	-----

○ PLÁSTICO
PLASTIQUE
PLASTIC
PLASTICA
09



GALGA ESCUADRA / MECANIZACIÓN PERFIL
JAUGE CARRÉE
BRACKET GAUGE
CALIBRO SQUADRA
5207/010

Pla	€/u
-----	-----

○



CINTA ADHESIVA VIDRIO
RUBAN ADHÉSIF DOUBLE FACE EN VERRE
GLASS DOUBLE SIDED TAPE
NASTRO BIADESIVO VETRO
5209/109
5209/009 ROLLO DE 33M

Pla	€/m
-----	-----

○

○



KIT MARCO DE ALUMINIO 3X1M (1 PUERTA)
KIT CADRE DE ALUMINIUM
3X1M (1 PORTÉ)
SET ALUMINIUM FRAME
3X1M (1 FRAME)
CONGIUNTO PERIMETRALE
DI ALLUMINIO 3X1M
5204/00. ancho hasta
95cm
5204/01. ancho más
de 95cm

Al	3M	€/u
----	----	-----

○ ○ ○ ○

N x2



O x2

P x4



N Perfil interior y superior (marco)

O Perfil lateral (marco)
P Esquadra unión perfiles

Q x1



Q Cinta adhesiva vidrio



COMPONENTES ACCESORIOS

BLANCO BLANC WHITE BIANCO	NEGRO NOIR BLACK NERO	BRUTO BRUT RAW GREZZO	COLOR COULEUR COLOR COLORE
0B	0N	00	0P



TIRADOR DOBLE PARA MARCO DE ALUMINIO
POIGNÉE DOUBLE POUR CADRE EN ALUMINIUM
DOUBLE HANDLE FOR
ALUMINIUM FRAME
MANIGLIA DOPPIA
TELAIO IN ALLUMINIO
5208/00.

Al	213x46x13mm	€/u
----	-------------	-----

○ ○ ○ ○



TIRADOR DOBLE CON PESTILLO PICO DE LORO
DOUBLE POIGNÉE DE VERROUILLAGE
DOUBLE HANDLE WITH LATCH
MANIGLIA DOPPIA CON CHIAVISTELLO
5216/00N

Al	213x46x13mm	€/u
----	-------------	-----

○



CERRADURA DE PUERTA ENMARCADA CON LLAVE PICO DE LORO
SERRURE DE PORTE ENCADRÉE AVEC CLÉ
FRAMED DOOR LOCK WITH KEY
SERRATURA PER PORTE CON
CORNICE CON CHIAVE
5215/00N

Al	104x77x15mm	€/u
----	-------------	-----

○



ANCLAJE PARA MARCO DE PUERTA FIJA
ANCRAGE DE CADRE DE PORTE FIXE
FIXED DOOR FRAME ANCHOR
ANCORAGGIO TELAILO PORTA FISSO
5203/000

Ix	€/u
----	-----

○

Al	3M	15,6x10,1mm	€/u
----	----	-------------	-----

Ⓞ 5209/109



PERFIL ALUMINIO PARA CRISTAL-PUERTA DE PANEL JAPONÉS
PROFILÉ EN ALUMINIUM POUR LE VERRE DANS LA PORTE À
PANNEAU JAPONAIS.
ALUMINIUM PROFILE FOR GLASS IN JAPANESE PANEL DOOR.
PROFILO IN ALLUMINIO PER
VETRO IN ANTA A
PANNELLO GIAPPONESE.
5127/30.

○ ○ ○ ○

Instrucciones de montaje en la página 11.



PERFIL INTERIOR Y SUPERIOR (MARCO)
PROFILÉ DE FINITION "L"
"L" FINISHING PROFILE
PROFILO DI FINITURA A "L"
5202/10.

Al	2M	40x10x0,8mm	€/m
----	----	-------------	-----

○ ○ ○ ○

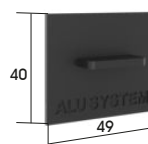

TAPETA EMBELLECEDORA
PROFILÉ DE FINITION "L"
"L" FINISHING PROFILE
PROFILO DI FINITURA A "L"
85205/00N

Pl	40x10x0,8mm	€/u
----	-------------	-----

○

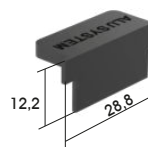

TAPETA EMBELLECEDORA
PROFILÉ DE FINITION "L"
"L" FINISHING PROFILE
PROFILO DI FINITURA A "L"
85203/00N

Pl	40x10x0,8mm	€/u
----	-------------	-----

○

POSIBLES APLICACIONES

MARCO 1

1 PUERTA CORREDERA



A ALINEADO
EN PARKING

B TIRADOR
SALIENTE

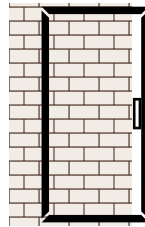
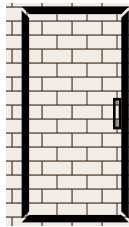

MARCO 2

2 PUERTAS CORREDERAS



ABIERTO

CERRADO

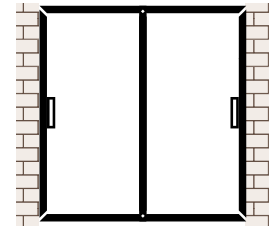
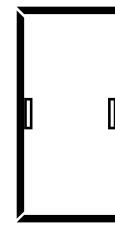

1 FIJO + 1 PUERTA CORREDERA



A ALINEADO
EN PARKING

B TIRADOR
SALIENTE

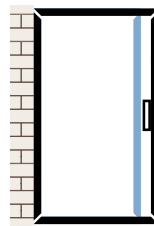
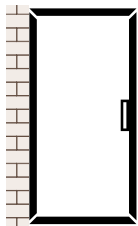

DATOS GENERALES

ACABADOS



Puerta de vidrio y marco de aluminio/
Marco disponible en bruto para pintar en cualquier RAL.

+ VIDRIO



Vidrio de 8 mm

* Para otros acabados, consultar pedido mínimo y plazo de entrega.

PESO



80 Kg max por hoja

CARACTERÍSTICAS

Deslizamiento suave
Soft-closing en apertura y cierre
Diferentes posibilidades.
Posibilidad de crear una estructura japonesa personalizada.

ANCLAJE

ANCLAJE TECHO

Instalación a techo
Ceiling mounted

ANCLAJE PARED

Instalación a pared
Wall mounted

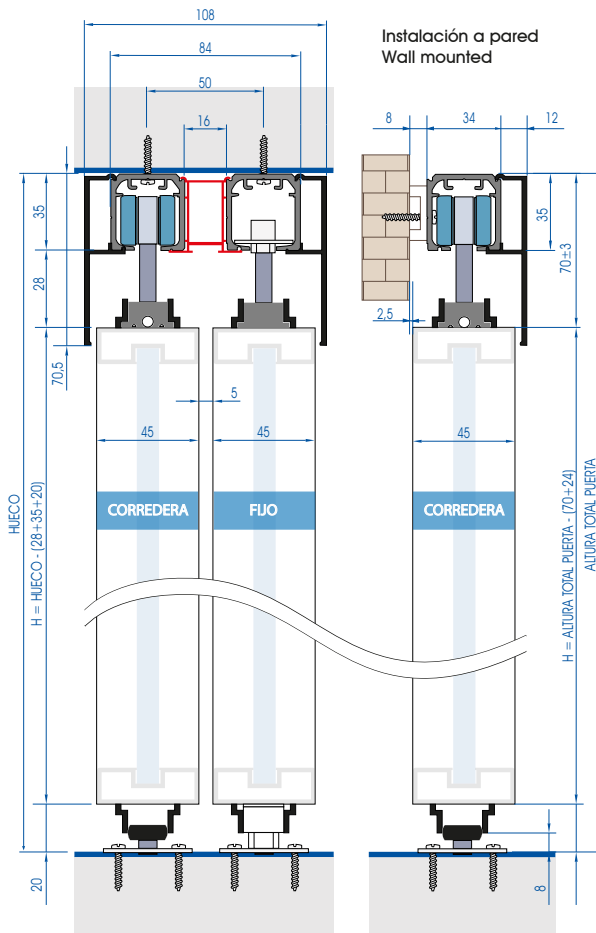

SECCIONES PERFILES

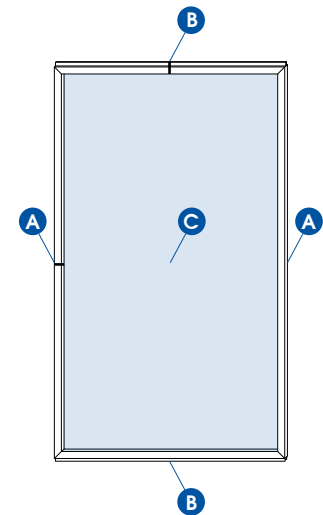
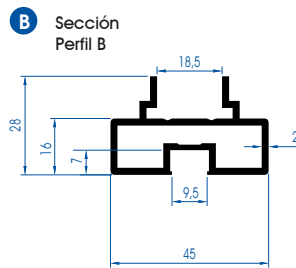
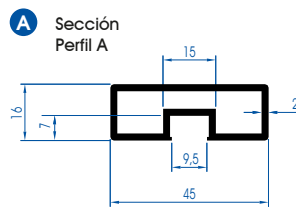

MEDIDAS VIDRIO

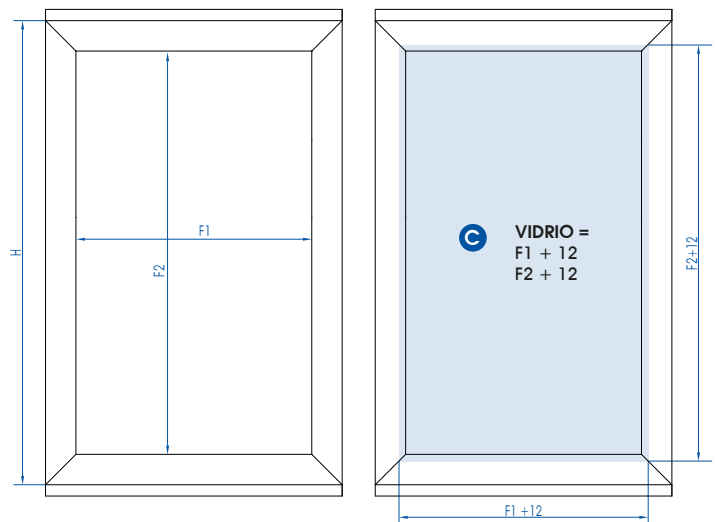

CANTÓN MARCO INVISIBLE

PUERTA CORREDERA
CON MECANISMO OCULTO

Metodo de
instalación 1:

Puerta centrada
con el hueco

- La puerta no se abre el ancho del hueco completo, con el herraje no queda alineada con la pared por completo.
Ver dibujo:
PUERTA ABIERTA

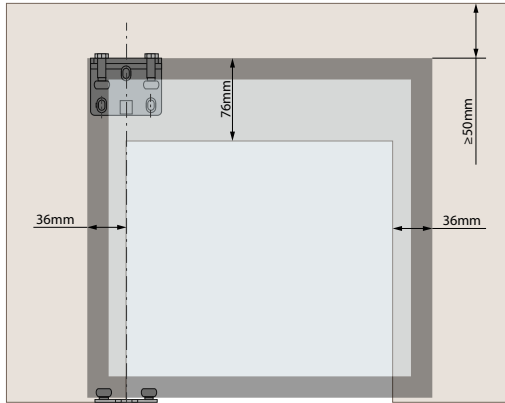

PUERTA
CERRADA



PUERTA ABIERTA

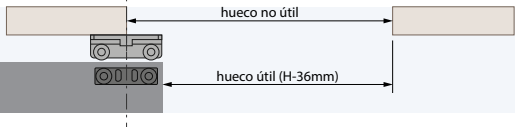

Metodo de
instalación 2:

Puerta tocando la
pared en uno de
los lados

-La puerta se abre el ancho completo del hueco. Todo el hueco es útil.
Ver dibujo:
PUERTA ABIERTA

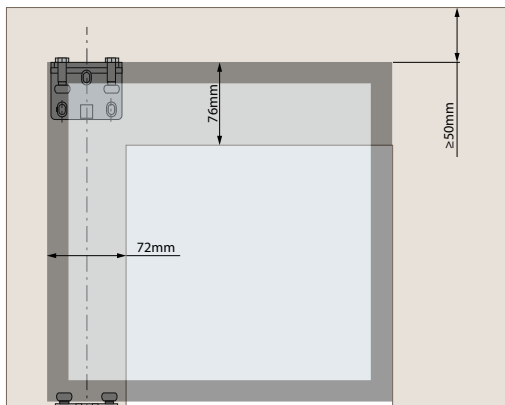

PUERTA
CERRADA

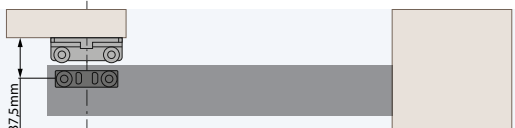

PUERTA ABIERTA

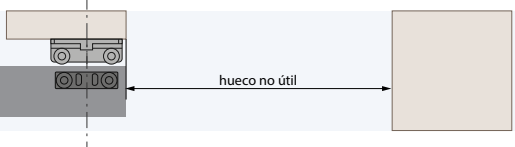

MEDIDAS VIDRIO

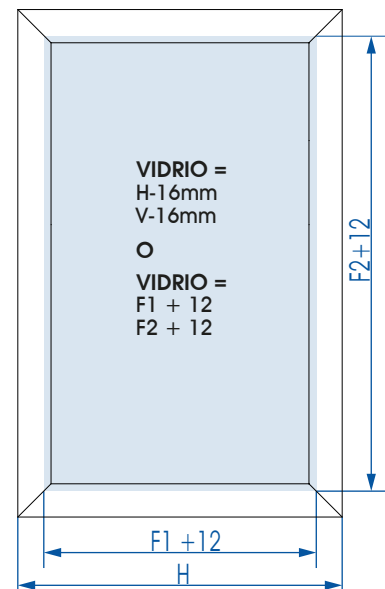
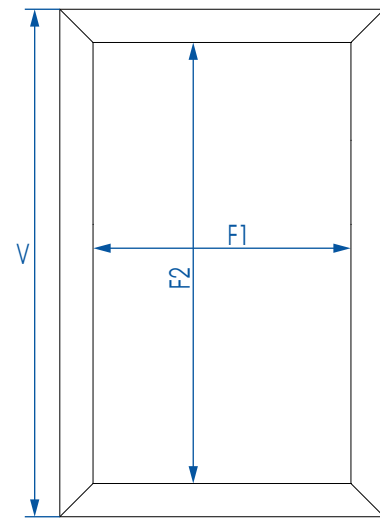

KIT COJINETES

NEGRO
NOR
BLACK
NERO
ON

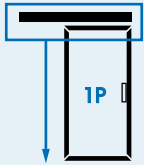

KIT COJINETES Y GUÍAS PARA 1 PUERTA
JEU DE ROULEMENTS POUR 1 PORTE
SET OF FITTINGS FOR 1 DOOR
SET CUSCINETTI PER 1 ANTE
5230/00N selfclosing

€/u

o

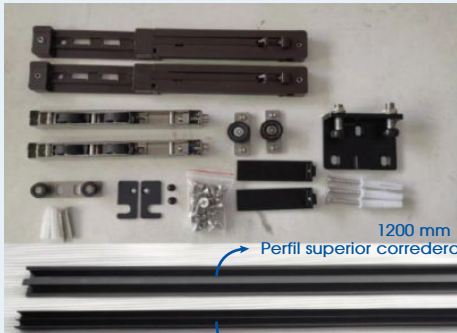

1200 mm

Perfil superior corredera

Perfil inferior puerta
1200 mm

KITS MARCOS

BLANCO
BLANC
WHITE
BIANCO
OB

NEGRO
NOR
BLACK
NERO
ON

BRUTO
BRUT
RAW
GREZZO
OO

COLOR
COULEUR
COLOR
COLORE
OP

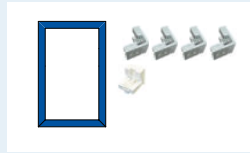

KIT 1 PUERTA
JEU POUR 1 PORTE
SET FOR 1 DOOR
SET PER 1 ANTE
5206/K..
incluye:
5206/3.. x3
5207/000 x4

max.1200mm €/u

o o o o

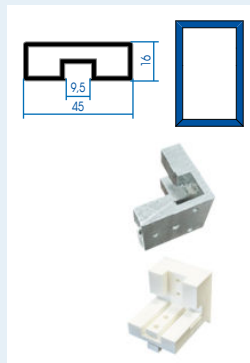

PERFIL LATERAL (MARCO)
PROFIL DE CADRE LATÉRAL
LATERAL FRAME PROFILE
PROFILO LATERALE CORNICE
5206/30.

Al 3M €/u

o o o o

ESQUADRA UNIÓN PERFILES
SUPPORT POUR ASSEMBLER DES PROFILS
BRACKET FOR JOINING PROFILES
GIUNTO UNIONE PROFILI
5207/000

Al €/u

o

GALGA ESCUADRA / MECANIZACIÓN PERIL
JAUGE CARRÉE
BRACKET GAUGE
CALIBRO SQUADRA
5207/010

PLÁSTICO
PLASTIQUE
PLASTIC
PLASTICA
09

Pla €/u

o

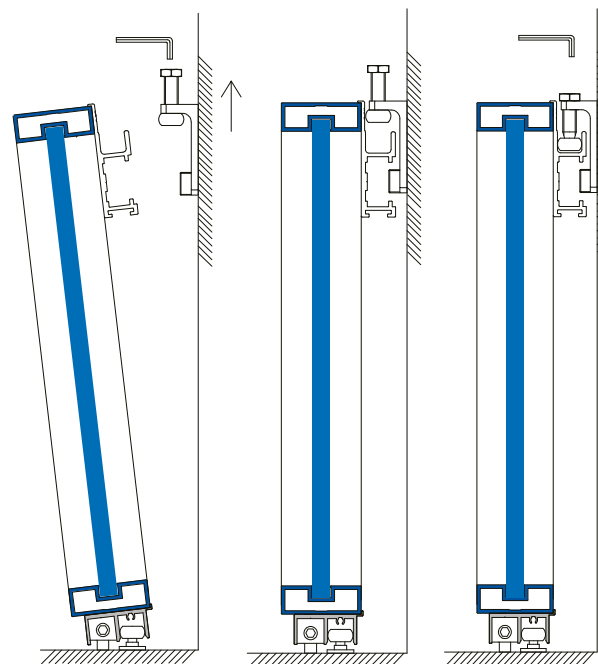
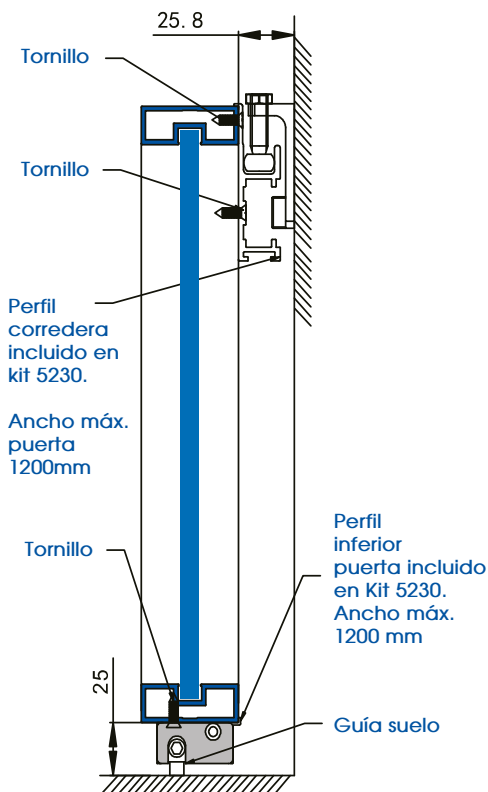

ANCHO MAX.1200mm

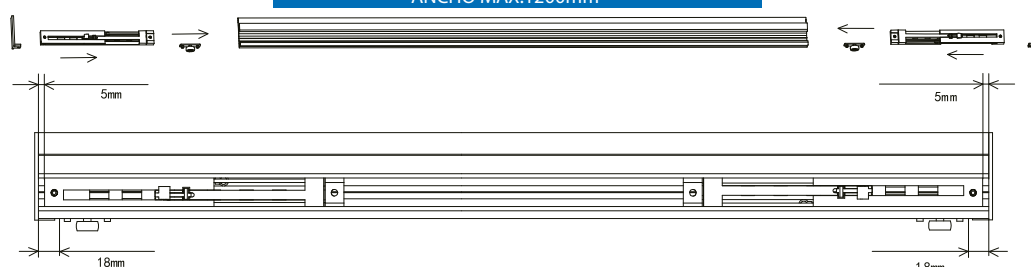

C. MARCO TELEX 2

PUERTA CORREDERA CON 2 PUERTAS TELESCÓPICAS

BLANCO BLANC WHITE BIANCO	NEGRO NOIR BLACK NERO	BRUTO BRUT RAW GREZZO	COLOR COULEUR COLOR COLORE
OB	ON	OO	OP

KITS

2 PUERTAS
TELESCÓPICAS

ANCHO PUERTA
HASTA 95

CARRIL 3M

REF. 5211/00.

X2	5111/30.
X2	5210/30.
X1	5200/00N
X2	5204/00.
X1	5208/00.

ANCHO PUERTA
MÁS DE 95

CARRIL 3M

REF. 5211/01.

X2	5111/30.
X2	5210/30.
X1	5200/00N
X2	5204/01.
X1	5208/00.

5211/00.	<input type="radio"/>	<input type="radio"/>	<input type="radio"/>	<input type="radio"/>
5211/01.	<input type="radio"/>	<input type="radio"/>	<input type="radio"/>	<input type="radio"/>

1 FIJO + 2 PUERTAS
TELESCÓPICAS

ANCHO PUERTA
HASTA 95

CARRIL 3M

REF. 5212/00.

X3	5111/30.
X2	5210/30.
X1	5200/00N
X3	5204/00.
X1	5208/00.
X1	5203/000

ANCHO PUERTA
MÁS DE 95

CARRIL 3M

REF. 5212/01.

X3	5111/30.
X2	5210/30.
X1	5200/00N
X3	5204/01.
X1	5208/00.
X1	5203/000

5212/00.	<input type="radio"/>	<input type="radio"/>	<input type="radio"/>	<input type="radio"/>
5212/01.	<input type="radio"/>	<input type="radio"/>	<input type="radio"/>	<input type="radio"/>



3M CINTA AUTOADHESIVA
VIDRIO MAX. CALIDAD.
TRANSPARENTE. PARA PERFILES
PUERTA JAPONESA
RUBAN ADHÉSIF DOUBLE FACE EN VERRE
GLASS DOUBLE SIDED TAPE
NASTRO BIADESIVO VETRO
5209/109
5209/009 ROLLO DE 33M

Pla €/m

PLÁSTICO
PLASTIQUE
PLASTIC
PLASTICA
09

CARRIL

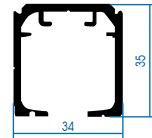

CARRIL SUPERIOR
RAIL EN ALUMINIUM
ALUMINIUM RAIL
BINARIO IN ALLUMINIO
5111/30. 3M

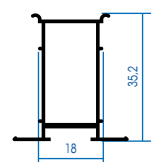

PERIL ENTRE CARRILES
PROFIL ENTRE RAILS
PROFILE BETWEEN RAILS
PROFILO TRA BINARI
5128/20. 2M
5128/30. 3M
5128/40. 4M

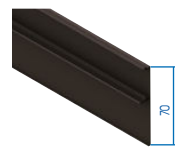

TAPA DE CARRIL SUPERIOR
COUVERTURE DE RAIL
SUPERIEURE
TOP RAIL COVER
COPERTURA SUPERIORE DEL
BINARIO
5210/30. 3M

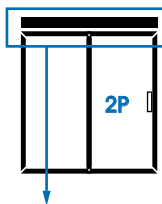

SET COJINETES PARA 2 PUERTAS
TELESCÓPICAS
JEU DE ROUEMENTS POUR 2
PORTES TÉLESCOPIQUES
SET OF FITTINGS FOR 2 TELESCOPIC
DOORS
SET CUSCINETTI PER 2 ANTE
TELESCOPICHE
5200/00N SELF-CLOSING



B Kit cojinete grande con ruedita
- carro
- ruedita
- cojinete grande

C Frenos tipo cubo

D Kit bufer
- bufer
- cojinete pequeño

E Frenos tipo bufer

F Kit cojinete pequeño con ruedita
- carro
- ruedita
- cojinete pequeño

G Kit cojinete pequeño sin ruedita
- carro
- cojinete pequeño

H Sujeta correa en techo

I Sujeta correa en cojinete

J Correa

K Pinza de correa

L Gulador en puerta

M Gulador en suelo

MARCOS

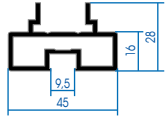

PERFIL INFERIOR Y SUPERIOR (MARCO)
PROFIL DE CADRE SUPÉRIEUR ET INFÉRIEUR
UPPER AND BOTTOM FRAME PROFILE
PROFILO SUPERIORE E INFERIORE CORNICE
5205/20.

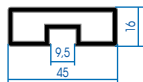

PERFIL LATERAL (MARCO)
PROFIL DE CADRE LATÉRAL
LATERAL FRAME PROFILE
PROFILO LATERALE CORNICE
5206/30.

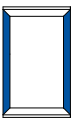

ESCUADRA UNIÓN PERFILES
SUPPORT POUR ASSEMBLER DES PROFILS
BRACKET FOR JOINING PROFILES
GIUNTO UNIONE PROFILI
5207/000



GALGA ESCUADRA / MECANIZACIÓN PERFIL
JAUGE CARRÉE
BRACKET GAUGE
CALIBRO SQUADRA
5207/010



KIT

KIT MARCO DE ALUMINIO 3X1M (1 PUERTA)
KIT CADRE DE ALUMINIUM 3X1M (1 PORTÉ)
SET ALUMINIUM FRAME 3X1M (1 FRAME)
CONGIUNTO PERIMETRALE DI ALUMINIO 3X1M
5204/00. ganchos hasta 90cm
5204/01. ganchos más de 90cm

- N** x2
- P** x4
- Q** x1

- N** Perfil inferior y superior (marco)
- P** Perfil lateral (marco)
- Q** Esquadra unión perfiles
- R** Cinta adhesiva vidrio

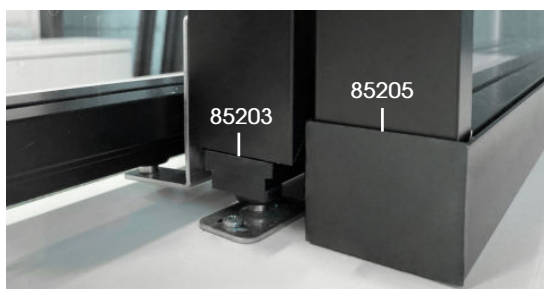

BLANCO BLANC WHITE BIANCO	NEGRO NOIR BLACK NERO	BRUTO BRUT RAW GREZZO	COLOR COULEUR COLOR COLORE
0B	0N	00	0P

Al 2 m €/u

Al 3 m €/u

Al €/u

Pla €/u

PLÁSTICO
PLASTIQUE
PLASTIC
PLÁSTICA
09 €/u

Al 2 m €/u

ACCESORIOS

BLANCO BLANC WHITE BIANCO	NEGRO NOIR BLACK NERO	BRUTO BRUT RAW GREZZO	COLOR COULEUR COLOR COLORE
0B	0N	00	0P



TIRADOR DOBLE PARA MARCO DE ALUMINIO
POIGNÉE DOUBLE POUR CADRE EN ALUMINIUM
DOUBLE HANDLE FOR ALUMINIUM FRAME
MANIGLIA DOPPIA
TELAIO IN ALLUMINIO
5208/00.

Al 213x46x13mm €/u



TIRADOR DOBLE CON PESTILLO PICO DE LORO
DOUBLE POIGNÉE DE VERROUILLAGE
DOUBLE HANDLE WITH LATCH
MANIGLIA DOPPIA CON CHIAVISTELLO
5216/00N

Al 213x46x13mm €/u



CERRADURA DE PUERTA ENMARCADA CON LLAVE PICO DE LORO
SERRURE DE PORTE ENCADRÉE AVEC CLÉ
FRAMED DOOR LOCK WITH KEY
SERRATURA PER PORTE CON CORNICE CON CHIAVE
5215/00N

Al 104x77x15mm €/u

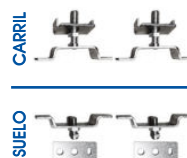

ANCLAJE PARA MARCO DE PUERTA FIJA
ANCRAGE DE CADRE DE PORTE FIXE
FIXED DOOR FRAME ANCHOR
ANCORAGGIO TELAIO PORTA FISSO
5203/000

Ix €/u



PERFIL ALUMINIO PARA CRISTAL-PUERTA DE PANEL JAPONÉS
PROFILÉ EN ALUMINIUM POUR LE VERRE DANS LA PORTE À PANNEAU JAPONAIS.
ALUMINIUM PROFILE FOR GLASS IN JAPANESE PANEL DOOR.
PROFILO IN ALLUMINIO PER VETRO IN ANTA A PANNELLO GIAPPONESE.
5127/30.

Al 15,6x10,1mm €/u
5209 3 m

Instrucciones de montaje en la página 15.



PERFIL EMBELLECEDOR EN "L"
PROFILÉ DE FINITION "L"
"L" FINISHING PROFILE
PROFILO DI FINITURA A "L"
5202/10.

Al 40x10x0,8mm €/m
 2 m

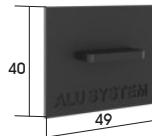

TAPETA EMBELLECEDORA
PROFILÉ DE FINITION "L"
"L" FINISHING PROFILE
PROFILO DI FINITURA A "L"
85205/00N

Pl 40x10x0,8mm €/u

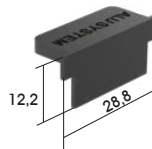

TAPETA EMBELLECEDORA
PROFILÉ DE FINITION "L"
"L" FINISHING PROFILE
PROFILO DI FINITURA A "L"
85203/00N

Pl 40x10x0,8mm €/u

C. MARCO TELEX 3

PUERTA CORREDERA CON 2 PUERTAS TELESCÓPICAS

KITS

BLANCO BLANC WHITE BIANCO	NEGRO NOIR BLACK NERO	BRUTO BRUT RAW GREZZO	COLOR COULEUR COLOR COLORE
OB	ON	OO	OP

3 PUERTAS
TELESCÓPICAS



ANCHO PUERTA
HASTA 95
CARRIL 4M

REF. 5213/00.

X3	5111/40.
X2	5210/40.
X1	5201/00N
X3	5204/00.
X1	5208/00.

ANCHO PUERTA
MÁS DE 95
CARRIL 4M

REF. 5213/01.

X3	5111/40.
X2	5210/40.
X1	5201/00N
X3	5204/01.
X1	5208/00.

5213/00.	<input type="radio"/>	<input type="radio"/>	<input type="radio"/>	<input type="radio"/>
5213/01.	<input type="radio"/>	<input type="radio"/>	<input type="radio"/>	<input type="radio"/>

3 PUERTAS
TELESCÓPICAS



ANCHO PUERTA
HASTA 95
CARRIL 4M

REF. 5214/00.

X4	5111/40.
X2	5210/40.
X1	5201/00N
X4	5204/00.
X1	5208/00.
X1	5203/000T

ANCHO PUERTA
MÁS DE 95
CARRIL 4M

REF. 5214/01.

X4	5111/40.
X2	5210/40.
X1	5201/00N
X4	5204/01.
X1	5208/00.
X1	5203/000

5214/00.	<input type="radio"/>	<input type="radio"/>	<input type="radio"/>	<input type="radio"/>
5214/01.	<input type="radio"/>	<input type="radio"/>	<input type="radio"/>	<input type="radio"/>

3M CINTA AUTOADHESIVA
VIDRIO MAX. CALIDAD.
TRANSPARENTE. PARA PERFILES
PUERTA JAPONESA
RUBAN ADHÉSIF DOUBLE FACE EN VERRRE
GLASS DOUBLE SIDED TAPE
NASTRO BIADESIVO VETRO
5209/109
5209/009 ROLLO DE 33M

Pla €/m

PLÁSTICO
PLASTIQUE
PLASTIC
PLASTICA
09

CARRIL

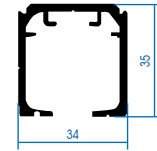

CARRIL SUPERIOR
RAIL EN ALUMINIUM
ALUMINIUM RAIL
BINARIO IN ALLUMINIO
5111/40. 4M

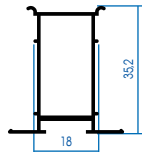

PERFIL ENTRE CARRILES
PROFIL ENTRE RAILS
PROFILE BETWEEN RAILS
PROFILO TRA BINARI
5128/20. 2M
5128/30. 3M
5128/40. 4M

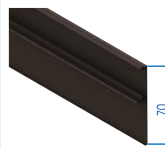

TAPA DE CARRIL SUPERIOR
COUVERTURE DE RAIL
SUPERIEURE
TOP RAIL COVER
COPERTURA SUPERIORE
DEL BINARIO
5210/40. 4M

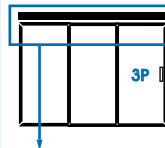

SET COJINETES PARA 3 PUERTAS
TELESCÓPICAS
JEU DE ROULEMENTS POUR 3
PORTES TÉLESCOPIQUES
SET OF FITTINGS FOR 3 TELESCOPIC
DOORS
SET CUSCINETTI PER 3 ANTE
TELESCOPICHE
5201/00N SELF-CLOSING



B Kit cojinete grande con ruedita
- carro
- ruedita
- cojinete grande

C Frenos tipo cubo

D Kit bufer
- bufer
- cojinete pequeño

E Frenos tipo bufer

F Kit cojinete pequeño con ruedita
- carro
- ruedita
- cojinete pequeño

G Kit cojinete pequeño sin ruedita
- carro
- cojinete pequeño

H Sujeta correa en techo

I Sujeta correa en cojinete

J Correa

K Pinza de correa

L Gulador en puerta

M Gulador en suelo

BLANCO BLANC WHITE BIANCO	NEGRO NOIR BLACK NERO	BRUTO BRUT RAW GREZZO	COLOR COULEUR COLOR COLORE
OB	ON	OO	OP

Al 4 m €/u

Al 2M 3M 4M €/u

Al 4 m €/u

€/u

MARCOS

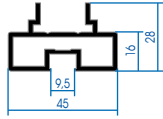

PERFIL INFERIOR Y SUPERIOR (MARCO)
PROFIL DE CADRE SUPÉRIEUR
ET INFÉRIEUR
UPPER AND BOTTOM
FRAME PROFILE
PROFILO SUPERIORE E
INFERIORE CORNICE
5205/20.

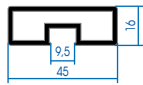
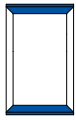

PERFIL LATERAL (MARCO)
PROFIL DE CADRE LATÉRAL
LATERAL FRAME PROFILE
PROFILO LATERALE CORNICE
5206/30.

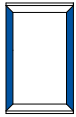

ESCUADRA UNIÓN PERFILES
SUPPERT POUR ASSEMBLER DES
PROFILS
BRACKET FOR JOINING PROFILES
GIUNTO UNIONE PROFILI
5207/000



**GALGA ESCUADRA /
MECANIZACIÓN PERFIL**
JAUGE CARRÉE
BRACKET GAUGE
CALIBRO SQUADRA
5207/010



KIT MARCO DE ALUMINIO 3X1M
(1 PUERTA)
KIT CADRE DE ALLUMINIUM
3X1M (1 PORTE)
SET ALUMINIUM FRAME
3X1M (1 FRAME)
CONGIUNTO PERIMETRALE
DI ALLUMINIO 3X1M
5204/00. ancho hasta 95cm
5204/01. ancho más de 95cm



- N** Perfil inferior y superior (marco)
- O** Perfil lateral (marco)
- P** Escuadra unión perfiles
- Q** Cinta adhesiva vidrio

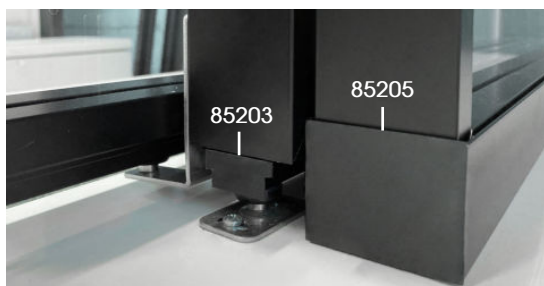

ACCESORIOS



TIRADOR DOBLE PARA MARCO DE ALUMINIO
POIGNÉE DOUBLE POUR CADRE EN ALUMINIUM
DOUBLE HANDLE FOR ALUMINIUM FRAME
MANIGLIA DOPPIA
TELAIO IN ALLUMINIO
5208/00.



TIRADOR DOBLE CON PESTILLO PICO DE LORO
DOUBLE POIGNÉE DE VERROUILLAGE
DOUBLE HANDLE WITH LATCH
MANIGLIA DOPPIA CON CHIAVISTELLO
5216/00N



CERRADURA DE PUERTA ENMARCADA CON LLAVE PICO DE LORO
SERRURE DE PORTE ENCADRÉE AVEC CLÉ
FRAMED DOOR LOCK WITH KEY
SERRATURA PER PORTE CON CORNICE CON CHIAVE
5215/00N



ANCLAJE PARA MARCO DE PUERTA FIJA
ANCRAGE DE CADRE DE PORTE FIXE
FIXED DOOR FRAME ANCHOR
ANCORAGGIO TELAIO PORTA FISSO
5203/000



PERFIL ALUMINIO PARA CRISTAL-PUERTA DE PANEL JAPONÉS
PROFILÉ EN ALUMINIUM POUR LE VERRRE DANS LA PORTE A PANNEAU JAPONAIS.
ALUMINIUM PROFILE FOR GLASS IN JAPANESE PANEL DOOR.
PROFILO IN ALLUMINIO PER VETRO IN ANTA A PANNELLO GIAPPONESE.
5127/30.



PERFIL EMBELLECEDOR EN "L"
PROFILÉ DE FINITION "L"
"L" FINISHING PROFILE
PROFILO DI FINITURA A "L"
5202/1..

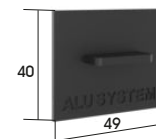

TAPETA EMBELLECEDORA
PROFILÉ DE FINITION "L"
"L" FINISHING PROFILE
PROFILO DI FINITURA A "L"
85205/00N

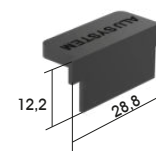

TAPETA EMBELLECEDORA
PROFILÉ DE FINITION "L"
"L" FINISHING PROFILE
PROFILO DI FINITURA A "L"
85203/00N

BLANCO BLANC WHITE BIANCO	NEGRO NOIR BLACK NERO	BRUTO BRUT RAW GREZZO	COLOR COULEUR COLOR COLORE
OB	ON	OO	OP

BLANCO WHITE BIANCO	NEGRO BLACK NERO	BRUTO RAW GREZZO	COLOR COULEUR COLOR COLORE
OB	ON	OO	OP

Al	2 m	€/u
----	-----	-----

Al	3 m	€/u
----	-----	-----

Al	€/u
----	-----

Pla	€/u
-----	-----

PLÁSTICO PLASTIC PLASTICA	09	€/u
---------------------------------	----	-----

Al	2 m	€/u
----	-----	-----

Al	213x46x13mm	€/u
----	-------------	-----

Al	213x46x13mm	€/u
----	-------------	-----

Al	104x77x15mm	€/u
----	-------------	-----



lx	€/u
----	-----

Al	15,6x10,1mm	€/u
----	-------------	-----

5209	3 m
------	-----

Al	40x10x0,8mm	€/m
----	-------------	-----



Pl	40x10x0,8mm	€/u
----	-------------	-----

Pl	40x10x0,8mm	€/u
----	-------------	-----

CÁLCULO DE MEDIDAS CANTON TELEX 2

2 PUERTAS CORREDERAS ALINEADAS EN PARKING

Ancho mínimo de puerta 2180mm
max. 2811mm

F = MEDIDA PUERTA FIJA
A = MEDIDA PUERTAS CORREDERAS

$$F = \frac{(\text{HUECO} + 32)}{3} + 5 \quad A = \frac{L}{2} + 16$$

$$L = \text{HUECO} - F$$

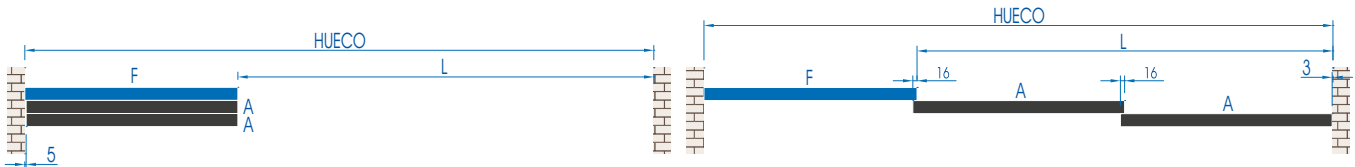

2 PUERTAS CORREDERAS CON TIRADOR SALIENTE

Ancho mínimo de puerta 2260mm
max. 2666mm

G = MEDIDA SALIENTE PARA EL TIRADOR
F = MEDIDA PUERTA FIJA
A = MEDIDA PUERTA CORREDERA INTERMEDIA
B = PUERTA FINAL CON TIRADOR SALIENTE

$$F = \frac{(\text{HUECO} - 3 - 5 - G + 16 \times 2)}{3} + 5 \quad A = \frac{(\text{HUECO} - 3 - 5 - G + 16 \times 2)}{3}$$

$$L = \text{HUECO} - F \quad B = A + G$$

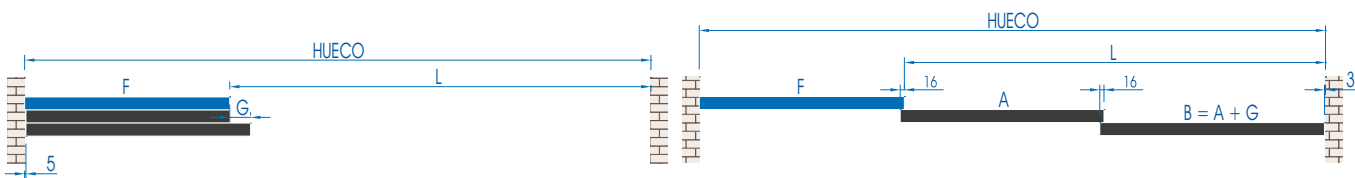

CÁLCULO DE MEDIDAS CANTON TELEX 3

3 PUERTAS CORREDERAS ALINEADAS EN PARKING

Ancho mínimo de puerta 2900mm
max. 3740mm

F = MEDIDA PUERTA FIJA
A = MEDIDA PUERTAS CORREDERAS

$$F = \frac{(\text{HUECO} + 58)}{4} + 15 \quad A = \frac{L}{3} + 15 \quad L = \text{HUECO} - F$$

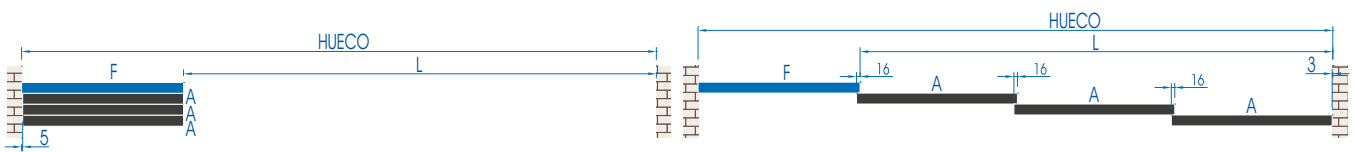

3 PUERTAS CORREDERAS CON TIRADOR SALIENTE

Ancho mínimo de puerta 2980mm
max. 3520mm

G = MEDIDA SALIENTE PARA EL TIRADOR
F = MEDIDA PUERTA FIJA
A = MEDIDA PUERTA CORREDERA INTERMEDIA
B = PUERTA FINAL CON TIRADOR SALIENTE

$$F = \frac{\text{HUECO} - G}{4} + 16 \quad A = \frac{L - G}{3} + 15 \quad B = \frac{L - G}{3} + G + 15$$

$$L = \text{HUECO} - F$$

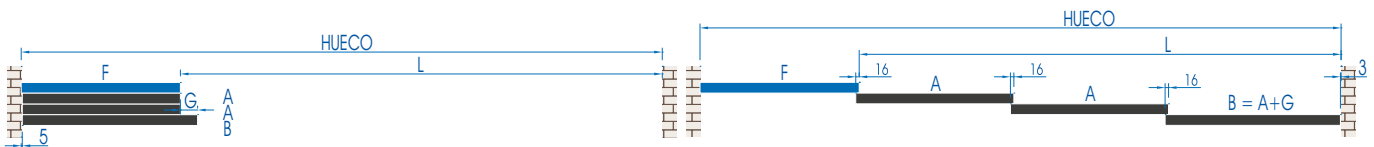

*** SOLICITE LA HOJA DE
CÁLCULO DE MEDIDAS**

DATOS TÉCNICOS

SECCIONES PERFILES

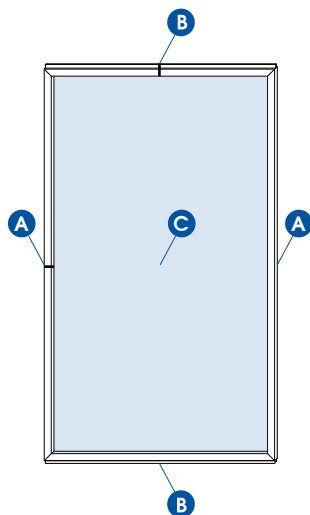

A Sección Perfil A

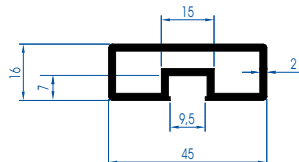

B Sección Perfil B

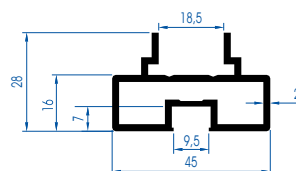

MEDIDAS VIDRIO →

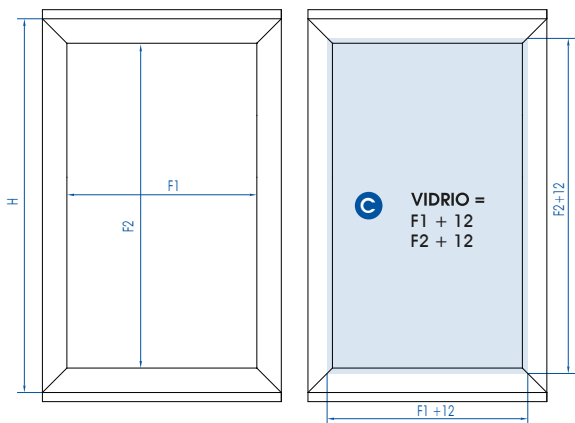

ANCLAJE Instalación a techo
Ceiling mounted

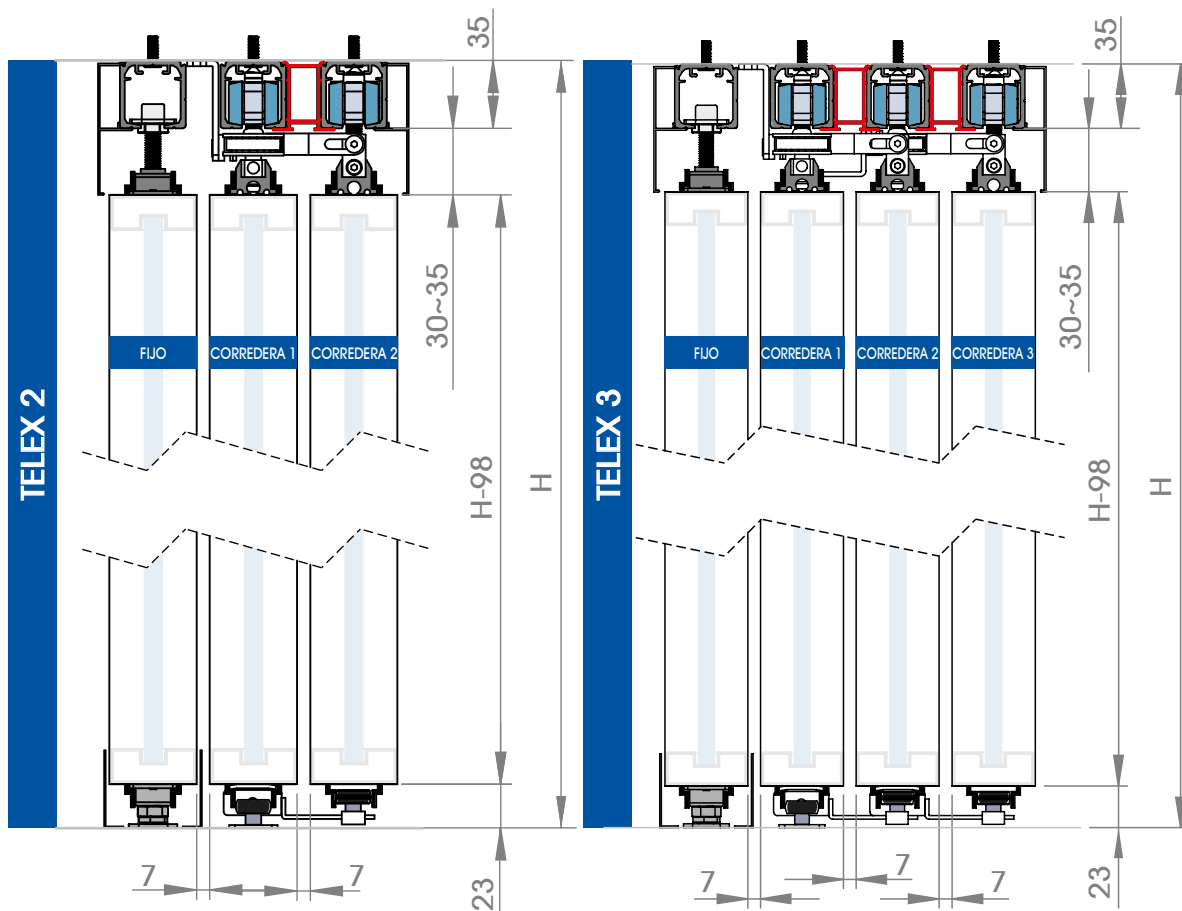

C. MARCO TELEX MOVE

PUERTA TELESCÓPICA CON PUERTAS MÓVILES EN LOS 2 SENTIDOS

IMÁGEN	DESCRIPCIÓN	ESPECIFICACIONES	MATERIAL / REFERENCIA	ACABADOS / PRECIOS - Euro/u.	
CANTÓN MARCO TELEX MOVE - PUERTA TELESCÓPICA					
	PUERTA CORREDERA TELESCÓPICA ENMARCADA CON MOVIMIENTO LIBRE HACIA AMBOS LADOS Y SELF-CLOSING <i>Porte coulissante télescopique encadré de mouvement libre des deux côtés et à fermeture automatique</i> <i>Telescopic sliding door framed with movement free on both sides and self-closing</i> <i>Porta scorrevole telescopica incorniciata dal movimento libero su entrambi i lati e chiusura automatica</i>	8 mm Max. 80 kg/puerta Sistema basado los herrajes comunes del sistema de la familia Cantón. Nueva gama de puertas telescópicas de libre movimiento en ambos lados y self-closing (con auto cierre y amortiguador de golpe). (Vidrios 8mm hasta 40 kg de peso/puerta).	Al Cu 5190/00. 3 PUERTAS HASTA 95CM 3P. Al Cu 5190/01. 3 PUERTAS MÁS DE 95CM Al Cu 5191/00. 4 PUERTAS HASTA 95CM 4P. Al Cu 5191/01. 4 PUERTAS MÁS DE 95CM	OB ON OO OP	
	Se sirve sin vidrio				
	TELEX MOVE 3P. HASTA 95 componentes:	- (X1) 5198/00N (3P) - (X3) 5204/00. - (X2) 5208/00.	- (X6) 85203/00N	CARRIL, TAPA Y SEPARADORES NO INCLUIDOS	
	TELEX MOVE 3P. ± DE 95 componentes:	- (X1) 5198/00N (3P) - (X3) 5204/01. - (X2) 5208/00.	- (X6) 85203/00N	CARRIL, TAPA Y SEPARADORES NO INCLUIDOS	
	TELEX MOVE 4P. HASTA 95 componentes:	- (X1) 5199/00N (4P) - (X4) 5204/00. - (X2) 5208/00.	- (X8) 85203/00N	CARRIL, TAPA Y SEPARADORES NO INCLUIDOS	
TELEX MOVE 4P. ± DE 95 componentes:	- (X1) 5199/00N (4P) - (X4) 5204/01. - (X2) 5208/00.	- (X8) 85203/00N	CARRIL, TAPA Y SEPARADORES NO INCLUIDOS		

NOVEDAD

IMÁGEN	DESCRIPCIÓN	ESPECIFICACIONES	MATERIAL / REFERENCIA	ACABADOS / PRECIOS - Euro/u.
COMPONENTES CANTÓN MARCO TELEX MOVE				
	SET COJINETES 3P. TELESCÓPICAS <i>Jeu de roulements pour 2p. télescopiques</i> <i>bearing set 2 telescopic doors</i> <i>set cuscinetti per 2 ante telescopiche</i>		5198/00N	OB ON OO OP O9
	SET COJINETES 4P. TELESCÓPICAS <i>Jeu de roulements pour 3p. télescopiques</i> <i>bearing set 3 telescopic doors</i> <i>set cuscinetti per 3 ante telescopiche</i>		5199/00N	OB ON OO OP O9
	CARRIL SUPERIOR <i>Rail en aluminium</i> <i>Aluminium rail</i> <i>Binario in alluminio</i>	3M 4M	Al 5111/30. Al 5111/40.	OB ON OO OP O9
	TAPA DE CARRIL SUPERIOR <i>Couverture de rail supérieure</i> <i>Top rail cover</i> <i>Copertura superiore</i>	3M 4M	Al 5210/30. Al 5210/40.	OB ON OO OP O9
	PERFIL SEPARACIÓN ENTRE CARRILES <i>Profil de séparation des voies</i> <i>Lane separation profile</i> <i>Profilo di separazione delle corsie</i>	3M 4M	Al 5128/30. Al 5128/40.	OB ON OO OP O9
	PERFIL INFERIOR Y SUPERIOR (MARCO) <i>Profil de cadre supérieur et inférieur</i> <i>Upper and bottom frame profile</i> <i>Profilo superiore e inferiore cornice</i>	2M	Al 5205/20.	OB ON OO OP O9
	PERFIL LATERAL (MARCO) <i>Profil de cadre latéral</i> <i>Lateral frame profile</i> <i>Profilo laterale cornice</i>	3M	Al 5206/30.	OB ON OO OP O9
	ESCUADRA UNIÓN PERFILES <i>Profil de cadre latéral</i> <i>Lateral frame profile</i> <i>Profilo laterale cornice</i>		Al 5207/000	OB ON OO OP O9
	GALGA ESCUADRA / MECANIZACIÓN PERFIL <i>Profil de cadre latéral</i> <i>Lateral frame profile</i> <i>Profilo laterale cornice</i>		PI 5207/010	OB ON OO OP O9
	KIT MARCO DE ALUMINIO 3x1M (1 PUERTA) <i>Kit cadre de aluminium 3x1M (1 porté)</i> <i>Set aluminium frame 3x1M (1 frame)</i> <i>Congiunto perimetrale di alluminio 3x1M</i>		Al ANCHO HASTA 95CM 5204/00. Al ANCHO +DE 95CM 5204/01.	OB ON OO OP O9
	PERFIL ALUMINIO PARA CRISTAL-PUERTA DE PANEL JAPONÉS <i>Profilé en aluminium pour le verre dans la porte à panneau japonais</i> <i>Aluminium profile for glass in Japanese panel door</i> <i>Profilo in alluminio per vetro in anta a pannello giapponese</i>	4M	Al 5127/30.	OB ON OO OP O9
	TAPETA EMBELLECEDORA <i>garniture de couverture</i> <i>trim cover</i> <i>rivestimento di rifinitura</i>	12,2x28,8x0,8mm	PI 85203/00N	OB ON OO OP O9
	PERFIL LATERAL (MARCO) <i>Profil de cadre latéral</i> <i>Lateral frame profile</i> <i>Profilo laterale cornice</i>		PI 5209/109 PI ROLLO DE 33M 5209/009	OB ON OO OP O9

IMÁGEN	DESCRIPCIÓN	ESPECIFICACIONES	MATERIAL / REFERENCIA	ACABADOS / PRECIOS - Euro/u.
COMPONENTES CANTÓN MARCO TELEX MOVE				
	TIRADOR DOBLE PARA MARCO DE ALUMINIO <i>Poignée double pour cadre en aluminium</i> Double handle for aluminium frame <i>Maniglia doppia telaio in alluminio</i>	213x46x13mm	Al 5208/00.	○ OB ● ON ○ OO ● OP
	TIRADOR DOBLE CON PESTILLO PICO DE LORO <i>Double poignée de verrouillage</i> Double handle with latch <i>Maniglia doppia con chiovistello</i>	213x46x13mm	Al 5216/00N	○
	CERRADURA DE PUERTA ENMARCADA CON LLAVE PICO DE LORO <i>Serrure de porte encadrée avec clé</i> Framed door lock with key <i>Serratura per porte con cornice con chiave</i>	213x46x13mm	Al 5215/00N	○

MEDIDAS Y DESCUENTOS TELEX MOVE

TELEX MOVE 3 PUERTAS

TELEX MOVE 4 PUERTAS

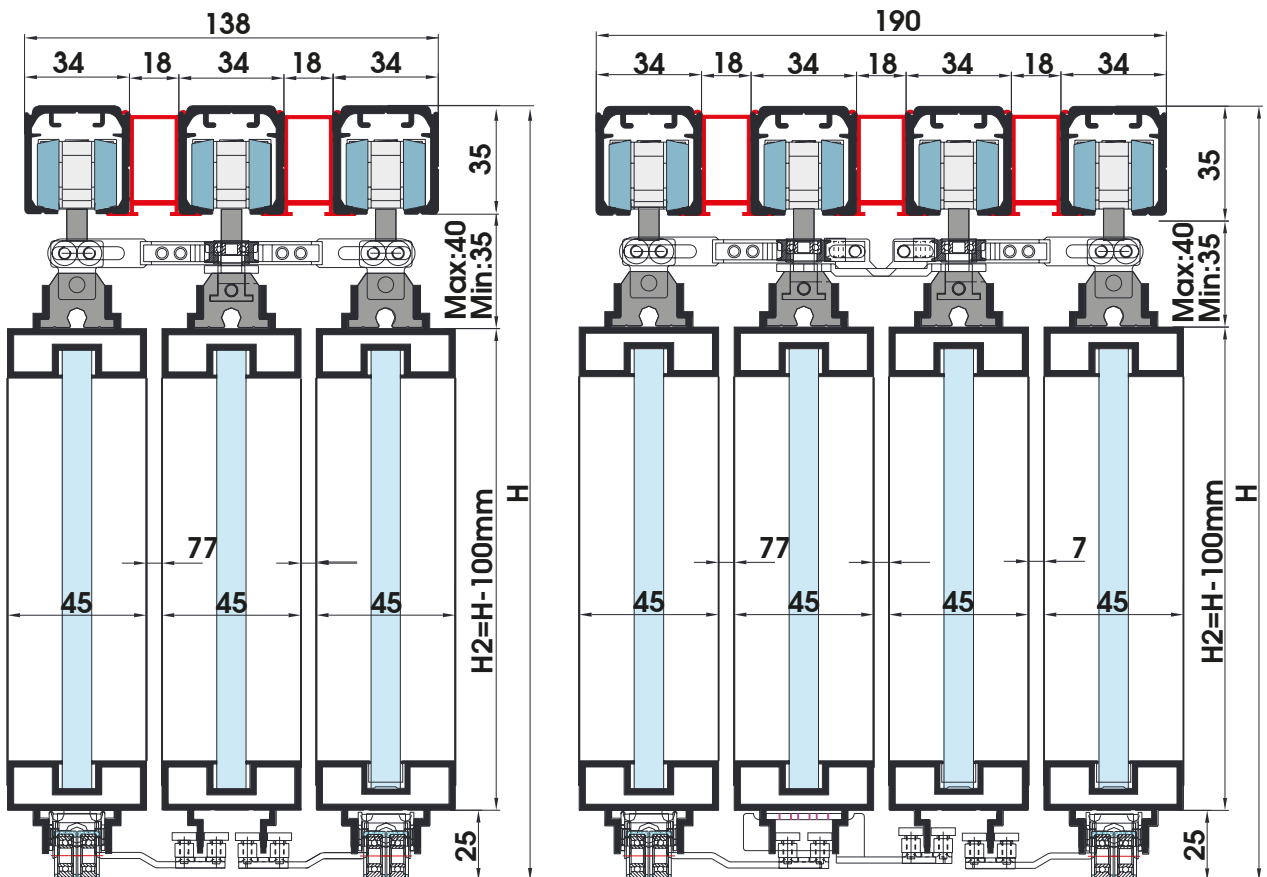

VÍDEO DE MONTAJE



CÁLCULO DE MEDIDAS (C.M. TELEX MOVE)

PUERTA TELESCÓPICA CON PUERTAS
MÓVILES EN LOS 2 SENTIDOS

ANCHO DE PUERTA (P) =
HUECO (H) / 3 - 34 mm

H = Max. 3566 mm / Min. 1706 mm
P = Max. 1200 mm / Min. 580 mm
S = 16 mm

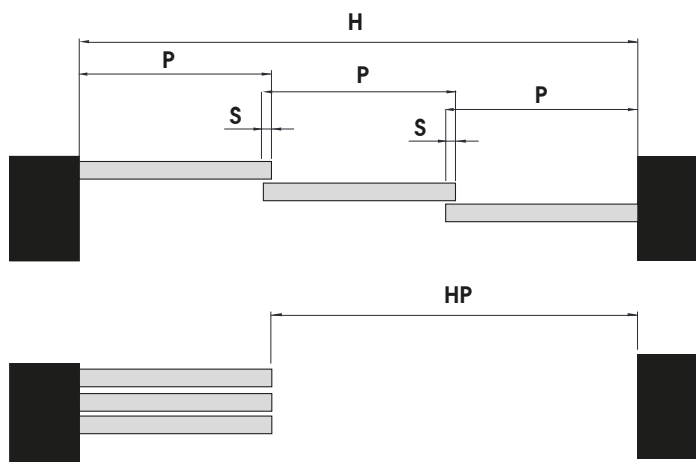

HP = Max. 2367 mm
Min. 1127 mm

TELEX MOVE 4 PUERTAS

ANCHO DE PUERTA (P) =
HUECO (H) / 4 - 50 mm

H = Max. 4000 mm / Min. 2270 mm
P = Max. 1012,5 mm / Min. 580 mm
S = 16 mm

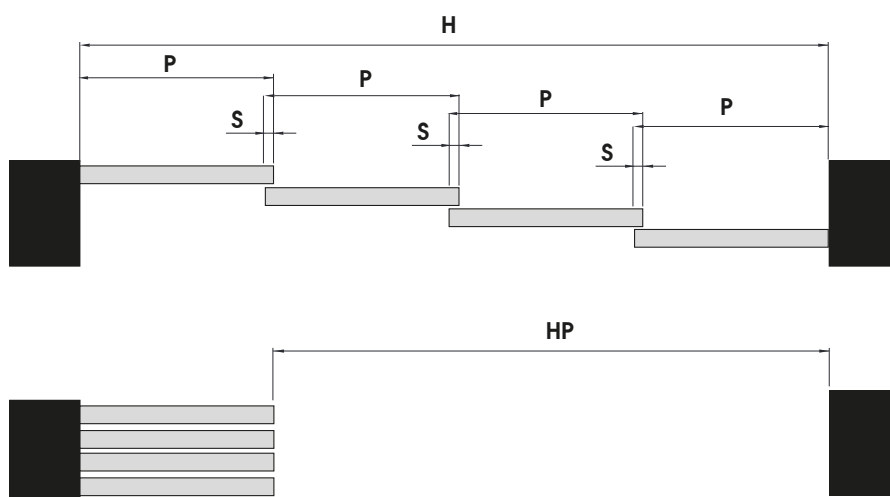

HP = Max. 2987 mm
Min. 1690 mm



MOVIMIENTO LIBRE HACIA LOS DOS LADOS

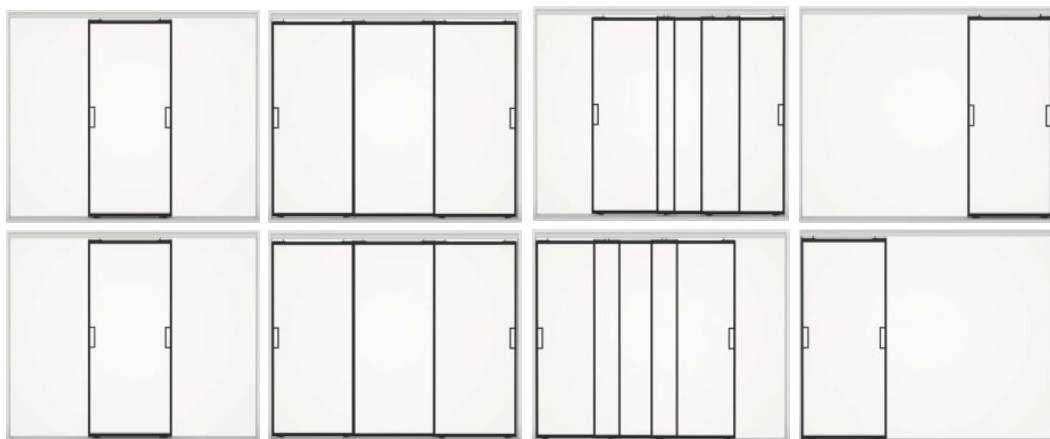

C. Marco Pivotante

PUERTA PIVOTANTE DE VIDRIO ENMARCADO

ACCESORIOS P. VAYVEN

NEGRO NOIR BLACK NERO	INOX SAT. INOX SAT. S.S.S INOX SAT.
0N	28

	lx	€/u
PIVOTE INFERIOR CON RODAMIENTO TIPO "DORMA" PIVOT INFÉRIEUR AVEC ROULEMENT DE TYPE "DORMA" LOWER PIVOT WITH "DORMA" TYPE BEARING PERNO INFERIORE CON CUSCINETTO DI TIPO "DORMA" 5219/028		o
		o
HERRAJES PARA PIVOTANTE TIPO "DORMA" RACCORDS POUR PIVOT TYPE "DORMA" FITTINGS FOR PIVOT, "DORMA" TYPE RACCORDI PER PERNO TIPO "DORMA" 5221/028		o
	lx	70kg €/u
KIT FRENO DE AIRE PARA SUELO KIT DE FREIN PNEUMATIQUE AU SOL AIR FLOOR SPRING KIT KIT FRENO PNEUMATICO A PAVIMENTO 5220/028		o

ACCESORIOS P. BATIENTE

	In	5224 €/u
BISAGRA PIVOTANTE OCULTA CHARNIÈRE À PIVOT DISSIMULÉE CONCEALED PIVOT HINGE CERNIERA A BILICO NASCOSTA *5224/028	60kg	o
	Al	5224 €/u
BISAGRAS PARA PUERTA BATIENTE CHARNIÈRES POUR PORTE PIVOTANTE HINGES FOR PIVOT DOOR CERNIERE PER PORTA A BILICO 5223/00N	40kg	o
	Al	5224 €/u
BISAGRAS PARA PUERTA BATIENTE CHARNIÈRES POUR PORTE PIVOTANTE HINGES FOR PIVOT DOOR CERNIERE PER PORTA A BILICO 5225/D0N 5225/Z0N	80kg	o
	Al	5224 €/u
BISAGRAS PARA PUERTA BATIENTE CHARNIÈRES POUR PORTE PIVOTANTE HINGES FOR PIVOT DOOR CERNIERE PER PORTA A BILICO 5229/00N	40kg	o
	Inox	5224 €/u
BISAGRAS PARA PUERTA BATIENTE CHARNIÈRES POUR PORTE PIVOTANTE HINGES FOR PIVOT DOOR CERNIERE PER PORTA A BILICO 5228/00N	80kg	o
	lx	€/u
ANCLAJE PARA MARCO DE PUERTA FIJA ANCRAGE DE CADRE DE PORTE FIXE FIXED DOOR FRAME ANCHOR ANCORAGGIO TELAIO PORTA FISSO 5203/T00		o

PERFILERÍA PUERTA

BLANCO BLANC WHITE BIANCO	NEGRO NOIR BLACK NERO	BRUTO BRUT RAW GREZZO	COLOR COULEUR COLOR COLORE
0B	0N	00	0P

	Al	2 m	€/u
PERFIL INFERIOR Y SUPERIOR (MARCO) PROFIL DE CADRE SUPÉRIEUR ET INFÉRIEUR UPPER AND BOTTOM FRAME PROFILE PROFILO SUPERIORE E INFERIORE CORNICE 5205/20.			o
	Al	3 m	€/u
PERFIL LATERAL (MARCO) PROFIL DE CADRE LATÉRAL LATERAL FRAME PROFILE PROFILO LATERALE CORNICE 5206/30.			o
	Al		€/u
ESQUADRA UNIÓN PERFILES SUPPORT POUR ASSEMBLER DES PROFILS BRACKET FOR JOINING PROFILES GIUNTO UNIONE PROFILI 5207/000			o
	Pla	€/u	PLÁSTICO PLASTIQUE PLASTIC PLASTICA 09
GALGA ESCUADRA / MECANIZACIÓN PERFIL JAUGE CARRÉE BRACKET GAUGE CALIBRO SQUADRA 5207/010			o

PERFIL MARCO PUERTA

	Al	2,2 m	5227 €/u
PERFIL MARCO EMBELLECEDOR CIERRE PROFIL DE CADRE DE FINITION CLOSING TRIM FRAME PROFILE PROFILO DEL TELAIO DI CHIUSURA *5224/20N 2,2M *5224/30N 3M			*o
	PVC		€/m
JUNTA MARCO PUERTA. JOINT DE CADRE DE PORTE DOOR FRAME GASKET GUARNIZIONE TELAIO PORTA *5224/109			*o
	Al	5224 €/u	
ESCUADRAS PARA PERFIL 5224 ANGLES POUR PROFIL 5224 ANGLES FOR PROFILE 5224 ANGOLI PER PROFILO 5224 *5227/000			*o

PERFIL PARA PUERTA JAPONESA

	Al	3 m	5209	15,6x10,1mm	€/u
PERFIL ALUMINIO PARA CRISTAL-PUERTA DE PANEL JAPONÉS PROFILÉ EN ALUMINIUM POUR LE VERRE DANS LA PORTE À PANNEAU JAPONAIS. ALUMINIUM PROFILE FOR GLASS IN JAPANESE PANEL DOOR. PROFILO IN ALLUMINIO PER VETRO IN ANTA A PANNELLO GIAPPONESE. 5127/30.					o

Ver instrucciones de montaje.

ACCESORIOS



CINTA ADHESIVA VIDRIO
RUBAN ADHÉSIF DOUBLE
FACE EN VERRE
GLASS DOUBLE SIDED TAPE
NASTRO BIADIESIVO VETRO
5209/109
5209/009 ROLLO DE 33M

BRUTO BRUT GREZZO	NEGRO NOIR BLACK NERO
09	0N

Pla	€/m
<input type="radio"/>	<input type="radio"/>

Al		8 mm	€/u
----	--	------	-----

SMART LOCK - CERRADURA DIGITAL CON TOUCH ID
SMART LOCK - SERRURE ÉLECTRONIQUE AVEC TOUCH ID
SMART LOCK - DIGITAL LOCK WITH TOUCH ID
SMART LOCK - SERRATURA DIGITALE CON TOUCH ID
5541/00N

NOVEDAD

Al		8 mm	€/u
----	--	------	-----

CERRADURA CON MANETA Y CONTRACERRADURA A PARED (CON CONDENA)
SERRURE AVEC POIGNÉE ET GÂCHE MUR (AVEC CLÉ)
DOOR LOCK WITH HANDLE AND STRIKE PLATE (WITH KEY)
SERRATURA CON MANIGLIA E CONTOSERRATURA MURO (CON CHIAVE)
5218/00N

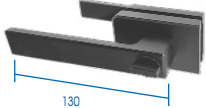

Al		8 mm	€/u
----	--	------	-----

CERRADURA CON MANETA Y CONTRACERRADURA A PARED (CON LLAVE)
SERRURE AVEC POIGNÉE ET GÂCHE MUR (AVEC CLÉ)
DOOR LOCK WITH HANDLE AND STRIKE PLATE (WITH KEY)
SERRATURA CON MANIGLIA E CONTOSERRATURA MURO (CON CHIAVE)
5217/00N

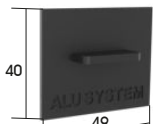
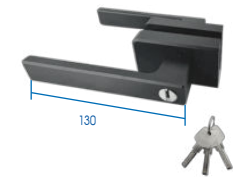

TAPETA EMBELLECEDORA
PROFILÉ DE FINITION "L"
"L" FINISHING PROFILE
PROFILO DI FINITURA A "L"
85205/00.

PI	40x10x0,8mm	€/u
----	-------------	-----

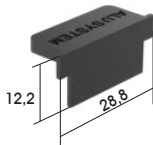

TAPETA EMBELLECEDORA
PROFILÉ DE FINITION "L"
"L" FINISHING PROFILE
PROFILO DI FINITURA A "L"
85203/00.

PI	40x10x0,8mm	€/u
----	-------------	-----

**PUERTA PIVOTANTE
CON FRENO AIRE**



**PUERTA PIVOTANTE
CON TEJUELO**



MEDIDA VIDRIO

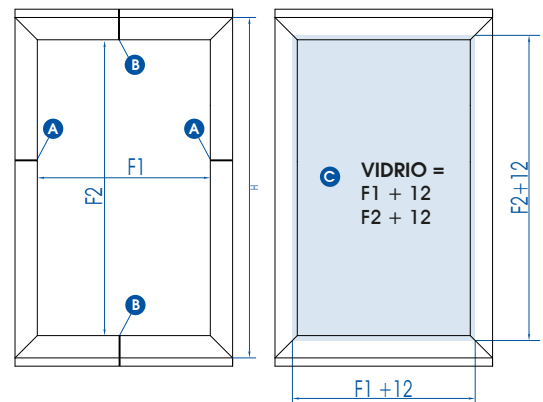

PERFILES PARA SISTEMAS: 5219 +5221 O 5220

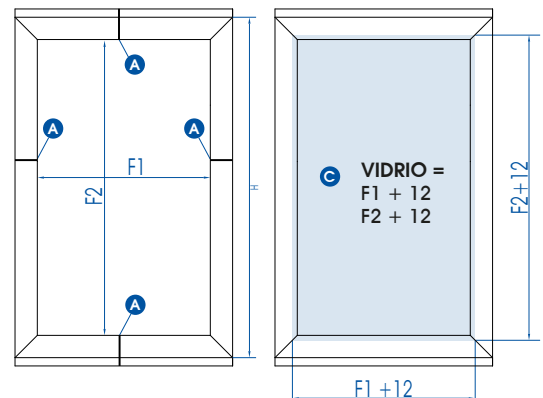

PERFILES PARA SISTEMAS: 5224 , 5223, 5225, 5228, 5229



CORREDERA KUBE

- peso max. puerta:
80 kg/puerta
- vidrio 8-10 mm
- sin muesca en el vidrio

- pods-limite porte: 80 kg/porte
- verre 8-10 mm
- sans encoches
- weight max. door: 80 kg/door
- glass 8-10 mm
- without cut-out
- peso max. porta: 80 kg/porta
- vetro 8-10 mm
- senza tacca nel vetro

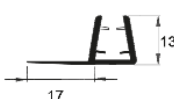
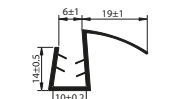
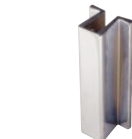
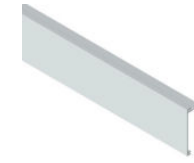
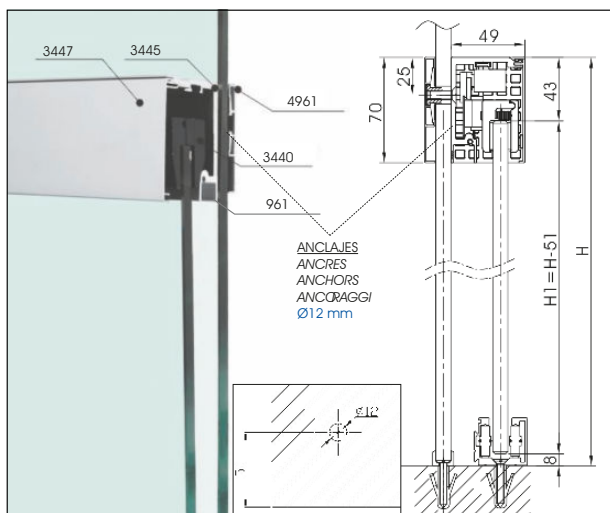
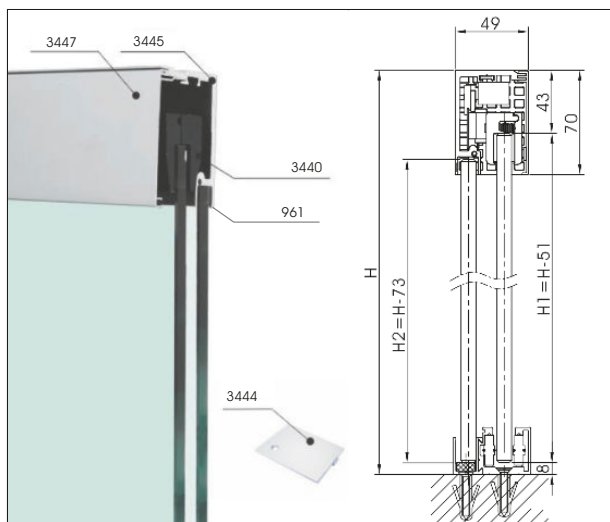
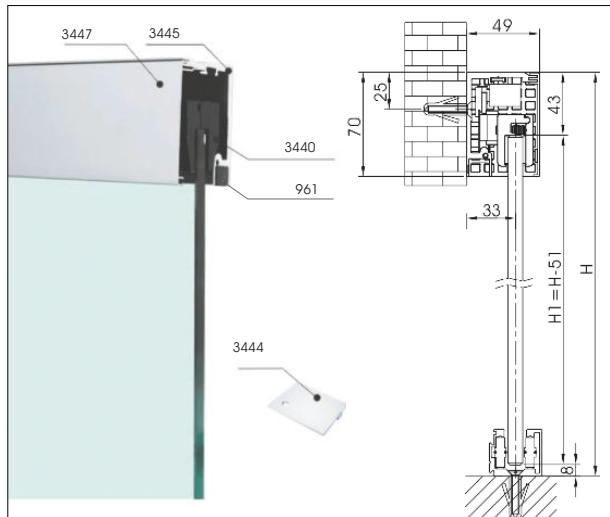

CARRIL
COULISSE HAUTE
UPPER TRACK
GUIDA SUPERIORE
3445/201 1,93 m
3445/301 2,90 m
3445/501 5,80 m

PERFIL TAPA CARRIL
PROFIL COUVERTURE COULISSE
TRACK COVER PROFIL
PROFILO COPERTINA GUIDA
3447/201 1,93 m
3447/301 2,90 m
3447/501 5,80 m

PERFIL INFERIOR VIDRIO FIJO
PROFIL INFERIEUR VERRE FIXE
BOTTOM PROFILE FIXED GLASS
PROFILO INFERIORE VETROFISSO
Se acopla a 4964 y 4965
4963/101 0,96 m
4963/201 1,45 m
4963/301 2,90 m

PERFIL SOPORTE A PARED
DE VIDRIO + 9 ANCLAJES
PROFIL SUPPORT MUR DE
VERRE + 9 ANCRÉS
PROFILE WALL-GLASS SUPPORT + 9 ANCHORS
PROFILO SUPPORTO A PARETE DI VETRO + 9 ANCOAGGI
4961/201 1,93 m
4961/301 2,90 m
4961/501 5,80 m

KIT PINZA PORTAVIDRIO
CON AMORTIGUADORES
KIT DE PINCES POUR
PORTE-VERRE AVEC
AMORTISSEURS
GLASS HOLDER CLAMP KIT
WITH SHOCK ABSORBERS
KIT MORSETTO PORTA VETRO
CON AMMORTIZZATORI
3440/011

ANCLAJE CARRIL-PARED
SUPPORT PROFIL-MUR
SUPPORT PROFIL-WALL
UNIONE PROFILO-PARETE
3454/011 SET 2 U.

UÑERO DOBLE ADHESIVO
POIGNÉE DOUBLE ADHESIVE
DOUBLE ADHESIVE PULL
POMO DOPPIO ADHESIVO
4207/0..
4207/0..

PERFIL TAPABOCAS
PROFIL COUVERTURE
COVER PROFIL
PROFILO COPRI-CANALE
*961/101

POMO
POIGNÉE
KNOB
POMO
4223/0..

GUÍA SUELO VIDRIO
GUIDAGE AU SOL VERRE
FLOOR GUIDE GLASS
GUIDA A PAVIMENTO VETRO
3488/022

PERFIL INFERIOR
PROF ÉTANCHEITÉ
SEAL
GIUNTA
1856/109

PERFIL LATERAL CORREDERA
PROF ÉTANCHEITÉ COULISSENT
SLIDING DOOR SEAL
GIUNTA PORTA SCORREVOLE
1852/209 8 mm
1853/209 10 mm

CR. BRILLO	PL. M	BRUTO	PLÁSTICO
CH. POL	ALU. M	BRUT	PLASTICU E
CR. LUC.	ALU. M	RAW	PLASTIC C
	ALL. NAT	GREZZO	PLASTICA
32	01	00	09
Al	5,8m	48x70	€/m
		10-12 mm	
		o	
		o	
		o	
Al	5,8m	70x7	€/m
		o	
		o	
		o	
Al	5,8m	26x19,2	€/m
		10-12 mm	∞ 4964-4965
		o	
		o	
		o	
Al	5,8m	70x7	€/m
		∅ 12 mm	
		o	
		o	
		o	
Al		80kg/2u.	140x35 €/u
		8-10-12 mm	
		o	
Al	30x30	∞ 3445	€/u
PARA CARRIL AUTOPORTANTE			
		INOX BR NOX POL P.S.S. INOX LUC	NEGRO BLACK NERO
		22	0N
		∅ 60	€/u
		o	
		o	
		o	
Al	5 m	14x6	€/m
		∅ 6	
Al	100		€/u
		8-10 mm	
		o	
		o	
		inox s.s.	10 mm
		∞ 1856	€/u
		o	
		pvc	8-10 mm
		∞ 3488	€/m
		o	
		pvc	2,2 m
		8-10 mm	€/m
		o	
		o	

KITS

PLATA MATE
ALU. MAT
ALU. MATT
ALL. NATURALE
01

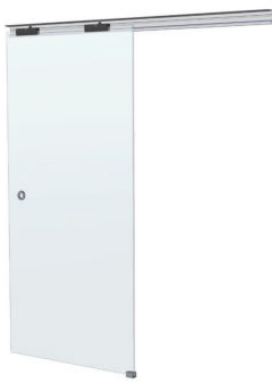

MONTAJE EMPOTRADO

KIT PORTE COULISSANTE ENCASTRÉ AU PLAFOND
KIT SLIDING DOOR RECESSED IN THE CEILING
KIT PORTA SCORREVOLE INCASSATA NEL SOFFITTO

3450/E21 1,93 m €/u
3450/E31 2,90 m €/u

CON AMORTIGUADOR, AVEC AMORTISSEURS,
WITH DUMPERS, CON AMORTIZZATORI

3445/201 - 3445/301 1 u. carril
3440/011 2 u. pinzas
+ amortiguador
4207/001 1 u. uñero

KITS

PLATA MATE
ALU. MAT
ALU. MATT
ALL. NATURALE
01

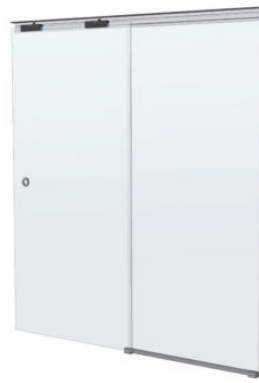

**MONTAJE EMPOTRADO
A TECHO + VIDRIO FIJO**

KIT PORTE COULISSANTE ENCASTRÉ AU PLAFOND + VERRE FIXE
KIT SLIDING DOOR RECESSED IN THE CEILING + FIXED GLASS
KIT PORTA SCORREVOLE INCASSATA NEL SOFFITTO + VETRO FISSO

3452/E21 1,93 m €/u
3452/E31 2,90 m €/u

CON AMORTIGUADOR, AVEC AMORTISSEURS,
WITH DUMPERS, CON AMORTIZZATORI

3445/201-3445/301 1 u. carril
4963/101-4963/201 1 u. perfil inf. vidrio fijo
3440/011 2 u. pinzas
+ amortiguador
4207/001 1 u. uñero

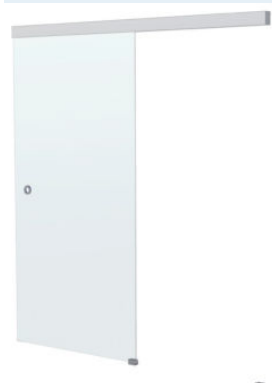

MONTAJE A PARED

KIT DE PORTE COULISSANTE FIXÉE AU MUR
KIT SLIDING DOOR FIXED TO THE WALL
KIT PORTA SCORREVOLE FISSATA A PARETE

3450/P21 1,93 m €/u
3450/P31 2,90 m €/u

CON AMORTIGUADOR, AVEC AMORTISSEURS,
WITH DUMPERS, CON AMORTIZZATORI

3445/201-3445/301 1 u. carril
3447/201-3447/301 1 u. tapa carril
3440/011 2 u. pinzas
4207/001 1 u. uñero



**MONTAJE A TECHO
+ VIDRIO FIJO**

KIT PORTE COULISSANTE FIXÉE AU PLAFOND + VERRE FIXE
KIT SLIDING DOOR FIXED TO THE CEILING + FIXED GLASS
KIT PORTA SCORREVOLE A SOFFITTO + VETRO FISSO

3452/T21 1,93 m €/u
3452/T31 2,90 m €/u

CON AMORTIGUADOR, AVEC AMORTISSEURS,
WITH DUMPERS, CON AMORTIZZATORI

3445/201-3445/301 1 u. carril
3447/201-3447/301 1 u. tapa carril
4963/101-4963/201 1 u. perfil inf. vidrio fijo
3440/011 2 u. pinzas
4207/001 1 u. uñero



MONTAJE A VIDRIO FIJO

KIT DE PORTE COULISSANTE FIXÉE AU MUR DE VERRE
KIT SLIDING DOOR FIXED TO THE GLASS-WALL
KIT PORTA SCORREVOLE FISSATA A PARETE DI VETRO

3450/V21 1,93 m €/u
3450/V31 2,90 m €/u

CON AMORTIGUADOR, AVEC AMORTISSEURS,
WITH DUMPERS, CON AMORTIZZATORI

3445/201-3445/301 1 u. carril
3447/201-3447/301 1 u. tapa carril
4961/201-4961/301 3 m. perfil anclaje vidrio fijo
3440/011 2 u. pinzas
4207/001 1 u. uñero

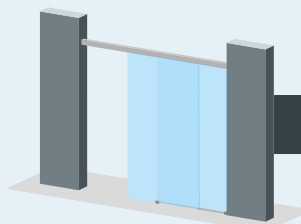

**AUTOPORTANTE
TAMBIÉN PARA DUCHAS**



**MONTAJE A PARED
LATERAL + VIDRIO FIJO**

KIT PORTE COULISSANTE FIXÉE AU PLAFOND + VERRE FIXE
KIT SLIDING DOOR FIXED TO THE CEILING + FIXED GLASS
KIT PORTA SCORREVOLE A SOFFITTO + VETRO FISSO

3453/L21 1,93 m €/u
3453/L31 2,90 m €/u

CON AMORTIGUADOR, AVEC AMORTISSEURS,
WITH DUMPERS, CON AMORTIZZATORI

3445/201-3445/301 1 u. carril
3447/201-3447/301 1 u. tapa carril
4963/101-4963/201 1 u. perfil inf. vidrio fijo
3440/011 2 u. pinzas
4207/001 1 u. uñero
3454/001 2 u. anclaje
carril-pared

CORREDERA KYOTO

- peso max. puerta: 120 kg/puerta
- vidrio 10-12 mm
- sin muesca en el vidrio
- pods-limite porte: 120 kg/porte
- verre 10-12 mm
- sans encoches
- weight max. door: 120 kg/door
- glass 10-12 mm
- without cut-out
- peso max. porta: 120 kg/porta
- vetro 10-12 mm
- senza tacca nel vidrio

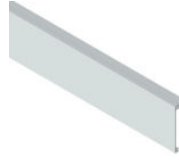
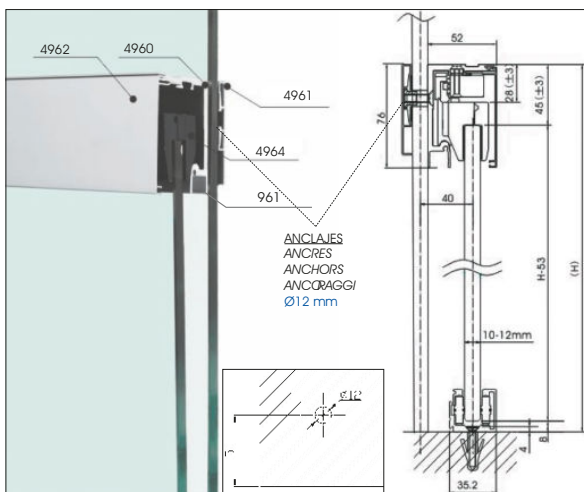
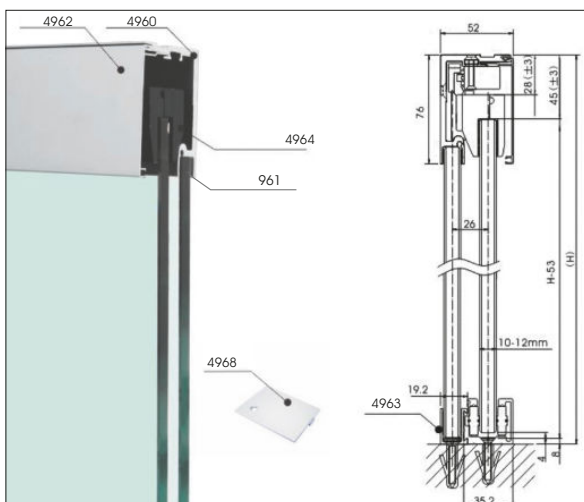
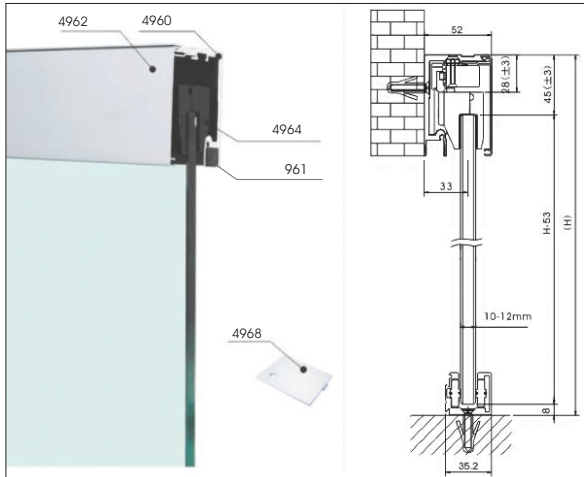

CARRIL
COULISSE HAUTE
UPPER TRACK
GUIDA SUPERIORE
4960/201 1,93 m
4960/301 2,90 m
4960/501 5,80 m

PERFIL TAPA CARRIL
PROFIL COUVERTURE COULISSE
TRACK COVER PROFIL
PROFILO COPERTINA GUIDA
4962/201 1,93 m
4962/301 2,90 m
4962/501 5,80 m

PERFIL INFERIOR VIDRIO FIJO
PROFIL INFERIEUR VERRE FIXE
BOTTOM PROFILE FIXED GLASS
PROFILO INFERIORE VETRO FISSO
Se acopla a 4964 y 4965
4963/101 0,96 m
4963/201 1,45 m
4963/301 2,90 m

PERFIL SOPORTE A PARED DE VIDRIO + 9 ANCLAJES
PROFIL SUPPORT MUR DE VERRE + 9 ANCRAS
PROFILE WALL-GLASS SUPPORT + 9 ANCHORS
PROFILO SUPPORTO A PARETE DI VETRO + 9 ANCORAGGI
4961/201 1,93 m
4961/301 2,90 m
4961/501 5,80 m

KIT PINZAS PORTAVIDRIO
KIT PINCE POUR VERRE
CLAMP FOR GLASS KIT
KIT PINZA PER VETRO

4964/011
CON AMORTIGUADORES
AVEC AMORTISSEURS
WITH DUMPERS
CON AMORTIZZATORI

Pinzas 2 u.
Guía Inferior 1 u.
Stop Suelo 1 u.

4970/011
SIN AMORTIGUADOR
SANS AMORTISSEURS
WITHOUT DUMPERS
SENZA AMORTIZZATORI

Pinzas 2 u.
Guía Inferior 1 u.
Stop Suelo 1 u.

REMATE FINAL CARRIL- GRIS
BOUCHON COULISSE- GRIS
END-CAP TRACK-GRAY
COPRITESTA TUBO - GRIGIO .
4968/001 SET 2U.

REMATE FINAL CARRIL- GRIS
BOUCHON COULISSE- GRIS
END-CAP TRACK-GRAY
COPRITESTA TUBO - GRIGIO .
4969/001 SET 2U.

ÚÑERO DOBLE ADHESIVO
POIGNÉE DOUBLE ADHESIVE
DOUBLE ADHESIVE PULL
POMO DOPPIO ADHESIVO
4207/0..
4207/0..

PERFIL TAPABOCAS
PROFIL COUVERTURE
COVER PROFIL
PROFILO COPRI-CANALE
*961/101

POMO
POIGNÉE
KNOB
POMO
4223/0..

CR. BR.LO	PL. M	BRUTO	PLÁSTICO
CH. POLI	ALL. M	BRUT	PLASTICU E
BR. CH	ALL. M	RAW	PLASTIC C
CR. LUC	ALL. NAT	GREZZO	PLASTICA
32	01	00	09
Al	5,8m	50x76	€/u
10-12 mm			
			o
			o
			o
Al	5,8m	74x24	€/u
			o
			o
			o
Al	5,8m	26x19,2	€/u
10-12 mm		∅ 4964-4965	
			o
			o
			o
Al	5,8m	70x7	€/u
∅ 12 mm			
			o
			o
			o
Al	120kg/2u.	180x43	€/u
10-12 mm			
			o
			o
			o
plac	52x76	∅ 4960 - 4962	€/u
			o
plac	52x76	∅ 4960 - 4962	€/u
			o
	∅ 60		€/u
			o
Al	5m	14x6	€/m
inox s.s.			
			o
			o
			o
			o
			o
Al	100		€/u
8-10 mm			
			o
			o

KITS

PLATA MATE
ALU. MATT
ALU. MATT
ALL. NATURALE
01

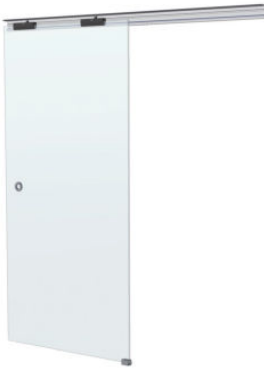

MONTAJE EMPOTRADO

KIT PORTE COULISSANTE ENCASTRÉ AU PLAFOND
KIT SLIDING DOOR RECESSED IN THE CEILING
KIT PORTA SCORREVOLE
INCASSATA NEL SOFFITTO

4957/E21 1,93 m ○ €/u
4957/E31 2,90 m ○ €/u

CON AMORTIGUADOR, AVEC AMORTISSEURS,
WITH DUMPERS, CON AMORTIZZATORI

4960/201 - 4960/301 1 u. carril
4964/001 KIT 2 u. pinza + amortiguador
1 u. "U" guía inferior
1 u. stop suelo
4207/001 1 u. uñero

4971/E21 1,93 m ○ €/u
4971/E31 2,90 m ○ €/u

SIN AMORTIGUADOR, SANS AMORTISSEURS,
WITHOUT DUMPERS, SENZA AMORTIZZATORI

4960/201 - 4960/301 1 u. carril
4970/001 KIT 2 u. pinzas
1 u. "U" guía inferior
1 u. stop suelo
4207/001 1 u. uñero

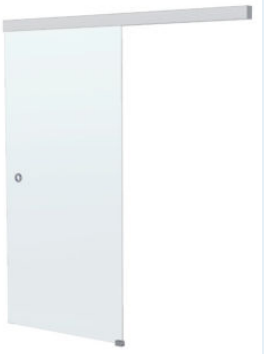

MONTAJE A PARED

KIT DE PORTE COULISSANTE FIXÉE AU MUR
KIT SLIDING DOOR FIXED TO THE WALL
KIT PORTA SCORREVOLE FISSATA A PARETE

4957/P21 1,93 m ○ €/u
4957/P31 2,90 m ○ €/u

CON AMORTIGUADOR, AVEC AMORTISSEURS,
WITH DUMPERS, CON AMORTIZZATORI

4960/201 - 4960/301 1 u. carril
4962/201 - 4262/301 1 u. tapa carril
4964/001 KIT 2 u. pinzas + amortiguador
1 u. "U" guía inferior
1 u. stop suelo
4968/009 1 u. tapa lateral
4207/001 1 u. uñero

4971/P21 1,93 m ○ €/u
4971/P31 2,90 m ○ €/u

SIN AMORTIGUADOR, SANS AMORTISSEURS,
WITHOUT DUMPERS, SENZA AMORTIZZATORI

4960/201 - 4960/301 1 u. carril
4962/101 3 m. tapa carril 3 m
4970/001 KIT 2 u. pinzas
1 u. "U" guía inferior
1 u. stop suelo
4968/009 1 u. tapa lateral
4207/001 1 u. uñero



MONTAJE A VIDRIO FIJO

KIT DE PORTE COULISSANTE FIXÉE AU MUR DE VERRE
KIT SLIDING DOOR FIXED TO THE GLASS WALL
KIT PORTA SCORREVOLE FISSATA A PARETE DI VETRO

4959/V21 1,93 m ○ €/u
4959/V31 2,90 m ○ €/u

CON AMORTIGUADOR, AVEC AMORTISSEURS,
WITH DUMPERS, CON AMORTIZZATORI

4960/201 - 4960/301 1 u. carril
4962/201 - 4262/301 1 u. tapa carril
4961/201 - 4961/301 1 u. perfil anclaje vidrio fijo
4964/001 KIT 2 u. pinzas + amortiguador
1 u. "U" guía inferior
1 u. stop suelo
4968/009 1 u. tapa lateral carril
4969/009 1 u. remate lateral
4207/001 1 u. uñero

4973/V21 1,93 m ○ €/u
4973/V31 2,90 m ○ €/u

SIN AMORTIGUADOR, SANS AMORTISSEURS,
WITHOUT DUMPERS, SENZA AMORTIZZATORI

4960/201 - 4960/301 1 u. carril
4962/201 - 4262/301 1 u. tapa carril
4961/201 - 4961/301 1 u. perfil anclaje vidrio fijo
4970/001 KIT 2 u. pinzas
1 u. "U" guía inferior
1 u. stop suelo
4968/009 1 u. tapa lateral carril
4969/009 1 u. remate lateral
4207/001 1 u. uñero

KITS

PLATA MATE
ALU. MATT
ALU. MATT
ALL. NATURALE
01

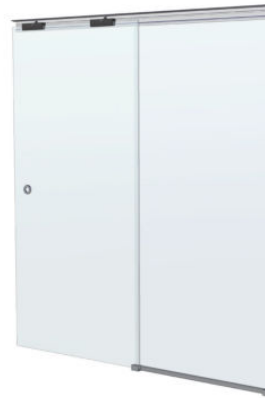

**MONTAJE EMPOTRADO
A TECHO + VIDRIO FIJO**

KIT PORTE COULISSANTE ENCASTRÉ AU PLAFOND + VERRE FIXE
KIT SLIDING DOOR RECESSED IN THE CEILING + FIXED GLASS
KIT PORTA SCORREVOLE INCASSATA NEL SOFFITTO + VETRO FISSO

4958/E21 1,93 m ○ €/u
4958/E31 2,90 m ○ €/u

CON AMORTIGUADOR, AVEC AMORTISSEURS,
WITH DUMPERS, CON AMORTIZZATORI

4960/201 - 4960/301 1 u. carril
4963/101 - 4963/201 1 u. perfil inf. vidrio fijo
4964/101 KIT 2 u. pinzas + amortiguador
1 u. "U" guía inferior
1 u. stop suelo
4207/001 1 u. uñero

4972/E21 1,93 m ○ €/u
4972/E31 2,90 m ○ €/u

SIN AMORTIGUADOR, SANS AMORTISSEURS,
WITHOUT DUMPERS, SENZA AMORTIZZATORI

4960/201 - 4960/301 1 u. carril
4963/101 - 4963/201 1 u. perfil inf. vidrio fijo
4970/001 KIT 2 u. pinzas
1 u. "U" guía inferior
1 u. stop suelo
4207/001 1 u. uñero



**MONTAJE A TECHO
+ VIDRIO FIJO**

KIT PORTE COULISSANTE FIXÉE AU PLAFOND + VERRE FIXE
KIT SLIDING DOOR FIXED TO THE CEILING + FIXED GLASS
KIT PORTA SCORREVOLE A SOFFITTO + VETRO FISSO

4958/T21 1,93 m ○ €/u
4958/T31 2,90 m ○ €/u

CON AMORTIGUADOR, AVEC AMORTISSEURS,
WITH DUMPERS, CON AMORTIZZATORI

4960/201 - 4960/301 1 u. carril
4962/201 - 4262/301 1 u. tapa carril
4963/101 - 4263/201 1 u. perfil inf. vidrio fijo
4964/001 KIT 2 u. pinzas + amortiguador
1 u. "U" guía inferior
1 u. stop suelo
4207/001 1 u. uñero

4972/T21 1,93 m ○ €/u
4972/T31 2,90 m ○ €/u

SIN AMORTIGUADOR, SANS AMORTISSEURS,
WITHOUT DUMPERS, SENZA AMORTIZZATORI

4960/201 - 4960/301 1 u. carril
4962/201 - 4262/301 1 u. tapa carril
4963/101 - 4263/201 1 u. perfil inf. vidrio fijo
4970/001 KIT 2 u. pinzas
1 u. "U" guía inferior
1 u. stop suelo
4207/001 1 u. uñero



*CORREDERA SERENA

- peso max. puerta:
80 kg/puerta
- vidrio 8-10-12 mm
- sin muesca en el vidrio

- pods-limite porte: 80 kg/porte
- verre 8-10-12 mm
- sans encoches
- weight max. door: 80 kg/door
- glass 8-10-12 mm
- without cut-out
- peso max. porta: 80 kg/porta
- vetro 8-10-12 mm
- senza tacca nel vetro

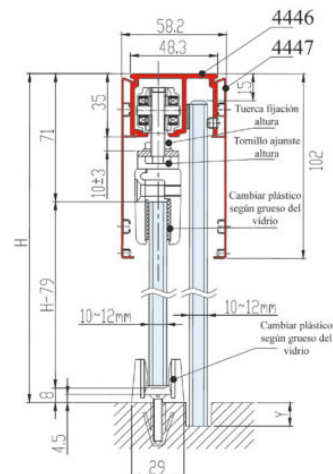
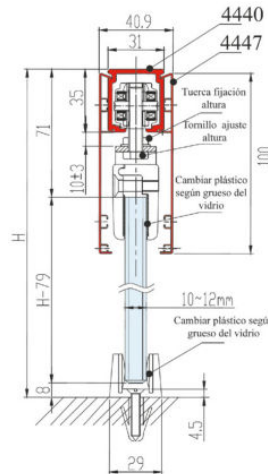
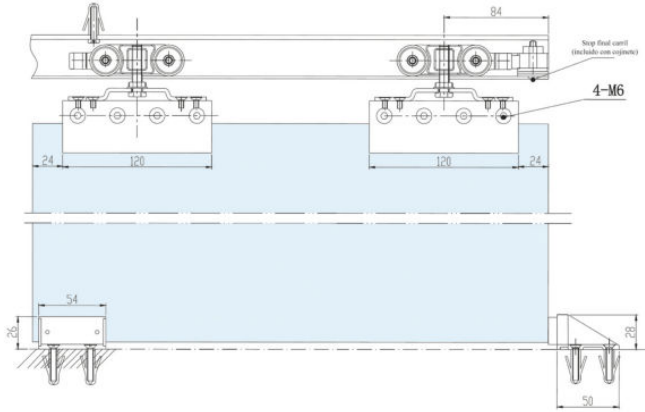
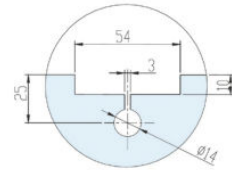

CR. BRILLO	PL. M	BRUTO
CR. POLI	ALU. M	BRUT
CR. CH	ALU. M	RAW
CR. LUC	ALL. NAT	GREZZO
32	01	00

Al	5,8m	31x35	€/u
----	------	-------	-----

CARRIL
COULISSE HAUTE
UPPER TRACK
GUIDA SUPERIORE

- *4445/201 1,93 m
- *4445/301 2,90 m
- *4445/501 5,80 m

Al	5,8m	48x35	€/u
----	------	-------	-----

CARRIL + VIDRIO FIJO
COULISSE HAUTE + VERRE FIXE
UPPER TRACK + FIXED GLASS
GUIDA SUP. + VETRO FISSO

- *4446/201 1,93 m
- *4446/301 2,90 m
- *4446/501 5,80 m

Al	5,8m	48x35	€/u
----	------	-------	-----

PERFIL TAPA CARRIL
PROFIL COUVERTURE COULISSE
TRACK COVER PROFIL
PROFILO COPERTINA GUIDA

- *4447/201 1,93 m
- *4447/301 2,90 m
- *4447/501 5,80 m

Al	5,8m	100x7	€/u
----	------	-------	-----

KIT PINZA PORTAVIDRIO
ALUMINIO
KIT PINCE POUR VERRE
CLAMP FOR GLASS KIT
KIT PINZA PER VETRO

- *4440/011
- Pinzas 2 u.
- Guía Inferior 1 u.

Al	inox s.s.	120x45	€/u
----	-----------	--------	-----

PERFIL TAPA CARRIL
PROFIL COUVERTURE COULISSE
TRACK COVER PROFIL
PROFILO COPERTINA GUIDA

- *4448/101

Al	3 m	48x7	€/m
----	-----	------	-----

KIT PINZA PORTAVIDRIO
ALUMINIO
KIT PINCE POUR VERRE
CLAMP FOR GLASS KIT
KIT PINZA PER VETRO

- *4441/011
- Pinzas 2 u.
- Guía Inferior 1 u.

Al	inox s.s.	120x45	€/u
----	-----------	--------	-----

GUÍA SUELO
GUIDAGE AU SOL
FLOOR GUIDE
GUIDA A PAVIMENTO

- *4442/001

Al	plas		€/u
----	------	--	-----

CR. BRILLO	PL. M	BRUTO	PLÁSTICO
CR. POLI	ALU. M	BRUT	PLÁSTICO E
CR. CH	ALU. M	RAW	PLÁSTIC
CR. LUC	ALL. NAT	GREZZO	PLÁSTICA
32	01	00	09

FIJACIÓN FRONTAL DEL CARRIL
FIXATION FRONTAL COULISSE
ASSEMBLY FITTING FOR TRACK
AGGANCIO FRONTALE GUIDA

- *4443/001

Al		€/u
----	--	-----

REMATE FINAL CARRIL- GRIS
BOUCHON COULISSE- GRIS
END-CAP TRACK-GRAY
COPRITESTA TUBO - GRIGIO

- *4444/009

plas	∞ 4445	€/u
------	--------	-----

REMATE FINAL CARRIL- GRIS
BOUCHON COULISSE- GRIS
END-CAP TRACK-GRAY
COPRITESTA TUBO - GRIGIO

- *4454/009

plas	∞ 4448	€/u
------	--------	-----

INOX BR	INOX SAT
P. S.S.	S. S.S.
INOX LUC	INOX SAT
22	28

UÑERO DOBLE ADHESIVO
POIGNEE DOUBLE ADHESIVE
DOUBLE ADHESIVE PULL
POMO DOPPIO ADHESIVO

- 4207/0..
- 4207/0..

∅ 60		€/u
------	--	-----

GALGA MONTAJE UÑEROS
GABARIT DE MONTAGE
INSTALLATION TOOL
SAGOMA AIUTO MONTAGGIO

- 4209/000

Al		€/u
----	--	-----

POMO
POIGNEE
KNOB
POMO

- 4223/0..

Al	100	€/u
----	-----	-----

KITS CORREDERA

PLATA MATE
ALU. MAT.
ALU. MATT
ALL. NATURALE
01

4450/E21 1,93 m
4450/E31 2,90 m
KIT PUERTA CORREDERA
EMPOTRABLE EN EL TECHO SIN MUESCA
KIT PORTE COULISSANTE ENCASTRÉ AU PLAFOND
KIT SLIDINGDOOR RECESSED IN THE CEILING
KIT PORTA SCORREVOLE INCASSATA NEL SOFFITTO
4445/101 2/3 m. carril
4440/011 KIT 2 u. pinzas
1 u. "U" guía inferior
4207/001 1 u. uñero



4451/E21 1,93 m
4451/E31 2,90 m
KIT PUERTA CORREDERA
EMPOTRABLE EN EL TECHO CON MUESCA
KIT PORTE COULISSANTE ENCASTRÉ AU PLAFOND
KIT SLIDINGDOOR RECESSED IN THE CEILING
KIT PORTA SCORREVOLE INCASSATA NEL SOFFITTO
4445/101 2/3 m. carril
4441/011 KIT 2 u. pinzas
1 u. "U" guía inferior
4207/001 1 u. uñero

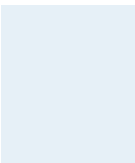

4450/P21 1,93 m
4450/P31 2,90 m
KIT PUERTA CORREDERA A PARED SIN MUESCA
KIT DE PORTE COULISSANTE FIXÉE AU MUR
KIT SLIDINGDOOR FIXED TO THE WALL
KIT PORTA SCORREVOLE FISSATA A PARETE
4445/201-4445/301 1 u. carril
4447/201-4447/301 1 u. tapa carril
4440/011 KIT 2 u. pinzas
1 u. "U" guía inferior
4443/001 5 u. enganche pared
4444/009 2 u. tapa lateral
4207/001 1 u. uñero



4451/P21 1,93 m
4451/P31 2,90 m
KIT PUERTA CORREDERA A PARED CON MUESCA
KIT DE PORTE COULISSANTE FIXÉE AU MUR
KIT SLIDINGDOOR FIXED TO THE WALL
KIT PORTA SCORREVOLE FISSATA A PARETE
4445/201-4445/301 1 u. carril
4441/011 KIT 2 u. pinzas
1 u. "U" guía inferior
4443/001 5 u. enganche pared
4444/009 2 u. tapa lateral
4207/001 1 u. uñero

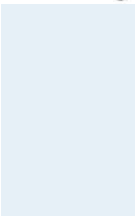

4450/T21 1,93 m
4450/T31 2,90 m
KIT PUERTA CORREDERA A TECHO
SIN MUESCA
KIT PORTE COULISSANTE FIXÉ AU PLAFOND
KIT SLIDINGDOOR FIXED TO THE CEILING
KIT PORTA SCORREVOLE A SOFFITTO
4445/201-4445/301 1 u. carril
4447/201-4447/301 2 u. tapa carril
4440/011 KIT 2 u. pinzas
1 u. "U" guía inferior
4207/001 1 u. uñero



4451/T21 1,93 m
4451/T31 2,90 m
KIT PUERTA CORREDERA A TECHO
CON MUESCA
KIT PORTE COULISSANTE FIXÉ AU PLAFOND
KIT SLIDINGDOOR FIXED TO THE CEILING
KIT PORTA SCORREVOLE A SOFFITTO
4445/201-4445/301 1 u. carril
4447/201-4447/301 2 u. tapa carril
4441/011 KIT 2 u. pinzas
1 u. "U" guía inferior
4207/001 1 u. uñero

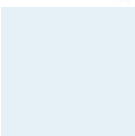

KITS CORREDERA + FIJO

PLATA MATE
ALU. MAT.
ALU. MATT
ALL. NATURALE
01

4452/E21 1,93 m
4452/E31 2,90 m
KIT PUERTA CORREDERA
EMPOTRABLE A TECHO + VIDRIO FIJO
SIN MUESCA
KIT PORTE COULISSANTE ENCASTRÉ
AU PLAFOND + VERRE FIXE
KIT SLIDINGDOOR RECESSED
IN THE CEILING + FIXED GLASS
KIT PORTA SCORREVOLE INCASSATA
NEL SOFFITTO + VETRO FISSO
4446/201-4446/301 1 u. carril
4440/011 KIT 2 u. pinzas
1 u. "U" guía inferior
4207/001 1 u. uñero

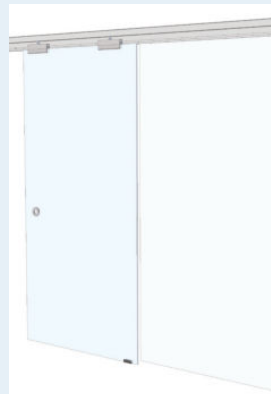

4453/E21 1,93 m
4453/E31 2,90 m
KIT PUERTA CORREDERA
EMPOTRABLE A TECHO + VIDRIO FIJO
CON MUESCA
KIT PORTE COULISSANTE ENCASTRÉ
AU PLAFOND + VERRE FIXE
KIT SLIDINGDOOR RECESSED
IN THE CEILING + FIXED GLASS
KIT PORTA SCORREVOLE INCASSATA
NEL SOFFITTO + VETRO FISSO
4446/201-4446/301 1 u. carril
4441/011 KIT 2 u. pinzas
1 u. "U" guía inferior
4207/001 1 u. uñero

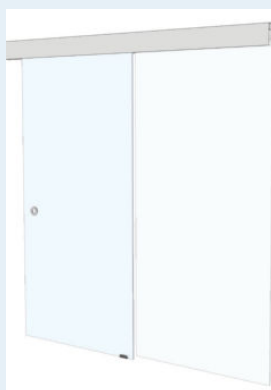

4452/T21 1,93 m
4452/T31 2,90 m
KIT PUERTA CORREDERA
A TECHO + VIDRIO FIJO
SIN MUESCA
KIT PORTE COULISSANTE FIXÉ
AU PLAFOND + VERRE FIXE
KIT SLIDINGDOOR FIXED
TO THE CEILING + FIXED GLASS
KIT PORTA SCORREVOLE
A SOFFITTO + VETRO FISSO
4446/201-4446/301 1 u. carril
4447/201-4447/301 2 u. tapa carril
4440/011 KIT 2 u. pinzas
1 u. "U" guía inferior
4207/001 1 u. uñero

4453/T21 1,93 m
4453/T31 2,90 m
KIT PUERTA CORREDERA
A TECHO + VIDRIO FIJO
CON MUESCA
KIT PORTE COULISSANTE FIXÉ
AU PLAFOND + VERRE FIXE
KIT SLIDINGDOOR FIXED
TO THE CEILING + FIXED GLASS
KIT PORTA SCORREVOLE
A SOFFITTO + VETRO FISSO
4446/201-4446/301 1 u. carril
4447/201-4447/301 2 u. tapa carril
4441/011 KIT 2 u. pinzas
1 u. "U" guía inferior
4207/001 1 u. uñero

*CORREDERA SYNCRO

- peso max. puerta: 80 kg/puerta
- vidrio 8-12 mm
- sin muesca en el vidrio
- 2 puertas sincronizadas
- peso max. porta: 80 kg/porta
- vetro 8-12 mm
- senza tacca nel vetro
- 2 porte sincronizzate
- pods-limite porte: 80 kg/porte
- verre 8-12 mm
- sans encoches
- 2 portes synchronisées
- weight max. door: 80 kg/door
- glass 8-12 mm
- without cut-out
- 2 synchronized doors

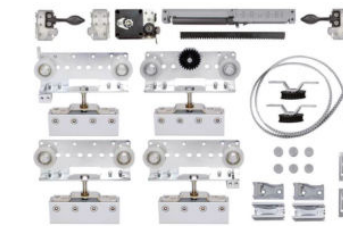
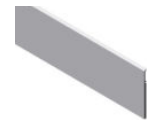
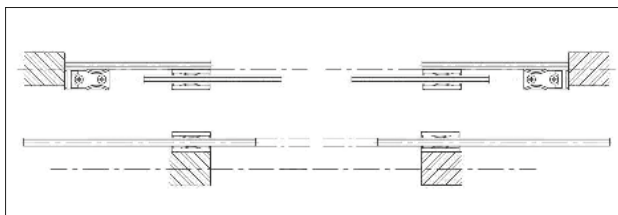
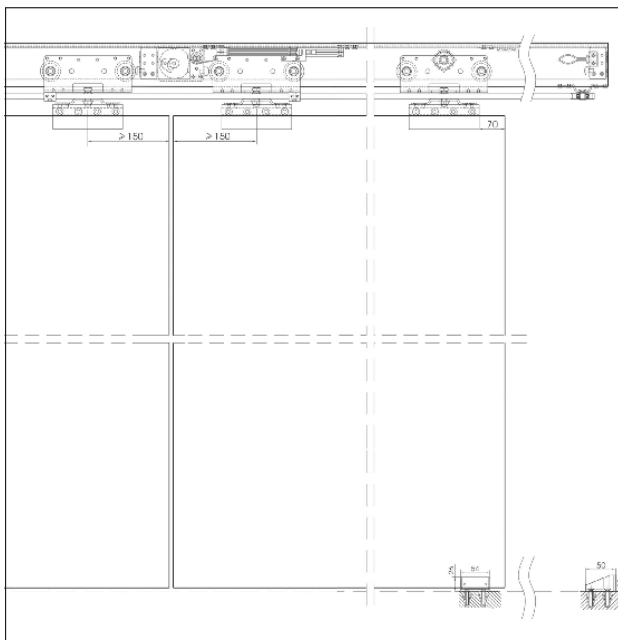
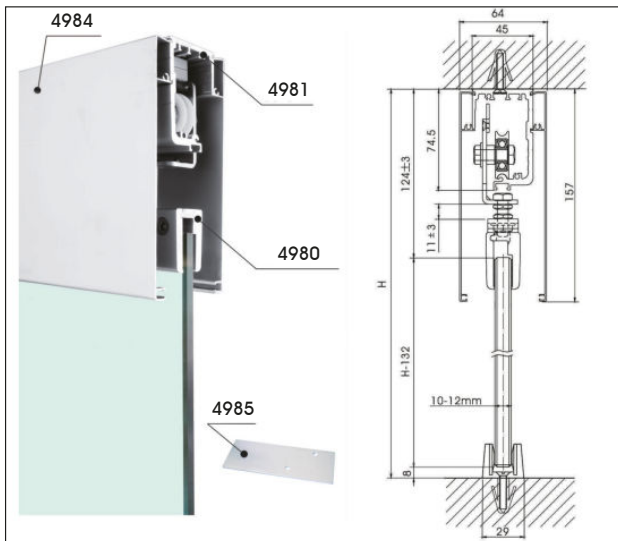

CARRIL
COULISSE HAUTE
UPPER TRACK
GUIDA SUPERIORE
*4981/401

PERFIL SUPERIORVIDRIO FIJO
PROFIL SUPERIEUR VERRE FIXE
UPPE PROFILE FIXED GLASS
PROFILO ISUPERIORE VETROFISSO
4982/401

PERFIL SOPORTE A PARED
DE VIDRIO + ANCLAJES
PROFIL SUPPORT MUR DE
VERRE + ANCRÉS
PROFILE WALL-GLASS SUPPORT
+ ANCHORS
PROFILO SUPPORTO APARETE
DI VETRO + ANCORAGG
*4983/401

PERFIL TAPA CARRIL
PROFIL COUVERTURE COULISSE
TRACK COVER PROFIL
PROFILO COPERTINA GUIDA
4984/401

REMATE FINAL CARRIL- GRIS
BOUCHON COULISSE- GRIS
END-CAP TRACK-GRAY
COPRITESTA TUBO - GRIGIO .
*4985/009

KIT PINZAS 2 PUERTAS
SINCRONIZADAS
KIT 2 PINCES 2 PORTES SYNCRONIZÉE
KIT CLAMPS 2 SYNCRONIZED DOORS
KIT PINZE PER 2 PORTE SINCRONIZZATE
*4980/001

UÑERO DOBLE ADHESIVO
POIGNÉE DOUBLE ADHESIVE
DOUBLE ADHESIVE PULL
POMO DOPPIO ADHESIVO
4207/0..
4207/0..

GALGA MONTAJE UÑEROS
GABARIT DE MONTAGE
INSTALLATION TOOL
SAGOMA AIUTO MONTAGGIO
4209/000

POMO
POIGNÉE
KNOB
POMO
4223/0..

CR. BRILLO CHR. POLI BR. CHR. CR. LUC.	PL. M ALU. M ALL. NAT.	BRUTO BRUT RAW GREZZO	PLÁSTICO PLASTIGU E PLASTIC PLASTICA
32	01	00	09

Al	4 m	74,5x45	€/u
----	-----	---------	-----

			*o
--	--	--	----

Al	4 m	∞ 4981-4984	€/u
	8-12 mm		

			o
--	--	--	---

Al	4 m		€/u
----	-----	--	-----

			*o
--	--	--	----

Al	4 m	157x10	€/u
		∞ 4981-4982	

			o
--	--	--	---

plac	157x55	∞ 4981- 4984	€/u
------	--------	--------------	-----

			*o
--	--	--	----

Al	80kg/2u.	120x45	€/u
----	----------	--------	-----

			*o
--	--	--	----

INOX BR NOX POLI P.S.S. INOX LUC	INOX SAT INOX SAT S.S.S. INOX SAT
22	28

∅ 60			€/u
------	--	--	-----

Al			o
inox S.S.			o

Al			€/u
----	--	--	-----

			o
--	--	--	---

Al	100		€/u
	8-10 mm		

			o
--	--	--	---

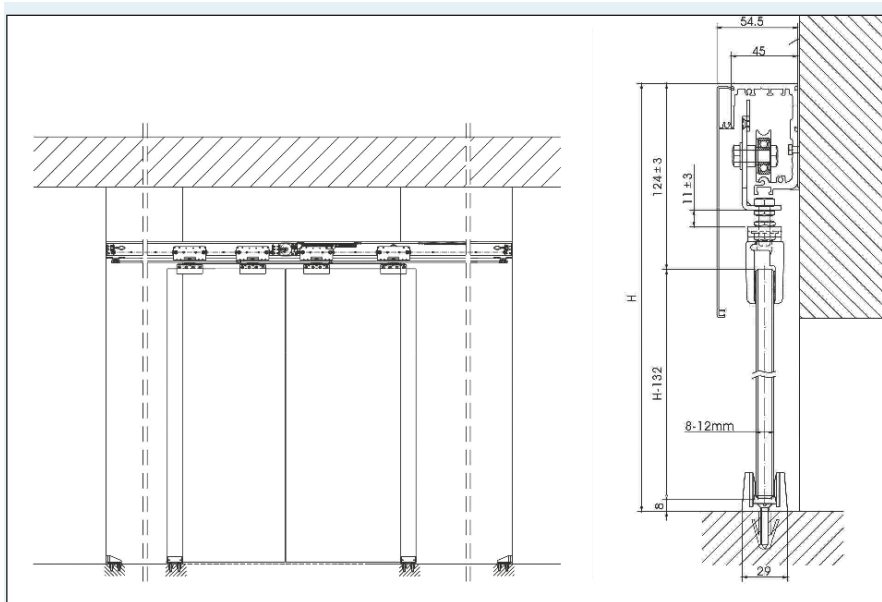

KITS

MONTAJE A PARED

4986/001 €/U

KIT PUERTA CORREDERA A PARED
KIT DE PORTE COULISSANTE FIXÉE AU MUR
KIT SLIDING DOOR FIXED TO THE WALL
KIT PORTA SCORREVOLE FISSATA APARETE

4981/401 1 u. carril 4 m
4984/401 1 u. tapa frontal 4 m
4980/001 1 u. kit pinzas
4985/001 2 u. tapa final
4207/001 2 u. uñero

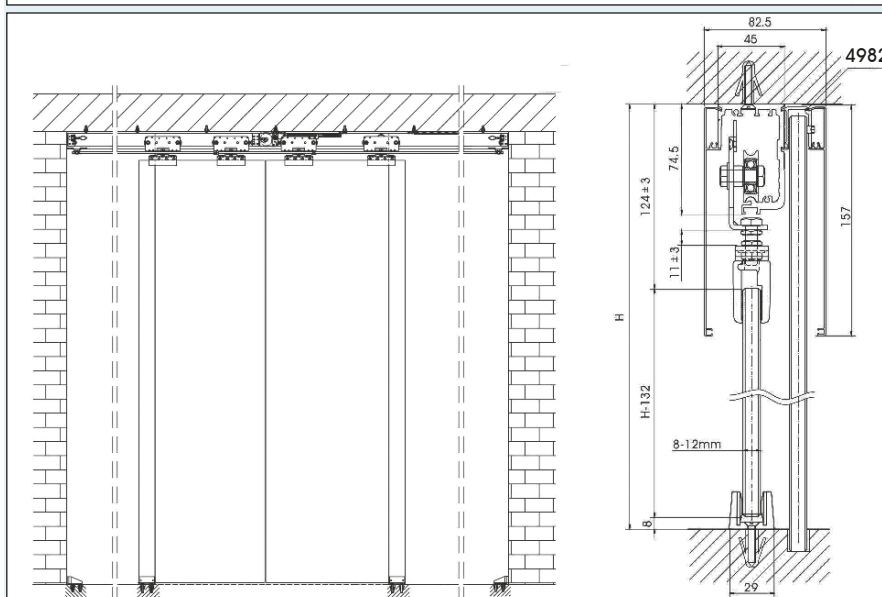

MONTAJE A TECHO

4987/001 €/U

KIT PUERTA CORREDERA A TECHO
KIT PORTE COULISSANTE FIXÉE AU PLAFOND
KIT SLIDING DOOR FIXED TO THE CEILING
KIT PORTA SCORREVOLE A SOFFITTO

4981/401 1 u. carril 4 m
4982/401 1 u. perfil superior vidrio fijo 4 m
4984/401 2 u. tapa frontal 4 m
4980/001 1 u. kit pinzas
4207/001 2 u. uñero

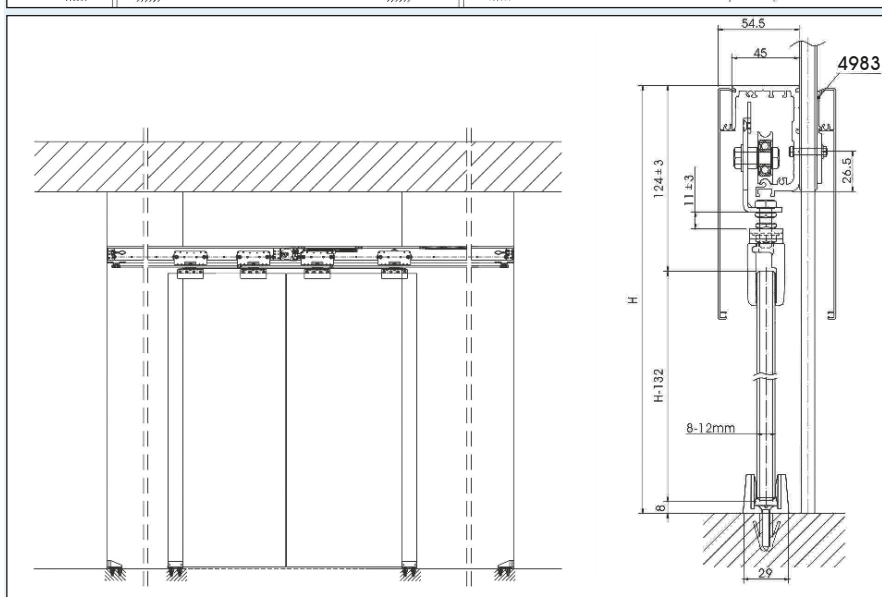

MONTAJE A VIDRIO FIJO

4988/001 €/U

KIT PUERTA CORREDERA A VIDRIO FIJO
KIT DE PORTE COULISSANTE FIXÉE AU MUR DE VERRE
KIT SLIDING DOOR FIXED TO THE GLASS-WALL
KIT PORTA SCORREVOLE FISSATA APARETE DI VETRO

4981/401 1 u. carril 4 m
4983/401 4 u. perfil soporte vidrio fijo 4 m
4984/401 2 u. tapa frontal 4 m
4980/001 1 u. kit pinzas
4985/001 2 u. tapa final
4207/001 2 u. uñero

TELEX 2 PUERTA CORREDERA
TELESCÓPICA DE VIDRIO

- peso max. puerta: 80 kg/puerta
 - vidrio 8-12 mm
 - sin muesca en el vidrio
 - 1 fijo + 2 correderas
- peso max. porta: 80 kg/porta
 - vetro 8-12 mm
 - senza tacca nel vetro
 - 1 vetro fisso + 2 porte scorrevoli
- poids-limite porte: 80 kg/porte
 - verre 8-12 mm
 - sans encoches
 - 1 verre fixe + 2 portes coulissantes
- weight max. door: 80 kg/door
 - glass 8-12 mm
 - without cut -out
 - 1 fixed glass+ 2 sliding doors

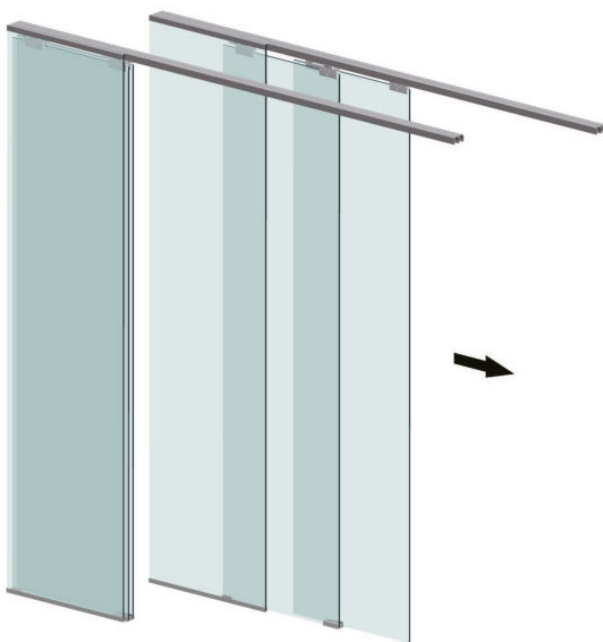

SET BASE

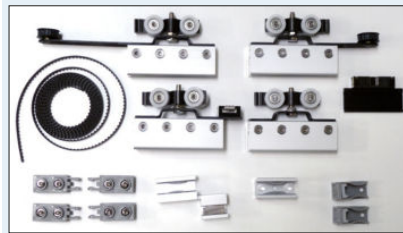

CR. BRILLO CHR. POLI BR. CHR CR. LUC	PL. M ALU. M ALU. M ALL. NAT	BRUTO RAW RAW GREZZO	PLÁSTICO PLASTIGU E PLASTIC PLASTICA
32	01	00	09

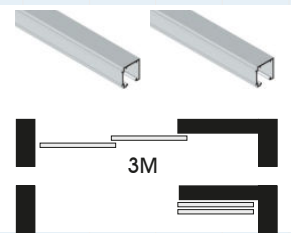

KIT PUERTA TELESCÓPICA 3 m 2 CORREDERAS
2 PERFILES DE ALUMINIO + ACCESORIOS PARA
2 PUERTAS TELESCÓPICAS

SET PORTE TÉLESCOPIQUE 3 m 2 PORTES COULISSANTES
2 ALUMINIUM PERFILES + ACCESSOIRES POUR
2 PORTES TÉLESCOPIQUES

SET TELESCOPIC DOOR 3 m 2 SLIDING DOORS
2 ALUMINIUM PROFILS 3 m + ACCESSORIES FOR
2 TELESCOPIC DOORS

SET PORTE TELESCOPICHE 3 m 2 PORTES SCORREVOLI
2 PROFILI DI ALLUMINIO + ACCESSORI PER
2 PORTE TELESCOPICHE

4990/001 KIT BASE
KIT PORTE COULISSANTE
KIT SLIDINGDOOR
KIT PORTA SCORREVOLE

Al	3 m	∞ 4983-4994	€/u
----	-----	-------------	-----



PERFIL SUPERIOR VIDRIO FIJO
PROFIL SUPERIEUR VERRE FIXE
UPPE PROFILE FIXED GLASS
PROFILO SUPERIORE VETRO FISSO
4982/401

Al	4 m	∞ 4990-4984	€/u
	8-12 mm		

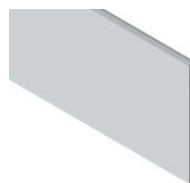

PERFIL TAPA CARRIL
PROFIL COUVERTURE COULISSE
TRACK COVER PROFIL
PROFILO COPERTINA GUIDA
4984/401

Al	4 m	157x10	€/u
	∞ 4983-4900		

INOX BR INOX POLI P.S.S.	INOX SAT INOX SAT S.S.S.	INOX SAT INOX SAT
22	28	



UÑERO DOBLE ADHESIVO
POIGNÉE DOUBLE ADHESIVE
DOUBLE ADHESIVE PULL
POMO DOPPIO ADHESIVO
4207/0..
4207/0..

	∅ 60		€/u
--	------	--	-----

Al			
INOX S.S.			



GALGA MONTAJE UÑEROS
GABARIT DE MONTAGE
INSTALLATION TOOL
SAGOMA AIUTO MONTAGGIO
4209/000

Al			€/u
----	--	--	-----



POMO
POIGNÉE
KNOB
POMO
4223/0..

Al	100		€/u
	8-10 mm		

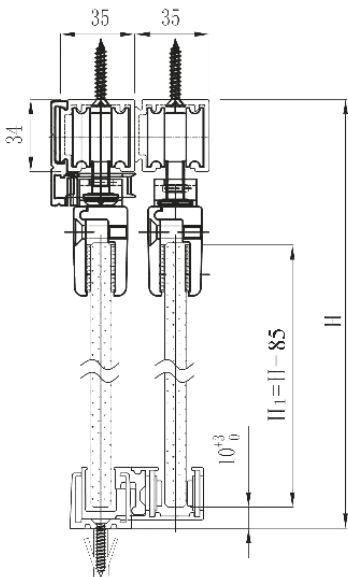
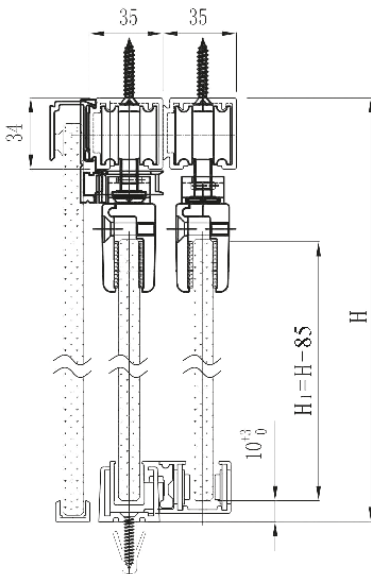
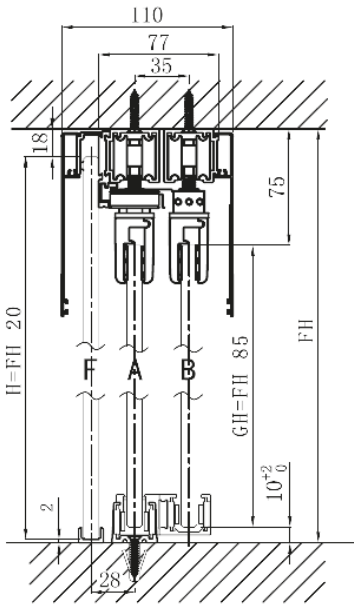

KITS

PL.M
ALU.M
ALU.M
ALL.NAT
01

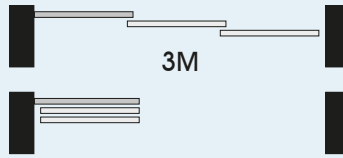

SET PUERTA TELESCÓPICA 3 m 1 FIJO + 2 CORREDERAS
PERFILES DE ALUMINIO + ACCESORIOS PARA 2 PUERTAS TELESCÓPICAS
SET PORTE TÉLESCOPIQUE 3 m 1 FIXE + 2 PORTES COULISSANTES
ALUMINIUM PERFILES + ACCESSOIRES POUR 2 PORTES TÉLESCOPIQUES
SET TELESCOPIC DOOR 3 m 1 FIXED + 2 SLIDING DOORS
ALUMINIUM PROFILS 3 m + ACCESSORIES FOR 2 TELESCOPIC DOORS
SET PORTE TELESCOPICHE 3 m 1 FISSO + 2 PORTES SCORREVOLI
PROFILI DI ALLUMINIO + ACCESSORI PER 2 PORTE TELESCOPICHE

4990/T01 KIT 4990 + 4982 + 2 TAPAS LATERALES 4984
KIT PORTE COULISSANTE + 2 PROFILS COUVERTURE COULISSE 4982
KIT SLIDING DOOR + TRACK COVER PROFIL 4982
KIT PORTA SCORREVOLE + PROFILO COPERTINA GUIDA 4982

SET PUERTA TELESCÓPICA 3 m 1 FIJO + 2 CORREDERAS
PERFILES DE ALUMINIO + ACCESORIOS PARA 2 PUERTAS TELESCÓPICAS
SET PORTE TÉLESCOPIQUE 3 m 1 FIXE + 2 PORTES COULISSANTES
ALUMINIUM PERFILES + ACCESSOIRES POUR 2 PORTES TÉLESCOPIQUES
SET TELESCOPIC DOOR 3 m 1 FIXED + 2 SLIDING DOORS
ALUMINIUM PROFILS 3 m + ACCESSORIES FOR 2 TELESCOPIC DOORS
SET PORTE TELESCOPICHE 3 m 1 FISSO + 2 PORTES SCORREVOLI
PROFILI DI ALLUMINIO + ACCESSORI PER 2 PORTE TELESCOPICHE

4990/E01 KIT 4990 + 4982 EMPOTRADO EN EL TECHO
KIT PORTE COULISSANTE ENCASTRÉ AU PLAFOND
KIT SLIDING DOOR RECESSED IN THE CEILING
KIT PORTA SCORREVOLE INCASSATA NEL SOFFITTO

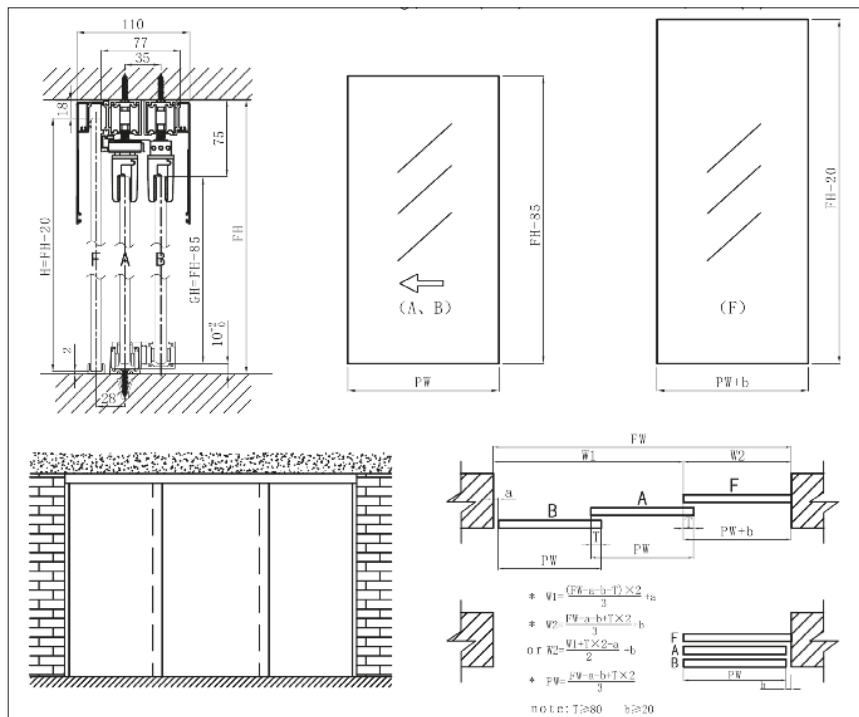

TELEX 3 PUERTA CORREDERA TELESCÓPICA DE VIDRIO

- peso max. puerta: 80 kg/puerta
- vidrio 8-12 mm
- sin muesca en el vidrio
- 1 fijo + 3 correderas

- peso max. puerta: 80 kg/puerta
- vidrio 8-12 mm
- senza tacca nel vetro
- 1 vetro fisso + 3 porte scorrevoli

- poids-limite porte: 80 kg/porte
- verre 8-12 mm
- sans encoches
- 1 verre fixe + 3 portes coulissantes
- weight max. door: 80 kg/door
- glass 8-12 mm
- without cut -out
- 1 fixed glass+ 3 sliding doors

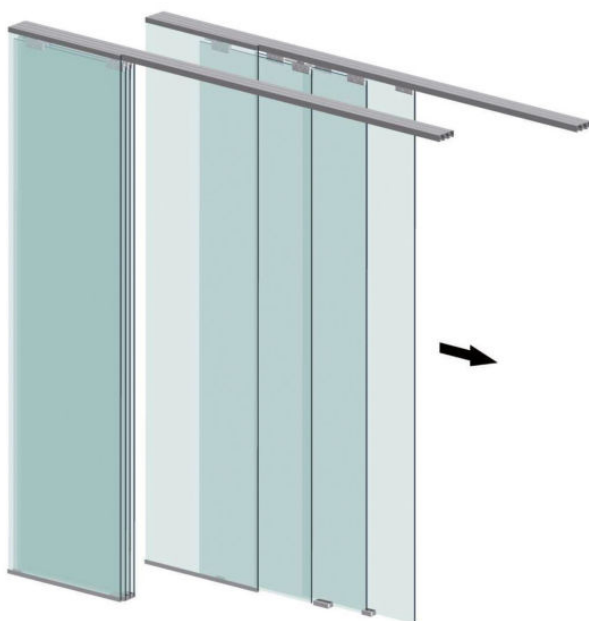

SET BASE

CR. BRILLO CHR. POLI BR. CHR CR. LUC	PL. M ALU. M ALU. M ALL. NAT	BRUTO BRUT RAW GREZZO	PLÁSTICO PLASTIQUE PLASTIC PLASTICA
32	01	00	09

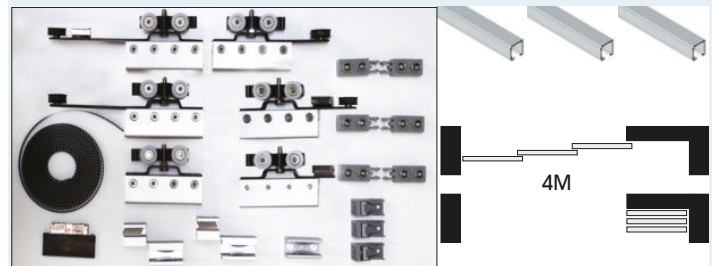

KIT PUERTA TELESCÓPICA 4 m 3 CORREDERAS
3 PERFILES DE ALUMINIO + ACCESORIOS PARA
3 PUERTAS TELESCÓPICAS

SET PORTE TÉLESCOPIQUE 4 m 3 PORTES COULISSANTES
3 ALUMINIUM PERFILES + ACCESSOIRES POUR
3 PORTES TÉLESCOPIQUES

SET TELESCOPIC DOOR 4 m 3 SLIDING DOORS
3 ALUMINIUM PROFILES 3 m + ACCESSORIES FOR
3 TELESCOPIC DOORS

SET PORTE TELESCOPICHE 4 m 3 PORTES SCORREVOLI
3 PROFILI DI ALUMINIO + ACCESSORI PER
3 PORTE TELESCOPICHE

Al		4 m	∞	4983-4994	€/U
----	--	-----	---	-----------	-----

4991/001 KIT BASE
KIT PORTE COULISSANTE
KIT SLIDINGDOOR
KIT PORTA SCORREVOLE

	PERFIL SUPERIORVIDRIO FIJO PROFIL SUPERIEUR VERRE FIXE UPPE PROFILE FIXED GLASS PROFILO SUPERIORE VETRO FISSO 4982/401	Al		4 m	∞	4990-4984	€/U	
	PERFIL TAPA CARRIL PROFIL COUVERTURE COULISSE TRACK COVER PROFIL PROFILO COPERTINA GUIDA 4984/401	Al		4 m	157x10	∞	4983-4900	€/U
	UÑERO DOBLE ADHESIVO POIGNEÉ DOUBLE ADHESIVE DOUBLE ADHESIVE PULL POMO DOPPIO ADHESIVO 4207/0.. 4207/0..	Al		∅ 60			€/U	
	GALGA MONTAJE UÑEROS GABARIT DE MONTAGE INSTALLATION TOOL SAGOMA AIUTO MONTAGGIO 4209/000	Al					€/U	
	POMO POIGNEÉ KNOB POMO 4223/0..	Al		100			€/U	

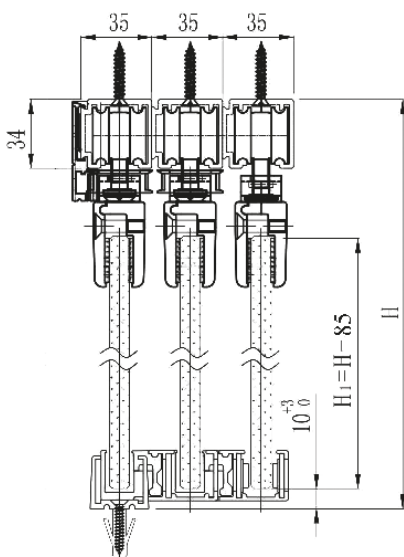
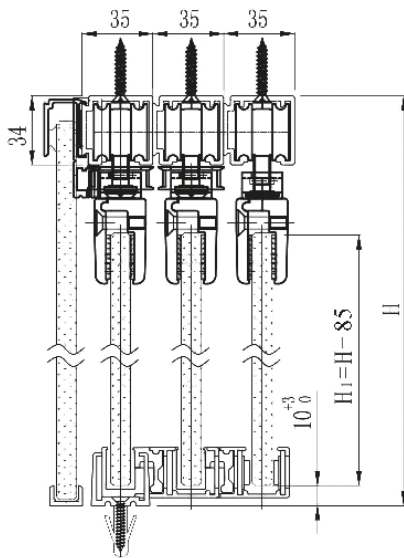
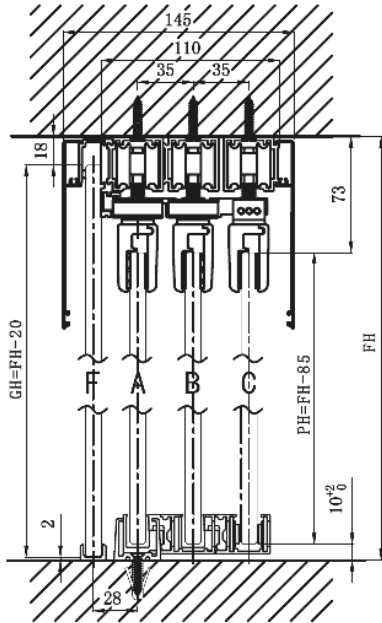

KITS

PL.M
ALU.M
ALU.M
ALL.NAT
01

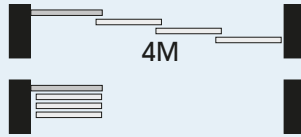

SET PUERTA TELESCÓPICA 4 m 1 FIJO + 3 CORREDERAS.
PERFILES DE ALUMINIO + ACCESORIOS PARA 3 PUERTAS TELESCÓPICAS
SET PORTE TÉLESCOPIQUE 4 m 1 FIXE + 3 PORTES COULISSANTES
ALUMINIUM PERFILES + ACCESSOIRES POUR 3 PORTES TÉLESCOPIQUES
SET TELESCOPIC DOOR 4 m 1 FIXED + 3 SLIDING DOORS
ALUMINIUM PROFILS + ACCESSOIRES FOR 3 TELESCOPIC DOORS
SET PORTE TELESCOPICHE 4 m 1 FISSO + 3 PORTES SCORREVOLI
PROFILI DI ALLUMINIO + ACCESSORI PER 3 PORTE TELESCOPICHE

4991/T01 KIT 4991 + 4982 + 2 TAPAS LATERALES 4984
KIT PORTE COULISSANTE + 2PROFILES COUVERTURE COULISSE 4982
KIT SLIDINGDOOR +TRACK COVER PROFIL 4982
KIT PORTASCORREVOLE +PROFILO COPERTINA GUIDA 4982

SET PUERTA TELESCÓPICA 4 m 1 FIJO + 3 CORREDERAS.
PERFILES DE ALUMINIO + ACCESORIOS PARA 3 PUERTAS TELESCÓPICAS
SET PORTE TÉLESCOPIQUE 4 m 1 FIXE + 3 PORTES COULISSANTES
ALUMINIUM PERFILES + ACCESSOIRES POUR 2 PORTES TÉLESCOPIQUES
SET TELESCOPIC DOOR 4 m 1 FIXED + 3 SLIDING DOORS
ALUMINIUM PROFILS + ACCESSOIRES FOR 3 TELESCOPIC DOORS
SET PORTE TELESCOPICHE 4 m 1 FISSO + 3 PORTES SCORREVOLI
PROFILI DI ALLUMINIO + ACCESSORI PER 3 PORTE TELESCOPICHE

4991/E01 KIT 4991 + 4982 EMPOTRADO EN EL TECHO
KIT PORTE COULISSANTE ENCASTRÉ AU PLAFOND
KIT SLIDINGDOOR RECESSED IN THE CEILING
KIT PORTASCORREVOLE INCASSATA NEL SOFFITTO

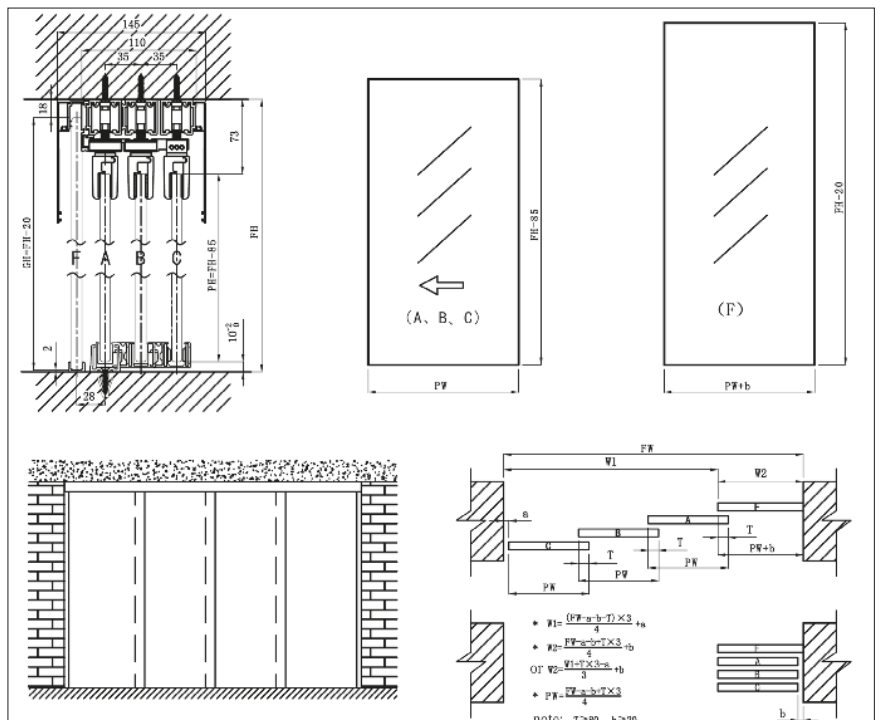

CORREDERA PLATEK

- peso max. puerta: 100 kg/puerta
- vidrio 10-12 mm
- 100 kg/porte 100 kg/door 100 kg/porta
- verre 10-12 mm glass 10-12 mm vetro 10-12 mm



ANCLAJE CARRIL-PARED
FIXATION MUR-COULISSE
CONNEXION WALL-TRACK
CONNESSIONE PARETE-GUIDA
4355/028

PLÁSTICO PLASTIQUE PLASTIC PLASTICA	INOX SAT INOX SAT S.S.S. INOX SAT	ZINCADO PL. ZNK ZNK PL. ZINCATO
09	28	34

inox s.s.	Ø 25		€/u
-----------	------	--	-----



CONEXIÓN TUBO-PARED
FIXATION TUBE-MUR
CONNEXION TUBE-WALL
CONNESSIONE TUBO-PARETE
4353/028

inox s.s.	Ø 25		€/u
-----------	------	--	-----



TALADRO NO AVELLANADO
TROU NOT FRAISÉE
DRILL NO COUNTERSINK
FORO NON SVASATO

ANCLAJE VID.FIJO-CARRIL
FIXATION VERRE-COULISSE
CONNEXION GLASS-TRACK
CONNESSIONE VETRO-GUIDA
5354/028

inox s.s.	10-12mm	Ø 25	€/u
	Ø 26 mm		



UÑERO DOBLE ADHESIVO
POIGNEÉ DOUBLE ADHESIVE
DOUBLE ADHESIVE PULL
POMO DOPPIO ADHESIVO
4207/0..

inox s.s.	Ø 60		€/u
-----------	------	--	-----



GALGA MONTAJE UÑEROS
GABARIT DE MONTAGE
INSTALLATION TOOL
SAGOMA AIUTO MONTAGGIO
4209/000

Al			€/u
----	--	--	-----



UÑERO POIGNEÉ
KNOB
POMO
4322/028

inox s.s.	8-12 mm		€/u
	Ø 50 mm		



UÑERO POIGNEÉ
KNOB
POMO
4337/028

inox s.s.	8-12 mm		€/u
	Ø 46 mm		



CONEXIÓN TUBO-TECHO
FIXATION TUBE-PLAFOND
CONNEXION TUBE-CEILING
CONNESSIONE TUBO-SOFFITTO
***4363/028**

inox s.s.	Ø 25		€/u
-----------	------	--	-----



LLAVE REGULABLE x TORNILLO
OUTIL RÉGLABLE x VIS
ADJUSTABLE TOOL x SCREWS
UTENSILE REGOLABILE x VITI
4398/034

inox s.s.	Ø 25		€/u
-----------	------	--	-----



COJINETE CHARLOT
ROLLER
CUSCINETTO
5362/028 plano

TALADRO NO AVELLANADO
TROU NOT FRAISÉE
DRILL NO COUNTERSINK
FORO NON SVASATO

PLÁSTICO PLASTIQUE PLASTIC PLASTICA	INOX SAT INOX SAT S.S.S. INOX SAT	ZINCADO PL. ZNK ZNK PL. ZINCATO
09	28	34

inox s.s.	10-12mm	50kg/u	€/u
	Ø 26 mm		



TUBO-CARRIL
TUBE-COULISSE
TUBE-TRACK
TUBO-GUIDA
4350/328 3 m
4350/228 2 m

inox s.s.	2/3 m	Ø25x2,5	€/u
-----------	-------	---------	-----



REMATE FINAL CARRIL
BOUCHON COULISSE
END-CAP TRACK
COPRITESTA TUBO
236/028

Ø 25			€/u
------	--	--	-----



GUÍA SUELO
GUIDAGE AU SOL
FLOOR GUIDE
GUIDA A PAVIMENTO
4352/028

inox s.s.	10-12 mm		€/u
-----------	----------	--	-----



STOP COJINETE
STOP CHARLOT
STOP ROLLER
STOP CUSCINETTO
5356/028 DERECHA
droite/right/destra
5357/028 IZQUIERDA
gauche/left/sinistra

inox s.s.	Ø 25		€/u
-----------	------	--	-----

KITS

PUERTA CORREDERA VIDRIO A PARED

KIT DE PORTE COULISSANTE FIXÉE AU MUR
KIT SLIDING DOOR FIXED TO THE WALL
KIT PORTA SCORREVOLE FISSATA A PARETE

5379/P28 con tubo 2 m

- 4350/228 1 u. tubo 2 m
- 4352/028 1 u. guía inf. "u"
- 236/0028 2 u. tapón final
- 5356/028 1 u. tope cojinete
- 5357/028 1 u. tope cojinete
- 5362/028 2 u. cojinete
- 4337/028 1 u. uñero
- 4353/028 4 u. fijación tubo-pared

○ € / u

5380/P28 con tubo 3 m

- 4350/328 1 u. tubo 3 m
- 4352/028 1 u. guía inf. "u"
- 236/028 2 u. tapón final
- 5356/028 1 u. tope cojinete
- 5357/028 1 u. tope cojinete
- 5362/028 2 u. cojinete
- 4337/028 1 u. uñero
- 4353/028 6 u. fijación tubo-pared

○ € / u

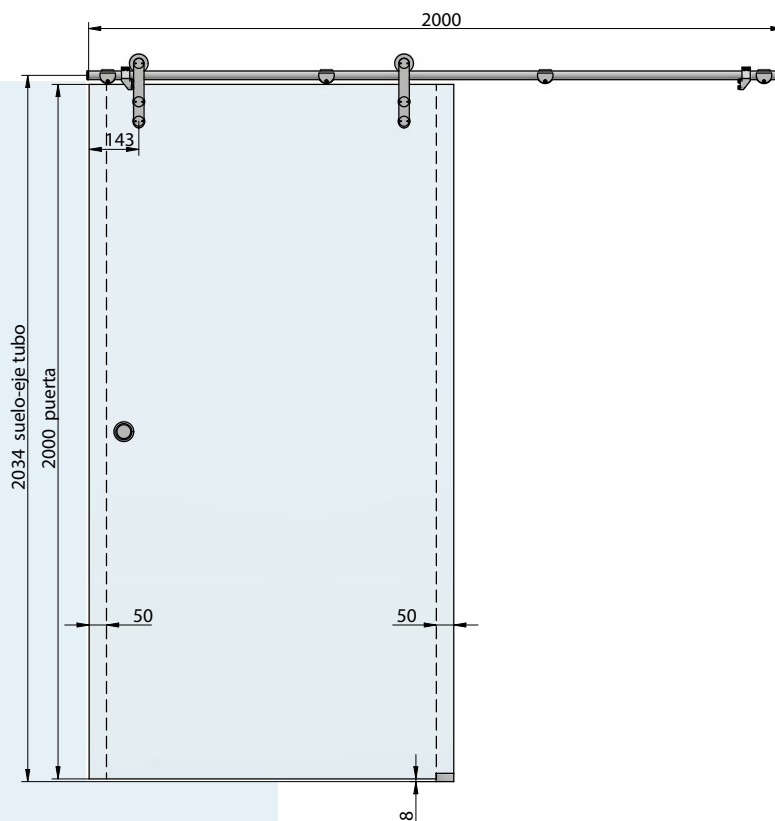

PUERTA CORREDERA VIDRIO + VIDRIO FIJO

KIT DE PORTE COULISSANTE FIXÉE AU MUR DE VERRE
KIT SLIDING DOOR FIXED TO THE GLASS-WALL
KIT PORTA SCORREVOLE FISSATA A PARETE DI VETRO

5369/P28 con tubo 2 m

- 4350/228 1 u. tubo 2 m
- 4352/028 1 u. guía inf. "u"
- 236/028 2 u. tapón final
- 5356/028 1 u. tope cojinete
- 5357/028 1 u. tope cojinete
- 5362/028 2 u. cojinete
- 4337/028 1 u. uñero
- 5354/028 4 u. fijación tubo-vidrio

○ € / u

5381/P28 con tubo 3 m

- 4350/328 1 u. tubo 3 m
- 4352/028 1 u. guía inf. "u"
- 236/028 2 u. tapón final
- 5356/028 1 u. tope cojinete
- 5357/028 1 u. tope cojinete
- 5362/028 2 u. cojinete
- 4337/028 1 u. uñero
- 5354/028 6 u. fijación tubo-vidrio

○ € / u

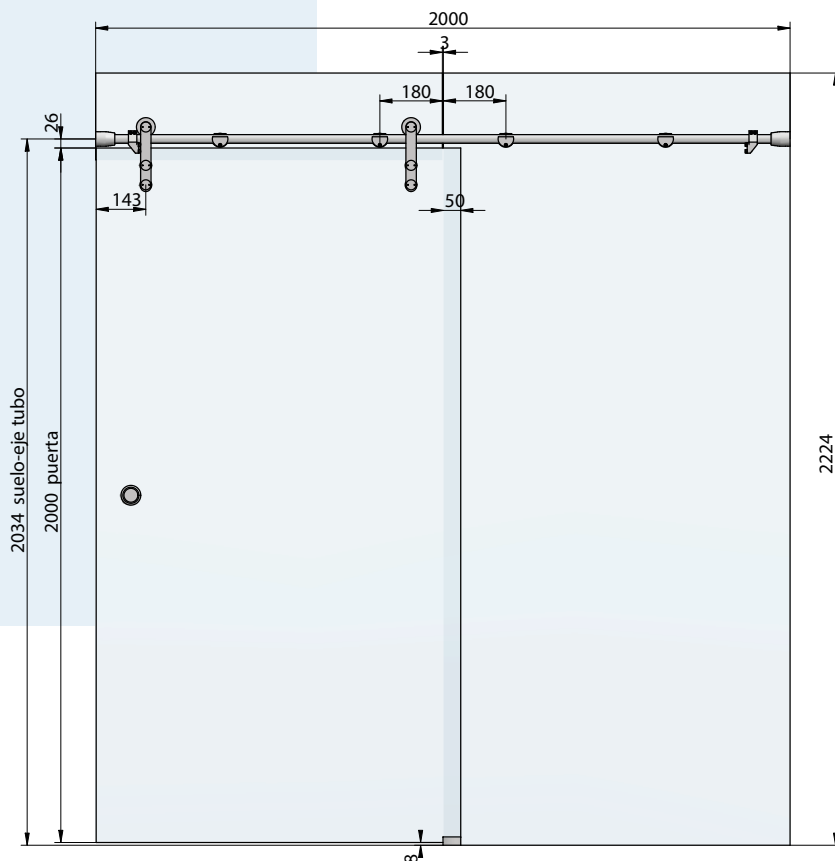

*CORREDERA TOKYO

PUERTA CORREDERA CON RELLAMADA AUTOMÁTICA

- Funciona como un cierrapuerta de suelo
- Peso max: 100 kg/puerta
- Vidrio 8-12 mm
- Largo max. 2 M
- Aluminio anodizado plata

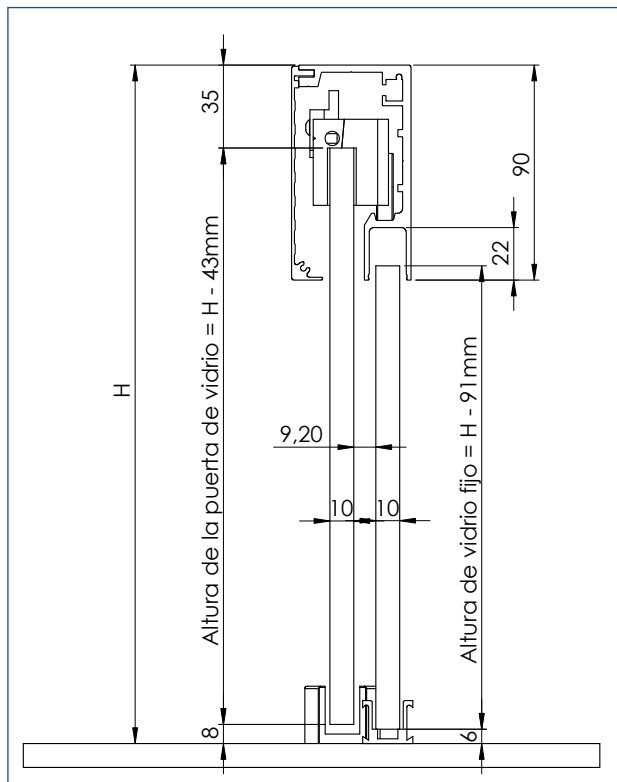

CARRIL TECHO + TAPA
COULISSE HAUTE + COUVERTURE
UPPER TRACK + COVER PROFILE
GUIDA SUPERIORE + COPERTINA
*5911/201 2 m



PERFIL INFERIOR VIDRIO FIJO
PROFIL INFERIEUR VERRE FIXE
BOTTOM PROFILE FIXED GLASS
PROFILO INFERIORE VETRO FISSO
con 5911
*5912/101 1 m



PINZA PORTAVIDRIO
PINCE POUR VERRE
CLAMP FOR GLASS
PINZA PER VETRO
*5920/001



AMORTIGUADORES
AMORTISSEURS
DUMPERS - SELFLOSING
AMORTIZZATORE
*5921/001



STOP CARRIL SUPERIOR
STOP COULISSE HAUTE
UPPER TRACK STOP
STOP GUIDA SUPERIORE
*5926/001 der.
*5927/001 izq.



se vende en kit
MUELLE RELAMADA PUERTA
AMORTISSEURS
RECALLING
MOLLA RICHIAMO PORTA
*5922/001



GUÍA SUELO
GUIDAGE AU SOL
FLOOR GUIDE
GUIDA A PAVIMENTO
4352/028



STOP SUELO
STOP AU SOL
FLOOR STOP
STOP A PAVIMENTO
*5924/001



REMATE FINAL CARRIL - GRIS
BOUCHON COULISSE - GRIS
END-CAP TRACK - GRAY
COPRITESTA TUBO - GRIGIO.
*5925/009 kit der/izq



UÑERO DOBLE ADHESIVO
POIGNÉE DOUBLE ADHESIVE
DOUBLE ADHESIVE PULL
POMO DOPPIO ADHESIVO
4207/0..
4207/0..



POMO
POIGNÉE
KNOB
POMO
4223/0..



GALGA MONTAJE UÑEROS
GABARIT DE MONTAGE
INSTALLATION TOOL
SAGOMA AIUTO MONTAGGIO
4209/000

CR. BRILLO	PL. MATE	INOX BR	INOX SAT
CHR. POLI	ANOD. M	INOX POLI	INOX SAT
BR. CHR	AV. CHR	P. S. S.	S. S. S.
CR. LUC.	AV. OPAC	INOX LUC	INOX SAT
32	01	22	28

Al	2 m	8-12 mm	€/u
			*o
Al	1 m	8-12 mm	€/u
			*o
Al Zn	100kg/2u.	8-12 mm	€/u
			*o
Al	plas		€/u
			*o
Al	plas		€/u
			*o
			€/u
			*o
Al	plas		€/u
			o
Al	plas		€/u
			*o
Al	∞ 5910		€/u
			*o
∅ 60			€/u
Al			o
inox s.s.			o
Al	100		€/u
			o
			o
Al			€/u
			o

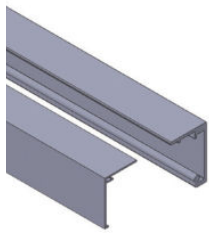

CARRIL + TAPA CARRIL
COULISSE HAUTE +
COUVERTURE COULISSE
UPPER TRACK +
COVER PROFIL
GUIDA SUPERIORE +
COPERTINA GUIDA
*5130/201 2 m
*5130/301 3 m

NEGRO NOIR BLACK NERO	PL.M ALU.M ALL.NAT	INOX BR INOX POLI P.S.S. INOX LUC	INOX SAT INOX SAT S.S.S. INOX SAT
0N	01	22	28

Al	2 - 3m	43x61	€/u
	8 - 10 mm		



KIT PINZA PORTAVIDRIO CON
AMORTIGUADORES, GUIADOR
DE SUELO Y TAPAS FINALES
PINCE À VERRREVEC
AMORTISSEURS, GUIDE
CAPUCHONS DE SOL ET
D'EXTRÉMITÉ
GLASS CLAMP WITH
SHOCK ABSORBERS, GUIDE
FLOOR AND END CAPS
MORSETTO DI VETRO CON
AMMORTIZZATORI, GUIDA
TAPPI DI FONDO E DI FONDO
*5133/001

Al	60kg/2u.	282x33	€/u
	8 - 10 mm		



UÑERO DOBLE ADHESIVO
POIGNÉE DOUBLE ADHESIVE
DOUBLE ADHESIVE PULL
POMO DOPPIO ADHESIVO
4207/0..
4207/0..

Al		€/u
inox		
s.s.		



GALGA MONTAJE UÑEROS
GABARIT DE MONTAGE
INSTALLATION TOOL
SAGOMA AIUTO MONTAGGIO
4209/000

Al	∅ 60	€/u
----	------	-----



POMO
POIGNÉE
KNOB
POMO
4223/0..

Al	100	€/u
	8-10 mm	

CP. BRILLO CHR. POLI BR. CHR CR. LUC.	32	€/u
--	----	-----

KITS

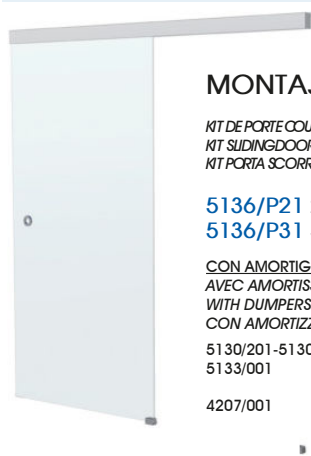

MONTAJE A PARED

KIT DE PORTE COULISSANTE FIXÉE AU MUR
KIT SLIDING DOOR FIXED TO THE WALL
KIT PORTA SCORREVOLE FISSATA A PARETE

5136/P21 2 m
5136/P31 3 m

CON AMORTIGUADOR,
AVEC AMORTISSEURS,
WITH DUMPERS,
CON AMORTIZZATORI

5130/201-5130/301 1 u. carril + 1 u. tapa carril
5133/001 1 u. kit pinzas+buffer+ tapas finales+guiador suelo
4207/001 1 u. uñero

PL.M ALU.M ALL.NAT	01
--------------------------	----

€/u

*CORREDERA SHANGHAI

- peso max puerta: 60 kg
- vidrio puerta: 8-10 mm
- sin muesca en el vidrio
- poids limite porte: 60 kg/porte
- verre 8-10mm
- sans encoches
- weight max door: 60 kg/door
- glass 8-10mm
- without cut -out
- peso max po rta: 60 kg
- vetro 8-10mm
- senza tacca nel vetro

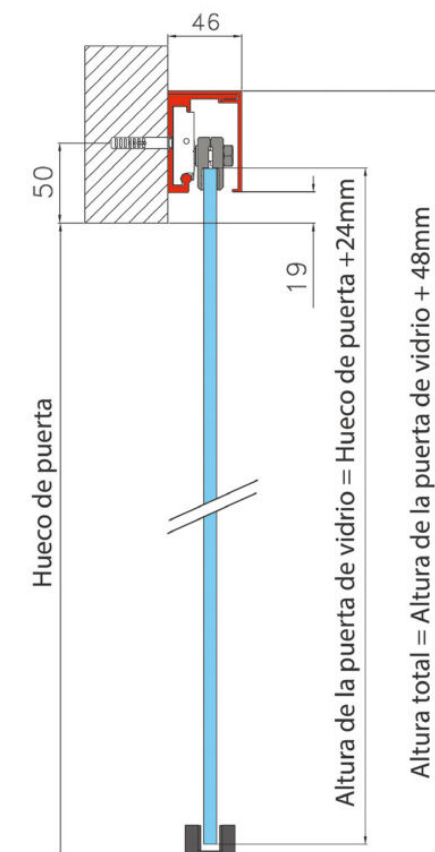

*CORREDERA PISA



PINZAS OCULTAS

- peso max. puerta: 100 kg/puerta
- vidrio 8-10 mm
- con o sin muesca en el vidrio

- pods-limite porte: 100 kg/porte
- verre 8-10 mm
- encoches - sans encoches
- weight max. door: 100 kg/door
- glass 8-10 mm
- cut-out - without cut-out
- peso max. porta: 100 kg/porta
- vetro 8-10 mm
- tacca - senza tacca nel vetro

- Modelo PISA con tapa frontal ref. 3471/101, tapas laterales ref. 3474/001 y kit pinzas 3478/001. Peso máximo de 100 kg/puerta. Para vidrio laminado o templado de 8-10 mm.
- Modèle PISA avec couvercle avant réf. 3471/101, couvercles latéraux réf. 3474/001 et kit d'étrier 3478/001. Poids maximum de 100 kg / porte. Pour le verre feuilleté ou trempé de 8-10 mm.
- PISA model with front cover ref. 3471/101, side covers ref. 3474/001 and caliper kit 3478/001. Maximum weight of 100 kg / door. For laminated or tempered glass of 8-10 mm.
- Modello PISA con coperchio anteriore rif. 3471/101, coperture laterali rif. 3474/001 e kit pinza 3478/001. Peso massimo di 100 kg / porta. Per vetro stratificato o temperato di 8-10 mm.

KIT PINZAS DE 100KG CON BUFFER Y 2 PINZAS
3478/001

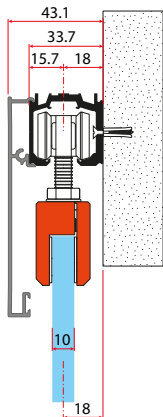
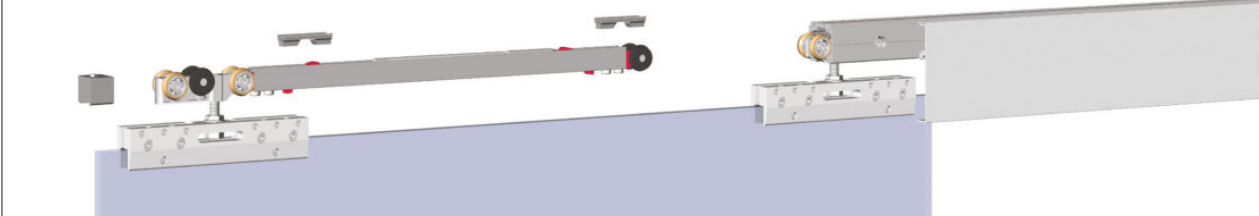

- Fijación a pared con tapa lateral.
- Fixation au mur avec couverture latéral.
- Fixing to the wall with side cover.
- Fissaggio al muro con copertura laterale.

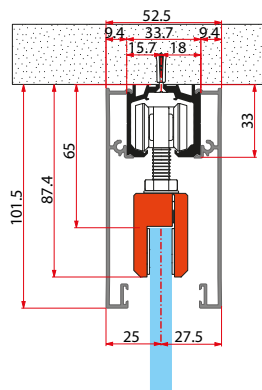

- Fijación a techo con tapas laterales.
- Fixation au plafond avec des couvertures latéraux.
- Fixation to ceiling with side covers.
- Fissaggio a soffitto con copertura laterali.

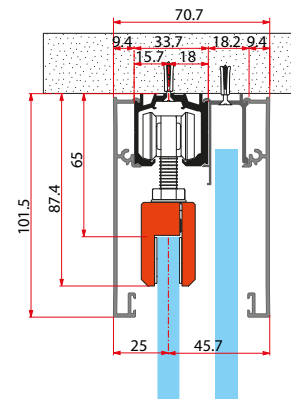

- Fijación a techo con tapas laterales y cristal fijo.
- Fixation au plafond avec des couverture latéraux et verre fixe.
- Fixing to the ceiling with side covers and fixed glass.
- Fissaggio al soffitto con copertura laterali e vetro fisso.



PINZAS A LA VISTA CON TAPAS EMBELLECEDORAS

- peso max. puerta: 100 kg/puerta
- vidrio 8-10 mm
- con muesca en el vidrio
- pods-limite porte: 100 kg/porte
- verre 8-10 mm
- encoches
- weight max. door: 100 kg/door
- glass 8-10 mm
- cut-out
- peso max. porta: 100 kg/porta
- vetro 8-10 mm
- tacca nel vetro
- Modelo PISA con tapa frontal ref. 3472/101, tapas laterales ref. 3473/001 y kit pinzas 3476/001. Peso máximo de 100 kg/puerta. Para vidrio templado de 8-10 mm.
- Modèle PISA avec couvercle avant réf. 3472/101, couvercles latéraux réf. 3473/001 et kit d'étrier 3476/001. Poids maximum de 100 kg / porte. Pour verre trempé de 8-10 mm.
- PISA model with front cover ref. 3472/101, side covers ref. 3473/001 and caliper kit 3476/001. Maximum weight of 100 kg / door. For tempered glass of 8-10 mm.
- Modello PISA con coperchio anteriore réf. 3472/101, coperture laterali réf. 3473/001 e kit pinza 3476/001. Peso massimo di 100 kg / porta. Per vetri temperati di 8-10 mm.

KIT PINZAS DE 100KG CON BUFFER Y 2 PINZAS 3476/028

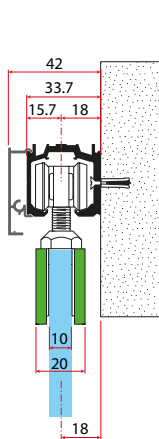
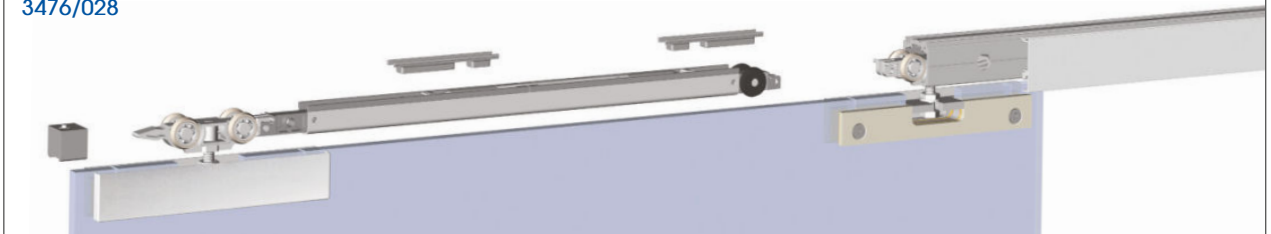

- Fijación a pared con tapa lateral.
- Fixation au mur avec couvercle latéral.
- Fixing to the wall with side cover.
- Fissaggio al muro con copertura laterale.

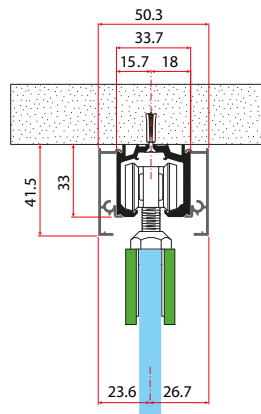

- Fijación a techo con tapas laterales.
- Fixation au plafond avec des couvertures latérales.
- Fixation to ceiling with side covers.
- Fissaggio a soffitto con coperture laterali.

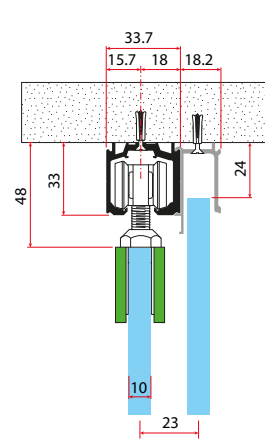

- Fijación a techo con cristal fijo.
- Fixation au plafond avec verre fixe.
- Fixing to the ceiling with fixed glass.
- Fissaggio al soffitto con vetro fisso.

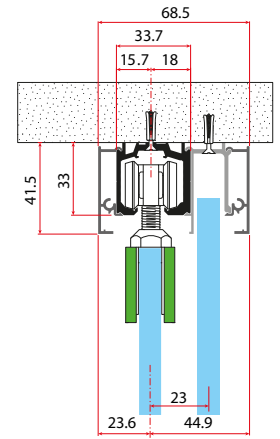

- Fijación a techo con tapas laterales y cristal fijo.
- Fixation au plafond avec des couvertures latérales du verre fixe.
- Fixing to the ceiling with side covers and fixed glass.
- Fissaggio al soffitto con coperture laterali e vetro fisso.

*CORREDERA PISA

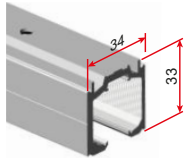

CARRIL SUPERIOR
RAIL EN ALUMINIUM
ALUMINIUM RAIL
BINARIO IN ALUMINIO
*3470/101
FACTURACIÓN EN 2M., 3M. Y 4M.

ALU. M
ALU. M
ALU. M
ALL. NAT
01

Al 6 m €/m

*O

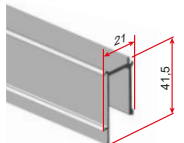

PERFIL PARA VIDRIO FIJO
PROFIL POUR VERRE FIXE
PROFILE FOR FIXED GLASS
PROFLO PER VETRO FISSO
*3475/101
FACTURACIÓN EN 2M., 3M. Y 4M.

Al ∞ 3470
6 m €/m

*O

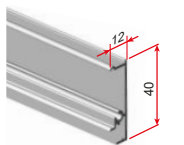

TAPA DE CARRIL SUPERIOR
COUVERTURE DE RAIL SUPÉRIEURE
TOP RAIL COVER
COPERTURA SUPERIORE DEL BINARIO
*3472/101
FACTURACIÓN EN 2M., 3M. Y 4M.

Al ∞ 3476
6 m €/m

*O

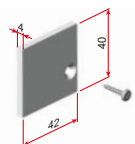

TAPA LATERAL DE CARRIL SUPERIOR
COUVERTURE LATÉRALE DU RAIL SUPÉRIEUR
TOP RAIL SIDE COVER
COPERTURA LATERALE SUPERIORE
*3473/001 Set dcha. izda.

Al ∞ 3472 €/u

*O

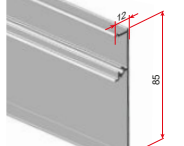

TAPA DE CARRIL SUPERIOR
COUVERTURE DE RAIL SUPÉRIEURE
TOP RAIL COVER
COPERTURA SUPERIORE DEL BINARIO
*3471/101
FACTURACIÓN EN 2M., 3M. Y 4M.

Al ∞ 3478
6 m €/m

*O

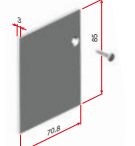

TAPA LATERAL DE CARRIL SUPERIOR
COUVERTURE LATÉRALE DU RAIL SUPÉRIEUR
TOP RAIL SIDE COVER
COPERTURA LATERALE SUPERIORE
*3474/001 Set dcha. izda.

Al ∞ 3471 €/u

*O



KIT COJINETES Y 2 PINZAS PARA CRISTAL.
KIT CHARIOT ET 2 PINCE POUR VERRE.
KIT TOP ROLLERS AND 2 CLAMPS FOR GLASS.
KIT SCORREVOLI E 2 PINZE PER VETRO
*3478/001

Al ∞ 3474
∞ 3471
8-10mm
100kg/u €/u

*O

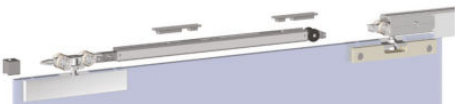

KIT COJINETES Y 2 PINZAS PARA CRISTAL.
KIT CHARIOT ET 2 PINCE POUR VERRE.
KIT TOP ROLLERS AND 2 CLAMPS FOR GLASS.
KIT SCORREVOLI E 2 PINZE PER VETRO
*3476/028

INOX SAT
INOX SAT
S.S.S.
INOX SAT
28

8-10mm 100kg/u

inox s.s. ∞ 3472
∞ 3473
∞ 3477

*O

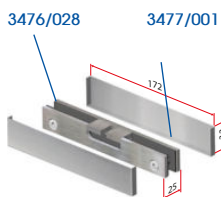

KIT DE 2 TAPAS PARA PINZAS.
LOT DE 2 COUVERCLES POUR PINCES.
SET OF 2 CAPS FOR CLAMP
KIT 2 VELLETTA PINZA.
*3477/001
Solo para KIT 3476

ALU. M
ALU. M
ALU. M
ALL. NAT
01
inox s.s. ∞ 3476

*O

KITS

MONTAJE A PARED

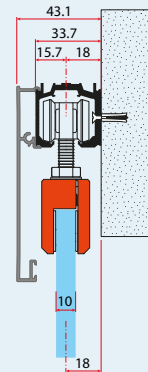
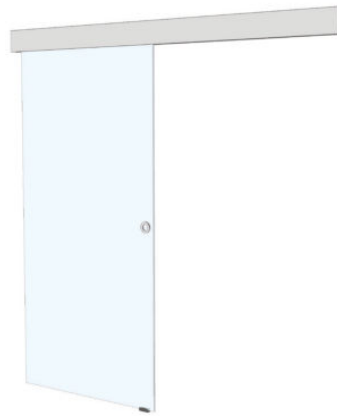

3490/P21 2 m
3490/P31 3 m

ALU. M
ALU. M
ALU. M
ALL. NAT
01

€/u

KIT PUERTA CORREDERA A PARED.
KIT DE PORTE COULISSANTE FIXÉE AU MUR
KIT SLIDING DOOR FIXED TO THE WALL
KIT PORTA SCORREVOLE FISSATA A PARETE
3470/101 2/3 m. Carril.
3471/101 2/3 m. Tapa carril grande
3474/001 1 u. Set de tapas laterales
4207/001 1 u. Uñero adhesivo
3478/001 1 u. Kit pinzas para cristal LAMINADO/TEMPLADO
Incluye guíador para el suelo.

MONTAJE A PARED

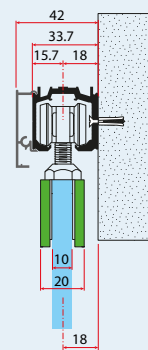
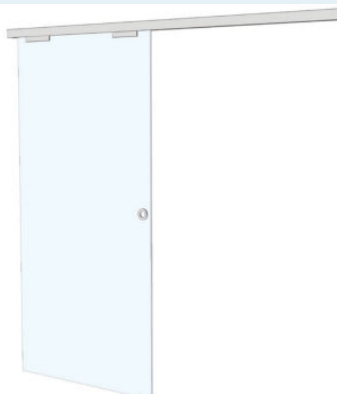

3491/P21 2 m
3491/P31 3 m

€/u

KIT PUERTA CORREDERA A PARED.
KIT DE PORTE COULISSANTE FIXÉE AU MUR
KIT SLIDING DOOR FIXED TO THE WALL
KIT PORTA SCORREVOLE FISSATA A PARETE
3470/101 2/3 m. Carril.
3472/101 2/3 m. Tapa carril pequeña.
3473/001 1 u. Set de tapas laterales.
4207/001 1 u. Uñero adhesivo.
3476/028 1 u. Kit pinzas INOX para cristal TEMPLADO.
Incluye guíador para el suelo.
NO Incluye:
3477/001

KITS

ALU, M
ALU, M
ALU, M
ALL, NAT
01

MONTAJE A TECHO

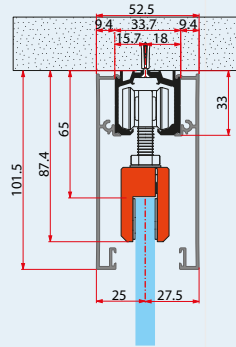
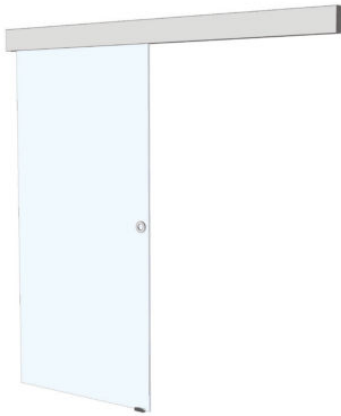

3492/T21 2 m
3492/T31 3 m



KIT PUERTA CORREDERA A TECHO
KIT DE PORTE COULISSANTE FIXÉE AU TOIT
KIT SLIDING DOOR FIXED TO THE CEILING
KIT PORTA SCORREVOLE FISSATA A TETTO
3470/101 2/3 m. Carril.
3471/101 4/6 m. Tapa carril grande.
3474/001 1 u. Set tapas laterales.
4207/001 1 u. Uñero adhesivo.
3478/001 1 u. Kit pinzas para cristal LAMINADO / TEMPLADO.
Incluye guiador para el suelo.

€/u

KITS

ALU, M
ALU, M
ALU, M
ALL, NAT
01

MONTAJE A TECHO + VIDRIO FIJO

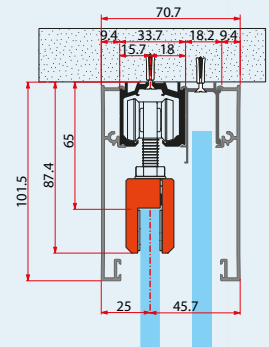
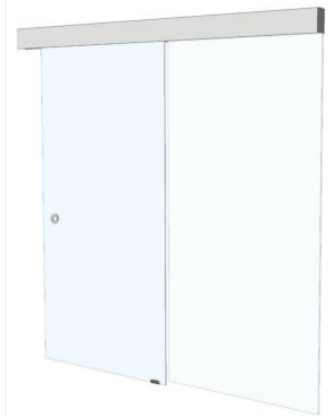

3494/T21 2 m
3494/T31 3 m



KIT PUERTA CORREDERA A TECHO CON VIDRIO FIJO
KIT PORTE COULISSANTE AVEC VITRE FIXE
ROOF SLIDING DOOR KIT WITH FIXED GLASS
KIT PORTA SCORREVOLE SUL TETTO CON VETRO FISSO
3470/101 2/3 m. Carril.
3471/101 4/6 m. Tapa carril grande.
3474/001 1 u. Set de tapas laterales.
3475/101 2/3 m. Carril para vidrio fijo.
4207/001 1 u. Uñero adhesivo.
3478/001 1 u. Kit pinzas para cristal LAMINADO / TEMPLADO.
Incluye guiador para el suelo.

€/u

MONTAJE A TECHO

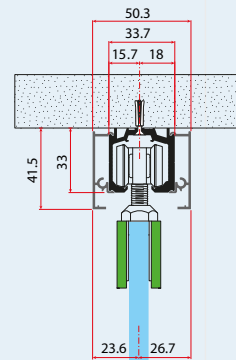
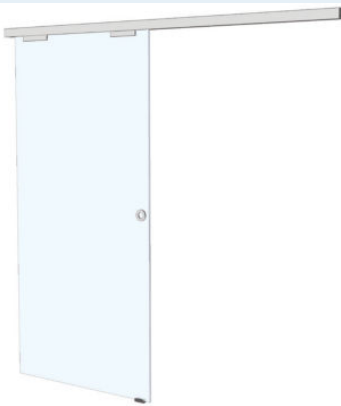

3493/T21 2 m
3493/T31 3 m



KIT PUERTA CORREDERA A TECHO
KIT DE PORTE COULISSANTE FIXÉE AU TOIT
KIT SLIDING DOOR FIXED TO THE CEILING
KIT PORTA SCORREVOLE FISSATA A TETTO
3470/101 2/3 m. Carril.
3472/101 4/6 m. Tapa carril pequeña.
3473/001 1 u. Set de tapas laterales.
4207/001 1 u. Uñero adhesivo.
3476/028 1 u. Kit pinzas INOX para cristal TEMPLADO.
Incluye guiador para el suelo.
NO Incluye:
3477/001

€/u

MONTAJE A TECHO + VIDRIO FIJO

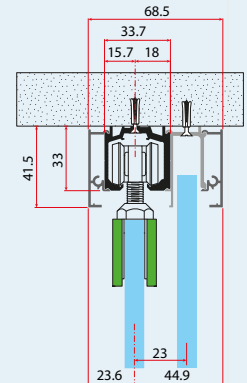

3495/T21 2 m
3495/T31 3 m



KIT PUERTA CORREDERA A TECHO CON VIDRIO FIJO
KIT PORTE COULISSANTE AVEC VITRE FIXE
ROOF SLIDING DOOR KIT WITH FIXED GLASS
KIT PORTA SCORREVOLE SUL TETTO CON VETRO FISSO
3470/101 2/3 m. Carril.
3472/101 4/6 m. Tapa carril pequeña.
3473/001 1 u. Set de tapas laterales.
3475/101 2/3 m. Carril para vidrio fijo.
4207/001 1 u. Uñero adhesivo.
3476/028 1 u. Kit pinzas INOX para cristal TEMPLADO.
Incluye guiador para el suelo.
NO Incluye:
3477/001

€/u

*CORREDERA MONZA



PINZAS OCULTAS

- peso max. puerta: 100 kg/puerta
- vidrio 8-10 mm
- con o sin muesca en el vidrio
- pods-limite porte: 100 kg/porte
- verre 8-10 mm
- encoches - sans encoches
- weight max. door: 100 kg/door
- glass 8-10 mm
- cut-out - without cut-out
- peso max. porta: 100 kg/porta
- vetro 8-10 mm
- tacca - senza tacca nel vetro
- Modelo MONZA con tapa frontal ref. 3481/101 y kit pinzas 3478/001. Peso máximo de 100 kg/puerta. Para vidrio laminado o templado de 8-10 mm.
- Modèle MONZA avec couvercle avant réf. 3481/101 et kit d'étrier 3478/001. Poids maximum de 100 kg / porte. Pour le verre feuilleté ou trempé de 8-10 mm.
- MONZA model with front cover ref. 3481/101 and caliper kit 3478/001. Maximum weight of 100 kg / door. For laminated or tempered glass of 8-10 mm.
- Modello MONZA con coperchio anteriore rif. 3481/101 e kit pinza 3478/001. Peso massimo di 100 kg / porta. Per vetro stratificato o temperato di 8-10 mm.

KIT PINZAS DE 100KG CON BUFFER Y 2 PINZAS
3478/001

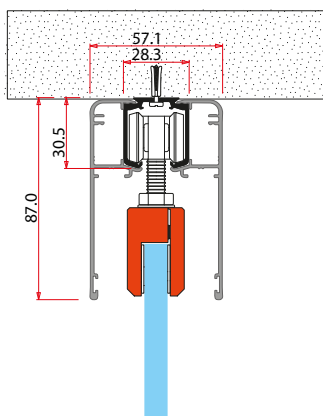
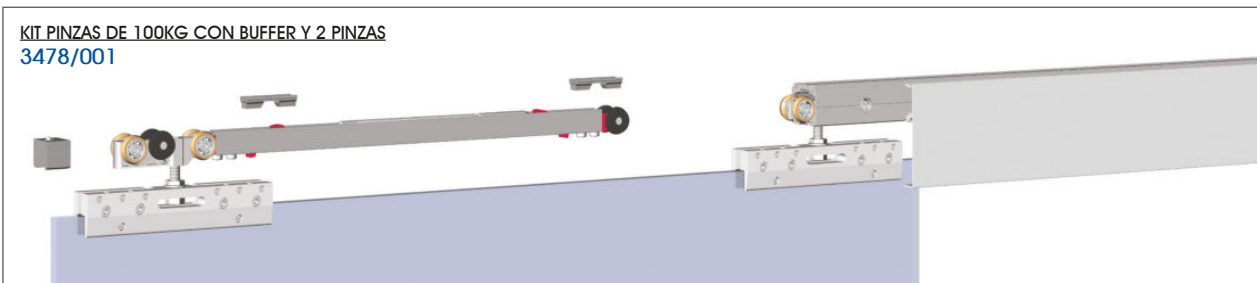

- Fijación a techo con tapas laterales.
- Fixation au plafond avec des couvertures latérales.
- Fixation to ceiling with side covers.
- Fissaggio a soffitto con coperture laterali

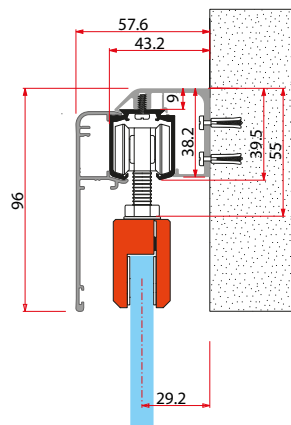

- Fijación a pared con tapa lateral.
- Fixation au mur avec couvertures latéral.
- Fixing to the wall with side cover.
- Fissaggio al muro con coperchio laterale.

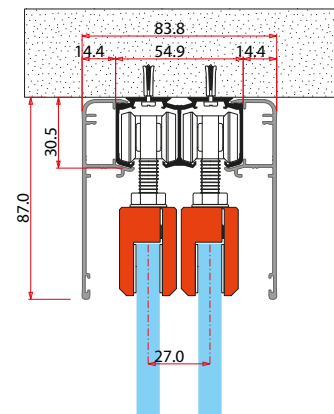

- **CONSULTAR PRECIO Y PLAZO DE ENTREGA.**
Fijación a techo con tapas laterales.
- **VÉRIFIEZ LE PRIX ET LE DÉLAI DE LIVRAISON.**
Fixation au plafond avec des couvertures latérales.
- **CHECK PRICE and DELIVERY PERIOD.**
Fixation to ceiling with side covers.
- **CONSULTARE PREZZO e TEMPI DI CONSEGNA.**
Fissaggio a soffitto con coperture laterali.



PINZAS A LA VISTA CON TAPAS EMBELLECEDIRAS

- peso max. puerta: 100 kg/puerta
- vidrio 8-10 mm
- con muesca en el vidrio
- pods-limite porte: 100 kg/porte
- verre 8-10 mm
- encoches
- weight max. door: 100 kg/door
- glass 8-10 mm
- cut-out
- peso max. porta: 100 kg/porta
- vetro 8-10 mm
- tacca nel vetro
- Modelo MONZA con carril empotrado y kit pinzas 3476/001. Peso máximo de 100 kg/puerta. Para vidrio templado de 8-10 mm.
- Modèle MONZA avec rail encastré et kit de clips 3476/001. Poids maximum de 100 kg / porte. Pour verre trempé de 8-10 mm.
- MONZA model with recessed rail and clip kit 3476/001. Maximum weight of 100 kg / door. For tempered glass of 8-10 mm.
- Modello MONZA con binario incassato e kit clip 3476/001. Peso massimo di 100 kg / porta. Per vetri temperati di 8-10 mm.

KIT PINZAS DE 100KG CON BUFFER Y 2 PINZAS
3476/028

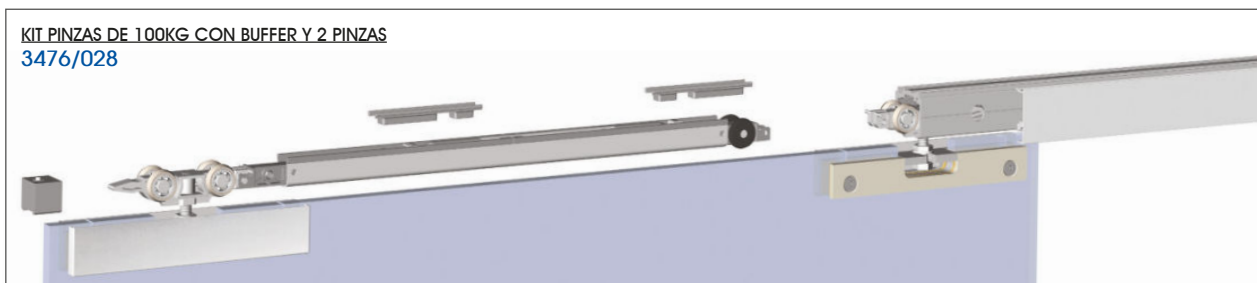

**PARA EMPOTRAR EL PERFIL AL TECHO
UTILIZAR LOS PERFILES:
5450 (CARRIL SENCILLO) Y 5451 (DOBLE CARRIL)**

***CORREDERA MONZA**

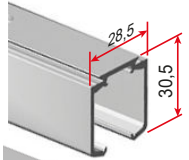

CARRIL SUPERIOR
RAIL EN ALUMINIUM
ALUMINIUM RAIL
BINARIO IN ALUMINIO
***3480/101**
FACTURACIÓN EN 2M., 3M Y 4M.

ALU. M	ALU. M	ALU. M	ALL. NAT
Al	6 m	€/m	
			*o

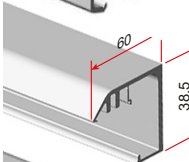

PERFIL DE ANCLAJE A PARED
PROFIL D'ANCRAGE MURAL
WALL ANCHOR PROFILE
PROFILE PER FISSAGGIO A PARETE
***3482/101**
FACTURACIÓN EN 2M., 3M Y 4M.

Al	∞ 3480		
6 m	€/m		
			*o

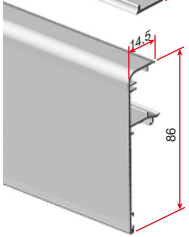

TAPA DE CARRIL SUPERIOR
COUVERTURE DE RAIL SUPÉRIEURE
TOP RAIL COVER
COPERTURA SUPERIORE DEL BINARIO
***3481/101**
FACTURACIÓN EN 2M., 3M Y 4M.

Al	∞ 3478		
6 m	€/m		
			*o



TORNILLOS ESPECIALES AUTOROSCANTES
VIS DE FIXATION
FIXING SCREW
VITE DI FISSAGGIO
***3483/001**

inox s.s.	∞ 3482	€/u	
			*o

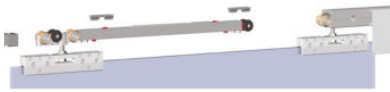

KIT COJINETES Y 2 PINZAS PARA CRISTAL
KIT CHARIOT ET 2 PINCE POUR VERRE
KIT TOP ROLLERS AND 2 CLAMPS FOR GLASS
KIT SCORREVOLI E 2 PINZE PER VETRO
***3478/001**

Al	8-10mm		
100kg/u	€/u		
			*o

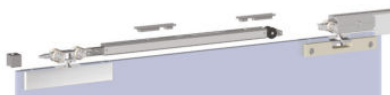

KIT COJINETES Y 2 PINZAS PARA CRISTAL
KIT CHARIOT ET 2 PINCE POUR VERRE
KIT TOP ROLLERS AND 2 C CLAMPS FOR GLASS
KIT SCORREVOLI E 2 PINZE PER VETRO
***3476/028**

inox s.s.	8-10mm		
100kg/u	€/u		
∞ 3477			*o

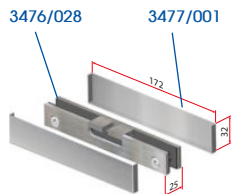

KIT DE 2 TAPAS PARA PINZAS
LOT DE 2 COUVERCLES POUR PINCES
SET OF 2 CAPS FOR CLAMP
KIT 2 VELLETTA PINZA
***3477/001**
Solo para KIT 3476

ALU. M	ALU. M	ALU. M	ALL. NAT
Al	€ / u		
∞ 3476			*o

ACCESORIOS



UNERO DOBLE ADHESIVO
POIGNEE DOUBLE ADHESIVE
DOUBLE ADHESIVE PULL
POMO DOPPIO ADHESIVO
4207/0..



GALGA MONTAJE UNEROS
GABARIT DE MONTAGE
INSTALLATION TOOL
SAGOMA AIUTO MONTAGGIO
4209/000



UNERO POIGNEE
KNOB
POMO
4337/028

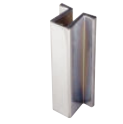

POMO POIGNEE
KNOB
POMO
4223/0..



UNERO POIGNEE
KNOB
POMO
4322/028

PL. M ALU. M ALU. M ALL. NAT	INOX BR INOX POL P. S.S. INOX LUC	INOX SAT INOX SAT S. S.S. INOX SAT	NEGRO NOR. BLACK NERO
01	22	28	0N
			Al ∅6 m €/u
o	o	o	o
			Al €/u
inox s.s.	8-12 mm	∅ 46 mm	€/u
o			o
			Al 100 8-10 mm €/u
o	o		
inox s.s.	∅ 50 mm	8-12 mm	€/u
			o

KITS

ALU. M
ALU. M
ALU. M
ALL. NAT
01

MONTAJE A PARED

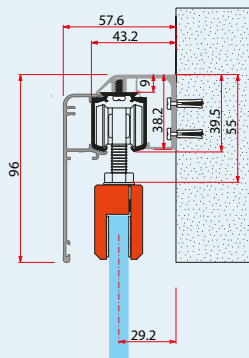
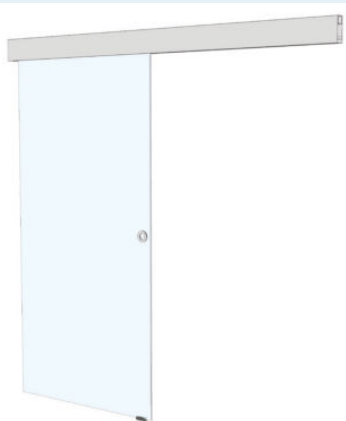

3500/P21 2 m
3500/P31 3 m

KIT PUERTA CORREDERA A PARED
KIT DE PORTE COULISSANTE FIXÉE AU MUR
KIT SLIDING DOOR FIXED TO THE WALL
KIT PORTA SCORREVOLE FISSATA A PARETE
3480/101 2/3 m. Carril.
3481/101 2/3 m. Tapa carril grande.
3482/101 2/3 m. Perfil para pared.
3483/001 6/8 u. Tornillo especial para fijación.
4207/001 1 u. Uñero adhesivo.
3478/001 1 u. Kit pinzas para cristal LAMINADO y TEMPLADO.
Incluye guiador para el suelo.

€/U

KITS

ALU. M
ALU. M
ALU. M
ALL. NAT
01

MONTAJE TIPO FRENTE DE ARMARIO

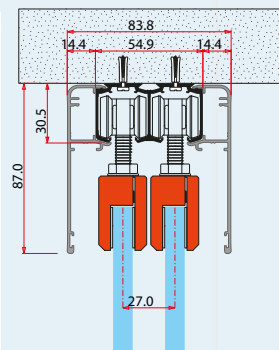
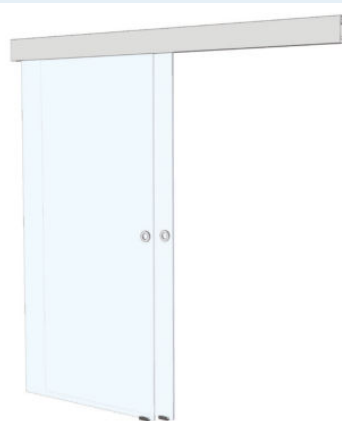

3502/T21 2 m
3502/T31 3 m

KIT PUERTA CORREDERA A TECHO
KIT DE PORTE COULISSANTE FIXÉE AU TOIT
KIT SLIDING DOOR FIXED TO THE CEILING
KIT PORTA SCORREVOLE FISSATA A TETTO
3480/101 4/6 m. Carril.
3481/101 4/6 m. Tapa carril grande.
4207/001 2 u. Uñero adhesivo.
3478/001 2 u. Kit pinzas para cristal LAMINADO y TEMPLADO.
Incluye guiador para el suelo.

€/U

MONTAJE A TECHO

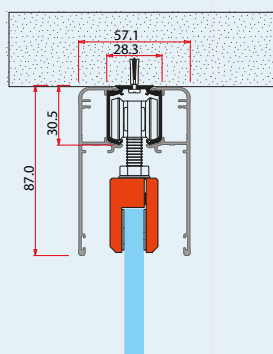
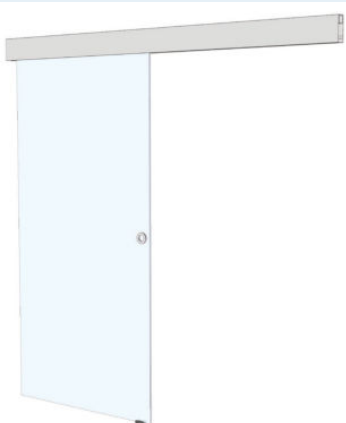

3501/T21 2 m
3501/T31 3 m

KIT PUERTA CORREDERA A TECHO
KIT DE PORTE COULISSANTE FIXÉE AU TOIT
KIT SLIDING DOOR FIXED TO THE CEILING
KIT PORTA SCORREVOLE FISSATA A TETTO
3480/101 2/3 m. Carril.
3481/101 4/6 m. Tapa carril grande.
4207/001 1 u. Uñero adhesivo.
3478/001 1 u. Kit pinzas para cristal LAMINADO y TEMPLADO.
Incluye guiador para el suelo.

€/U

*CORREDERA MONZA

KIT 3478/001
PARA PUERTA
CON BUFFER
- 100 Kg

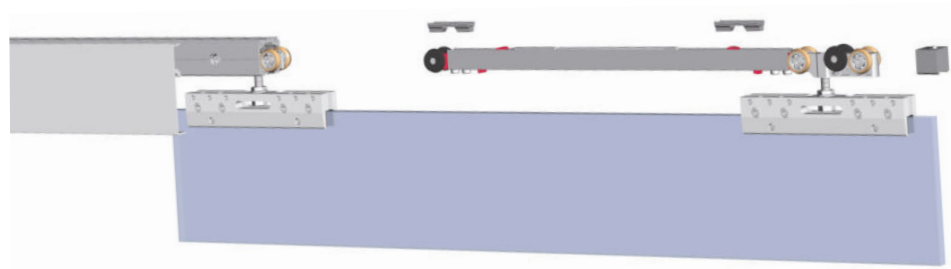

PINZAS OCULTAS

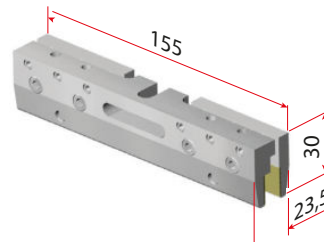
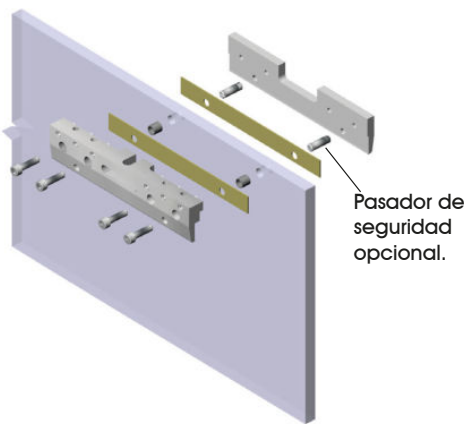

**NO ES NECESARIO HACER MUESCA EN VIDRIO LAMINADO
PASADOR DE SEGURIDAD SOLO EN VIDRIO TEMPLADO.**

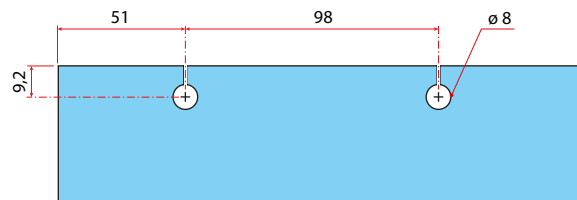

KIT 3476/028
PARA PUERTA
CON BUFFER
- 100 Kg

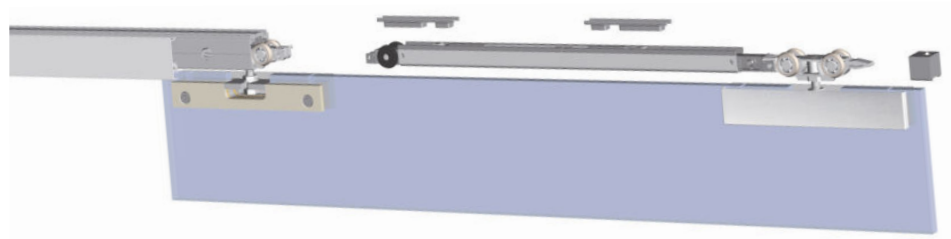

PINZAS A LA VISTA
CON TAPAS EMBELLECEDORAS

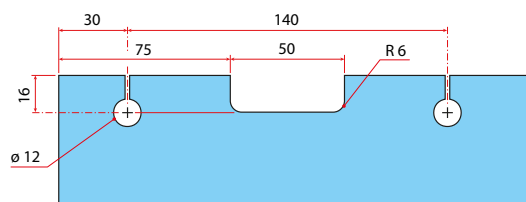
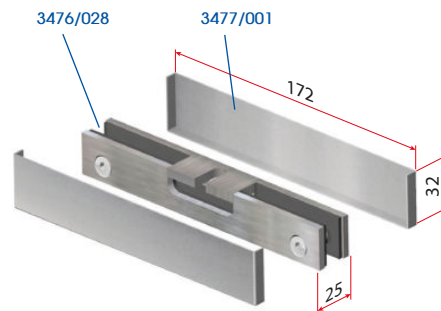
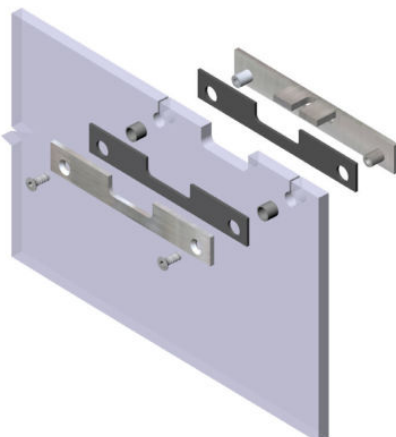

***CORREDERA RIMINI**



PUERTA CORREDERA CON GUÍA INVISIBLE

- peso max. puerta: 80 kg/puerta
- vidrio 8-10 mm
- con muesca en el vidrio

- pods-limite porte: 80 kg/porte
- verre 8-10 mm
- encoches
- weight max. door: 80 kg/door
- glass 8-10 mm
- cut-out
- peso max. porta: 80 kg/porta
- vetro 8-10 mm
- tacca nel vetro

- Corredera "INVISIBLE", solo necesita un anclaje a la pared que queda oculto detras del perfil.

- Apto para paredes de pladur.
- El vidrio descansa sobre los cojinetes inferiores.
- Peso max: 80 kg/puerta
- Vidrio templado: 8-10 mm
- Ancho MIN de cristal 625mm. Ancho MAX de cristal 1200mm.

- Porte coulissante "INVISIBLE", vous seulement besoin d'une ancrege au mur, qui se cache derrière le profil supérieur.
- Convient aux murs en plaques de plâtre.
- Le verre repose sur les roulement s inférieurs.
- Poids max: 80 kg/porte
- Verre trempé: 8-10 mm
- MIN largeur de verre 625mm. MAX largeur de verre 1200mm.

KIT RIMINI

KIT PUERTA INVISIBLE
KIT DE PORTE INVISIBLE
INVISIBLE DOOR KIT
KIT PORTA INVISIBLE
***3485/001**

ALU.M
ALU.M
ALL.NAT

01

Al 1.2m €/u

*o

- "INVISIBLE" door, you only need an anchor to the wall that is hidden behind the upper profile.

- Suitable for plasterboard walls.
- The glass rests on the lower bearings.
- Max weight: 80 kg/door
- Tempered glass: 8-10 mm
- MIN width of glass 625mm. MAX width of glass 1200mm.

- Scorrevole "INVISIBLE", serve solo un supporto al muro nascosto dietro il profilo superiore.

- Adatto per pareti in cartongesso.
- Il vetro riposa sui cuscinetti inferiori.
- Peso max: 80 kg/porta
- Vetro temperato: 8-10 mm
- Larghezza MIN del vetro 625mm. Larghezza MAX del vetro 1200mm.

Componentes del KIT - Composants du KIT - Components of the KIT - Componenti del KIT.

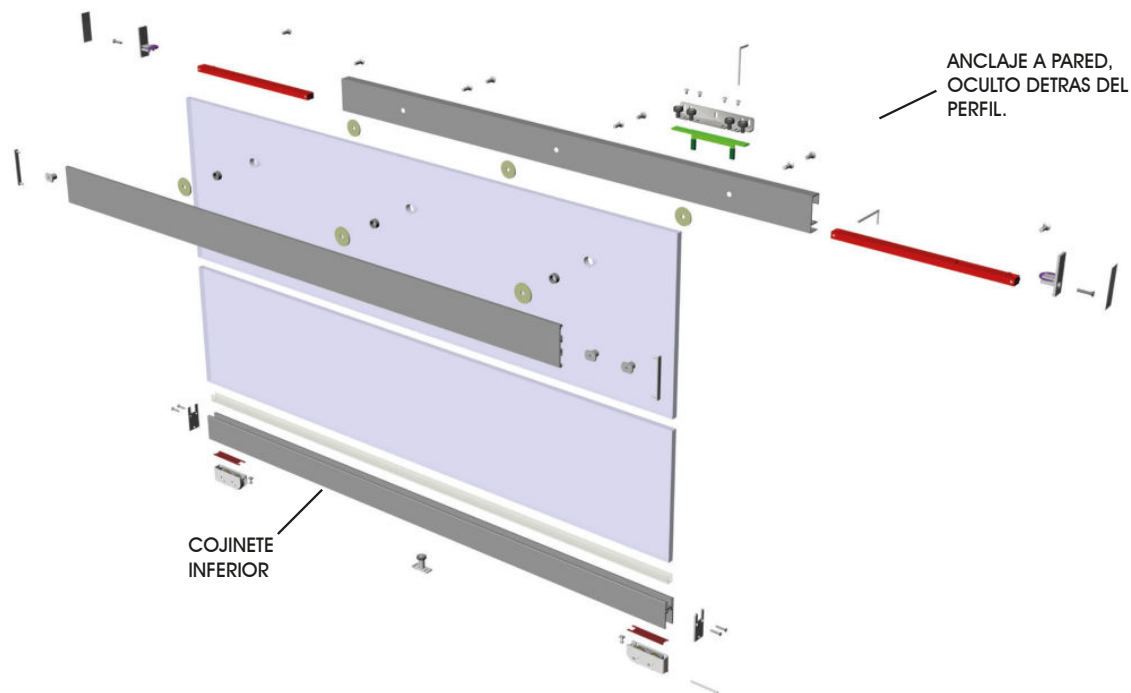

Cálculo de las dimensiones del cristal.

Calcul des dimensions du verre.

Calculation of the dimensions of glass.

Calcolo delle dimensioni del vetro

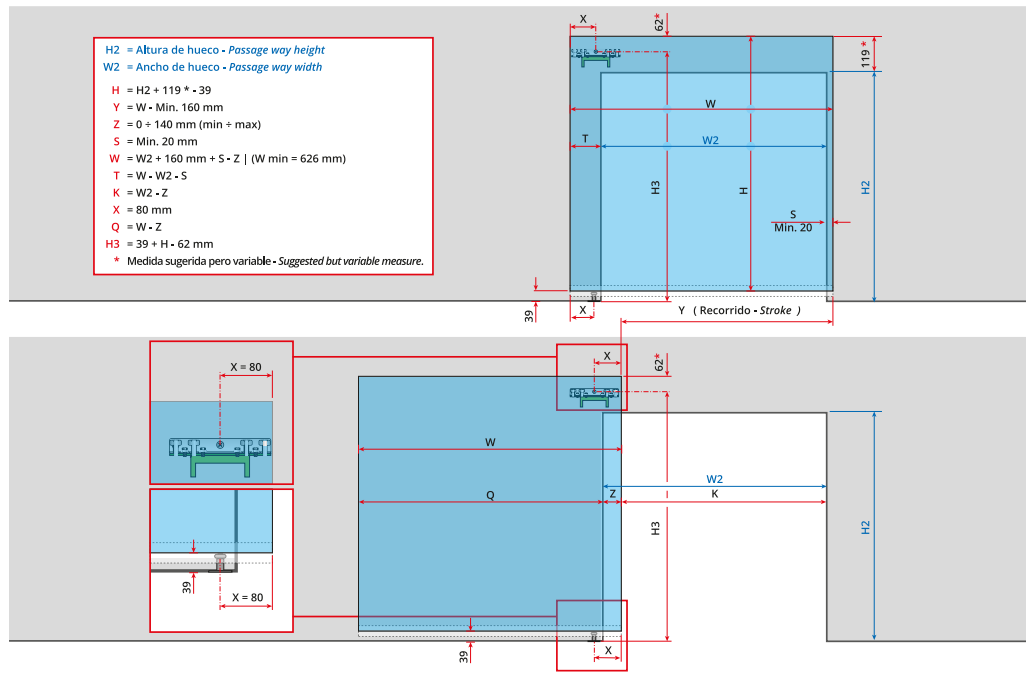

Corte de cristal según medida de puerta.

Coupe de verre.

Glass Cutting.

Taglio del vetro.

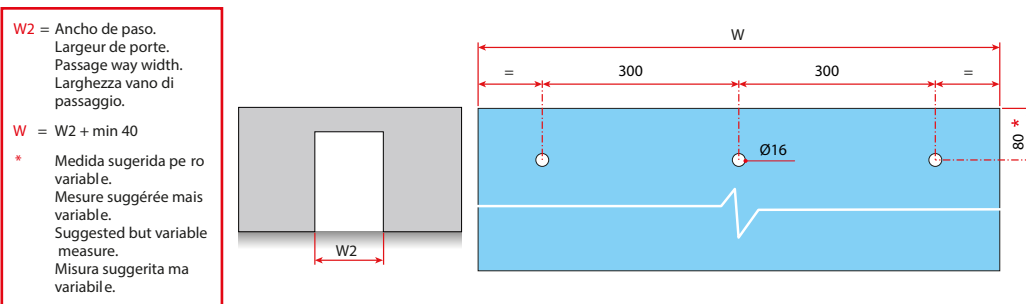

Cortar los elementos a la medida necesaria de puerta.

Couper les éléments à la taille nécessaire de la porte.

Cut the elements to the necessary size of door.

Tagliare gli elementi in base alle dimensioni della porta.

Carril superior:

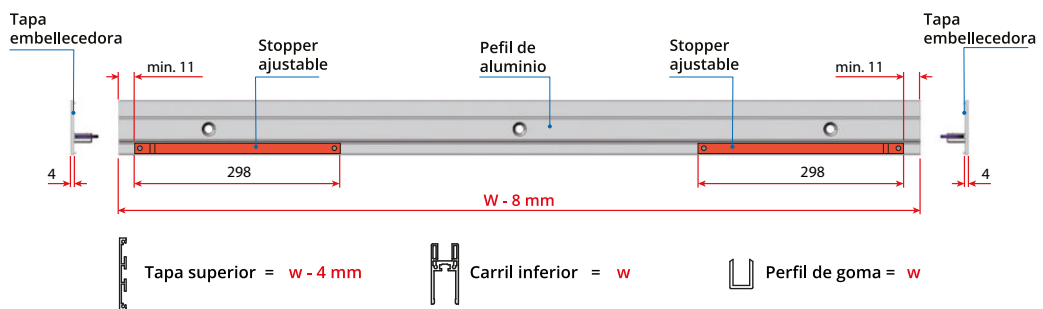

Fijación del cristal con el carril inferior.

Fixation du verre avec le rail inférieure.

Fixing the glass with the bottom track.

Fissaggio del vetro con il binario inferiore.

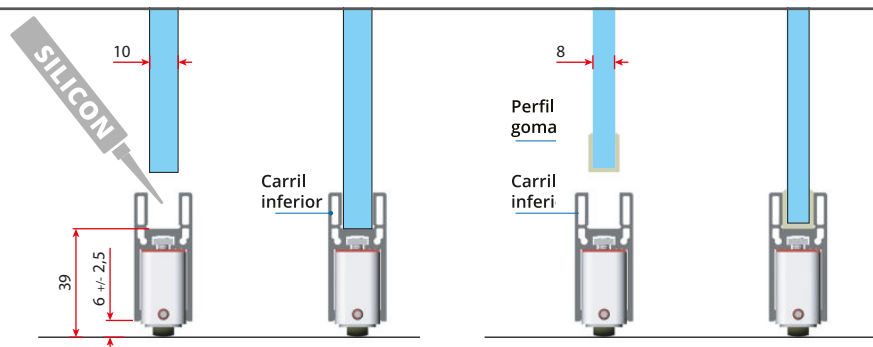

*CORREDERA RIMINI DATOS TÉCNICOS

Sistema de tipo A

$W = W2 + 40 \text{ mm}$

- *Medida sugerida pero variable.
- *Mesure suggérée mais variable.
- *Suggested but variable measure.
- *Misura suggerita ma variabile.

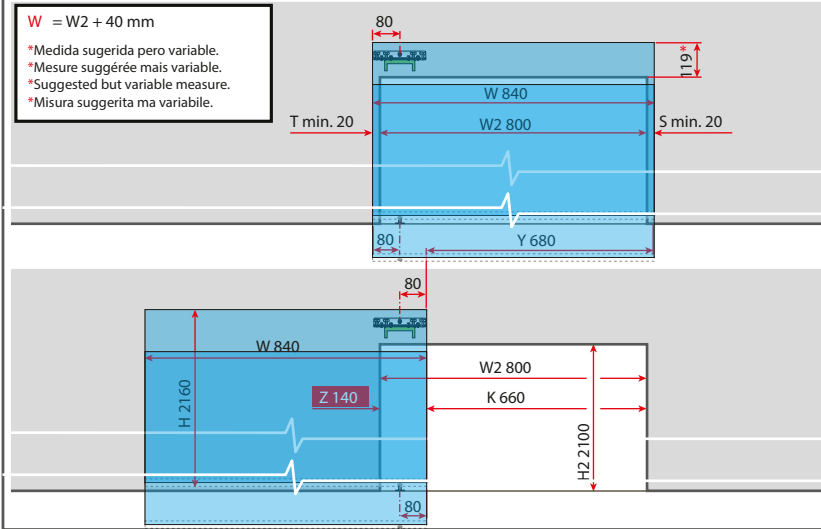

Posición A

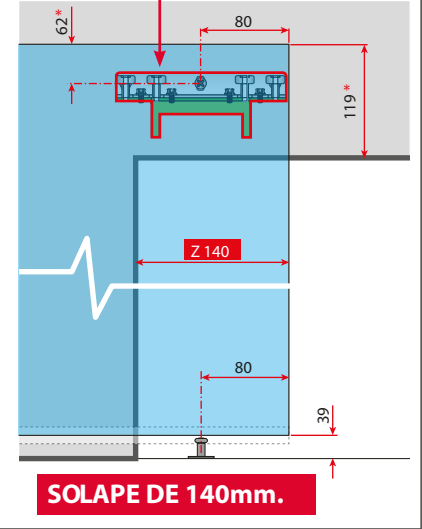

Sistema de tipo B

$W = W2 + 110 \text{ mm}$

- *Medida sugerida pero variable.
- *Mesure suggérée mais variable.
- *Suggested but variable measure.
- *Misura suggerita ma variabile.

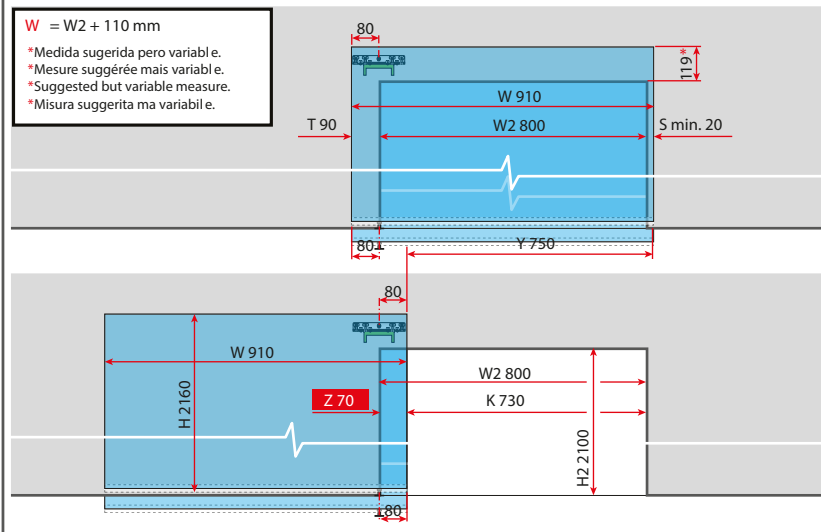

Posición B

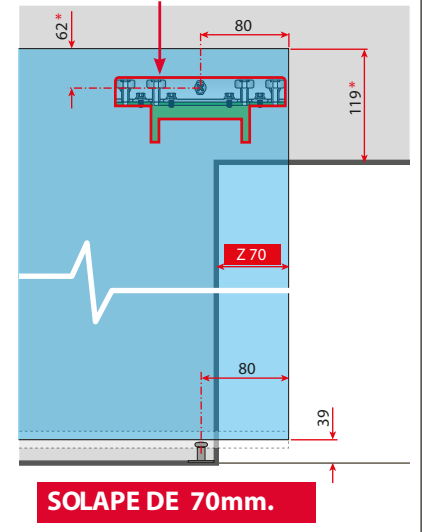

Sistema de tipo C

$W = W2 + 180 \text{ mm}$

- *Medida sugerida pero variable.
- *Mesure suggérée mais variable.
- *Suggested but variable measure.
- *Misura suggerita ma variabile.

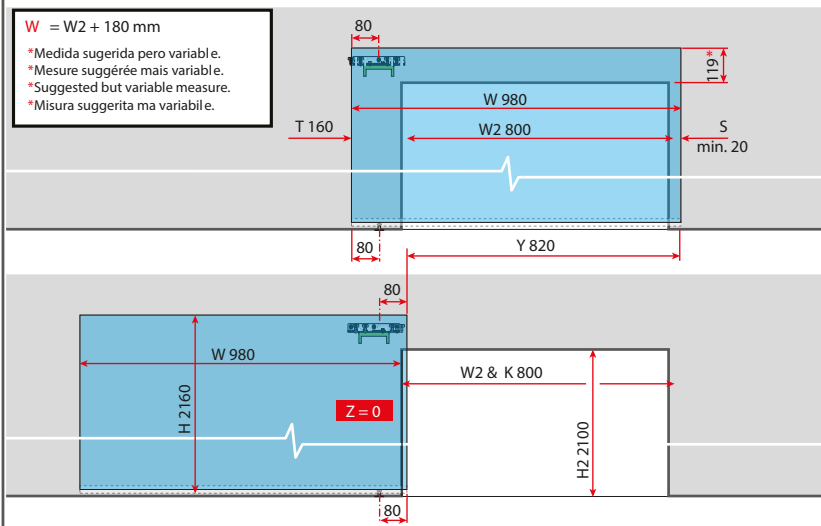

Posición C

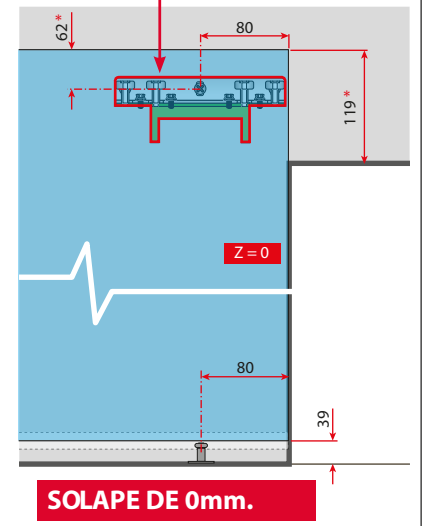

PLEGABLE

ALUMINIO E INOX
ALUMINIUM ET ACIER INOXYDABLE
ALUMINIUM AND STAINLESS STEEL
ALLUMINIO E ACCIAIO INOSSIDABILE

- espesor vidrio: 10-12 mm templado
- ancho maximo hoja: 960 mm
- alto maximo hoja recom.: 2600 mm
- peso max.: 80 kg/hoja
- se recomienda max. 6 hojas continuas
- precisa muescas en los vidrios.
- sin carril en el suelo
- sistema no estanco

- pods-limite porte: 80 kg
- large-limite porte: 960 mm
- Hauteur-limite porte: 2600 mm
- max. rec. 6 portes/kit
- verre 10-12 mm trempé
- encoches
- sans guide du sol
- no étanchéité
- weight max. door: 80 kg
- width max. door: 960 mm
- height max. door: 2600 mm
- max. rec. 6 doors/kit
- glass 10-12 mm tempered
- cut-out
- without floor guide
- not stagnancy
- peso max. porta: 80 kg
- larghezza max. porta: 960 mm
- altezza max. porta: 2600 mm
- max. rec. 6 porte/kit
- vetro 10-12 mm temperato
- Tacca nel vetro
- Senza guida a terra
- non a tenuta stagna

PRESUPUESTOS

1. escoger la configuración
2. indicar medida de hueco y alto.
3. indicar acabado (en stock plata mate)
4. enviar por e-mail ó fax la solicitud (si es posible con un croquis)

ESTIMATIONS

1. choisir la configuration
2. indiquer la taille de l'ouverture et de la hauteur.
3. indiquer finition (stock: aluminium anod.naturel)
4. envoyer par e-mail ou par le fax le demande (si possible avec un croquis)

QUOTATIONS

1. choose the configuration
2. indicate opening size and height.
3. indicate finish (aluminium natural anod. in stock)
4. send by e-mail or by fax the requirement (if possible with a sketch)

PREVENTIVI

1. scegliere la configurazione
2. indicare le dimensioni di apertura e l'altezza.
3. indicare finitura (stock: alluminio anod.naturale)
4. inviare via e-mail o fax la richiesta (se possibile con uno schizzo)



ref. 4482/



Al 5,8 m

GUÍA SUPERIOR
COULISSE HAUTE
UPPER TRACK
GUIDA SUPERIOR
4460/101

inox s.s. Al plas 80 kg/u

COJINETE
GALET
ROLLER
PATTINO SCORREVOLE
4465/000

inox s.s. Al 80 kg/u

GIRO SUPERIOR PIVOTANTE
PIVOT SUPERIEUR
UPPER PIVOTING HINGE
CERNIERA PIVOTANTE SUPERIORE
4466/000

inox s.s. Al 80 kg/u

GIRO INFERIOR PIVOTANTE
PIVOT INFERIEUR
BOTTOM PIVOTING HINGE
CERNIERA PIVOTANTE INFERIORE
4467/000

Al 3 m

CASACA VIDRIO
PROFIL VERRE
PROFILE GLASS
PROFILO VETRO
4461/101

Al 1,2 m

CASACA VIDRIO X CERRADURA
PROFIL VERRE X SERRURE
PROFILE GLASS X LOCK
PROFILO VETRO X SERRATURA
4462/001

inox s.s. Al Zn

CERRADURA DISTINTA LLAVE
SERRURE COMBINAISONS DIFFÉRENTES
LOCK DIFFERENT KEYED
SERRATURA COMBINAZIONI DISTINTE
4462/L01

MISMA LLAVE: CONSULTAR
MÊME COMBINAISON: CONSULTE
KEYD ALIKE: CONSULT
STESSA COMBINAZIONE: CONSULTARE

Al 1,2 m

CASACA VIDRIO X PESTILLO LATERAL
PROFIL VERRE X VERROULATÉRALE
PROFILE GLASS X LATERAL BOLT
PROFILO VETRO X CHIAVISTELLO LATERALE
4468/001

inox s.s. Al Zn

PESTILLO LATERAL
VERROULATÉRALE
LATERAL BOLT
CHIAVISTELLO LATERALE
4468/B01

inox s.s.

CUBILETE
GAÛCHE
STRIKE PATCH
CONTROSERRATURA
4463/022

inox s.s. plas Ø 25

ANCLAJE VIDRIO-CASACA 4461
CONNEXION VERRE-PERFIL 4461
CONNECTION GLASS-PROFIL 4461
CONNESSIONE VETRO-PROFILO 4461
4471/000

inox s.s. Al

BISAGRA X 4461
CHARNIERE X 4461
HINGE X 4461
CERNIERA X 4461
4469/001

inox s.s. Al

TAPA FINAL CASACA
EMBOUT X 4461
END-CAP X 4461
COPRITESTA X 4461
4470/001

inox s.s. plas

CEPILLO
BROSSER
BRUSH
SPAZZOLA
4474/200 12 mm

Al plas

TOPE SUELO
ARRETEZ DE PORTE DU SOL
DOOR STOPPER
STOP SUOLO
4464/022

inox s.s. plas

RETENCIÓN PUERTAS SUELO
RÉTENTION PORTES
DOORS RETENTION
RITENZIONE PORTE
4473/022

TORNILLOS
VIS
SCREWS
VITI
4477/000

LLAVE
OUTIL
TOOL x SCREWS
UTENSILE REGOLABILE x VITI
4472/034

KIT	4480/001	4481/001	4482/001	4483/001	4484/001	4485/001	4486/001	4487/001	4488/001	4489/001
PUERTAS PORTES DOORS PORTE	2	2+1	3	3+1	4	4+1	5	5+1	6	6+1
ANCHO mm LARGEUR WIDTH LARGHEZZA	1510	2490	2490	3460	3460	4440	4440	5400	5400	6380 max.
										consultar

KITS

4480/001
max. 1510 mm
2 puertas

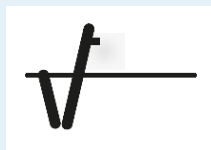

4465/000	cojinete carril sup.	1 u
4466/000	giro sup.	1 u
4469/001	bisagra	2 u
4467/000	giro inf.	1 u
4473/022	bloqueo puerta	1 u
4472/034	llave montaje	1 u
4461/101	casaca	2 m
4462/101	casaca + cerradura	1 u
4460/101	carril sup.	1,5 m
4463/022	cubilete	1 u
4464/022	tope suelo	1 u
4471/000	fijador vidrio/casaca	8 u
4474/000	cepillo	6 m
4470/001	tapas finales casaca	4 u
1833/109	tapajunta final	6 m
1834/109	tapajunta intermedio	3 m

KITS

4485/001
max. 4440 mm
4+1 puertas

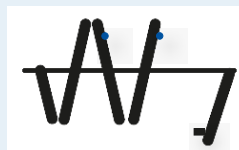

4465/000	cojinete carril sup.	3 u
4466/000	giro sup.	2 u
4469/001	bisagra	6 u
4467/000	giro inf.	2 u
4473/022	bloqueo puerta	4 u
4472/034	llave montaje	1 u
4461/101	casaca	6 m
4462/101	casaca + cerradura	1 u
4468/101	casaca + pestillo	2 u
4460/101	carril sup.	5,8 m
4463/022	cubilete	3 u
4464/022	tope suelo	2 u
4471/000	fijador vidrio/casaca	20 u
4474/000	cepillo	18 m
4470/001	tapas finales casaca	8 u
1833/109	tapajunta final	9 m
1834/109	tapajunta intermedio	9 m

4481/001
max. 2490 mm
2+1 puertas

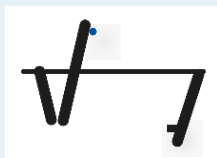

4465/000	cojinete carril sup.	1 u
4466/000	giro sup.	2 u
4469/001	bisagra	2 u
4467/000	giro inf.	2 u
4473/022	bloqueo puerta	2 u
4472/034	llave montaje	1 u
4461/101	casaca	3 m
4462/101	casaca + cerradura	1 u
4468/101	casaca x pestillo	1 u
4460/101	carril sup.	2,5 m
4463/022	cubilete	2 u
4464/022	tope suelo	2 u
4471/000	fijador vidrio/casaca	12 u
4474/000	cepillo	5 u
4470/001	tapas finales casaca	8 u
1833/109	tapajunta final	6 m
1834/109	tapajunta intermedio	3 m

4486/001
max. 4440 mm
5 puertas

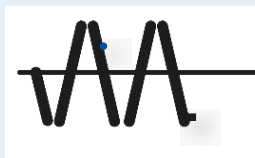

4465/000	cojinete carril sup.	4 u
4466/000	giro sup.	1 u
4469/001	bisagra	8 u
4467/000	giro inf.	1 u
4473/022	bloqueo puerta	1 u
4472/034	llave montaje	1 u
4461/101	casaca	7 m
4462/101	casaca + cerradura	1 u
4468/101	casaca + pestillo	1 u
4460/101	carril sup.	5,8 m
4463/022	cubilete	2 u
4464/022	tope suelo	1 u
4471/000	fijador vidrio/casaca	20 u
4474/000	cepillo	18 m
4470/001	tapas finales casaca	4 u
1833/109	tapajunta final	6 m
1834/109	tapajunta intermedio	12 m

4482/001
max. 2490 mm
3 puertas



4465/000	cojinete carril sup.	2
4466/000	giro sup.	1
4469/001	bisagra	4
4467/000	giro inf.	1
4473/022	bloqueo puerta	1
4472/034	llave montaje	1
4461/101	casaca	4
4462/101	casaca + cerradura	1
4460/101	carril sup.	2,5
4463/022	cubilete	1
4464/022	tope suelo	1
4471/000	fijador vidrio/casaca	12
4474/000	cepillo	5
4470/001	tapas finales casaca	4
1833/109	tapajunta final	6 m
1834/109	tapajunta intermedio	6 m

4487/001
max. 5400 mm
5+1 puertas



4465/000	cojinete carril sup.	4 u
4466/000	giro sup.	2 u
4469/001	bisagra	8 u
4467/000	giro inf.	2 u
4473/022	bloqueo puerta	2 u
4472/034	llave montaje	1 u
4461/101	casaca	8 m
4462/101	casaca + cerradura	1 u
4468/101	casaca + pestillo	2 u
4460/101	carril sup.	5,8 m
4463/022	cubilete	3 u
4464/022	tope suelo	2 u
4471/000	fijador vidrio/casaca	24 u
4474/000	cepillo	22 m
4470/001	tapas finales casaca	8 u
1833/109	tapajunta final	9 m
1834/109	tapajunta intermedio	12 m

4483/001
max. 3460 mm
3+1 puertas

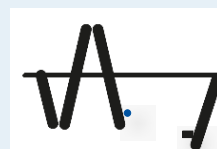

4465/000	cojinete carril sup.	2 u
4466/000	giro sup.	2 u
4469/001	bisagra	4 u
4467/000	giro inf.	2 u
4473/022	bloqueo puertas	2 u
4472/034	llave montaje	1 u
4461/101	casaca	5 m
4462/101	casaca + cerradura	1 u
4468/101	casaca + pestillo	1 u
4460/101	carril sup.	3,5 m
4463/022	cubilete	2 u
4464/022	tope suelo	2 u
4471/000	fijador vidrio/casaca	16 u
4474/000	cepillo	14 m
4470/001	tapas finales casaca	8 u
1833/109	tapajunta final	9 m
1834/109	tapajunta intermedio	6 m

4488/001
max. 5400 mm
6 puertas



4465/000	cojinete carril sup.	5 u
4466/000	giro sup.	1 u
4469/001	bisagra	10 u
4467/000	giro inf.	1 u
4473/022	bloqueo puerta	1 u
4472/034	llave montaje	1 u
4461/101	casaca	8 m
4462/101	casaca + cerradura	1 u
4468/101	casaca + pestillo	2 u
4460/101	carril sup.	5,8 m
4463/022	cubilete	3 u
4464/022	tope suelo	1 u
4471/000	fijador vidrio/casaca	24 u
4474/000	cepillo	22 m
4470/001	tapas finales casaca	4 u
1833/109	tapajunta final	6 m
1834/109	tapajunta intermedio	15 m

4484/001
max. 3460 mm
4 puertas

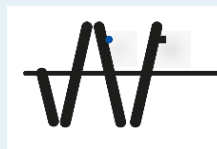

4465/000	cojinete carril sup.	3 u
4466/000	giro sup.	1 u
4469/001	bisagra	6 u
4467/000	giro inf.	1 u
4473/022	bloqueo puerta	1 u
4472/034	llave montaje	1 u
4461/101	casaca	5 m
4462/101	casaca + cerradura	1 u
4468/101	casaca + pestillo	1 u
4460/101	carril sup.	3,2 m
4463/022	cubilete	2 u
4464/022	tope suelo	1 u
4471/000	fijador vidrio	16 u
4474/000	cepillo	14 m
4470/001	tapas finales	4 u
1833/109	tapajunta final	6 m
1834/109	tapajunta intermedio	9 m

4489/001
max. 6380 mm
6+1 puertas

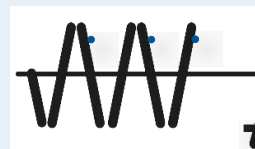

4465/000	cojinete carril sup.	5 u
4466/000	giro sup.	2 u
4469/001	bisagra	10 u
4467/000	giro inf.	2 u
4473/022	bloqueo puerta	2 u
4472/034	llave montaje	1 u
4461/101	casaca	9 m
4462/101	casaca + cerradura	1 u
4468/101	casaca + pestillo	3 u
4460/101	carril sup.	6,4 m
4463/022	cubilete	4 u
4464/022	tope suelo	2 u
4471/000	fijador vidrio	28 u
4474/000	cepillo	26 m
4470/001	tapas finales	8 u
1833/109	tapajunta final	9 m
1834/109	tapajunta intermedio	15 m

PLEGABLE DESPLAZADA

ALUMINIO E INOX
ALUMINIUM ET ACIER INOXYDABLE
ALUMINIUM AND STAINLESS STEEL
ALLUMINIO E ACCIAIO INOSSIDABILE

- espesor vidrio: 10-12 mm templado
- ancho maximo hoja: 960 mm
- alto maximo hoja recom.: 2600 mm
- peso max.: 80 kg/hoja
- se recomienda max. 6 hojas continuas
- precisa muestas en los vidrios.
- sin carril en el suelo
- sistema no estanco

- pods-limite porte: 80 kg
- large-limite porte: 960 mm
- Hauteur-limite porte: 2600 mm
- max. rec. 6 portes/kit
- verre 10-12 mm trempé
- encoches
- avec guide du sol
- no étancheité
- weight max. door: 80 kg
- width max. door: 960 mm
- height max. door: 2600 mm
- max. rec. 6 doors/kit
- glass 10-12 mm tempered
- cut-out
- with floor guide
- not stagnancy
- peso max. porta: 80 kg
- larghezza max. porta: 960 mm
- altezza max. porta: 2600 mm
- max. rec. 6 porte/kit
- vetro 10-12 mm temperato
- tacca nel vidrio
- con guida a terra
- non a tenuta stagna

PRESUPUESTOS

1. escoger la configuración
2. indicar medida de hueco y alto.
3. indicar acabado (en stock plata mate)
4. enviar por e-mail ó fax la solicitud (si es posible con un croquis)

ESTIMATIONS

1. choisir la configuration
2. indiquer la taille de l'ouverture et de la hauteur.
3. indiquer finition (stock: aluminium anod.naturel)
4. envoyer par e-mail ou par le fax le demande (si possible avec un croquis)

QUOTATIONS

1. choose the configuration
2. indicate opening size and height.
3. indicate finish (aluminium natural anod. in stock)
4. send by e-mail or by fax the requirement (if possible with a sketch)

PREVENTIVI

1. scegliere la configurazione
2. indicare le dimensioni di apertura e l'altezza.
3. indicare finitura (stock: alluminio anod.naturale)
4. inviare via e-mail o fax la richiesta (se possibile con uno schizzo)



Al L 5,8 m

GUÍA SUPERIOR
COULISSE HAUTE
UPPER TRACK
GUIDA SUPERIOR

4460/101



inox s.s. Al plas 80 kg/u

COJINETE SUPERIOR
GALET SUPERIEUR

UPPER ROLLER
PATTINO SCORREVOLE SUPERIORE

4465/000



inox s.s. Al 80 kg/u

GIRO SUPERIOR PIVOTANTE
PIVOT SUPERIEUR

UPPER PIVOTING HINGE
CERNIERA PIVOTANTE SUPERIORE

4466/000



inox s.s. Al 80 kg/u

GIRO INFERIOR PIVOTANTE
PIVOT INFERIEUR

BOTTOM PIVOTING HINGE
CERNIERA PIVOTANTE INFERIORE

4467/000



Al L 3 m

CASACA VIDRIO
PROFIL VERRE

PROFILE GLASS
PROFILO VETRO

4461/101



Al L 1,2 m

CASACA VIDRIO X CERRADURA
PROFIL VERRE X SERRURE

PROFILE GLASS X LOCK
PROFILO VETRO X SERRATURA

4462/001



inox s.s. Al Zn

CERRADURA DISTINTA LLAVE
SERRURE COMBINAISONS DIFFÉRENTES

LOCK DIFFERENT KEYED
SERRATURA COMBINAZIONI DISTINTE

4462/L01



inox s.s. Al Zn

MISMA LLAVE: CONSULTAR
MÊME COMBINAISON: CONSULTE

KEYD ALIKE: CONSULT
STESSA COMBINAZIONE: CONSULTARE

4462/001



Al L 1,2 m

CASACA VIDRIO X PESTILLO LATERAL
PROFIL VERRE X VERROU LATERALE

PROFILE GLASS X LATERAL BOLT
PROFILO VETRO X CHIAVISTELLO LATERALE

4468/001



inox s.s. Al Zn

PESTILLO LATERAL
VERROU LATERALE

LATERAL BOLT
CHIAVISTELLO LATERALE

4468/B01

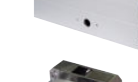

inox s.s.

CUBILETE
GAUCHE

STRIKE PATCH
CONTROSERRATURA

4463/022



inox s.s. plas Ø 25

ANCLAJE VIDRIO-CASACA 4461
CONNEXION VERRE-PERFIL 4461

CONNEXION GLASS-PERFIL 4461
CONNESSIONE VETRO-PROFILO 4461

4471/000



inox s.s. Al

BISAGRA X 4461
CHARNIÈRE X 4461

HINGE X 4461
CERNIERA X 4461

4469/001



inox s.s. Al

TAPA FINAL CASACA
EMBOUT X 4461

END-CAP X 4461
COPRITESTA X 4461

4470/001



inox s.s. plas

CEPILLO
BROSSER

BRUSH
SPAZZOLA

4474/200 12 mm



Al plas

TOPE SUELO
ARRETEZ DE PORTE DU SOL

DOOR STOPPER
STOP SUOLO

4464/022



inox s.s. plas

RETENCIÓN PUERTAS SUELO
RÉTENTION PORTES

DOORS RETENTION
RITENZIONE PORTE

4473/022



TORNILLOS
VIS

SCREWS
VITI

4477/000



LLAVE
OUTIL

TOOL x SCREWS
UTENSILE REGOLABILE x VITI

4472/034



CARRIL INFERIOR

Las puertas de la Plegable Desplazada necesitan el carril 4478 empotrado en el suelo y un cojinete inferior 4479 cada 2 hojas.
 Les portes du Plegable Desplazada besoin du guidage inférieure 4478 incorporé dans le sol et un rouleau inférieure 4479 chaque deux portes.
 The Plegable Desplazada's doors need the bottom guide 4478 embedded in the floor and one bottomroller 4479 every 2 doors.
 Le porte della Plegable Desplazada richiedono la guida inferiore 4478 incassata nel suolo e un cuscinetto 4479 ogni 2 porte



Al 5,8 m 28x20

GUÍA INFERIOR EMPOTRABLE
COULISSE INFÉRIEUR D'ENCASTREMENT
BOTTOM TRACK RECESSED
GUIDA INFERIORE INCASSO
4478/101



inox s.s. Al plas

COJINETE INFERIOR
GALET INFÉRIEUR
BOTTOM ROLLER
PATTINO SCORREVOLE INFERIORE
4479/000

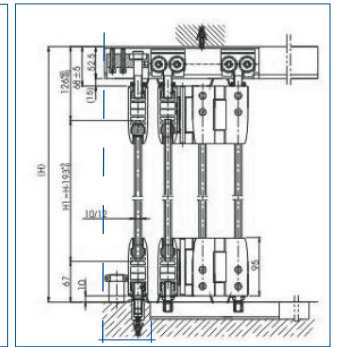
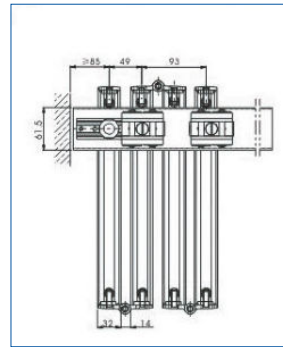

90

MODELO	4480/D01	4481/D01	4484/D01	4485/D01	4488/D01	4489/D01
HOJAS	2	2+1	4	4+1	6	6+1
	1800	2700	3600	4500	5400	6300

Se recomienda dejar una separación de 90 mm para colocar el giro inferior 4467 de la primera puerta
 Nous recommandons de laisser un espace de 90 mm pour positionner le pivot inférieur 4467 de la première porte
 We recommend leaving a gap of 90 mm to position the lower pivot 4467 of the first door
 Si raccomandanda lasciare uno spazio di 90 mm per collocare la cerniera inferiore della prima porta

KITS

4480/D01
max. 1800 mm
2 puertas

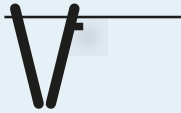

- 4465/000 cojinete carril sup. 1 u
- 4479/000 cojinete carril inf. 1 u
- 4466/000 giro sup. 1 u
- 4469/001 bisagra 2 u
- 4467/000 giro inf. 1 u
- 4473/022 bloqueo puerta 1 u
- 4472/034 llave montaje 1 u
- 4461/101 casaca 3 m
- 4462/101 casaca + cerradura 1 u
- 4460/101 carril sup. 2 m
- 4478/101 carril inf. 1 m
- 4463/022 cubilete 1 u
- 4464/022 tope suelo 1 u
- 4471/000 fijador vidrio/casaca 8 u
- 4474/000 cepillo 8 m
- 4470/001 tapas finales casaca 4 u
- 4477/000 tacos y tornillos 4 u
- 1833/109 tapajunta final 6 m
- 1834/109 tapajunta intermedio 3 m

KITS

4485/D01
max. 4500 mm
4+1 puertas

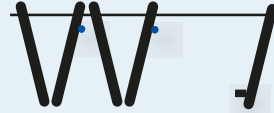

- 4465/000 cojinete carril sup. 2 u
- 4479/000 cojinete carril inf. 2 u
- 4466/000 giro sup. 2 u
- 4469/001 bisagra 2 u
- 4467/000 giro inf. 2 u
- 4473/022 bloqueo puerta 2 u
- 4472/034 llave montaje 1 u
- 4461/101 casaca 7 m
- 4462/101 casaca + cerradura 1 u
- 4468/101 casaca + pestillo 2 u
- 4460/101 carril sup. 5 m
- 4478/101 carril inf. 4 m
- 4463/022 cubilete 3 u
- 4464/022 tope suelo 2 u
- 4471/000 fijador vidrio/casaca 20 u
- 4474/000 cepillo 20 m
- 4470/001 tapas finales casaca 8 u
- 4477/000 tacos y tornillos 20 u
- 1833/109 tapajunta final 9 m
- 1834/109 tapajunta intermedio 9 m

4481/D01
max. 2700 mm
2+1 puertas



- 4465/000 cojinete carril sup. 1 u
- 4479/000 cojinete carril inf. 1 u
- 4466/000 giro sup. 2 u
- 4469/001 bisagra 2 u
- 4467/000 giro inf. 2 u
- 4473/022 bloqueo puerta 2 u
- 4472/034 llave montaje 1 u
- 4461/101 casaca 4 m
- 4462/101 casaca + cerradura 1 u
- 4468/101 casaca + pestillo 1 u
- 4460/101 carril sup. 3 m
- 4478/101 carril inf. 1 m
- 4463/022 cubilete 2 u
- 4464/022 tope suelo 2 u
- 4471/000 fijador vidrio/casaca 12 u
- 4474/000 cepillo 12 m
- 4470/001 tapas finales casaca 8 u
- 4477/000 tacos y tornillos 8 u
- 1833/109 tapajunta final 9 m
- 1834/109 tapajunta intermedio 3 m

4488/D01
max. 5400 mm
6 puertas



- 4465/000 cojinete carril sup. 3 u
- 4479/000 cojinete carril inf. 3 u
- 4466/000 giro sup. 1 u
- 4469/001 bisagra 10 u
- 4467/000 giro inf. 1 u
- 4473/022 bloqueo puerta 1 u
- 4472/034 llave montaje 1 u
- 4461/101 casaca 9 m
- 4462/101 casaca + cerradura 1 u
- 4468/101 casaca + pestillo 2 u
- 4460/101 carril sup. 5,8 m
- 4478/101 carril inf. 5,8 m
- 4463/022 cubilete 3 u
- 4464/022 tope suelo 1 u
- 4471/000 fijador vidrio/casaca 24 u
- 4474/000 cepillo 24 m
- 4470/001 tapas finales casaca 4 u
- 4477/000 tacos y tornillos 24 u
- 1833/109 tapajunta final 6 m
- 1834/109 tapajunta intermedio 15 m

4484/D01
max. 3600 mm
4 puertas



- 4465/000 cojinete carril sup. 2 u
- 4479/000 cojinete carril inf. 2 u
- 4466/000 giro sup. 1 u
- 4469/001 bisagra 4 u
- 4467/000 giro inf. 1 u
- 4473/022 bloqueo puerta 1 u
- 4472/034 llave montaje 1 u
- 4461/101 casaca 6 m
- 4462/101 casaca + cerradura 1 u
- 4468/101 casaca + pestillo 1 u
- 4460/101 carril sup. 4 m
- 4478/101 carril inf. 3 m
- 4463/022 cubilete 2 u
- 4464/022 tope suelo 1 u
- 4471/000 fijador vidrio/casaca 8 u
- 4474/000 cepillo 16 m
- 4470/001 tapas finales casaca 4 u
- 4477/000 tacos y tornillos 16 u
- 1833/109 tapajunta final 6 m
- 1834/109 tapajunta intermedio 9 m

4489/D01
max. 6400 mm
6+1 puertas



- 4465/000 cojinete carril sup. 3 u
- 4479/000 cojinete carril inf. 3 u
- 4466/000 giro sup. 2 u
- 4469/001 bisagra 2 u
- 4467/000 giro inf. 2 u
- 4473/022 bloqueo puerta 2 u
- 4472/034 llave montaje 1 u
- 4461/101 casaca 10 m
- 4462/101 casaca + cerradura 1 u
- 4468/101 casaca + pestillo 3 u
- 4460/101 carril sup. 6,5 m
- 4478/101 carril inf. 5,8 m
- 4463/022 cubilete 4 u
- 4464/022 tope suelo 2 u
- 4471/000 fijador vidrio/casaca 20 u
- 4474/000 cepillo 26 m
- 4470/001 tapas finales casaca 8 u
- 4477/000 tacos y tornillos 30 u
- 1833/109 tapajunta final 9 m
- 1834/109 tapajunta intermedio 15 m

* APILPLUS

Puertas correderas apilables
en parking para vidrio templado

Aluminio anodizado y acero INOX
Peso max: 100 kg/hoja
Vidrio: 10-12 mm
Alto max. hoja: 3,5 m (12 mm)

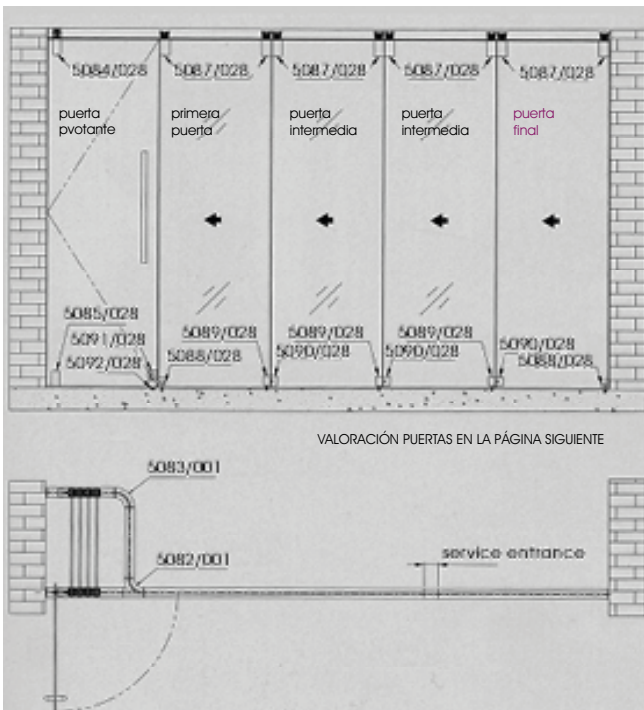

GUÍA SUPERIOR
COULISSE HAUTE
UPPER TRACK
GUIDA SUPERIOR
*5080/101

PL. MATE	INOX BR
ANOD. M	INOX POL
AN. CHR	P. S.S.
AN. OPAC	INOX LUC
01	22

Al	5 m	€/m
----	-----	-----

*o



ENTRADA PARKING 90°
ENTRÉE DU PARKING 90°
PARKING ENTRANCE 90°
ENTRATA PARCHEGGIO 90°
*5081/001 derecha
*5082/001 izquierda

Al	€/u
----	-----

*o

*o



GUÍA SUPERIOR CURVA 90°
COULISSE HAUTE COURBE 90
BEND UPPER TRACK 90°
GUIDA SUPERIORE CURVA 90°
*5083/001

Al	€/u
----	-----

*o



HERRAJE SUPERIOR
PENTURE HAUTE
TOP PIVOTING HINGE
CERNIERA SUPERIORE
PIVOTANTE
*5084/022

inox s.s.	10-12mm	€/u
-----------	---------	-----

*o



HERRAJE INFERIOR
PENTURE BASSE
BOTTOM PIVOT HINGE
CERNIERA INFERIORE PIVOTANTE
*5085/022 leva alemana
broches aleman, German pin, perno tedesco

inox s.s.	10-12mm	€/u
-----------	---------	-----

*o



GIRO INFERIOR LEVA ALEMANA
CRAPAUDINE BASSE BROCHES GER.
FLOOR PIVOT GERMAN PIN
GIRO INFERIORE PERNO TEDESCO
*5086/022

inox s.s.	€/u
-----------	-----

*o



COJINETE SUPERIOR
GALET SUPERIEUR
UPPER ROLLER
PATTINO SCORREVOLE SUPERIORE
*5087/022

inox s.s.	10-12mm	€/u
-----------	---------	-----

*o



PESTILLO INFERIOR CIERRE FRONTAL
VERROU INFÉRIEUR
BOTTOM BOLT
CHIAVISTELLO INFERIORE
*5088/022

inox s.s.	10-12mm	€/u
-----------	---------	-----

*o



PESTILLO INFERIOR CIERRE LATERAL
VERROU INFÉRIEUR
BOTTOM BOLT
CHIAVISTELLO INFERIORE
*5089/022

inox s.s.	10-12mm	€/u
-----------	---------	-----

*o



CONTRAPESTILLO
VERROU INFÉRIEUR
BOTTOM BOLT
CHIAVISTELLO INFERIORE
*5090/022

inox s.s.	10-12mm	€/u
-----------	---------	-----

*o



CERRADURA DISTINTA LLAVE
SERRURE COMBINAISONS
DIFFÉRENTES
LOCK DIFFERENT KEYED
SERRATURA COMBINAZIONI DISTINTE
*5091/022

inox s.s.	10-12mm	€/u
-----------	---------	-----

*o



CONTRAPESTILLO
VERROU INFÉRIEUR
BOTTOM BOLT
CHIAVISTELLO INFERIOR
*5092/022

inox s.s.	€/u
-----------	-----

*o

CÁLCULO PRECIO PUERTAS

- 1 puerta pivotante (tirador no incluido)
- 1 primera puerta
- 1 puerta final
- X puertas intermedias en función del hueco

Ejemplo: hueco: 4 m y 4 puertas
(1 pivotante + 3 corederas que tienen el mismo precio)

1 x 5095/022: 180 x 1 = 180
 1 x 5096/022: }
 1 x 5097/022: } 320 x 3 = 960
 1 x 5098/022: }
 total = 1140

Ejemplo: hueco: 10 m y 10 puertas
(1 pivotante + 9 corederas que tienen el mismo precio)

1 x 5095/022: 180 x 1 = 180
 1 x 5096/022: }
 7 x 5097/022: } 320 x 9 = 2880
 1 x 5097/022: }
 total = 3060

KITS

INOX BR INOX POLI P.S.S. INOX LUC 22	INOX BR INOX POLI P.S.S. INOX LUC 22	INOX BR INOX POLI P.S.S. INOX LUC 22	INOX BR INOX POLI P.S.S. INOX LUC 22
PUERTA PIVOTANTE VERROU INFÉRIEUR BOTTOM BOLT CHIAVISTELLO INFERIORE 5084 X 1 5085 X 1 5086 X 1 5091 X 1 5092 X 1 *5095/022	PRIMERA PUERTA VERROU INFÉRIEUR BOTTOM BOLT CHIAVISTELLO INFERIORE 5087 X 2 5088 X 1 5089 X 1 *5096/022	PUERTA INTERMEDIA VERROU INFÉRIEUR BOTTOM BOLT CHIAVISTELLO INFERIORE 5087 X 2 5089 X 1 5090 X 1 *5097/022	PUERTA INTERMEDIA VERROU INFÉRIEUR BOTTOM BOLT CHIAVISTELLO INFERIORE 5087 X 2 5088 X 1 5090 X 1 *5098/022
*o €/u	*o €/u	*o €/u	*o €/u

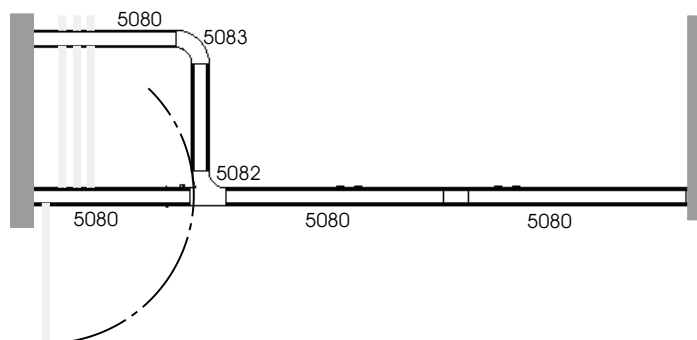

CÁLCULO PRECIO CARRIL

medida hueco + 1 m x precio €/ml carril
 curva 90° x precio curva entrada parking (der/izq)

Ejemplo: hueco: 4 m y 4 puertas (1 pivotante+3 corederas)

carril 5080/101: 5 x 75 = 375
 curva 90° 5083/001: 1 x 155
 entrada parking: 5082/001: 1 x 240
 Total carril = 770

Ejemplo: hueco: 10 m y 10 puertas
(1 pivotante+9 corederas)

carril 5080/101: 11 x 75 = 825
 curva 90° 5083/001: 1 x 155
 entrada parking: 5082/001: 1 x 240
 Total carril = 1220



cotek.

PUERTAS

HERRAJES PUERTAS ABATIBLES

GAMA PREMIUM

HERRAJES ALTA GAMA - PIVOTANTE SIENA

KITS Y COMPONENTES
MEDIDAS
MECANIZACIÓN
UNIONES

HERRAJES ALTA GAMA - FRENO AMSTERDAM FRENO MIAMI FRENO BOSTON FRENO PRAGA FRENO OPORTO

FRENOS Y BISAGRAS HIDRÁULICAS Y AUTOMÁTICAS -

RIO HIDRÁULICA
ATLANTA
MALLORCA HIDRÁULICA
ZURICH
SUIZA
GAUDÍ
VERNA
LUGO
MENORCA

FRENOS Y BISAGRAS - FRENOS IMPORTACIÓN PLINTO MÁLAGA MARINA ACCESORIOS COMUNES LYON VIENA GALICIA BONN

DIVISORIAS

PERFILES SELLADORES PUERTAS

HERRAJES FIJOS

GAMA PREMIUM

HERRAJES ALTA GAMA - SMART-LOCKS

CERRADURAS - CERRAD. MAGNÉTICAS CERRAD. CORREDERAS CIERRE LAVABOS MANILLA MONTSE MÓNICA SONIA MARTA

TIRADORES, POMOS Y UÑEROS

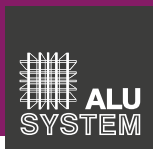

PIVOTANTE SIENA

SIENA - PUERTA PIVOTANTE

OB ON OO OP

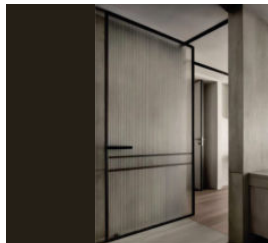

PUERTA DE ALUMINIO SIN FRENO EMPOTRADO EN EL PERIF.
porte en aluminium avec frein intégré
aluminium door with built-in brake
porta in alluminio con freno incorporato

Añadir el tipo de freno necesario (no incluido en el precio del kit).

Se sirve sin vidrio

8-10 mm Alto max. 3M

5404/00.

HASTA 100CM

OB ON OO OP

5404/01.

MÁS DE 100CM

NOVEDAD

SIENA 5404/00. PUERTA DE HASTA 100 componentes:

(X1) 5405/0..
(X2) 5406/0..
(X4) 5407/0..

(X1) 5408/20.
(X2) 5208/30.

SIENA 5404/01. PUERTA DE MÁS DE 100 componentes:

(X2) 5405/0..
(X2) 5406/0..
(X4) 5407/0..

(X1) 5408/20.
(X2) 5208/30.

COMPONENTES SIENA

OB ON OO OP O9



1SET FRENO HIDRÁULICO CON EJE DESCENTRADO+PUNTO DE GIRO. ROTACION DE PUERTA 180°

8-10 mm

Inx 304

5400/000

OB ON OO OP O9

1SET FRENO HIDRÁULICO CON EJE CENTRADO+PUNTO DE GIRO. ROTACION DE PUERTA 360°

8-10 mm

Inx 304

5403/000

PERFIL SUPERIOR E INFERIOR
kit de barras de refort verticales
vertical rebar kit
kit barre di rinforzo verticali

8-10 mm 2M

Inx 304

5405/2..

PERFIL LATERAL (DERECHA-IZQUIERDA)
kit lateral pour porte mobile verre-mur
Side kit for mobile door glass-wall
kit laterale porta mobile vetro-parete

8-10 mm 3M

Inx 304

5406/3..

CONECTOR CON 3 TORNILLOS
roulements carrés
square bearings
cuscinetti quadrati

8-10 mm

5407/000

SELLADOR PVC
kit de guidage inférieur
lower guide kit
kit guida inferiore

8 mm 200 cm SFL-072

5408/20N

8 mm 230 cm SFL-075

5408/30N

PUNTA CUÑA
pointe de coin
wedge tip
punto di cuneo

3M

5409/309

PERFIL ALUMINIO PARA CRISTAL-PUERTA DE PANEL JAPONÉS

4M

5127/30.

CERRADURA CON MANETA Y CONTRACERRADURA A PARED (CON CONDENA)

8 mm

5218/00N

CERRADURA CON MANETA Y CONTRACERRADURA A PARED (CON LLAVE)

3M

5217/00N

CERRADURA SMART-LOCK CANTÓN
serrure smart-lock Cantón
smart-lock for Cantón
serratura smart-lock Cantón

8 mm

5541/00N

MEDIDAS MARCOS Y VIDRIO

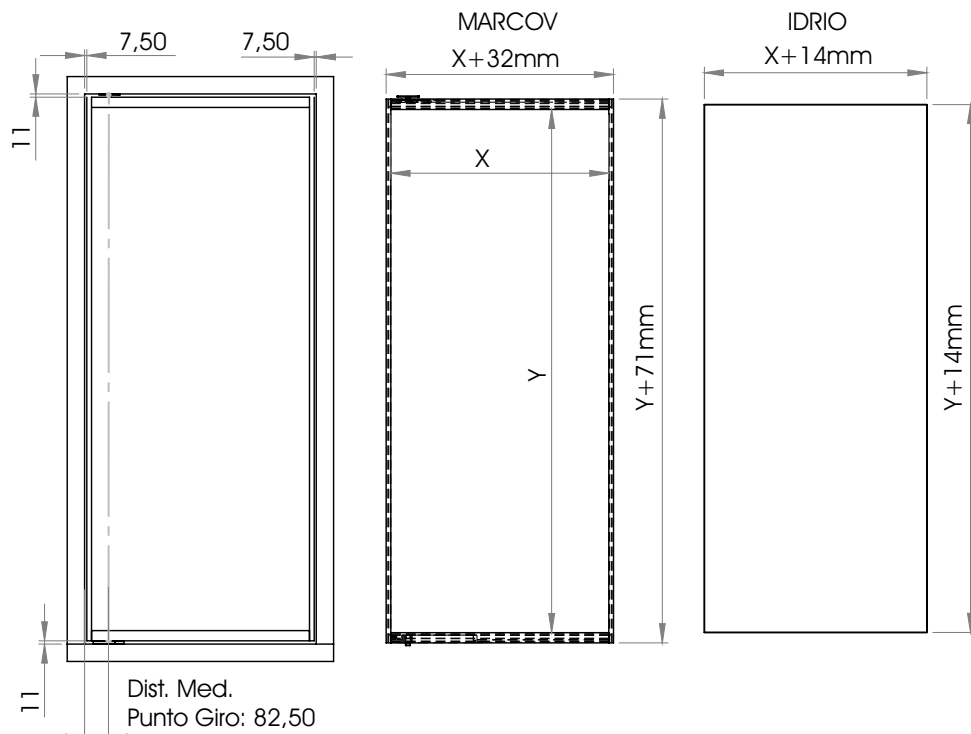

MECANIZADOS DE LOS PERFILES HORIZONTALES

PARTE DE ARRIBA

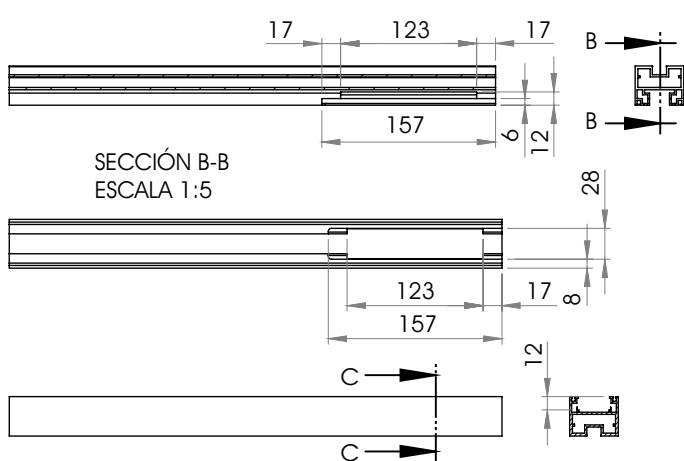

PARTE DE ABAJO

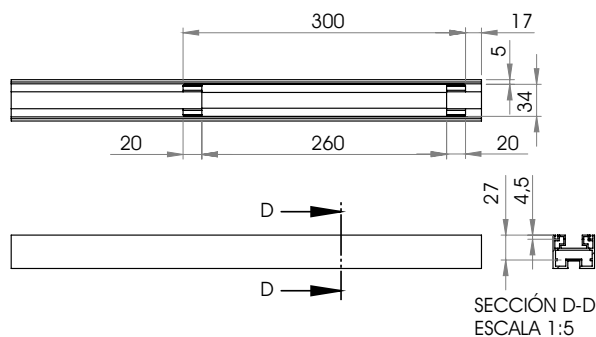

UNIÓN DE LOS MARCOS CON ESCUADRAS (4 ESQUINAS)

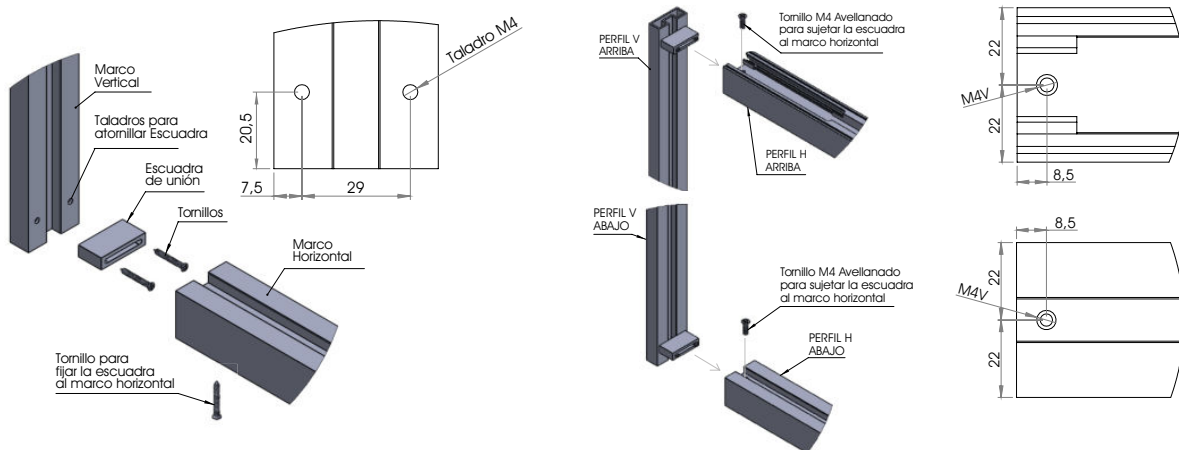

FRENO AMSTERDAM

HIDRÁULICO

Freno pivotante sin empotrar

Herraje superior

- Penture haute
- Top pivoting hinge
- Cerniera superiore pivotante

SET COMPLETO DE HERRAJE Y GIRO SUPERIOR

€/u

1536/0..

28 22 0N

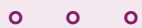

Freno hidráulico sin empotrar para interiores

- Ferme-porte hydraulique sans creusement utilisation en intérieur
- Hidraulic spring floor no digging for indoor use
- Chiudiporta idraulico senza incasso per uno interno

€/u

1535/0..

28 22 0N

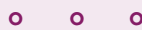

stop
0°-90°-180°

Herraje superior para vidrio fijo

- ferrure supérieure verre fixe
- Upper fitting fixed glass
- raccordo superiore vetro fisso

€/u

1534/0..

28 22 0N



- ix** Inox 304 190X70 mm
- 100 kg/u
- Ancho máximo 100 cm
- Testado 500.000 ciclos
- 8-12 mm

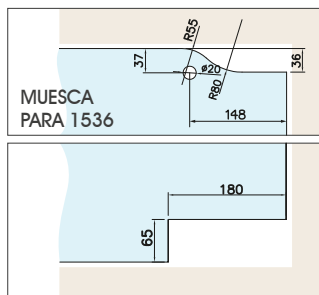
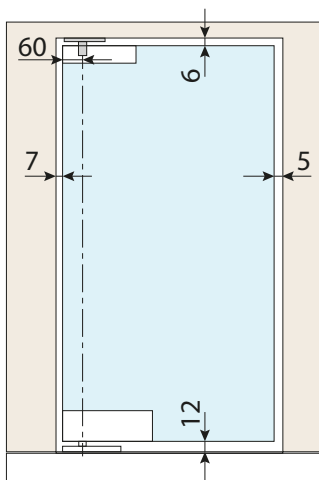

- TESTADO 500.000 CICLOS
- GARANTÍA 3 AÑOS
- TAXA DE REPOSICIÓN DEL 0,5%



FRENO MIAMI

HIDRÁULICO FUERZA 5

Freno pivotante sin empotrar

€/u

5340/0..

28 22 0N



Freno pivotante sin empotrar

- Frein de pivot non intégré
- Non-embedded pivot brake
- Freno a perno non incorporato



Pulido

€/u

5342/0..

28 22 0N



Herraje superior (para Miami y Boston)

- Frein de pivot non intégré
- Non-embedded pivot brake
- Freno a perno non incorporato



€/u

5343/0..

28 0N



Giro superior (para Miami y Boston)

- Frein de pivot non intégré
- Non-embedded pivot brake
- Freno a perno non incorporato



FUERZA 5

ix Inox 316

- Resistencia al viento amortiguación hidráulica de alto rendimiento

- ⊛ 1. Ángulo abierto: 140° doble acción
- 2. Sección de retención de puerta abierta: 90° y 140°-120°
- 3. Dos velocidades ajustables
- Válvula 1: 90°-0°
- Válvula 2: 30°-0°

- 150 kg/u
- 8-15 mm
- 500.000 ciclos
- Ancho máx. 120 cm
- Alto máx. 240 cm

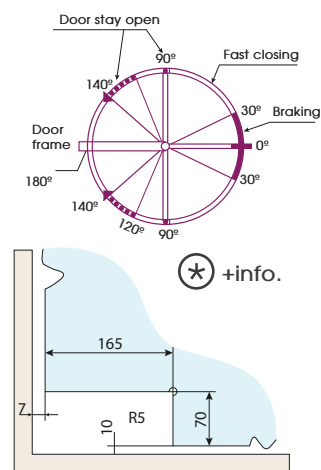
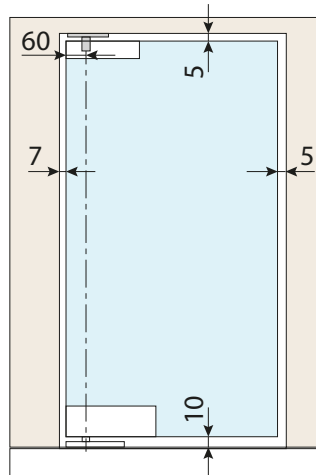

FRENO BOSTON EXTERIORES FUERZA 7

Freno hidráulico pivotante sin empotrar

€/u

5341/0..

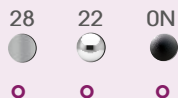

Satinado



Freno pivotante sin empotrar

- Frein de pivot non intégré
- Non-embedded pivot brake
- Freno a perno non incorporato



Pulido

€/u

5342/0..

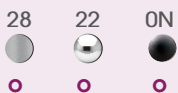

Herraje superior (para Miami y Boston)

- Frein de pivot non intégré
- Non-embedded pivot brake
- Freno a perno non incorporato



€/u

5343/0..



Giro superior (para Miami y Boston)

- Frein de pivot non intégré
- Non-embedded pivot brake
- Freno a perno non incorporato



FUERZA 7

ix Inox 316

- A prueba de viento fuerte, resistencia de grado 7, seguro y fiable
- Se puede utilizar para exteriores.
- Vida útil ultralarga. La garantía de calidad, seguro y duradero.
- Fácil instalación.
- Carga estable. Diseño compacto con gran capacidad de carga.

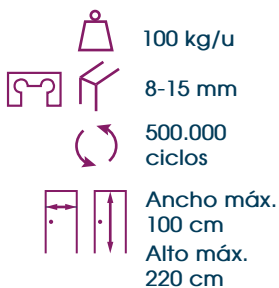

1. Ángulo abierto: 120° doble acción
 2. Sección de retención de puerta abierta: 90°
 3. Dos velocidades ajustables
- Válvula 1: 90°-30°
Válvula 2: 30°-0°

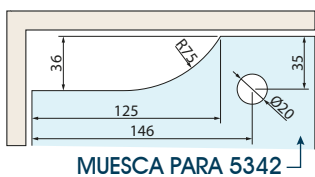

MUESCA PARA 5342

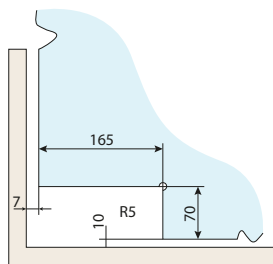

BISAGRA PRAGA TODA DE INOX

Bisagra hidráulica a pared con retención

€/set de 2u.

Set 2 bisagras

5325/0..

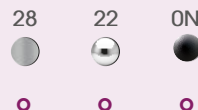

Bisagra hidráulica PARED - VIDRIO

- Penture haute
- Top pivoting hinge
- Cerniera superiore pivotante



ix Inox 304

30 kg/u



8-12 mm

Ancho máx.

1000mm

Alto máx.

2200mm

50.000 ciclos

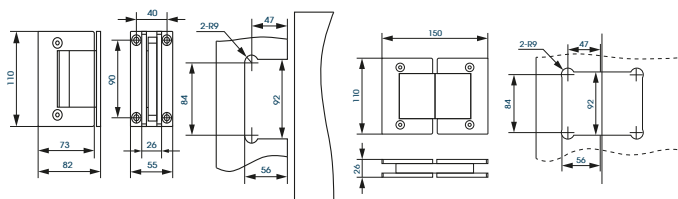

BISAGRA OPORTO

Bisagra hidráulica a pared con retención

€/u

Derecha **1487/D..**

Izquierda **1487/Z..**



Bisagra hidráulica PARED - VIDRIO

- Penture haute
- Top pivoting hinge
- Cerniera superiore pivotante



€/u

Derecha **1488/D..**

Izquierda **1488/Z..**



Bisagra hidráulica VIDRIO - VIDRIO

- Charnière hydraulique
- Hydraulic hinge
- Cerniera idraulica



al Aluminio

8-10 mm

25 kg/u

50.000 ciclos



*RIO HIDRÁULICA



BISAGRA PARED-VIDRIO HIDRÁULICA REGULABLE
CHARNIÈRE MUR-VERRE HYDRAULIQUE RÉGLABLE
WALL-GLASS HINGE ADJUSTABLE HYDRAULIC
CERNIERA MURO-RETRO IDRAULICA REGOLABILE

- *1485/022
- *1485/028
- *1485/00N

- Mides màxima de porta 850x2100mm
 - Pes màxim per porta 22.5Kg per us

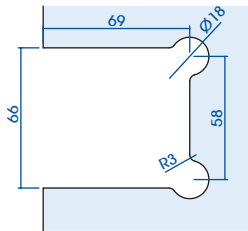

INOX BR	INOX SAT	ZINCADO
INOX POLI	INOX SAT	PL. ZINC
P.S.S.	S.S.S.	ZINC PL.
INOX LLC	INOX SAT	ZINCATO
22	28	34

INOX S.S.	Ciclos: 50.000	€/u
8-12 mm	22,5kg/u	Ancho max. 850mm



MALLORCA HIDRÁULICA



BISAGRA PARED-VIDRIO HIDRÁULICA CON LLAVE PARA REGULAR
CHARNIÈRE MUR-VERRE HYDRAULIQUE AVEC CLÉ POUR RÉGULER
WALL-GLASS HINGE HYDRAULIC WITH KEY FOR REGULATE IT
CERNIERA MURO-RETRO IDRAULICO CON CHIAVE PER REGOLARLO

4100/H22

INOX BR	INOX SAT
INOX POLI	INOX SAT
P.S.S.	S.S.S.
INOX LLC	INOX SAT
22	28

Cu	Ciclos: 100.000	€/u
8-12 mm	20 kg/u	Ancho max. 900mm
0°-90°-180°		Alto max. 2200mm

lx	Ciclos: 100.000	€/u
8-12 mm	20 kg/u	Ancho max. 900mm
		Alto max. 2200mm

BISAGRA VIDRIO-VIDRIO HIDRÁULICA CON LLAVE PARA REGULAR
CHARNIÈRE VERRE-VERRE HYDRAULIQUE AVEC CLÉ POUR RÉGULER
GLASS-GLASS HINGE HYDRAULIC WITH KEY FOR REGULATE IT
CERNIERA VETRO-VETRO IDRAULICO CON CHIAVE PER REGOLARLO

4101/H22

lx	Ciclos: 100.000	€/u
8-12 mm	20 kg/u	Ancho max. 900mm
		Alto max. 2200mm

BISAGRA PARED-VIDRIO DESPLAZADA HIDRÁULICA CON LLAVE PARA REGULAR
CHARNIÈRE MUR-VERRE DESPLACÉE HYDRAULIQUE AVEC CLÉ POUR RÉGULER
WALL-GLASS HINGE HYDRAULIC OFFSET WITH KEY FOR REGULATE IT
CERNIERA MURO-RETRO ALA SPOSTATA IDRAULICO CON CHIAVE PER REGOLARLO

4103/H22

*ATLANTA

BISAGRA PARED CON FRENO HIDRAULICO

charnière mur ferme-porte hydraulique réglable
wall hinge hydraulic spring floor adjustable
cerniera parete chiudiporta idraulico regolabile

Vidrio 8-10-12 mm
 Peso max. 80 kg/puerta
 ancho max. 100 cm
 Para uso interior
 Testada 500.000 ciclos



BISAGRA VIDRIO-VIDRIO HIDRÁULICA PARA INTERIORES
FERME-PORTE HYDRAULIQUE UTILISATION EN INTÉRIEUR
HYDRAULIC HINGE FOR INDOOR USE
CERNIERA IDRAULICA PER USO INTERNO

*1547/022

INOX S.S.	8-10-12 mm	€/u
0°-90°-180°	112 x 174 mm	

*0

ZURICH

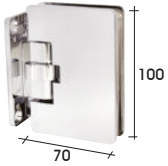

BISAGRA AUTOMÁTICA PARED-VIDRIO
CHARNIÈRE AUTOMATIQUE MUR-VERRE
AUTOMATIC HINGE WALL-GLASS
CERNIERA AUTOMATICA PARETE-VERRO
4135/Z32 zamak



BISAGRA AUTOMÁTICA VIDRIO-VIDRIO 180°
CHARNIÈRE AUTOMATIQUE VERRE-VERRE 180°
AUTOMATIC HINGE GLASS-GLASS 180°
CERNIERA AUTOMATICA VETRO-VETRO 180°
4136/Z32 zamak

CR. BRILLO CHR. POLI BR. CHR CR. LLUC.	INOX INOX POLI P.S.S. INOX LLUC.	BR INOX POLI P.S.S. INOX LLUC.	TITANIO TITANE TITANIUM TITANIO	INOX SAT INOX SAT S.S.S. INOX SAT
32	22	06	28	

Zn		70x100 mm	€/u
	8-12 mm	25 kg/u	0°-90°-180°

Zn		147x100 mm	€/u
	8-12 mm	25 kg/u	0°-90°-180°

LUGO



BISAGRA PARED-VIDRIO REGULABLE
CHARNIÈRE MUR-VERRE
ADJUSTABLE HINGE WALL-GLASS
CERNIERA PARETE-VERRO REGOLABILE
5310/R32 regulable



BISAGRA REGULABLE VID.-VID. 180°
CHARNIÈRE RÉGLABLE VER.-VER. 180°
ADJUSTABLE HINGE GLASS-GLASS 180°
CERNIERA REGOLABILE VET-VET. 180°
***5311/R32** regulable

CR. BRILLO CHR. POLI BR. CHR CR. LLUC.	CR. MATE CHR. M M. CHR CR. OPAC	PL. MATE ANOD. M AN. CAN ALL. NATUR	NEGRO NOIR BLACK NERO
32	31	01	0N

Cu		177x55 mm	€/u
	8-10 mm	22 kg/u	0°-90°-180°

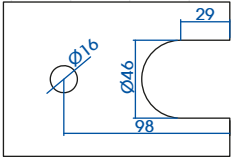

Cu		228x55 mm	€/u
	8-10 mm	22 kg/u	0°-90°-180°

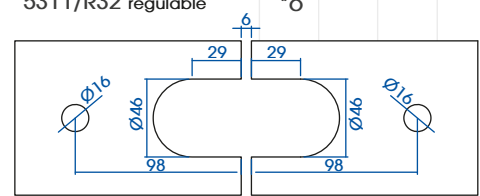

***SUIZA**

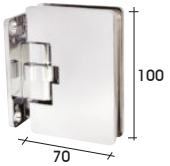

BISAGRA AUTOMÁTICA PARED-VIDRIO
CHARNIÈRE AUTOMATIQUE MUR-VERRE
AUTOMATIC HINGE WALL-GLASS
CERNIERA AUTOMATICA PARETE-VERRO
***4152/0..** latón



BISAGRA AUTOMÁTICA VIDRIO-VIDRIO 180°
CHARNIÈRE AUTOMATIQUE VERRE-VERRE 180°
AUTOMATIC HINGE GLASS-GLASS 180°
CERNIERA AUTOMATICA VETRO-VETRO 180°
***4153/0..** latón

Cu		70x100 mm	€/u
	8-12 mm	25 kg/u	0°-90°-180°

Cu		147x100 mm	€/u
	8-12 mm	25 kg/u	0°-90°-180°

***MENORCA**



BISAGRA PARED-VIDRIO REGULABLE
CHARNIÈRE MUR-VERRE
ADJUSTABLE HINGE WALL-GLASS
CERNIERA PARETE-VERRO REGOLABILE
***4187/R32** regulable



BISAGRA REGULABLE VID.-VID. 180°
CHARNIÈRE RÉGLABLE VER.-VER. 180°
ADJUSTABLE HINGE GLASS-GLASS 180°
CERNIERA REGOLABILE VET-VET. 180°
***4186/R32** regulable

Cu		112x55 mm	€/u
	8-10 mm	22 kg/u	0°-90°-180°

Cu		228x55 mm	€/u
	8-10 mm	22 kg/u	0°-90°-180°

***GAUDÍ**



BISAGRA AUTOMÁTICA PIVOTANTE
CHARNIÈRE AUTOMATIQUE PIVOTANT
PIVOTING AUTOMATIC HINGE
CERNIERA AUTOMATICA PIVOTANTE

JUEGOS DE 2 UNIDADES
JEUX DE 2 UNITÉS
SET 2 PIECES
SET 2 PEZZI
***1551/0.. sup.**
***1550/0.. inf.**

inox s.s.	Al	180x65	€/u
	10-12 mm	60 kg	0°-360°
<-> max. 900 mm			

			*o
			*o

HERRAJE FIJO 90° PARED-VIDRIO
FIXATION MUR-VERRE 90°
BRACKET WALL-GLASS 90°
MORSETTO PARETE-VERRO 90°

4108/022 inox
4108/Z32 zamak
4108/ZON zamak

	45x45 mm	€/u
	8-12 mm	∅ 16 mm

inox s.s.			
Zn			

HERRAJE FIJO 90° PARED-VIDRIO
FIXATION MUR-VERRE 90°
BRACKET WALL-GLASS 90°
MORSETTO PARETE-VERRO 90°
***4199/032**

Cu		51x51 mm	€/u
	8-10 mm	∅ 16 mm	

***VERNA**



BISAGRA VIDRIO-VIDRIO 180°
CHARNIÈRE VERRE-VERRE 180°
HINGE GLASS-GLASS 180°
CERNIERA VETRO-VETRO 180°
***4151/031** latón

CR. MATE CHR. M M. CHR CR. OPAC	31		
--	----	--	--

Cu		147x100 mm	€/u
	8-12 mm	25 kg/u	0°-90°-180°

FRENOS IMPORTACIÓN

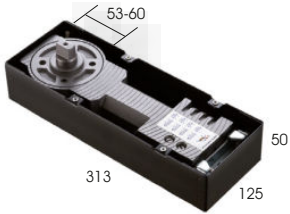

FRENO
FERME-PORTE
DOOR CLOSER
CHIUDIPIORTA

*1564/022

leva española
broches espagnol, Spanish pin, perno spagnolo

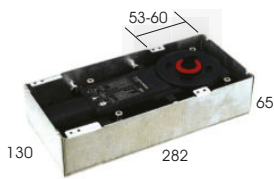

ANCHO MÁXIMO PUERTA: 1 m
largeur maximale porte
max. width door
larghezza massima porta

REGULACIÓN VEL. CIERRE: 0°-115°
régulation de la vitesse de fermeture
closing action program
programma velocità chiusura

TAPA INOX BRILLO INCLUIDA
couvercle en acier inoxydable
poli inclus
polish stainless steel cover included
copertina in acciaio inclusa

FRENO COMPATIBLE SPEEDY® M25
FERME-PORTE COMPATIBLE SPEEDY® M25
DOOR CLOSER COMPATIBLE SPEEDY® M25
CHIUDIPIORTA COMPATIBLE SPEEDY® M25

*1562/022 **leva española**
broches espagnol, Spanish pin, perno spagnolo

1563/022 leva italiana
broches italienne, Italian pin, perno italiano

INOX BR	INOX SAT	ZINCADO
INOX POLI	INOX SAT	PL. ZNK
P.S.S.	S.S.S.	ZNK PL.
INOX LUC.	INOX SAT	ZNCATO
22	28	34

inox s.s.	<-> max. 1200 mm	€/u
	90°-25° / 25°-0°	135kg/u
	stop 0°-90°-180°	

*o 14x8

inox s.s.	<-> max. 1000 mm	€/u
	115°-25° / 25°-0°	120kg/u
	stop 0°-90°-180°	

*o 14x8

o 16x16

PLINTO *

PLINTO COMPATIBLE CON SERIE "MARINA"
SUPPORT-RAIL PORTE COMPATIBLE AVEC LA SÉRIE "MARINA"
DOOR RAIL COMPATIBLE WITH "MARINA" SERIES
SUPPORTO-BINARIO COMPATIBILE CON SERIE "MARINA"

PLINTO SUPERIOR PARA GIRO SUPERIOR Ø 12 mm
PENTURE HAUTE POUR CRAPAUDINE HAUTE Ø 12 mm
TOP PIVOTING POLE FOR CEILING PIVOT Ø 12 mm
CERNIERA INFERIORE PIVOTANTE PER GIRO SUPERIORE Ø 12 mm
*1552/022



PLINTO INFERIOR LEVA ITALIANA
PENTURE BASSE BROCHES ITALIENNE
BOTTOM PIVOTING POLE ITALIAN PIN
CERNIERA INFERIORE PIVOTANTE PERNO ITALIANO
*1553/022



PLINTO INFERIOR LEVA ITALIANA Y CERRADURA
PENTURE BASSE BROCHES ITALIENNE ET SERRURE
BOTTOM PIVOTING POLE ITALIAN PIN WITH LOCK
CERNIERA INFERIORE PIVOTANTE PERNO ITALIANO CON SERRATURA
*1554/022



PERFIL PARA LATERAL FIJO
PROFIL DE CÔTÉ FIXE
FIXED GLASS PROFILE
PROFILO LATERALE FISSO
*1555/022



INOX BR	INOX SAT	ZINCADO
INOX POLI	INOX SAT	PL. ZNK
P.S.S.	S.S.S.	ZNK PL.
INOX LUC.	INOX SAT	ZNCATO
22	28	34

inox s.s.	Al		1200x68x33	€/u
			10-15mm	100 kg

*o Ø 12

16x16

*o

16x16

*o

inox s.s.	Al		1300x68x33	€/u
			10-15mm	

*o



GIRO INFERIOR LEVA ITALIANA
CRAPAUDINE BASSE BROCHES ITALIENNE
FLOOR PIVOT ITALIAN PIN
GIRO INFERIORE PERNO ITALIANO
4396/028



inox s.s.		16x16	€/u
-----------	--	-------	-----

o o

GIRO SUPERIOR Ø 12 mm
CRAPAUDINE HAUTE Ø 12 mm
CEILING PIVOT Ø 12 mm
GIRO SUPERIORE Ø 12 mm
1571/022



inox s.s.	Ø 12	€/u
-----------	------	-----

o

ACCESORIOS COMUNES



TOPE PUERTA VIDRIO FIJO
ARRETES DE PORTE VERRE FIXE
DOOR STOPPER FIXED GLASS
STOP PORTA A VETRO FISSO
***4388/028**



TOPE PUERTA A PARED Y TECHO
ARRETES DE PORTE MUR O PLAFOND
DOOR STOPPER WALL OR CEILING
STOP PORTA A TETTO O PARETE
4389/02.



TOPE PUERTA SUELO
ARRETES DE PORTE DU SOL
FLOOR DOOR STOPPER
STOP PORTA A PAVIMENTO
***1593/0..**



TOPE PUERTA SUELO
ARRETES DE PORTE DU SOL
FLOOR DOOR STOPPER
STOP PORTA A PAVIMENTO
1599/0..

MALAGA



GIRO SUPERIOR Ø 6 mm
CRAPAUDINE HAUTE Ø 6 mm
CEILING PIVOT Ø 6 mm
GIRO SUPERIORE Ø 6 mm
***5571/028**



GIRO SUPERIOR VIDRIO FIJO
SUPPORT HAUTE VERRE FIXE+PIVOT
FIXED GLASS UPPER SUPPORT+PIVOT
SUPPORTO A VETRO FISSO+GIRO SUP.
***5572/028**



GIRO SUPERIOR 2 VIDRIOS FIJOS
SUPPORT HAUTE 2 VERRES FIXES+PIVOT
2 FIXED GLASSES UPPER SUPPORT+PIVOT
SUPPORTO 2 VETRI FISSI+GIRO SUP.
***5576/028**

CR. BRILLO	CR. MATE	INOX BR	INOX SAT
CR. POLI	CR. M	INOX POLI	INOX SAT
BR. CHR	M. CHR	P.S.S.	S.S.S.
CR. LLC.	CR. OPAC	INOX LLC	INOX SAT
32	31	22	28
inox s.s.	10-12mm		€/u
	Ø 26 mm	∠ 32 mm	
			*o
inox s.s.			€/u
		o	o
inox s.s.			€/u
		*o	*o
inox s.s.			€/u
		o	o
inox s.s.	Ø 15		€/u
			*o
inox s.s.	10-12mm		€/u
			*o
inox s.s.	10 mm		€/u
			*o
inox s.s.			€/u
		o	o
inox s.s.	Ø 12		€/u
		o	

***MARINA**



GIRO SUPERIOR VIDRIO FIJO
SUPPORT HAUTE VERRE FIXE+PIVOT
FIXED GLASS UPPER SUPPORT+PIVOT
SUPPORTO A VETRO FISSO+GIRO SUP.
***1568/022**



HERRAJE SUPERIOR
PENTURE HAUTE
TOP PIVOTING HINGE
CERNIERA SUPERIORE PIVOTANTE
***1572/0..**

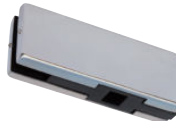

HERRAJE INFERIOR
PENTURE BASSE
BOTTOM PIVOT HINGE
CERNIERA INFERIORE PIVOTANTE
***1573/022 leva italiana**
broches italienne, Italian pin, perno italiano



GIRO SUPERIOR 2 VIDRIOS FIJOS
SUPPORT HAUTE 2 VERRES FIXES+PIVOT
2 FIXED GLASSES UPPER SUPPORT+PIVOT
SUPPORTO 2 VETRI FISSI+GIRO SUP.
***1575/022**



GIRO SUPERIOR PARED Y VIDRIO FIJO
SUPPORT HAUTE VERRE FIXE ET MUR
+PIVOT
FIXED GLASS AND WALL UPPER
SUPPORT+PIVOT
SUPPORTO A VETRO FISSO E
PARETE+GIRO SUP.
***1577/022**



GIRO SUPERIOR 2 VIDRIOS FIJOS
SUPPORT HAUTE 2 VERRES FIXES
2 FIXED GLASSES UPPER SUPPORT
SUPPORTO 2 VETRI FISSI
***1576/022**



CERRADURA ESQUINA INFERIOR
SERRURE COIN INFÉRIEUR
BOTTOM CORNER LOCK
SERRATURA ANGOLO INFERIORE
***1569/022**



GIRO INFERIOR LEVA ITALIANA
CRAPAUDINE BASSE BROCHES ITALIENNE
FLOOR PIVOT ITALIAN PIN
GIRO INFERIORE PERNO ITALIANO
4396/028



GIRO SUPERIOR Ø 12 mm
CRAPAUDINE HAUTE Ø 12 mm
CEILING PIVOT Ø 12 mm
GIRO SUPERIORE Ø 12 mm
1571/022

INOX BR	INOX SAT	ZINCADO
INOX POLI	INOX SAT	PL. ZNK
INOX LLC	INOX SAT	ZNK PL.
		ZINCATO
22	28	34
inox s.s.	Al	10-12mm
		€/u
		Ø 12 mm
		*o
inox s.s.	Al	10-12mm
		€/u
		Ø 12 mm
		*o
		*o
inox s.s.	Al	10-12mm
		€/u
		60 kg
		*o
		16x16
inox s.s.	Al	10-12mm
		€/u
		Ø 12 mm
		*o
inox s.s.	Al	10-12mm
		€/u
		*o
inox s.s.		10-12mm
		€/u
		*o
inox s.s.		16x16
		€/u
		o
		o
inox s.s.		Ø 12
		€/u
		o

LYON



BISAGRA PARED-VIDRIO
CHARNIÈRE MUR-VERRE
HINGE WALL-GLASS
CERNIERA PARETE-VERRO
4154/0..

ORMATE CHR. M MCHR OROPAC	CR. BILLO C-FR. POU BR. CHR CR. ILLC.	NEGRO NOR BLACK NERO
31	32	0N

Zn	35 kg/u	97x45 mm	€/u
8-10 mm	0°-90°	2Ø15mm	

BISAGRA LYON - NEGRO MATE
4154/00N

VIENA



BISAGRA PARED-VIDRIO
CHARNIÈRE MUR-VERRE
HINGE WALL-GLASS
CERNIERA PARETE-VERRO
*1478/0..

Al	25 kg/u	0°-90°	84x46	€/u
8-10 mm			2Ø12mm	

*0 *0

GALICIA



BISAGRA PARED-VIDRIO
CHARNIÈRE MUR-VERRE
HINGE WALL-GLASS
CERNIERA PARETE-VERRO
4194/001
4194/00N

Al	25 kg/u	0°-90°	100X50	€/u
8-10 mm			2Ø16mm	

PL.MATE ANOD.M AN.CAN. ALL.NATUR.	01
INOX SAT INOX SAT S.S.S. INOX SAT	28

BONN*



BISAGRA PARED-VIDRIO
CHARNIÈRE MUR-VERRE
HINGE WALL-GLASS
CERNIERA PARETE-VERRO
*4148/028 der.
droite/right/destra
*4149/028 izq.
gauche/left/sinistra

inox s.s.	30 kg/u	131x43 mm	€/u
		10-12 mm	0°-90°
		2 x Ø 16 mm	

*0 *0

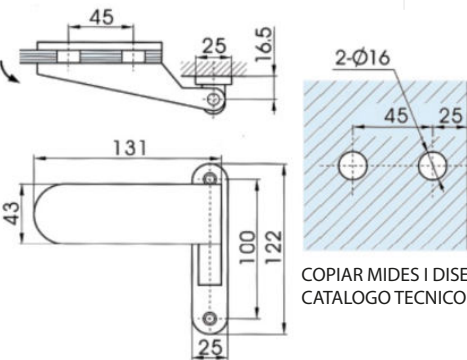

COPIAR MIDES I DISENY
CATALOGO TECNICO

DIVISORIAS

PERFILES PARA
PUERTAS
DIVISORIAS

PL.MATE ANOD.M AN.CAN. ALL.NATUR.	NEGRO NOR BLACK NERO	PLÁSTICO PLASTIC PLASTIC PLASTICA
01	0N	09



PERFILERÍA PARA DIVISORIAS
DE VIDRIO
PROFILS POUR CLOISONS EN VERRE
PROFILES FOR GLASS PARTITIONS
PROFILI PER PARTIZIONI IN VETRO
5580/30.

Al	3 m	10-12mm	€/m
----	-----	---------	-----

PERFIL BASTIDOR
PROFILS DE CADRES DE PORTE
DOOR FRAME PROFILES
PROFILI PER TELAI PORTE
5581/3..

Al	3 m		€/m
----	-----	--	-----

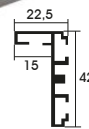

JUNTA MARCO PUERTA
JOINT DE CADRE DE PORTE
DOOR FRAME GASKET
GUARNIZIONE TELAIO PORTA
5582/109

PVC	Rolló 6 Metros	€/m
-----	----------------	-----

ESCUADRAS PARA
MARCO DE PUERTA
CARRÉS POUR CADRE DE PORTE
SQUARES FOR DOOR FRAME
SQUADRE PER TELAIO PORTA
5583/000

Al		€/u
----	--	-----

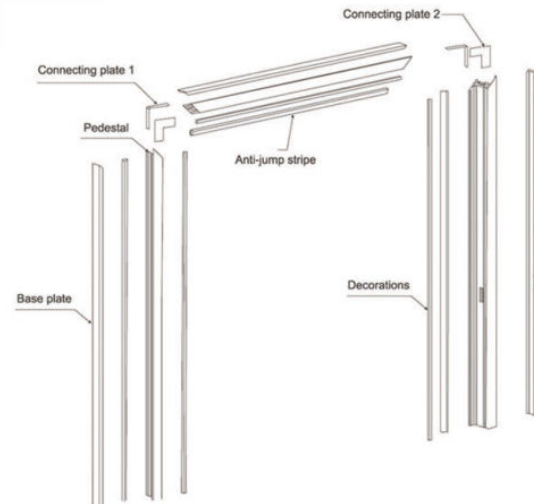

PERFILES

SELLADORES PUERTAS

PARA PUERTAS DE VIDRIO

NOVEDAD



PERFIL SELLADOR PARA PUERTA DE VIDRIO Y MADERA

profil d'étanchéité portes (verre et bois)
door sealing profile (glass and wood)
profilo di chiusura porta (vetro e legno)

5285/DO.
DERECHA
5285/ZO.
IZQUIERDA

5286/DO.
DERECHA
5286/ZO.
IZQUIERDA

CR. BILLO CHR. POLI BR. CHR CR. LUC.	INOX BR INOX POLI P.S.S. INOX LUC	PL.MATE ANOD.M AL.CAN. ALL.NATUR.	NEGRO NOR BLACK NERO
32	22	01	0N

€/u ADHESIVO

Ancho max.(cm)
88-100

€/u Ancho max.(cm)
72-82

HERRAJES FIJOS



HERRAJE FIJO 90° PARED-VIDRIO
FIXATION MUR-VERRE 90°
BRACKET WALL-GLASS 90°
MORSETTO PARETE-VERRO 90°

4095/032

Zn	45x45 mm	€/u
	6-12 mm	Ø 14 mm



HERRAJE FIJO 90° VIDRIO-VIDRIO
FIXATION VERRE-VERRE 90°
BRACKET GLASS-GLASS 90°
MORSETTO VETRO-VETRO 90°

4096/032

*4096/022

Cu inox s.s.	45x45 mm	€/u
	6-12 mm	2x Ø 14 mm



HERRAJE FIJO 180° VIDRIO-VIDRIO
FIXATION VERRE-VERRE 180°
BRACKET GLASS-GLASS 180°
MORSETTO VETRO-VETRO 180°

4097/032

Cu inox s.s.	90x45 mm	€/u
	6-12 mm	2x Ø 14 mm



HERRAJE FIJO 90° PARED-VIDRIO
FIXATION MUR-VERRE 90°
BRACKET WALL-GLASS 90°
MORSETTO PARETE-VERRO 90°

4108/022 inox

4108/Z32 zamak

4108/Z0N zamak negro

	45x45 mm	€/u
	8-12 mm	Ø 16 mm



MORSETTO VIDRIO-PARED
FIXATION VERRE-MUR
BRACKET GLASS-WALL
MORSETTO VETRO-PARETE

4105/032

Cu	60x50 mm	€/u
	8-12 mm	Ø 16 mm



HERRAJE FIJO 90° VIDRIO-VIDRIO
FIXATION VERRE-VERRE 90°
BRACKET GLASS-GLASS 90°
MORSETTO VETRO-VETRO 90°

4099/022

inox s.s.	90x45 mm	€/u
	8-12 mm	3x Ø 14 mm

"U" INOX

"U" INOX PULIDO
U INOX POLI
U POL. STAINLESS STEEL
U INOX LUCIDO

15x15x15x1 mm
4375/122

15x12x15x1 mm
4376/122

25x15x25x1 mm
4377/122

inox s.s.	3 mm	€/m
-----------	------	-----

max.12 mm

max. 8 mm

max.12 mm

CERRADURAS

SIN MUESCAS

CR. BILLO CHR. POLI BR. CHR CR. LUC.	PL.MATE ANOD.M AL.CAN. ALL.NATUR.	INOX BR INOX POLI P.S.S. INOX LUC	INOX SAT INOX S.S. INOX SAT
32	01	22	28



CERRADURA SIN MUESCA
SERRURE SANS ENCOCHE
LOCK WITHOUT CUT-OUT
SERRATURA SENZA TACCA
CUBILETE 1801 INCLUIDO
GÄUCHE 1801 INCLUS
STRIKE 1801 INCLUDED
CONTROSERRATURA 1801 INCLUSA

1800/0..10mm

1799/0..12mm

inox s.s.		70x63	€/u
	10-12 mm	∅ 1802	



CONTRACERRADURA VIDRIO SIN MUESCA
GÄUCHE VERRE SANS ENCOCHE
GLASS STRIKE WITHOUT CUT-OUT
CONTROSERRATURA VETRO SENZA TACCA

1802/0..10mm

1803/0..12mm

inox s.s.		70x63	€/u
	10-12 mm	∅ 1800-1799	



CERRADURA VIDRIO-PARED SIN MUESCA
SERRURE VERRE-MUR SANS ENCOCHE
GLASS-WALL LOCK WITHOUT CUT-OUT
SERRATURA VETRO-PARETE SENZA TACCA

4193/P22

inox s.s.		90x64	€/u
	10-12 mm		



CERRADURA VIDRIO-VIDRIO SIN MUESCA
SERRURE VERRE-VERRE SANS ENCOCHE
GLASS-GLASS LOCK WITHOUT CUT-OUT
SERRATURA VETRO-VETRO SENZA TACCA

4193/V22

inox s.s.		180x64	€/u
	10-12 mm		



CERRADURA VIDRIO-PARED SIN MUESCA
SERRURE VERRE-MUR SANS ENCOCHE
GLASS-WALL LOCK WITHOUT CUT-OUT
SERRATURA VETRO-PARETE SENZA TACCA

***4178/P22**

inox s.s.		90x64	€/u
	10-12 mm		

PESTILLO SIN MUESCA



PESTILLO SIN MUESCA
VERROU SANS ENCOCHE
BOLT WITHOUT CUT-OUT
CHIAVISTELLO SENZA TACCA

4175/032 Latón

Cu		60x50	€/u
	8-10 mm	∅ 4177	



CERRADURA SIN MUESCA CON LLAVE
SERRURE SANS ENCOCHE AVEC CLÉ
LOCK WITHOUT CUT-OUT WITH KEY
SERRATURA SENZA TACCA CON CHIAVE

4176/032 Zamak

Zn		60x50	€/u
	8-10 mm	∅ 4177	



CUBILETE
GÄUCHE
STRIKE PLATE
CONTROSERRATURA

4177/032

Cu		∅ 12	∅ 25 (10)	€/u
	∅ 4175-4176			



CONTRA PESTILLO VIDRIO SIN MUESCA
GÄUCHE VERRE SANS ENCOCHE
GLASS STRIKE PLATE WITHOUT CUT-OUT
CONTROSERRATURA VETRO SENZA TACCA

4158/032

Cu		30x45	€/u
	8-12 mm	∅ 4159	



PESTILLO SIN MUESCA
VERROU SANS ENCOCHE
BOLT WITHOUT CUT-OUT
CHIAVISTELLO SENZA TACCA

4159/032

Cu		30x45	€/u
	8-12 mm	∅ 4177-4158	



CUBILETE
GÄUCHE
STRIKE PLATE
CONTROSERRATURA

4177/032

Cu		∅ 12	∅ 25 (10)	€/u
	∅ 4159			

PREMIUM

NOVEDAD

SMART-LOCK

CERRADURAS INTELIGENTES



CERRADURA SMART-LOCK VIDRIO
serrure en verre smart-lock
smart-lock glass lock
serratura in vetro smart-lock
5540/00N €/u.



CERRADURA SMART-LOCK SLIM
serrure smart-lock Slim
"Slim" smart-lock
serratura smart-lock Slim
5553/00N €/u.



SMART LOCK CANTÓN - Cerradura DIGITAL CON TOUCH ID
smart lock - serrure électronique avec touch id
smart lock - digital lock with touch id
smart lock - serratura digitale con touch id
5541/00N €/u.

PARA PUERTA CON MARCO DE ALUMINIO

NEGRO
NOR
BLACK
NERO
ON

8-10 mm
Ø 60mm

8-10 mm
A Pared o a Vidrio

8-10 mm
A Pared o a Vidrio

MÚLTIPLES OPCIONES DE APERTURA

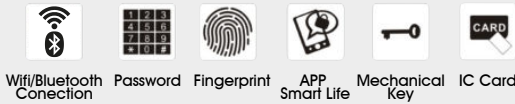

Cerraduras compatibles con sistema de domótica mediante APP Smart Life

Conexión WIFI a distancia mediante gateway "TUYA" / Consultar para más información.

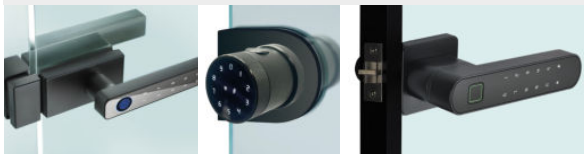

CERRADURAS MAGNÉTICAS

SLIM



SLIM - KIT CERRADURA MAGNÉTICA
Slim - serrure magnétique
Slim - magnetic lock
Slim - chiusura magnetica
5552/0.. €/u.

NÚRIA



NÚRIA - CERRADURA MAGNÉTICA
Núria - serrure magnétique
Núria - magnetic lock
Núria - chiusura magnetica
5550/0.. €/u.

CONTRACERRADURA MAGNÉTICA
contre-serrure magnétique
magnetic counterlock
controserratura magnetica
5551/0.. €/u.

NEGRO
NOR
BLACK
NERO
ON

8-10 mm
A Pared o a Vidrio

8-10 mm
120 mm

8-10 mm
5550

CERRADURAS

PARA CORREDERAS



BOMBÍN EUROPEO



CERRADURA PUERTA CORREDERA VIDRIO-PARED
SERRURE PORTES COULISSANTS
VERRE-MUR
SLIDING DOORS LOCK
GLASS-WALL
SERRATURE PORTE
SCORREVOLI VETRO-PARETE

LLAVE-PESTILLO
serrure-verrou
key bolt
chiave-pomolo

SIMÉTRICA
SYMMÉTRIQUE
SYMMETRIC
SIMMETRICA

4224/0..

CERRADURA PUERTA CORREDERA VIDRIO-VIDRIO
SERRURE PORTES COULISSANTS
VERRE-VERRE
SLIDING DOORS LOCK
GLASS-GLASS
SERRATURE PORTE
SCORREVOLI VETRO-VETRO

LLAVE-PESTILLO
serrure-verrou
key bolt
chiave-pomolo

SIMÉTRICA
SYMMÉTRIQUE
SYMMETRIC
SIMMETRICA

4225/0..

BOMBIN LLAVE AMBOS LADOS
4224/012

PL. M ALU. M ALU. M ALL. NAT	INOX INOX INOX	BR POL LUC	C-SAT. N SAT. N. C SAT. N. C C-SAT. N
01	22	38	

Al	8-12 mm	€/u
----	---------	-----

Al	8-12 mm	€/u
----	---------	-----

CIERRE PARA LAVABOS CON MANILLA



CERRADURA WC PESTILLO + INDICADOR
SERRURE WC
LOCK FOR WC
SERRATURA WC
***4134/022**



CONTRACERRADURA VIDRIO
GAÛCHE VERRE
GLASS STRIKE PLATE
CONTROSERRATURA VETRO
***4134/V22**



CONTRACERRADURA PARED
GAÛCHE MUR
WALL STRIKE PLATE
CONTROSERRATURA PARETE
***4134/P22**

MONTSE



CERRADURA CON MANEJA
SERRURE AVEC POIGNÉE
DOOR LOCK WITH HANDLE
SERRATURA CON MANIGLIA
5577/001
5577/00N

Al	inox s.s.	8-12mm	€/u
		Ø 2x42 mm	

Al	8-12 mm	€/u
	Ø 2x12 mm	

inox s.s.	∞ 4134	€/u
-----------	--------	-----

Al	8-10 mm	€/u
----	---------	-----

NEGRO
NOR
BLACK
NERO
ON

MÓNICA



CON LLAVE.
AVEC CLÉ, WITH KEY, CON CHIAVE



CON LLAVE.
AVEC CLÉ, WITH KEY, CON CHIAVE
PORTA BATTENTE.
PORTE BATTANTE, SWINGING DOOR,
PORTA BATTENTE



SIN LLAVE
SANSCLÉ, WITHOUT KEY, SENZA CHIAVE



SONIA



NEGRO NOIR BLACK NERO	INOX SAT INOX SAT S.S.S.	INOX BR INOX POLI P.S.S. INOX LUC	inox s.s.	Zn	Fe	8-10 mm	€/u
ON	28	22	inox s.s.			8-10 mm	€/u
CERRADURA CON MANETA Y CONTRACERRADURA SERRURE AVEC POIGNÉE ET GÂUCHE DOOR LOCK WITH HANDLE AND STRIKE PLATE SERRATURA CON MANIGLIA E CONTOSERRATURA							
			o		o		o
BOMBIN CON PESTILLO 4173/012							
							o
CERRADURA CON MANETA Y CONTRACERRADURA SERRURE AVEC POIGNÉE ET GÂUCHE DOOR LOCK WITH HANDLE AND STRIKE PLATE SERRATURA CON MANIGLIA E CONTOSERRATURA							
			o		o		o
4179/0.. 4179/031							
			o				
CERRADURA CON MANETA Y CONTRACERRADURA SERRURE AVEC POIGNÉE ET GÂUCHE DOOR LOCK WITH HANDLE AND STRIKE PLATE SERRATURA CON MANIGLIA E CONTOSERRATURA							
					o		o
4145/0..							
CONTRACERRADURA VIDRIO GÂUCHE VERRE GLASS STRIKE PLATE CONTOSERRATURA VETRO							
			*o		*o		*o
*4174/0..							
CONTRACERRADURA PARED O 4174 BATTENTE GÂUCHE BATTANT MUR OU 4174 WALL OR 4174 WING STRIKE PLATE CONTOSERRATURA BATTENTE PARETE O 4174							
							*o
*4157/012							
Al			Al			8-10mm	€/u
CERRADURA CON MANETA Y CONTRACERRADURA PARED SERRURE AVEC POIGNÉE ET GÂUCHE MUR DOOR LOCK WITH HANDLE AND STRIKE PLATE SERRATURA CON MANIGLIA E CONTOSERRATURA MURO							
							o
5569/022							
CONTRACERRADURA VIDRIO GÂUCHE VERRE GLASS STRIKE CONTOSERRATURA VETRO							
						8-10mm	€/u
							o
5570/022							

***MARTA**

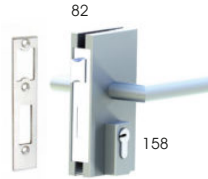

82

158



4256

4257

4258

GR.BILO GR.FOU BR.GR GR.LUC.	FL.MATÉ ANOD.M ALCAN. ALL.NATUR.	INOX BR INOX POLI P.S.S. INOX LUC	INOX SAT INOX SAT S.S.S. INOX SAT	inox s.s.	8-10 mm	€/u
32	01	22	28	inox s.s.	8-10 mm	€/u
CERRADURA CON MANETA Y CONTRACERRADURA PARED SERRURE AVEC POIGNÉE ET GÂUCHE MUR DOOR LOCK WITH HANDLE AND STRIKE PLATE SERRATURA CON MANIGLIA E CONTOSERRATURA MURO						
						*o
*4228/022						
BOMBIN CON PESTILLO *4228/012						
						*o
CERRADURA CON MANETA Y CONTRACERRADURA VIDRIO SERRURE AVEC POIGNÉE ET GÂUCHE VERRE DOOR LOCK WITH HANDLE AND GLASS STRIKE SERRATURA CON MANIGLIA E CONTOSERRATURA VETRO						
				inox s.s.	8-10 mm	€/u
						*o
*4229/022						
CONTRACERRADURA PARED/BATTENTE GÂUCHE BATTANT MUR WALL WING STRIKE PLATE CONTOSERRATURA BATTENTE PARETE						
				inox s.s.	4256	€/u
						*o
*4257/022 izq. *4258/022 der.						
						*o
CONTRACERRADURA VIDRIO GÂUCHE VERRE GLASS STRIKE CONTOSERRATURA VETRO						
				inox s.s.	4257-4258	€/u
						*o
*4256/022 der.						
						*o
KITS						
1478	4228	1478	4154	4179	4154	4194
KIT PUERTA BATTENTE KIT PORTE BATTANTE KIT SWINGING DOOR KIT PORTA BATTENTE						
						o
1478/032 2 u. 4228/022 1 u. 4249/032						
KIT PUERTA BATTENTE KIT PORTE BATTANTE KIT SWINGING DOOR KIT PORTA BATTENTE						
						o
4154 2 u. 4179 1 u. 4399/032 4399/031 4399/00N						
KIT PUERTA BATTENTE KIT PORTE BATTANTE KIT SWINGING DOOR KIT PORTA BATTENTE						
						o
4194 2 u. 5577 1 u. 4289/001 4289/00N						
						o

TIRADORES

(MANILLAS)

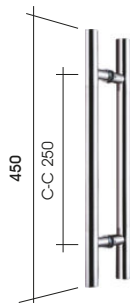

MANILLA DOBLE 45 CM
POIGNEÉ DOUBLE 45 CM
DOUBLE DOOR HANDLE 45 CM
MANIGLIA DOPPIA 45 CM
1590/0..

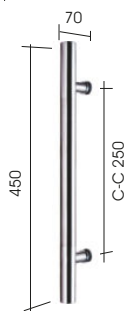

MANILLA SENCILLA 45 CM
POIGNEÉ 45 CM
SINGLE HANDLE 45 CM
MANIGLIONE SEMPLICE 45 CM
1594/022

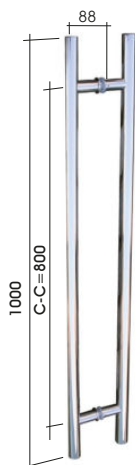

MANILLA DOBLE 100 CM
POIGNEÉ DOUBLE 100 CM
DOUBLE DOOR HANDLE 100 CM
MANIGLIA DOPPIA 100 CM
1592/0..

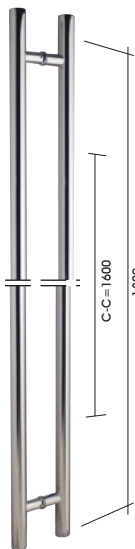

MANILLA DOBLE 180 CM
POIGNEÉ DOUBLE 180 CM
DOUBLE DOOR HANDLE 180 CM
MANIGLIA DOPPIA 180 CM
1591/02.

INOX BR	INOX SAT	NEGRO
INOX POLI	INOX SAT	NOIR
P.S.S.	S.S.S.	BLACK
INOX LUC	INOX SAT	NERO

22	28	ON
----	----	----

inox s.s.	8-12 mm	Ø 25	€/u
	2xØ12 mm	CC=250 mm	

○	○	○
---	---	---

inox s.s.	8-12 mm	Ø 25	€/u
	2xØ12 mm	CC=250 mm	

○

inox s.s.	8-12 mm	Ø 25	€/u
	2xØ12 mm	CC=800 mm	

○	○
---	---

inox s.s.	8-12 mm	Ø 38	€/u
	2xØ12 mm	CC=1600 mm	

○	○
---	---

TIRADORES

CON CERRADURA

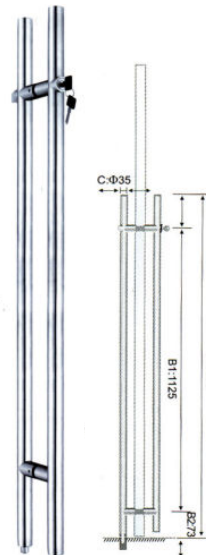

MANILLA DOBLE 150 CM
+ CERRADURA Y PESTILLO
POIGNEÉ DOUBLE 150 CM
+ SERRURE AND VERROU
DOUBLE HANDLE 150 CM
+ LOCK AND BOLT
MANIGLIONE DOPPIO 150 CM
+ SERRATURA E CHIAVISTELLO
1598/0..

INOX BR	INOX SAT
INOX POLI	INOX SAT
P.S.S.	S.S.S.
INOX LUC	INOX SAT

22	28
----	----

inox s.s.	10-12 mm	Ø 35	€/u
	1 x Ø mm	1 x Ø mm	

○	○
---	---

TUBO 20X20

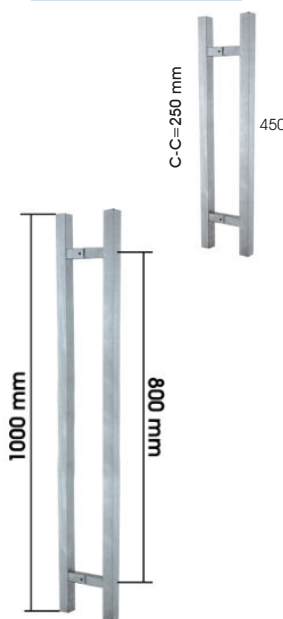

MANILLA DOBLE 45 CM
POIGNEÉ DOUBLE 45 CM
DOUBLE DOOR HANDLE 45 CM
MANIGLIA DOPPIA 45 CM
1597/0..

inox s.s.	8-12 mm	20x20	€/u
	2xØ12 mm	CC=250 mm	

○	○
---	---

€/u	6-8 mm	2 x Ø8mm
	100 cm	20x20 mm

TIRADOR 100 CM
ance mur-verre
wall-glass anchor
ancoraggio a parete in vetro
1585/0..

○	○
---	---

TUBO 50X25

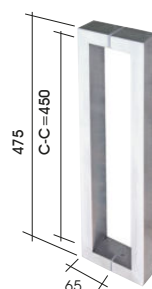

MANILLA DOBLE 47,5 CM
POIGNEÉ DOUBLE 47,5 CM
DOUBLE DOOR HANDLE 47,5 CM
MANIGLIA DOPPIA 47,5 CM
1596/028

inox s.s.	8-12 mm	50x25	€/u
	2xØ12 mm	CC=450 mm	

○

TIRADORES

(MANILLAS)



d. 48

TIRADOR DOBLE
BOUTON DOUBLE
DOUBLE KNOB
POMOLO DOPPIO
***1584/0..**



d. 35

TIRADOR DOBLE
BOUTON DOUBLE
DOUBLE KNOB
POMOLO DOPPIO
***4119/0..**

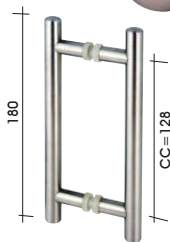

MANILLA DOBLE
POIGNEE DOUBLE
DOUBLE DOOR PULL
MANIGLIA DOPPIA
4127/0..

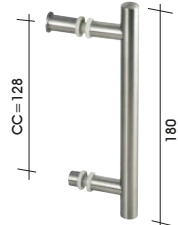

MANILLA + POMO
POIGNEE + BOUTON
DOOR PULL + KNOB
MANIGLIA + POMOLO
***4128/0..**



MANILLA DOBLE
POIGNEE DOUBLE
DOUBLE DOOR PULL
MANIGLIA DOPPIA
4139/Z32
4139/Z0N negro

MANILLA ALUMINIO

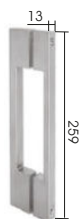

MANILLA DOBLE
POIGNEE DOUBLE
DOUBLE DOOR PULL
MANIGLIA DOPPIA
4129/A32
4129/A0N negro

TUBO Ø25



MANILLA DOBLE
POIGNEE DOUBLE
DOUBLE DOOR PULL
MANIGLIA DOPPIA
4126/022

CR. BRILLO	CR. MATE	TITANIO	INOX BR	INOX SAT
CR. POLI	CR. M	TITANIO	INOX POLI	INOX SAT
BR. CHR	M. CHR	TITANIO	P. S. S.	S. S. S.
CR. LUC.	CR. OPAC	TITANIO	INOX LUC	INOX SAT
32	31	06	22	28

Al	6-12 mm	Ø48x43	Ø 10 mm	€/u
----	---------	--------	---------	-----

Al	6-10 mm	Ø45x28	Ø 12 mm	€/u
----	---------	--------	---------	-----

inox s.s.	6-10 mm	Ø14		€/u
	2 x Ø 10 mm		CC=128 mm	

inox s.s.	6-10 mm	Ø14		€/u
	2 x Ø 10 mm		CC=128 mm	

Zn	6-10 mm	226x34		€/u
	2 x Ø 6 mm		CC=192 mm	

		NEGRO		
		NOR		
		BLACK		
		NERO		
		ON		

Al	6-10 mm	259x13		€/u
	2 x Ø 6 mm		CC=220 mm	

inox s.s.	6-12 mm	Ø25	€/u
	2xØ10 mm		CC=250 mm

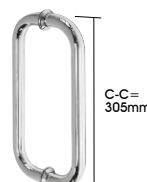

C-C=305mm

MANILLA DOBLE
POIGNEE DOUBLE
DOUBLE DOOR PULL
MANIGLIA DOPPIA
***4125/032**

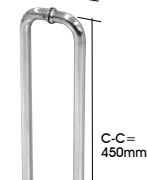

C-C=450mm

MANILLA DOBLE
POIGNEE DOUBLE
DOUBLE DOOR PULL
MANIGLIA DOPPIA
***4126/0E2**

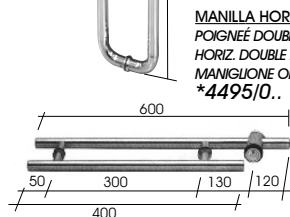

MANILLA HORIZONTAL + CERRADURA Y PESTILLO
POIGNEE DOUBLE HORIZ. + SERRURE AND VERROU
HORIZ. DOUBLE HANDLE + LOCK AND BOLT
MANIGLIONE ORIZZ. + SERRATURA E CHIAVISTELLO
***4495/0..**

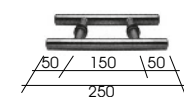

MANILLA HORIZONTAL + CONTRACERRADURA
POIGNEE DOUBLE HORIZ. + GAUCHE
HORIZ. DOUBLE HANDLE + STRIKE PLATE
MANIGLIONE ORIZZ. + CONTRASERR.
***4496/022**

UÑEROS

DE ALUMINIO ADHESIVO 3M



UÑERO DOBLE ADHESIVO
POIGNEE DOUBLE ADHESIVE
DOUBLE ADHESIVE PULL
POMO DOPPIO ADHESIVO
4207/0..

INOX 304 ADHESIVO 3M



UÑERO DOBLE ADHESIVO
POIGNEE DOUBLE ADHESIVE
DOUBLE ADHESIVE PULL
POMO DOPPIO ADHESIVO
4207/0..



GALGA MONTAJE UÑEROS
GABARIT DE MONTAGE
INSTALLATION TOOL
SAGOMA AIUTO MONTAGGIO
4209/000

DE ALUMINIO SIN MUESCA



POMO
POIGNEE
KNOB
POMO
4223/0..

INOX 304 CON TALADRO



UÑERO
POIGNEE
KNOB
POMO
4322/028



UÑERO
POIGNEE
KNOB
POMO
4337/0..

P. MATE	CR. BRILLO	INOX BR	INOX SAT
AV. D.M	CR. POLI	INOX POLI	INOX SAT
AV. CHR	BR. CHR	P. S. S.	S. S. S.
AV. OPAC	BR. LUC.	INOX LUC	INOX SAT
01	32	22	28

Cu	6-12 mm	Ø25	€/u
	2xØ10 mm		CC=305 mm

inox s.s.	6-12 mm	Ø19	€/u
	2xØ10 mm		CC=450 mm

inox s.s.	Ø 25		
	10-12 mm	€/u	
	2xØ14 mm		1xØ36 mm

inox s.s.	10-12 mm		
	2xØ14 mm		CC=150 mm
			Ø 25

inox s.s.	Ø 60	€/u
-----------	------	-----

Al	Ø 60	€/u
----	------	-----

		NEGRO	
		NOR	
		BLACK	
		NERO	
		ON	

Al		€/u
----	--	-----

		CR. BRILLO	
		CR. POLI	
		BR. CHR	
		CR. LUC.	
		32	

Al	100	8-10 mm	€/u
----	-----	---------	-----

inox s.s.	8-12 mm	€/u
	Ø 50 mm	

inox s.s.	8-12 mm	Ø 46 mm	€/u
-----------	---------	---------	-----

		NEGRO	
		NOR	
		BLACK	
		NERO	
		ON	



cotek.

BARANDILLAS

HERRAJES BARANDILLAS

GAMA PREMIUM

HERRAJES ALTA GAMA -
SOPORTE CON LUZ LED
COMPONENTES
MONTAJE

HERRAJES ALTA GAMA -
DISTANCIADOR DUPLEX

HERRAJES ALTA GAMA -
SOPORTES BARANDILLA DUPLEX
CON TILT-LOCK
5942
5941
1437

HERRAJES PARA PISCINA
BALLADOS COMPLETOS

SOPORTES BARANDILLA SUELO

REFUERZO PARA BARANDILLAS

UTILAJES ALINEACIÓN DEL VIDRIO

PINZAS PARA BARANDILLAS

DISTANCIADORES

DISTANCIADORES PARA
ESCALERAS VIDRIO

SOPORTES VIDRIO

PERFILES PASAMANOS

DELPHOS

MARQUESINAS

MINI CRUCETAS

VENTOSAS

ACCESORIOS VIDRIO
HERRAMIENTAS DE CORTE
BROCAS DIAMANTADAS
DISCOS Y BANDAS

SOPORTE CON LUZ LED

SOPORTE DE BARANDILLAS INOX DUPLEX - CON LUZ LED RGB OPCIONAL

Apto para ballado de piscinas

€/u **5975/022**

22



ix Inox 2205
DUPLEX

10-14,28
mm

SIN
AGUJEROS
EN EL VIDRIO



€/u **5976/000**

00



KIT LUZ

KIT D'ÉCLAIRAGE /
LIGHT KIT / KIT LUCE

Transformador
(de 240v a 12v)



Control remoto de color RGB

(Se recomienda instalar el lado
elevado del inductor hacia
arriba y no bloquear la
señal de inducción
con objetos extraños.)

**24m de
cable con
empalmes "T"**
(Distancia
entre "T" - 1,5m)



16 cables de luz RGB
(cables de 100 mm)



**16 cables
de extensión**
(250/455mm opcional)

**Mando
a distancia**



- Diseñado para encajar directamente el LED en el herraje.
- Ajustable: en velocidad, brillo de la luz y el color RGB (16 colores).
- Vida: 20.000 horas

- Grado de impermeabilidad: IP67
- Tamaño de la luz: 16,5*26mm

* Se recomienda vidrio templado y laminado acorde a la normativa vigente.

- SOPORTE NIVELABLE
- DISEÑO PARA INSERTAR DIRECTAMENTE EL LED

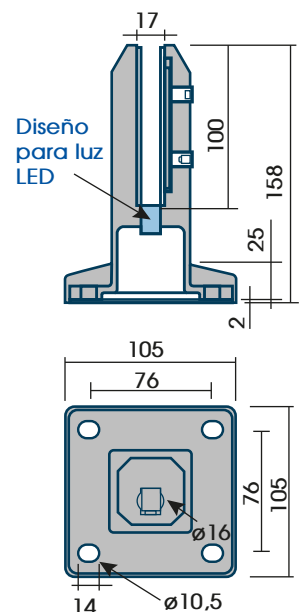



MONTAJE

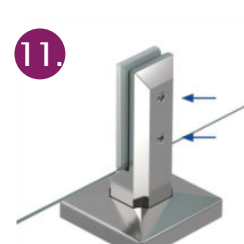
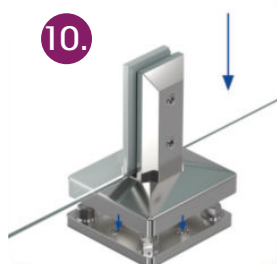
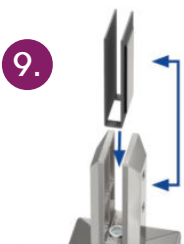
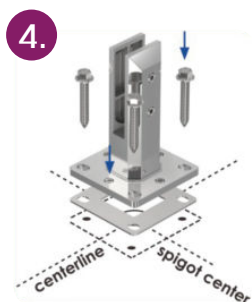
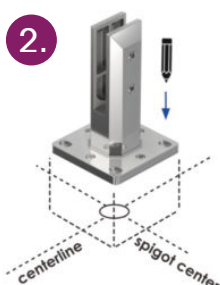

DISTANCIADOR INOX DUPLEX

DE REGULACIÓN CENTRAL

Anclaje
pared-vidrio

- Ancre mur-verre
- Wall-glass anchor
- Ancoraggio muro-vetro

5948/022

Llave de
regulación 5948

- Clé de régulation
- Regulation key
- Chiave di regolazione

5948/012

22



ix Inox 2205 DUPLEX

10-22 mm

Ø 38 mm

Ø24mm

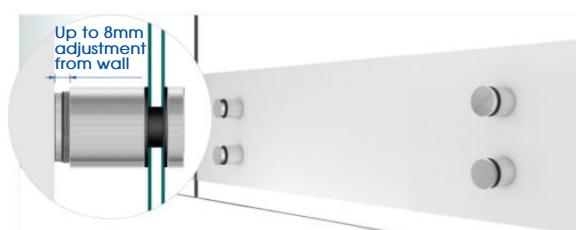
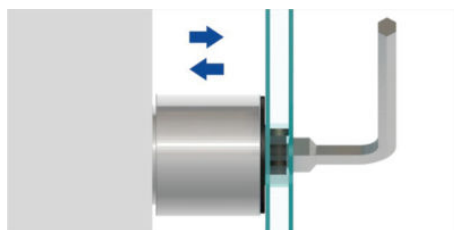

INSTRUCCIONES DE MONTAJE 5948

- 1.- Atornillar el elemento **A** a la pared con la tornillería mas adecuada según el tipo de pared.
- 2.- Enroscar la pieza **B** en la pieza **A** hasta el fondo.
- 3.- Enroscar el elemento **C** en el elemento **A**.
- 4.- Colocar el elemento **D** y colocar el cristal. Ajustar la posición de la fijación del elemento **A** (por la apertura que queda se puede acceder al tornillo de fijación de pared); Una vez ajustados los elementos **A** y **C** según necesidades, fijar con la llave **G2** el elemento **B** (desenroscar hasta que haga tope con el elemento **B**).
- 5.- Fijar con la llave **G1** el elemento **C**.
- 6.- Colocar el elemento **E**.
- 7.- Colocar el elemento **F** y fijar con la llave correspondiente.

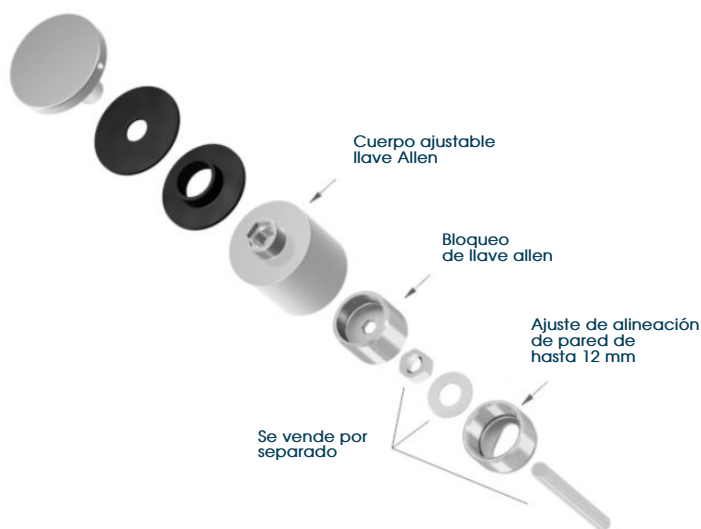
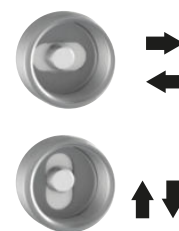
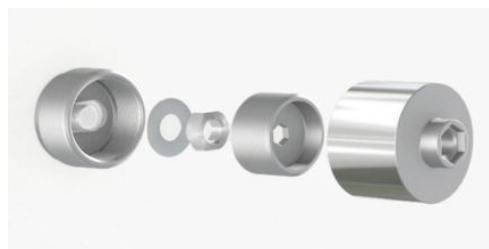

* Se recomienda vidrio templado y laminado acorde a la normativa vigente.

SOPORTES DE BARANDILLA DUPLEX

SOPORTES INOX 2205 DUPLEX CON TILT-LOCK



310

€/U

5942/0..

22 28 0N

○ ○ ○

Anclaje pared-vidrio

- Ancre mur-verre
- Wall-glass anchor
- Ancoraggio muro-vetro

ix Inox 2205 DUPLEX

12-17,5 mm

CON TILT-LOCK

~~SIN TALADROS EN EL VIDRIO~~



152

€/U

5941/0..

22 28 0N

○ ○ ○

Anclaje suelo-vidrio

- Ancre sol-verre
- Floor-glass anchor
- Ancoraggio pavimento-vetro

ix Inox 2205 DUPLEX

12-17,5 mm

CON TILT-LOCK

~~SIN TALADROS EN EL VIDRIO~~



150

€/U

1437/0..

22 28 0N

○ ○ ○

Anclaje pared-vidrio

- Ancre mur-verre
- Wall-glass anchor
- Ancoraggio muro-vetro

ix Inox 2205 DUPLEX

12-17,5 mm

CON TILT-LOCK

~~SIN TALADROS EN EL VIDRIO~~

* Se recomienda vidrio templado y laminado acorde a la normativa vigente.

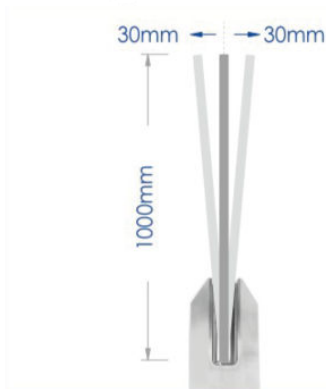

TILT-LOCK

Significa "inclinado y bloquear" un proceso simple que le permite simplemente inclinar el vidrio en los soportes para la alineación correcta y bloquear los tornillos sin cabeza.

HERRAJES PARA PISCINA

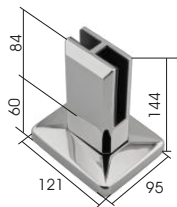

SOPORTE VIDRIO 180° INTERMEDIO
support de verre intermédiaire 180°
180° intermediate glass support
supporto vetro intermedio a 180°

Inx **5990/0..** €/u.

INOX duplex 2205

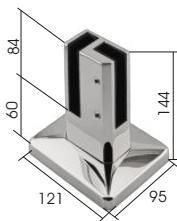

SOPORTE VIDRIO 90° ESQUINERO
support de verre d'angle 90°
90° corner glass support
supporto vetro angolare a 90°

Inx **5991/0..** €/u.

INOX duplex 2205

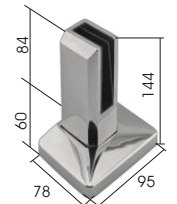

SOPORTE VIDRIO 90° ESQUINERO
support de verre d'angle 90°
90° corner glass support
supporto vetro angolare a 90°

Inx **5992/D..** €/u.

DERECHA

Inx **5992/Z..** €/u.

IZQUIERDA
INOX duplex 2205

NEGRO NOR BLACK NERO	INOX INOX P.S. INOX
ON	22



6+6 mm Inx DUPLEx 2205



6+6 mm Inx DUPLEx 2205



6+6 mm Inx DUPLEx 2205

HERRAJES PARA BALLADOS COMPLETOS



CERRADURA MAGNÉTICA DE SEGURIDAD INOX 316
serrure en acier inoxydable 316
316 stainless steel lock
serratura in acciaio inossidabile 316

Inx **5993/0..** €/u.



BISAGRA AUTOMÁTICA 180° INOX 316
charnière 180° en acier inoxydable 316
180° 316 stainless steel hinge
cerniera 180° in acciaio inossidabile 316

Inx **5994/0..** €/u. SET 2 BISAGRAS



BISAGRA AUTOMÁTICA VIDRIO-VIDRIO 180°
CHARNIÈRE AUTOMATIQUE
VERRE-VERRE 180°
AUTOMATIC HINGE GLASS-GLASS 180°
CERNIERA AUTOMÁTICA
VETRO-VETRO 180°

INOX 316
*1448/022 €/u. SET 2 BISAGRAS



SOPORTE BARANDILLA 90° VID-VID
Support de garde-corps verre-verre 90°
90° glass-glass railing support
Supporto ringhiera vetro-vetro 90°

Inx **5987/0..** €/u.

INOX duplex 2205



SOPORTE BARANDILLA VID-PARED
Support de garde-corps mur-verre
wall-glass railing support
Supporto ringhiera parete-vetro

Inx **5986/0..** €/u.

INOX duplex 2205



SOPORTE BARANDILLA 180° VID-VID
Support de garde-corps verre-verre 180°
180° glass-glass railing support
Supporto ringhiera vetro-vetro 180°

Inx **5985/0..** €/u.

INOX duplex 2205



SOPORTE REGULABLE EN ANGULO
support à angle réglable
angle adjustable support
supporto regolabile in angolazione

Inx **5984/0..** €/u.

INOX duplex 2205

NEGRO NOR BLACK NERO	INOX INOX P.S. INOX
ON	22



6+6 mm Inx 316

SEGURO PARA NIÑOS



6+6 mm Inx 316 18 KG/u

0°-90°-180°

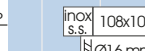

inox s.s. 108x100

Ø16 mm

12 mm €/u

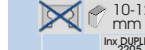

10-12 mm Inx DUPLEx 2205



10-12 mm Inx DUPLEx 2205



10-12 mm Inx DUPLEx 2205



10-12 mm Inx DUPLEx 2205



**SOPORTES
BARANDILLA SUELO**

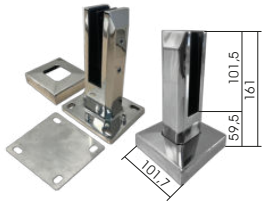

SOPORTE DE SUELO REGULABLE
support de sol réglable
adjustable floor stand
supporto da pavimento regolabile
Inx 1431/0..
INOX duplex 2205

NEGRO NOR BLACK NERO	INOX P.S.S. INOX	BR POLI LUC	INOX S.S.S. INOX	SAT SAT SAT
0N	22	28		

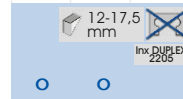

SOPORTE BARANDILLA
SUPPORT GARDE-CORPS
SUPPORT BALUSTRADE
SUPPORTO BALAUSTRRA
5975/022
INOX duplex 2205

inox s.s.	10-14,28 mm	€/u
SIN TALADROS EN EL VIDRIO		

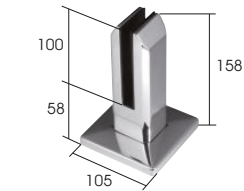

SOPORTE BARANDILLA
SUPPORT GARDE-CORPS
SUPPORT BALUSTRADE
SUPPORTO BALAUSTRRA
*1434/022 12 mm
INOX duplex 2205

inox s.s.	12 mm	€/u
SIN TALADROS EN EL VIDRIO		



SOPORTE BARANDILLA
SUPPORT GARDE-CORPS
SUPPORT BALUSTRADE
SUPPORTO BALAUSTRRA
1436/0.. 10-22 mm
INOX duplex 2205

inox s.s.	10-22 mm	€/u
SIN TALADROS EN EL VIDRIO		

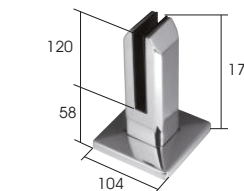

SOPORTE DE BARANDILLA
SUPPORT DE GARDE-CORPS
RAILING BRACKET
STAFFA PER RINGHIERA
1435/0..
INOX duplex 2205

inox s.s.	12-16 mm	€/u
SIN TALADROS EN EL VIDRIO		

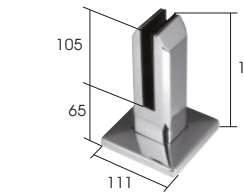

SOPORTE BARANDILLA
SUPPORT GARDE-CORPS
SUPPORT BALUSTRADE
SUPPORTO BALAUSTRRA
1438/0.. 12-16 mm
INOX 316

inox s.s.	12-16 mm	€/u
SIN TALADROS EN EL VIDRIO		



SOPORTE BARANDILLA
SUPPORT GARDE-CORPS
SUPPORT BALUSTRADE
SUPPORTO BALAUSTRRA
INOX duplex 2205
5943/022 12-21,5 mm

inox s.s.	12-21,5 mm	€/u
SIN TALADROS EN EL VIDRIO		



SOPORTE BARANDILLA
SUPPORT GARDE-CORPS
SUPPORT BALUSTRADE
SUPPORTO BALAUSTRRA
INOX 316
*1447/022 16 mm

inox s.s.	Ø 48 mm	€/u
inox s.s.	16 mm	€/u

**REFUERZO PARA
BARANDILLAS**



SOPORTE BARANDILLA
SUPPORT GARDE-CORPS
SUPPORT BALUSTRADE
SUPPORTO BALAUSTRRA
INOX duplex 2205
5944/0..

inox s.s.	16,7-19mm	€/u
SIN TALADROS EN EL VIDRIO		

16,7-19 mm -> Substitución progresiva a: 16,7-21,52
consultar*



SOPORTE BARANDILLA
SUPPORT GARDE-CORPS
SUPPORT BALUSTRADE
SUPPORTO BALAUSTRRA
INOX duplex 2205
5945/0.. 16,7-19 mm

inox s.s.	16,7-19mm	€/u
SIN TALADROS EN EL VIDRIO		

16,7-19 mm -> Substitución progresiva a: 16,7-21,52
consultar*



SOPORTE BARANDILLA
SUPPORT GARDE-CORPS
SUPPORT BALUSTRADE
SUPPORTO BALAUSTRRA
INOX duplex 2205
5946/0.. 16,7-19 mm

inox s.s.	16,7-19mm	€/u
SIN TALADROS EN EL VIDRIO		

16,7-19 mm -> Substitución progresiva a: 16,7-21,52
consultar*



SOPORTE BARANDILLA
SUPPORT GARDE-CORPS
SUPPORT BALUSTRADE
SUPPORTO BALAUSTRRA
INOX duplex 2205
5947/0.. 16,7-19 mm

inox s.s.	16,7-19mm	€/u
SIN TALADROS EN EL VIDRIO		

16,7-19 mm -> Substitución progresiva a: 16,7-21,52

**UTILAJES PARA ALINEACIÓN
DEL VIDRIO HASTA 17,52 mm**



UTILAJE ALINEACIÓN 180°
SUPPORT GARDE-CORPS
SUPPORT BALUSTRADE
SUPPORTO BALAUSTRRA
INOX duplex 2205
5980/001 16,7-19 mm

inox s.s.	16,7-19mm	€/u
SIN TALADROS EN EL VIDRIO		



UTILAJE ALINEACIÓN 90°
SUPPORT GARDE-CORPS
SUPPORT BALUSTRADE
SUPPORTO BALAUSTRRA
INOX duplex 2205
5981/001 16,7-19 mm

inox s.s.	16,7-19mm	€/u
SIN TALADROS EN EL VIDRIO		



UTILAJE ALINEACIÓN
SUPPORT GARDE-CORPS
SUPPORT BALUSTRADE
SUPPORTO BALAUSTRRA
INOX duplex 2205
5982/000 16,7-19 mm

inox s.s.	16,7-19mm	€/u
SIN TALADROS EN EL VIDRIO		



PINZAS PARA BARANDILLAS

INOX 316

CR. BILLO	PL. MATE	INOX BR	INOX SAT
CH. POLI	ANOD. M	INOX POLI	INOX SAT
BR. CHR	AN. CHR	P. S. S.	S. S. S.
CR. LUC.	AN. OPAC	INOX LUC.	INOX SAT
32	01	22	28

CR. BILLO	PL. MATE	INOX BR	INOX SAT
CH. POLI	ANOD. M	INOX POLI	INOX SAT
BR. CHR	AN. CHR	P. S. S.	S. S. S.
CR. LUC.	AN. OPAC	INOX LUC.	INOX SAT
32	01	22	28

inox s.s.	8-12,76	65x45	€/u
-----------	---------	-------	-----

*PINZAS KRONOS



SOPORTE VIDRIO BASE PLANA Y REDONDA
PINCE VERRE BASE PLATE
GLASS CLAMP FLAT BASE
MORSETTO VETRO BASE PIANA
INOX 316

SE VENDE EN CAJAS DE 4 UNIDADES

*1409/028 Ø42,4 - Ø48,3mm
*1411/028 8 - 12,76 mm

*o
*o

SOPORTE VIDRIO BASE PLANA
PINCE VERRE BASE PLATE
GLASS CLAMP FLAT BASE
MORSETTO VETRO BASE PIANA
ZAMAK

1415/032 6-10 mm

Zn	6-10mm	55x55	€/u
----	--------	-------	-----

SOPORTE VIDRIO BASE PLANA
PINCE VERRE BASE PLATE
GLASS CLAMP FLAT BASE
MORSETTO VETRO BASE PIANA
INOX 316

1410/022 6-8-10 mm

inox s.s.	6-8-10mm	40x50	€/u
-----------	----------	-------	-----

SOPORTE VIDRIO BASE PLANA
PINCE VERRE BASE PLATE
GLASS CLAMP FLAT BASE
MORSETTO VETRO BASE PIANA
INOX 316

1427/022 12 mm

inox s.s.	12mm	68x45	€/u
-----------	------	-------	-----

SOPORTE CRISTAL + SOPORTE
ESQUINA Y PIN SEGURIDAD
PINCE VERRE BASE PLATE +
SUPPORT ANGLE + ÉPINGLE SÛRETÉ
GLASS CLAMP FOR TUBE +
CORNER SUPPORT + SAFETY PIN
MORSETTO VETRO BASE PIANA +
APPOGGIO ANGOLO + PIN SICUREZZA
INOX 316

1422/022

inox s.s.	10-12mm	55x55	€/u
-----------	---------	-------	-----

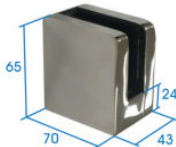

SOPORTE VIDRIO BASE PLANA
PINCE VERRE BASE PLATE
GLASS CLAMP FLAT BASE
MORSETTO VETRO BASE PIANA
INOX 316

1429/022 INOX 316

inox s.s.	8+8/10+10	55x55	€/u
SIN TALADROS EN EL VIDRIO			

SOPORTE VIDRIO BASE PLANA
PINCE VERRE BASE PLATE
GLASS CLAMP FLAT BASE
MORSETTO VETRO BASE PIANA
INOX duplex 2205

1424/022 10 mm

inox s.s.	10mm	55x55	€/u
-----------	------	-------	-----

GOMAS PARA VIDRIO DE 12 MM
CAOUTCHOUC POUR VERRE 12 MM
RUBBERS FOR 12 MM GLASS
GOMME PER VETRO DI 12 MM

1424/G12 12 mm
1424/G10 10 mm

SOPORTE INFERIOR VIDRIO
BASE INF. VERRE
GLASS BOTTOM SUPPORT
SUPPORTO INFERIORE VETRO
INOX duplex 2205

1424/B22

inox s.s.	10mm	55x55	€/u
-----------	------	-------	-----

SOPORTE CRISTAL PARA TUBO
PINCE VERRE POUR TUBE
GLASS CLAMP FOR TUBE
MORSETTO VETRO PER TUBO
*1416/031
*1416/034

Zn	6-10 mm	Ø 38-42	€/u
----	---------	---------	-----

SOPORTE CRISTAL PARA TUBO
PINCE VERRE POUR TUBE
GLASS CLAMP FOR TUBE
MORSETTO VETRO PER TUBO
*1421/0.. 10mm

inox s.s.	10mm	Ø 38-42	€/u
-----------	------	---------	-----

SOPORTE CRISTAL ESQUINERO
PINSE ANGULAIRES VERRE
CORNER CLAMP GLASS
MORSETTO ANGOLARE VETRO
INOX 316.

***1406/022 der. 8 mm**
droite/right/destra

***1408/022 izq. 8 mm**
gauche/left/sinistra

***1432/022 der. 10 mm**
droite/right/destra

***1433/022 izq. 10 mm**
gauche/left/sinistra

inox s.s.	8 ó 10mm	60x60	€/u
-----------	----------	-------	-----

se vende EN KIT 2 unidades.
kits vendus dans 2 unités
sold in kits 2 units
Si vende in kits di 2 unità

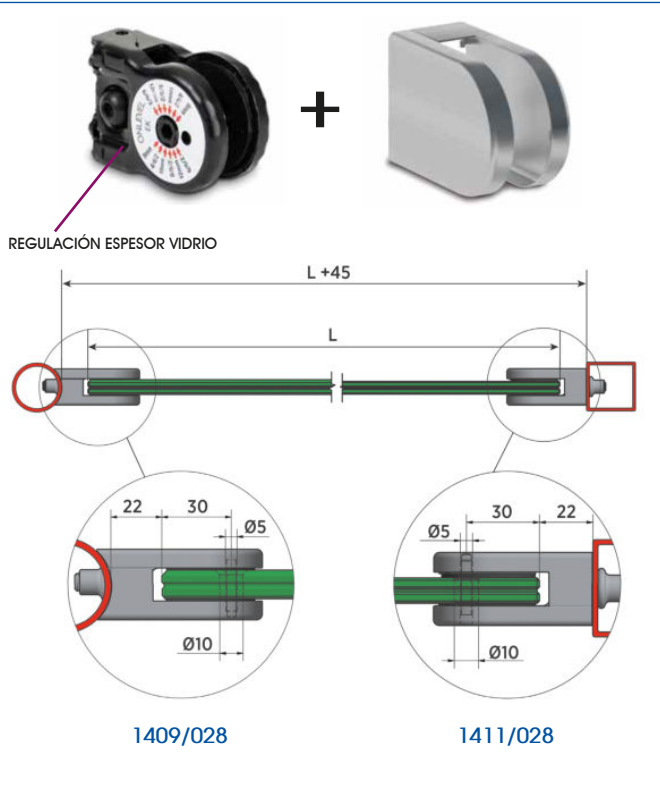

Dimensiones (mm)

		min.	max.
B	Anchura del vidrio	500	1000-1200 Recom.
T	Espesor del vidrio	Ver modelo correspondiente	Ver modelo correspondiente
H	Altura del vidrio	800	1000
h1	Distancia borde superior- barandilla	10	50 sin protección de borde 120 con protección de borde
h2	Distancia borde inferior-pavimento	10	50 sin protección de borde 120 con protección de borde
h3	Distancia borde superior-eje central de la pinza	100	150
h4	Distancia borde inferior-eje central de la pinza	100	150

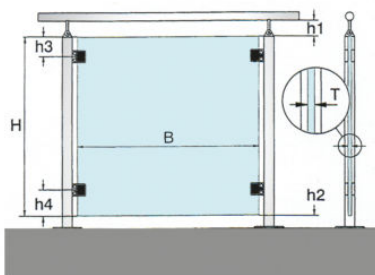

DISTANCIADORES

Ø 52mm



INOX DUPLEX 2205

ANCLAJE PARED-VIDRIO INOX DUPLEX 2205
ANCE MUR-VERRE
WALL-GLASS ANCHOR
ANCORAGGIO A PARETE IN VETRO
5327/D22 INOX DUPLEX 2205
5327/D28 INOX DUPLEX 2205

Ø 52mm



INOX 316

ANCLAJE PARED-VIDRIO INOX 304
ANCE MUR-VERRE
WALL-GLASS ANCHOR
ANCORAGGIO A PARETE IN VETRO
5326/022
5326/028

INOX 304

Ø 52mm



ANCLAJE PARED-VIDRIO INOX 304
ANCE MUR-VERRE
WALL-GLASS ANCHOR
ANCORAGGIO A PARETE IN VETRO
5314/022 INOX 304
5314/028 INOX 304
5314/00N INOX 304

NEGRO INOR BLACK NERO	PL.MATE ANOD.,M AN. CHR AN.OPAC	INOX BR INOX POLI P.S.S. INOX LUC	INOX SAT INOX SAT S.S.S. INOX SAT
00N	01	22	28

inox s.s.	Ø 52 mm	Ø20mm	€/u
	8-21,52 mm		

inox s.s.	Ø 52 mm	Ø20mm	€/u
	8-21,52 mm		

inox s.s.	Ø 38 mm	Ø24mm	€/u
	10-22 mm		

inox s.s.	desde 19 hasta 51mm	€/u
--------------	---------------------	-----

inox s.s.	Ø 35 mm	Ø20mm	€/u
	8-21,52 mm		

INOX BR INOX POLI P.S.S. INOX LUC	INOX SAT INOX SAT S.S.S. INOX SAT
22	28

inox s.s.	10-12mm	Ø 35	€/u
	Ø 26 mm	∇ Ø 32 mm	

inox s.s.	10-12mm	Ø 35	€/u
	Ø 26 mm	∇ Ø 32 mm	

inox s.s.	10-12 mm	Ø 35 mm	€/u
	Ø26 mm		

inox s.s.	15-21,5mm	Ø 35	€/u
	Ø 26 mm	∇ Ø 32 mm	



ANCLAJE PARED-VIDRIO
FIXATION MUR/VERRE
WALL-GLASS SUPPORT POINT
UNIONE PARETE-VETRO
*4324/022



ANCLAJE PARED-VIDRIO
FIXATION MUR/VERRE
WALL-GLASS SUPPORT POINT
UNIONE PARETE-VETRO
*4346/022



ANCLAJE PARED-VIDRIO
FIXATION MUR/VERRE
WALL-GLASS SUPPORT POINT
UNIONE PARETE-VETRO
*4346/P22



ANCLAJE PARED-VIDRIO
VIDRIO 16-22 mm
FIXATION MUR/VERRE 16-22 mm
SUPPORT WALL-GLASS 16-22 mm
UNIONE PARETE-VETRO 16-22 mm
*4347/022



LLAVE REGULABLE x TORNILLO
OUTIL RÉGLABLE x VIS
ADJUSTABLE TOOL SCREWS
UTENSILE REGOLABILE x VITI
4398/034

ZINCADO PL.ZNK ZNK.PL ZINCATO	34
--	----

DISTANCIADORES PARA
ESCALERAS DE VIDRIO

Ø 50mm



INOX DUPLEX 2205

ANCLAJE PARED-VIDRIO
FIXATION MUR/VERRE
WALL-GLASS SUPPORT POINT
UNIONE PARETE-VETRO
INOX duplex 2205
*5949/022

LLAVE MONTAJE ANCLAJES
OUTIL RÉGLABLE 19-51mm
ADJUSTABLE TOOL 19-51mm
UTENSILE REGOLABILE 19-51mm
5969/012

Ø 30mm



INOX 304

ANCLAJE PARED-VIDRIO INOX 304
ANCE MUR-VERRE
WALL-GLASS ANCHOR
ANCORAGGIO A PARETE IN VETRO
4307/022 INOX 304
4307/028 INOX 304
4307/00N INOX 304

inox s.s.	Ø 38 mm	Ø24mm	€/u
	10-22 mm		

inox s.s.	desde 19 hasta 51mm	€/u
--------------	---------------------	-----

inox s.s.	Ø 35 mm	Ø20mm	€/u
	8-21,52 mm		

5929



INOX 304

inox s.s.	Ø 50 mm	Ø16mm	€/u
	hasta 30 mm		

5928



ANCLAJE BARANDILLA+ESCALERA VIDRIO
ANCRAGE DE GARDE-CORPS+ESCALIER EN VERRE
RAILING ANCHORAGE+GLASS STAIRCASE
ANCORAGGIO RINGHIERA + SCALA IN VETRO
5929/028 INOX 304 VIDRIO-VIDRIO
5928/028 VIDRIO-PARED

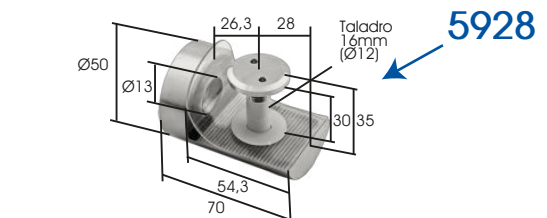
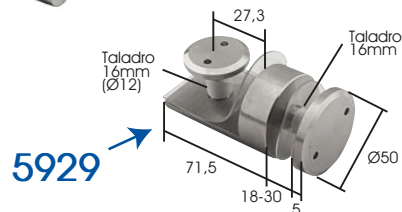

SOPORTES VIDRIO



SOPORTE BARANDILLA
SUPPORT GARDE-CORPS
SUPPORT BALUSTRADE
SUPPORTO BALAUSTRRA
INOX duplex 2205

*5970/022 12-21.5 mm



SOPORTE BARANDILLA
SUPPORT GARDE-CORPS
SUPPORT BALUSTRADE
SUPPORTO BALAUSTRRA
INOX duplex 2205

*5973/022 12-21.5 mm

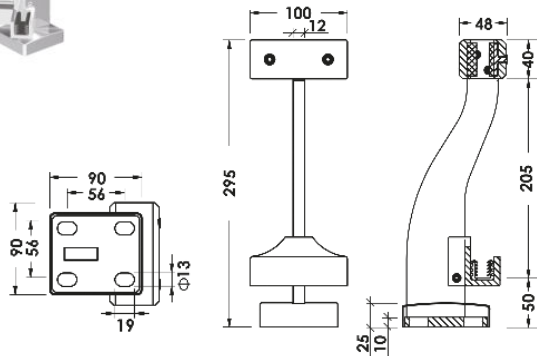

SOPORTE BARANDILLA
SUPPORT GARDE-CORPS
SUPPORT BALUSTRADE
SUPPORTO BALAUSTRRA
INOX duplex 2205

*5972/022 12-21.5 mm



SOPORTE BARANDILLA
SUPPORT GARDE-CORPS
SUPPORT BALUSTRADE
SUPPORTO BALAUSTRRA
INOX duplex 2205

*5971/022 12-21.5 mm

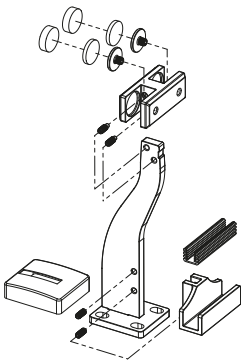

INOX BR
INOX POLI
P.S.S.
INOX LUC
22

inox s.s. 12-21.5mm €/u
SIN TALADROS EN EL VIDRIO

inox s.s. 12-21.5mm €/u
SIN TALADROS EN EL VIDRIO

INOX BR
INOX POLI
P.S.S.
INOX LUC
22

inox s.s. 12-21.5mm €/u
SIN TALADROS EN EL VIDRIO

inox s.s. 12-21.5mm €/u
SIN TALADROS EN EL VIDRIO

*PERFILES PASAMANOS

MÁXIMA GARANTÍA DE CALIDAD

GARANTIE DE QUALITE MAXIMALE
MAXIMUM QUALITY GUARANTEE
MASSIMA GARANZIA DI QUALITA

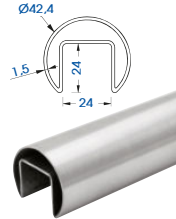

PROFILO PASAMANO Ø42,2
PROFIL GARDE-CORPS
BALUSTRADE PROFIL
PROFILO BALAUSTRRA
INOX 316L
*5100/122 Ø 42,4 mm

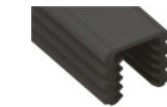

GOMA VIDRIO 12-13,52 MM
CAOUTCHOUC POUR LE VERRE
RUBBER FOR GLASS
GOMMA PER VETRO
*5107/10N 12-13,52 mm

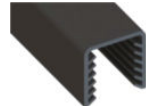

GOMA VIDRIO 16-19 MM
CAOUTCHOUC POUR LE VERRE
RUBBER FOR GLASS
GOMMA PER VETRO
*5108/10N 16-19 mm



GOMA VIDRIO 21,52 MM
CAOUTCHOUC POUR LE VERRE
RUBBER FOR GLASS
GOMMA PER VETRO
*5109/10N 21,52 mm



UNIÓN TUBO 90°
FIXATION 90°
90° JOINER
GIUNTO 90°
INOX duplex 2205
*5101/022 Ø 42,4 mm



UNIÓN TUBO 180°
FIXATION 180°
180° JOINER
GIUNTO 180°
INOX duplex 2205
*5102/022 Ø 42,4 mm



TAPÓN FINAL PROFIL 5100
COUVERTURE FINAL PROFIL
FINAL COVER PROFIL 5100
COPRITESTA PROFIL 5100
INOX duplex 2205
*5103/022 Ø 42,4 mm



UNIÓN PARED PROFIL 5100
FIXATION MUR PROFIL 5100
WALL PROFIL 5100 JOINER
GIUNTO PARTE PROFIL 5100
INOX duplex 2205
*5104/022 Ø 42,4 mm



PEGAMENTO
COLLE
GLUE RETEINING COMPUOND
COLLA
*5106/000 50 ml

ERUJO BRUT RAW GREZZO	NEGRE BLACK NERO	INOX BR INOX POLI P.S.S. INOX LUC	INOX SAT INOX SAT S.S.S. INOX SAT
00	0N	22	28
inox s.s. L	5,8 m	Ø42,4x1,5	€/m
Cau	12-13,52 mm		€/m
Cau	16-19 mm		€/m
Cau	21,52 mm		€/m
inox s.s.	Ø 42,4 mm		€/u
inox s.s.	Ø 42,4 mm		€/u
inox s.s.	Ø 42,4 mm		€/u
inox s.s.	Ø 42,4 mm		€/u
	50 ml		€/u

***DELPHOS**

BARANDILLAS DE VIDRIO
garde-corps en verre
glass balustrades
balaustre in vetro

Vidrio laminado y templado
Verre feuilleté et trempé
Laminated and tempered glass
Vetro laminato e temperato
6+6+2 mm (12,76 mm)
8+8+2 mm (16,76 mm)
10+10+2 mm (20,76 mm)

INOX SAT	AN. INOX	BRUTO
INOX SAT	AN. INOX	BRUTO
S.S.S.	AN. SS	RAW
INOX SAT	AN. INOX	GREZZO
28	08	00

VIDRIO 10+10

ALTURA MAX VIDRIO: 1200 mm
Hauteur max. verre: 1200 mm
Height max. glass: 1200 mm
Altezza mass. vetro: 1200 mm

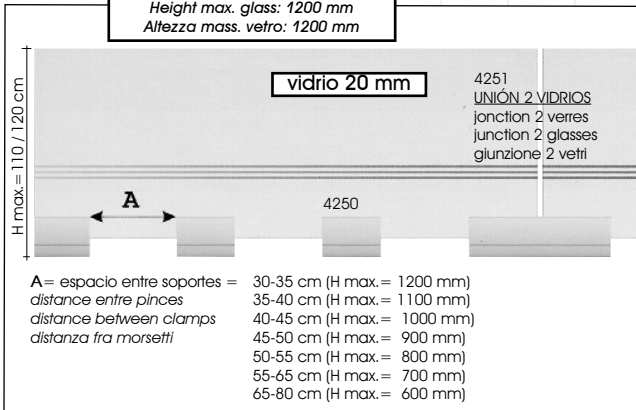

20 MM (10+10)

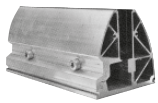

PINZA SUELO-VIDRIO 20 CM
PINCE SOL-VERRE 20 CM
CLAMP FLOOR-GLASS 20 CM
PINZA SUOLO-VERRO 20 CM
*4250/000

Al	200x140x120 mm	€/u
∞	4252	10+10+2mm
		*o

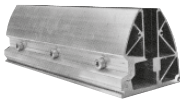

PINZA SUELO-VIDRIO 40 CM
PINCE SOL-VERRE 40 CM
CLAMP FLOOR-GLASS 40 CM
PINZA SUOLO-VERRO 40 CM
*4251/000

Al	400x140x120 mm	€/u
∞	4252	10+10+2mm
		*o



ANCLAJE M12-180 mm
ANCORAGE M12-180 mm
ANCHORAGE M12-180 mm
ANCORAGGIO M12-180 mm
*4237/180

Fe	galvaniz.	€/u
		*o

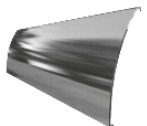

PERFIL TAPA
PROFIL COUVERTURE
COVER PROFIL
PROFILO COPERTINA
*4252/108

Al	6/3 m	h.140	€/m
∞	4251-4252		
			*o



REMATE FINAL
BOUCHON
END-CAP
COPRITESTA
*4253/028

inox s.s.	∞	4250-4251-4252	€/u
			*o



REMATE INTERMEDIO
BOUCHON INTERMÉDIAIRE
INTERMEDIATE END-CAP
COPRITESTA INTERMEDIO
*4254/028

inox s.s.	∞	4250-4251-4252	€/u
			*o

VIDRIO 8+8

ALTURA MAX VIDRIO: 1000 mm
Hauteur max. verre: 1000 mm
height max. glass: 1000 mm
altezza mass. vetro: 1000 mm

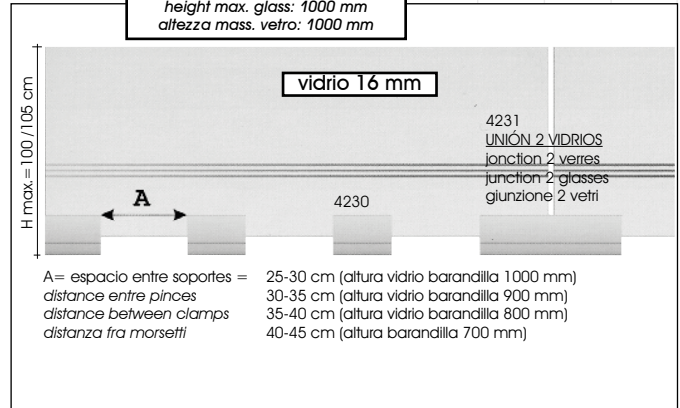

INOX SAT	AN. INOX	BRUTO
INOX SAT	AN. INOX	BRUTO
S.S.S.	AN. SS	RAW
INOX SAT	AN. INOX	GREZZO
28	08	00

16 MM (8+8)



PINZA SUELO-VIDRIO 30 CM
PINCE SOL-VERRE 30 CM
CLAMP FLOOR-GLASS 30 CM
PINZA SUOLO-VERRO 30 CM
*4230/000

Al	300 (200)x100x100	€/u
∞	4232	8+8+2 mm
		*o



PINZA SUELO-VIDRIO 40 CM
PINCE SOL-VERRE 40 CM
CLAMP FLOOR-GLASS 40 CM
PINZA SUOLO-VERRO 40 CM
*4231/000

Al	400 (300)x100x100	€/u
∞	4232	8+8+2 mm
		*o



ANCLAJE M10-120 mm
ANCORAGE M10-120 mm
ANCHORAGE M10-120 mm
ANCORAGGIO M10-120 mm
*4237/120

Fe	galvaniz.	€/u
		*o

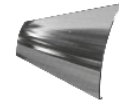

PERFIL TAPA
PROFIL COUVERTURE
COVER PROFIL
PROFILO COPERTINA
*4232/108

Al	6/3 m	h.100	€/m
∞	4230-4231		
			*o



REMATE FINAL
BOUCHON
END-CAP
COPRITESTA
*4233/028

inox s.s.	∞	4230-4231-4232	€/u
			*o



REMATE INTERMEDIO
BOUCHON INTERMÉDIAIRE
INTERMEDIATE END-CAP
COPRITESTA INTERMEDIO
*4236/028

inox s.s.	∞	4230-4231-4232	€/u
			*o



PERFIL TAPA CUADRADA
PROFIL COUVERTURE
COVER PROFIL
PROFILO COPERTINA
*4238/108

Al	6/3 m	92x49	€/m
∞	4230-4231		
			*o

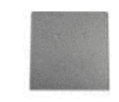

REMATE FINAL
BOUCHON
END-CAP
COPRITESTA
*4239/028

inox s.s.	∞	4230-4231-4232	€/u
			*o



REMATE INTERMEDIO
BOUCHON INTERMÉDIAIRE
INTERMEDIATE END-CAP
COPRITESTA INTERMEDIO
*4240/028

inox s.s.	∞	4230-4231-4232	€/u
			*o

PASAMANO MAIN CURRANTE-HANDRAIL-CORRIMANO

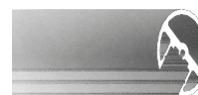

PASAMANO REDONDO
MAIN COURANTE RONDE
HANDRAIL ROUND PROFILE
CORRIMANO ROTONDO
*4234/108

Al	6/3 m	Ø50	€/m
∞	16-22mm		
			*o

MARQUESINAS

INOX BR	INOX SAT
INOX POLI	INOX SAT
P.S.S.	S.S.S.
INOX LUC	INOX SAT
22	28



ANCLAJE VIDRIO-PARED
SUPPORT MUR-VERRE
BRACKET WALL-GLASS
UNIONE PARETE-VERRO
4340/022

inox s.s.	12-16 mm	€/u
Ø	18 mm	



ANCLAJE PARED-TIRANTE
SUPPORT MUR-TIRANT
BRACKET WALL-TIE
UNIONE PARETE-TIRANTE
4341/022

inox s.s.	∞4343-4305	€/u
-----------	------------	-----



ANCLAJE VIDRIO-TIRANTE
SUPPORT VERRE-TIRANT
BRACKET GLASS-TIE
UNIONE VETRO-TIRANTE
4342/022

inox s.s.	12-16 mm	€/u
Ø	18 mm	



TIRANTE Ø 16 MM
TIRANT
TIE
TIRANTE
4343/022 1 m
*4343/122 1,25 m

inox s.s.	∞4342-4341	€/u
-----------	------------	-----



ANCLAJE VIDRIO-PARED DOBLE
SUPPORT MUR-VERRE DOUBLE
DOUBLE BRACKET WALL-GLASS
UNIONE DOPPIA PARETE-VERRO
*4306/022

inox s.s.	12-16 mm	€/u
Ø	18 mm	



ANCLAJE VIDRIO-TIRANTE DOBLE
SUPPORT VERRE-TIRANT DOUBLE
DOUBLE BRACKET GLASS-TIE
UNIONE DOPPIA VETRO-TIRANTE
*4305/022

inox s.s.	12-16 mm	€/u
Ø	18 mm	

KITS

inox s.s.	max. rec. 120 cm	€/u
-----------	------------------	-----

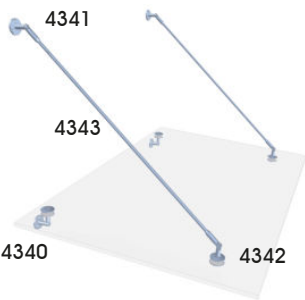

KIT 2 SOPORTES
4340/022 2 u.
4341/022 2 u.
4342/022 2 u.
4343/022 2 u.
4344/022



12-16mm (6+6, 8+8)

Max. 60 kg/conjunto (2 piezas)

* MINI CRUCETAS - MINI SPIDER

INOX SAT	INOX SAT
S.S.S.	INOX SAT
INOX SAT	
28	

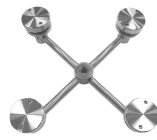

ANCLAJE 4 VIDRIOS USO INTERIOR
SPIDER 4 VOIES USAGE INTERIEUR
SPIDER 4 WAYS FOR INDOOR USE
SPIDER 4 VIE USO INTERNO
*1460/028

inox s.s.	100x100	€/u
Ø	12 mm	8-12 mm



ANCLAJE 2 VIDRIOS 45° USO INTERIOR
SPIDER 2 VOIES USAGE INTERIEUR
SPIDER 2 WAYS 45° FOR INDOOR USE
SPIDER 2 VIE 45° USO INTERNO
*1461/028

inox s.s.	100x50	€/u
Ø	12 mm	8-12 mm



ANCLAJE 2 VIDRIOS 180° USO INTERIOR
SPIDER 2 VOIES 180° USAGE INTERIEUR
SPIDER 2 WAYS 180° FOR INDOOR USE
SPIDER 2 VIE 180° USO INTERNO
*1462/028

inox s.s.	100 mm	€/u
Ø	12 mm	8-12 mm



ANCLAJE 1 VIDRIO 45° USO INTERIOR
SPIDER 1 VOIE USAGE INTERIEUR
SPIDER 1 WAY 45° FOR INDOOR USE
SPIDER 1 VIA 45° USO INTERNO
*1463/028

inox s.s.	50x50	€/u
Ø	12 mm	8-12 mm

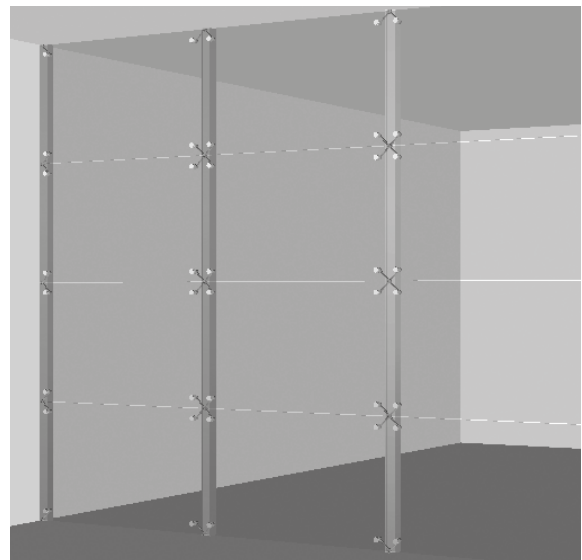

VENTOSAS



VENTOSA ELÉCTRICA Y MANUAL
ventouse électrique et manuelle
electric and manual suction cup
ventosa elettrica e manuale
Inx **9187/000** €/u.



VENTOSA ELÉCTRICA
ventouse électrique
electric suction cup
ventosa elettrica
Inx **9186/000** €/u.



VENTOSA CON MANÓMETRO
ventouse
suction cup
ventosa
Inx **9185/000** €/u.



VENTOSA SIMPLE
ventouse simple
simple suction cup
semplice ventosa
Al **9184/000** €/u.



VENTOSA DOBLE
double ventouse
double suction cup
doppia ventosa
Al **9181/000** €/u.



VENTOSA TRIPLE
triple ventouse
triple suction cup
tripla ventosa
Al **9180/000** €/u.



VENTOSA CON BOMBA DE VACÍO
VENTOUSE À POMPE 1 COUP
PUMP SUCTION LIFTER 1 CUP
VENTOSA CON POMPA A VUOTO
Maletin incluido
*9198/000Bs

ABS	Ø 200 mm	€/u
V: 60 kg/u	H: 95 kg/u	



VENTOSA CON BOMBA DE VACÍO
VENTOUSE À POMPE 1 COUP
PUMP SUCTION LIFTER 1 CUP
VENTOSA CON POMPA A VUOTO
Maletin incluido
*9197/000Bs

ABS	Ø 200 mm	€/u
V: 80 kg/u	H: 100 kg/u	

ACCESORIOS VIDRIO



GAFAS SEGURIDAD
LUNETTES DE PROTECTION
GOGGLES
OCCHIALI DI SICUREZZA
*9117/000 €/u.



LÁPIZ
CRAYON
PENCIL
MATITA
*9120/0V ROJO, ROUGE, RED, ROSSO
*9120/0B AZUL, BLEU, BLUE, BLU



ROTULADOR
MARQUEUR
FELT PEN
PENNARELLO
*9122/0V ROJO, ROUGE, RED, ROSSO
*9122/0N NEGRO, NOIR, BLACK NERO



PASTILLA AFILADORA BROCAS DIAMANTADAS
PIERRES À AVIVER LES FORETS
BIT BRIGHTENING STONE
PIETRA AFFILATRICE DI PUNTE DIAMANTATE
*9110/000 €/u.

OTROS ACCESORIOS VIDRIO

HERRAMIENTAS DE CORTE



RULINA LUBRICADA
COUPE-VERRE LUBRIFIÉ
GLASS-CUTTER LUBRICATED
TAGLIAVETRO LUBRIFICATO
9048/000 €/u.



RULINA SILBERSCHNITT
COUPE-VERRE SILBERSCHNITT
GLASS-CUTTER SILBERSCHNITT
TAGLIAVETRO SILBERSCHNITT
*9060/000

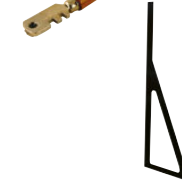

ESCUADRA
ÉQUERRE
L SQUARE
SQUADRA
*9072/060 60 cm



BASTIDOR DE CORTE
GABARIT DOUBLE À GLISSIÈRE
SLIDING DOUBLE GAUGE
SQUADRA TAGLIO SCOREVOLE
*9070/040 40 cm
*9070/060 60 cm



CORTA CÍRCULOS CON VENTOSA
TOURNETTE AVEC VENTOUSE
ROUND CUTTER WITH SUCTION LIFT
COMPASSO TAGLIO CON VENTOSA
*9079/040 h.40cm
*9079/120 h.120cm



PLANTILLA CORTE CURVOS
MODÈLE COUPE CURVILIGNE
CURVILINEAR CUTTING TOOL
CURVILINEA TAGLIO
*9080/000



TENAZA REMORDER
PINCE À BEC PLAT À DÉTACHER
FLATNOSE SNAP-OFF PLIERS
TENAGLIA
*9085/200



TENAZA REMORDER
PINCE À BEC PLAT À DÉTACHER
FLATNOSE SNAP-OFF PLIERS
TENAGLIA
*9085/180



TENAZA PICO DE LORO
PINCE À BEC DE PERROQUET
PARROT NOSE PLIERS
TENAGLIA
*9086/000

BROCAS DIAMANTADAS



BROCAS DIAMANTADAS
FORETS DIAMANTÉS
DIAMOND TIPPED DRILLS
PUNTE DIAMANTATE
*9107/040 4mm
*9107/050 5mm
*9107/060 6mm
*9107/070 7mm
*9107/090 9mm
*9107/140 14mm
*9107/180 18mm
*9107/260 26mm
*9107/360 36mm
*9107/380 38mm
*9107/460 46mm
*9107/550 55mm

PARA OTRAS MEDIDAS
CONSULTAR.

DISCOS Y BANDAS



DISCO VERDE SUPER FUERTE
DISQUE VERT TRÉS GROS
DISK GREEN VERY STRONG
DISCO VERDE EXTRA FORTE

*9008/220 g.220



DISCO NEGRO FUERTE
DISQUE NOIR GROS
DISK BLACK STRONG
DISCO NERO FORTE

*9008/12N g.120
*9008/22N g.220



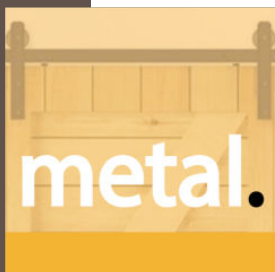

METAL

HERRAJES VIDRIO Y MADERA

KARR 1 Y KARR 3

CORREDERA PLÁSTICO "U" Y "L"

CERRADURAS VITRINAS

BISAGRAS VITRINAS

SIN MUESCA O TALADRO
CON MUESCA O TALADRO

PORTAESTANTES

COMPLEMENTOS

UNIÓN ESTANTERÍA
DISTANCIADOR RÓTULOS
SEPARADOR MOSTRADOR
COMPLEMENTOS ESPEJOS
LAMPARA "UV"
ACCES. PEGAMENTO "UV"

DIS-PLAY

CLICK

KITS Y COMPONENTES

FACILPLUS Y ARPLUS

KITS Y COMPONENTES

GAMA PREMIUM

HERRAJES ALTA GAMA - PUERTA PANAMÁ AUTOM. MAGN. MADERA

KITS
MONTAJE
CARACTERÍSTICAS

PUERTA PANAMÁ INVISIBLE MAGNÉTICA MADERA

KITS
CONFIGURACIÓN

FAMILIA CANTÓN - CANTÓN INVISIBLE MADERA (MANUAL)

KITS
CONFIGURACIÓN

CANTÓN MADERA

KITS Y COMPONENTES
PERFIL EMPOTRAR TECHO

CANTÓN TELEX MADERA 2

KITS Y COMPONENTES
MEDIDAS Y MONTAJE

CANTÓN TELEX MADERA 3

KITS Y COMPONENTES
MEDIDAS Y MONTAJE

LIMA

MATEK

KITS Y COMPONENTES

GAMA PREMIUM

HERRAJES ALTA GAMA - FH9 -BISAGRA HIDRÁULICA OCULTA MADERA

KITS
INF. Y DATOS TÉCNICOS

FH10 - BISAGRA HIDRÁULICA

KITS
INF. Y DATOS TÉCNICOS

FH6 - BISAGRA HIDRÁULICA CARACTERÍSTICAS

FH5 - BISAGRA HIDRÁULICA CARACTERÍSTICAS

FH3 - AMORTIGUADOR HIDRÁULICO OCULTO

INF. Y DATOS TÉCNICOS

AH8 - AMORTIGUADOR HIDRÁULICO OCULTO

INF. Y DATOS TÉCNICOS

AH7 - AMORTIGUADOR HIDR. INF. Y DATOS TÉCNICOS

SH1 - STOP HIDR. UNIVERSAL INF. Y DATOS TÉCNICOS

B150 - BISAGRA OCULTA CARACTERÍSTICAS

SMART-LOCKS MADERA

HIDRO

KARR 3 VIDRIO DE HASTA 10 MM

ALTURA PUERTA HASTA 2,5 m Ó 25 kg/COJINETE
VERRE MAX. 10 mm, HAUTEUR MAX. 2,5 m OU 25 kg/CHARLOT
GLASS MAX. 10 mm, HEIGHT MAX. 2,5 m OR 25 kg/ROLLER
VETRO MASS. 10 mm, ALTEZZA MASSIMA 2,5 m
O 25 kg/CUSCINETTO

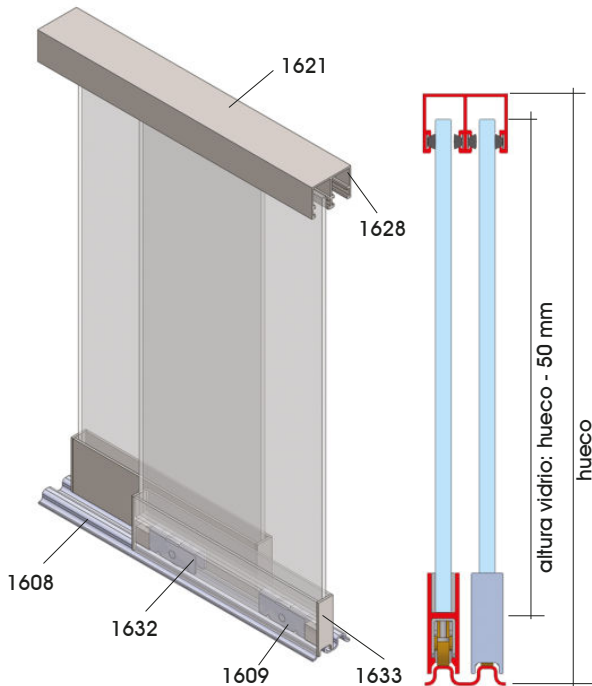

PL. M ALU. M ALU. M ALL. NAT	BLANCO BLANC WHITE BIANCO	NEGRO NOIR BLACK NERO	COLOR COULEUR COLOR COLORE	BRUTO BRUT RAW GREZZO
01	0B	0N	0P	00

	CARRIL SUPERIOR SIMPLE COULISSE HAUTE UPPER SIMPLEE TRACK GUIDA SUPERIOR SEMPLICE 1607/1..	Al	5 m	20x15x20x2					€/m
	CARRIL SUPERIOR SIMPLE COULISSE HAUTE UPPER SIMPLEE TRACK GUIDA SUPERIOR SEMPLICE 1640/1..	Al	5 m	30x18x30x2					€/m
	SUPERIOR DOBLE FELPA COULISSE HAUTE DOBLE UPPER DOUBLE TRACK GUIDA SUPERIOR DOPPIA 1621/1..	Al	5 m	∞ 1628					€/m
	CASACA VIDRIO PROFIL VERRE PROFILE GLASS PROFILO VETRO 1608/1..	Al	5 m	max.10 mm					€/m
	CARRIL INFERIOR DOBLE RAIL DOBLE INFERI LOWER DOUBLE RAIL BINARIO DOPPIO INF. 1609/128	inox s.s.	5 m						€/m
	COJINETE HIERRO GALET ACIER METALLIC ROLLER PATTINO METAL. SCORREV 1632/000	Fe	25 kg/u						€/u
	PALA METÁLICA EMBOUET METAL METALLIC END-CAP COPRITESTA METALLICO 1633/0..	Fe							€/u
	FELPA BROSSER BRUSH 1628/109	plas	325 m						€/m

VITRINAS CORREDERAS

M.150 "U" y "L"



METAL

COMPLEM. VIDRIO Y MADERA

CORREDERA PLÁSTICO

PLÁSTICO PLASTIQUE PLASTIC PLASTICA	COLOR COULEUR COLOR COLORE
09	0P

SUPERIOR DOBLE
COULISSE HAUTE DOBLE
UPPER DOUBLE TRACK
GUIDA SUPERIOR DOPPIA

1682/10P MARRÓN, BRUN, BROWN, MARRONE
1681/109 TRANSP.

CARRIL INFERIOR DOBLE
RAIL DOBLE INFERIEUR
LOWER DOUBLE RAIL
BINARIO DOPPIO INF.

1684/10P MARRÓN, BRUN, BROWN, MARRONE
1683/109 TRANSP.

"U" y "L"

PL. M ALU. M ALU. M ALL. NAT	ORO M DORÉ M GOLD M DOR. OP	BLANCO BLANC WHITE BIANCO	NEGRO NOIR BLACK NERO	COLOR COULEUR COLOR COLORE
01	03	0B	0N	0P

ÁNGULO 15x15 mm
PROFIL EN "L" 20X20
PROFIL "L" SHAPE 20X20
PROFILO ANGOLARE 20X20

1650/1..

ÁNGULO 20x20 mm
PROFIL EN "L" 20X20
PROFIL "L" SHAPE 20X20
PROFILO ANGOLARE 20X20

1651/1..

ÁNGULO 25x25 mm
PROFIL EN "L" 25X25
PROFIL "L" SHAPE 25X25
PROFILO ANGOLARE 25X25

1652/1..

ÁNGULO 30x30 mm
PROFIL EN "L" 30X30
PROFIL "L" SHAPE 30X30
PROFILO ANGOLARE 30X30

1653/1..

"U" 10x10x10 mm
PROFIL EN "U" 10X10X10
PROFIL "U" SHAPE 10X10X10
PROFILO "U" 10X10X10

1656/1..

"U" 12x12x12 mm
PROFIL EN "U" 12X12X12
PROFIL "U" SHAPE 12X12X12
PROFILO "U" 12X12X12

1657/1..

"U" 15x15x15 mm
PROFIL EN "U" 15X15X15
PROFIL "U" SHAPE 15X15X15
PROFILO "U" 15X15X15

1659/1..

"U" 20x15x20 mm
PROFIL EN "U" 20X15X20
PROFIL "U" SHAPE 20X15X20
PROFILO "U" 20X15X20

1607/1..

"U" 30x18x30 mm
PROFIL EN "U" 30X18X30
PROFIL "U" SHAPE 30X18X30
PROFILO "U" 30X18X30

1640/1..

"L" INOX PULIDO
L INOX POLI
L POL. STAINLESS STEEL
L INOX LUCIDO

*4373/122 20x20x1 mm
*4374/122 25x25x1 mm

INOX BR INOX POLI P.S.S. INOX LLC	INOX S.S.	3	€/m
22			

CERRADURAS VITRINAS



CERRADURA LÁPIZ
SERRURE VERRE AVEC TRAU
LOCK FOR DRILLED GLASS
SERRATURA VETRO FORATO

1500/032 MISMA LLAVE
même comb. keyed alike stessa chiave

CERRADURA DE SERRETA
SERRURE CRÉMAILLÈRE AMOVIBLE
RATCHET LOCK
SERRATURA CREMAGLIERA

1502/032 DISTINTA LLAVE
comb. variée, differ key, chiave distinta
1501/032 MISMA LLAVE
même comb. keyed alike stessa chiave

CERRADURA PULSADOR
SERRURE PORTES COULISSANTES
SLIDING DOOR LOCK
SERRATURA PER SCORREVOLI

1497/0.. MISMA LLAVE
même comb. keyed alike stessa chiave

CERRADURA PALA
SERRURE PORTES COULISSANTES
SLIDING DOOR LOCK
SERRATURA PER SCORREVOLI

1504/0.. MISMA LLAVE
même comb. keyed alike stessa chiave

CERRADURA VITRINA
SERRURE AVEC TRAU
DRILLED GLASS LOCK
SERRATURA VETRO FORATO

1505/032 MISMA LLAVE
même comb. keyed alike stessa chiave

CERRADURA PUERTA BATIENTE
SERRURE PORTE BATTANTE
SWINGING DOOR LOCK
SERRATURA PORTA BATTENTE

1495/032 MISMA LLAVE
même comb. keyed alike stessa chiave

CONTRACERRADURA VIDRIO SIN MUESCA
GAÛCHE VERRE SANS ENCOCHE
GLASS STRIKE WITHOUT CUT-OUT
CONVIROSERRATURA VETRO SENZA TACCA

1491/032

CERRADURA 2 PUERTAS BATIENES
SERRURE 2 PORTES BATTANTE
SWINGING 2 DOORS LOCK
SERRATURA 2 PORTE BATTENTI

1496/032 MISMA LLAVE
même comb. keyed alike stessa chiave

CERRADURA PUERTA BATIENTE
SERRURE PORTE BATTANTE
SWINGING DOOR LOCK
SERRATURA PORTA BATTENTE

*1508/032 DISTINTA LLAVE
comb. variée, differ key, chiave distinta

CERRADURA x PUERTA ALUMINIO
SERRURE x PORTE D'ALUMINIUM
LOCK x ALUMINIUM DOOR
SERRATURA x PORTA DI ALLUMINIO

*1479/031 DISTINTA LLAVE
comb. variée, differ key, chiave distinta

BISAGRA PIVOTANTE CON CERRADURA + BISAGRA SUPERIOR SIN CERRADURA
CHARNIÈRE DE PIVOTEMENT AVEC SERRURE + CHARNIÈRE SUP.
PIVOTING HINGE WITH LOCK+ UPPER HINGE
CERNIERA CARDINE CON SERRATURA+ CERNIERA SUP.

*1966/032 der. sup.
*1965/032 der. inf.

CR. BRILLO CHR. POLI BR. CHR CR. LLC.	CR. MATE CHR. M M. CHR CR. OPAC	CR. ORO CHR. DOR GOLD. C CR. ORO
32	31	33

Zn 6 mm 16 16 €/u
∞ KARR 1 - KARR 2

Zn 4-8 mm 16 16 €/u

Zn ∞ KARR system 16 16 €/u

Zn ∞ KARR 1 16 16 €/u

Zn 5-6 mm 16 16 €/u

Zn 4-6 mm 16 16 €/u

Zn 4-6 mm 16 16 €/u
∞ 1495

Zn 4-6 mm 16 16 €/u

Zn 5-10 mm 19 19 €/u

Zn 19 21 mm 16 16 €/u
fresado en el aluminio
fraisage en aluminium
milling in aluminium
fresatura nell'aluminio

Cu 6-8 mm 18 kg/2u 16 16 €/u
55x30

Se venden en JUEGOS DE 2 U. DERECHA
JEUX 2 UNITÉS, DROITE
SET 2 PIECES, RIGHT
SET 2 PEZZI, DESTRA

BISAGRAS VITRINA

SIN MUESCA O TALADRO

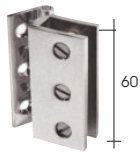

BISAGRA PARED-VIDRIO
CHARNIÈRE MUR-VERRE
HINGE WALL-GLASS
CERNIERA PARETE-RETRO
1950/032



BISAGRA VIDRIO-VIDRIO 180°
CHARNIÈRE VERRE-VERRE 180°
HINGE GLASS-GLASS 180°
CERNIERA VETRO-VETRO 180°
1951/032



BISAGRA PARED-VIDRIO
CHARNIÈRE MUR-VERRE
HINGE WALL-GLASS
CERNIERA PARETE-RETRO
1963/032



BISAGRA VIDRIO-VIDRIO 90°
CHARNIÈRE VERRE-VERRE 90°
HINGE GLASS-GLASS 90°
CERNIERA VETRO-VETRO 90°
1964/032



BISAGRA VIDRIO-VIDRIO 180°
CHARNIÈRE VERRE-VERRE 180°
HINGE GLASS-GLASS 180°
CERNIERA VETRO-VETRO 180°
1953/032



SET BISAGRA CAZOLETA
CHARNIÈRE DE PIVOTEMENT
PIVOTING HINGE
CERNIERA CARDINE
1954/S32

JUEGOS DE 2 UNIDADES
JEUX DE 2 UNITÉS
SET 2 PIECES
SET 2 PEZZI



SET BISAGRA CAZOLETA
CHARNIÈRE DE PIVOTEMENT
PIVOTING HINGE
CERNIERA CARDINE
1522/S22

JUEGOS DE 2 UNIDADES
JEUX DE 2 UNITÉS
SET 2 PIECES
SET 2 PEZZI



SET IMÁN
JEU D'AIMANTS
MAGNET SET
SET DI MAGNETI
1509/022



TIRADOR
BOUTON
KNOB
POMOLO
*1529/0...

CR. BRILLO CHR. POLI BR. CHR. CR. LUC.	NEGRO NOIR BLACK NERO	CR. MATE CHR. M M. CHR. CR. OPAC	32	ON	31
Cu	4-8 mm	5 kg/u	€	u	
60x32	0°-90°				
					o
Cu	4-8 mm	5 kg/u	€	u	
60x57	0°-90°				
					o
Cu	4-6 mm	2,5 kg/u	€	u	
25x20	0°-90°				
					o
Cu	4-6 mm	2,5 kg/u	€	u	
25x16	0°-180°				
					o
Cu	4-6 mm	2,5 kg/u	€	u	
25x57	0°-180°				
					o
Cu	6-8 mm	12 kg/2u	€	u	
40x27					
					o
inox s.s.	4-6 mm	40x22	€	u	
12 kg/2u					
					o
inox s.s.	4-6 mm		€	u	
					o
			Zn	€	u
					o
					o

CON MUESCA O TALADRO



SET BISAGRAS PIVOTANTES
CHARNIÈRE DE PIVOTEMENT
PIVOTING HINGE
CERNIERA CARDINE
1961/S32

JUEGOS DE 2 UNIDADES
JEUX DE 2 UNITÉS
SET 2 PIECES
SET 2 PEZZI



BISAGRA PARED-VIDRIO
CHARNIÈRE MUR-VERRE
HINGE WALL-GLASS
CERNIERA PARETE-RETRO
1957/032



BISAGRA VIDRIO-VIDRIO 180°
CHARNIÈRE VERRE-VERRE 180°
HINGE GLASS-GLASS 180°
CERNIERA VETRO-VETRO 180°
1958/032



BISAGRA GOLPE ARREMETIDA
CHARNIÈRE ANGULAIRE
CORNER HINGE
CERNIERA A SCATTO
1956/032



SET BISAGRAS GOLPE ARREMETIDAS
CHARNIÈRE ANGULAIRE
CORNER HINGE
CERNIERA A SCATTO
1516/S32

JUEGOS DE 2 UNIDADES
JEUX DE 2 UNITÉS
SET 2 PIECES
SET 2 PEZZI



BISAGRA GOLPE ARREMETIDA INTERMEDIA
CHARNIÈRE CENTRALE
CENTRAL HINGE
CERNIERA A SCATTO INTERMEDIA
1452/0..



BISAGRA PIVOTANTE
CHARNIÈRE DE PIVOTEMENT
PIVOTING HINGE
CERNIERA CARDINE
***1967/032**

JUEGOS DE 2 UNIDADES
JEUX DE 2 UNITÉS
SET 2 PIECES
SET 2 PEZZI



BISAGRA GOLPE ARREMETIDA
CHARNIÈRE ANGULAIRE
CORNER HINGE
CERNIERA A SCATTO
***1468/032**



PLACA PARA TRANSFORMAR LA BISAGRA 1468 EN VIDRIO-VIDRIO
PLAQUE POUR TRANSFORMER LE CHARNIÈRE 1468 EN VERRE-VERRE
PLATE TO TRANSFORM THE 1468 HINGE IN GLASS-GLASS
PIASTRA PER TRASFORMARE LA CERNIERA 1468 IN VETRO-VETRO
***1469/032**

CR. BRILLO CHR. POLI BR. CHR. CR. LUC.	NEGRO NOIR BLACK NERO	CR. MATE CHR. M M. CHR. CR. OPAC	32	ON	31
Zn	6-8 mm	18 kg/2u	€	u	
65x40					
					o
Cu	6-8 mm	10 kg/u	€	u	
43x40	0°-90°				
					o
Cu	6-8mm	10 kg/u	€	u	
40x80	0°-90°				
					o
Cu	6-8 mm	10 kg/u	€	u	
46x48	0°-90°				
					o
Zn	4-5 mm	40x30	€	u	
10 kg/2u					
					o
Cu	8-10 mm	20 kg/2u	€	u	
					o
					o
Zn	5-6 mm	3 kg/2u	€	u	
					o
					o

PORTAESTANTES

CR. BRILLO	CR. MATE
CHR. POLI	CHR. M
BR. CHR	M. CHR
CR. ILLC.	CR. OPAC
32	31



PORTAESTANTE MEDIALUNA
PINCES POUR TABLETTES
BRACKETS FOR SHELVES
PORTAMENSOLE
1513/0.. 6 mm

Zn	6-8-10mm
49x25	€/u

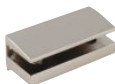

PORTAESTANTE RECTANGULAR
PINCES POUR TABLETTES
BRACKETS FOR SHELVES
PORTAMENSOLE
*1510/0.6mm

Zn	6-8-10mm
55x25	€/u



SOPORTE ESTANTES CILINDRO
PINCES POUR TABLETTES
BRACKETS FOR SHELVES
PORTAMENSOLE
1538/0.. 6mm

Zn	6 mm
15x27	€/u



1539/0.. 8/10mm

8-10 mm	∅ 195x27
---------	----------

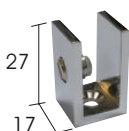

SOPORTE VIDRIO BASE PLANA
PINCE VERRE BASE PLATE
GLASS CLAMP FLAT BASE
MORSETTO VETRO BASE PIANA
1540/032 6-10 mm

inox s.s.	6-10	17x27	€/u
-----------	------	-------	-----



PORTEESTANTE VIDRIO-VIDRIO
Vidrio 8-10 mm (base)
6-8 mm (estante)
TAQUET SUPPORT BRACKET
Verre avec trous 8-10 mm
Verre tablette 6-8 mm
FITTING FOR GLASS SHELF
Glass drilled 8-10 mm
Glass shelf 6-8 mm
ACCESSORIO PER MENSOLA VETRO
Vetro con foro 8-10 mm
Vetro mensola 6-8 mm
4959/032

Cu	∅10 mm
6-8mm	8-10mm
	€/u



PINZA PELICANO GRANDE
PINCE "PELICAN XL"
BRACKET "PELICAN XL"
PORTAMENSOLA "PELICANO XL"
91/032
91/031

Zn	6-35mm	€/u
105x75		



PINZA PELICANO MEDIANA
PINCE "PELICAN M"
BRACKET "PELICAN M"
PORTAMENSOLA "PELICANO M"
94/032
94/031

Zn	6-29mm	€/u
75x55		



PINZA PELICANO PEQUEÑA
PINCE "PELICAN S"
BRACKET "PELICAN S"
PORTAMENSOLA "PELICANO S"
92/032
92/031

Zn	6-12mm	€/u
40x36		

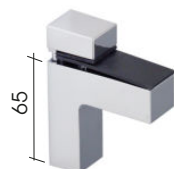

PINZA CUADRADA GRANDE
PINCE CARRÉE
SQUARE BRACKET
MORSETTO QUADRATO
*95/032

Zn	6-42mm	€/u
75x66		

COMPLEMENTOS

CR. BRILLO	INOX	BR
CHR. POLI	INOX	POLI
BR. CHR	P.S.S.	
CR. ILLC.	INOX	ILLC
32	22	

UNIÓN ESTANTERÍA



ESCUADRA METÁLICA 3 VIDRIOS
SUPPORT ANGULAIRE 3 VERRES
ANGULAR SUPPORT 3 GLASSES
SUPPORTO ANGOLARE 3 VETRI
1518/032

Fe	∅ 5	max.8mm	€/u
----	-----	---------	-----



ESCUADRA METÁLICA 2 VIDRIOS
SUPPORT ANGULAIRE 2 VERRES
ANGULAR SUPPORT 2 GLASSES
SUPPORTO ANGOLARE 2 VETRI
1519/032

Fe	∅ 5	max.8mm	€/u
----	-----	---------	-----



APOYO FINAL ESTANTE
TAQUET ÉTAGÈRE FINALE
FINAL SHELF SUPPORT
SUPPORTO FINALE MENSOLA
1520/L32

Cu	∅ 8	max.10mm	€/u
----	-----	----------	-----



APOYO INTERMEDIO 2 ESTANTES
TAQUETS INTERMÉDIAIRE 2 ÉTAGÈRES
INTERMEDIATE 2 SHELVES SUPPORT
SUPPORTO INTERMEDIO 2 MENSOLA
1521/L32

Cu	∅ 8	max.10mm	€/u
----	-----	----------	-----

DISTANCIADOR RÓTULOS



DISTANCIADOR VIDRIO AVELLANADO
ESPACEUR AVEC TROU FRAISÉE
SPACER WITH COUNTERSUNK DRILL
SEPARATORE CON FORO SVASATO
1930/032

Cu	8-10mm	∅ 19	€/u
	∅ 8 mm	∇ ∅ 19 mm	

SEPARADOR MOSTRADORES



DISTANCIADOR VIDRIO AVELLANADO
ESPACEUR AVEC TROU FRAISÉE
SPACER WITH COUNTERSUNK DRILL
SEPARATORE CON FORO SVASATO
1925/0..102mm

Cu	8-10mm	∅ 19	€/u
	∅ 8 mm	∇ ∅ 19 mm	



PASAMONEDAS
PASSAMONNAIE
MONEY HATCH
PASSAMONETE
1665/022

inox s.s.	41x31x4 cm	255x350	€/u
-----------	------------	---------	-----

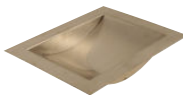

PASAMONEDAS
PASSAMONNAIE
MONEY HATCH
PASSAMONETE
1666/022

inox s.s.	26x21x4 cm	155x205	€/u
-----------	------------	---------	-----



PASAMONEDA BLINDADA
PASSAMONNAIE BLINDÉ
ARMOURED MONEY HATCH
PASSAMONETE BLINDATO
1667/022

inox s.s.	41x31x7 cm	255x350	€/u
-----------	------------	---------	-----

COMPLEMENTOS ESPEJOS



VENTOSA TRANSPARENTE
VENTOUSE
SUCTION
VENTOSA
2556/009

PLÁSTICO	PLASTIQUE	PLASTIC	PLASTICA
09			
plas	∅14	€/u	
			o



VENTOSA TRANSPARENTE
VENTOUSE
SUCTION
VENTOSA
319/009

plas	∅20	€/u	
			o

COMPLEMENTOS ESPEJOS



GRAPA INOX DE MUELLE
PALTES INOX AVEC RESSORT
STAINLESS STEEL CLAMP WITH SPRING
GRAPPA INOX CON MOLLA
1664/022
PRECIO DE:
1 SET DE 4 UNIDADES

CR. BRILLO	BLANCO	ZINCADO	INOX BR
CR. POLI	BLANC	PL. ZNK	INOX POLI
CR. CHR	WHITE	ZNK PL	P. S. S.
CR. ILLC.	BIANCO	ZINCATO	INOX ILLC
32	0B	34	22

inox	set 4 u.	€/u	
s.s.			o



SOPORTE ESPEJO Y FOCO
SUPPORT MIRROR ET SPOT
MIRROR AND SPOT SUPPORT
SUPPORTO SPECCHIO E SPOT
1542/034 60cm
1548/034 10cm

Fe		€/u	
			o

CINTA ADHESIVA 2 CARAS
RUBAN ADHÉSIF DOUBLE FACE
DOUBLE FACED ADHESIVE TAPE
NASTRO BIADESIVO
1545/00B 12X0,8
1546/00B 19X0,8

plas	66 m	€/u	
			o

BRUTO	INOX SAT
BRUT	INOX SAT
RAW	S. S. S.
GREZZO	INOX SAT
00	28

LAMPARA "UV"



IRRADIADOR "UV" 250W "UVAHAND"
LAMPE "UV" 250W "UVAHAND"
"UV" LAMP 250W "UVAHAND"
LAMPADA "UV" W "UVAHAND"
***9132/000**

250 W	€/u	
		*o

ACCESORIOS PARA PEGAMENTO "UV"



CERRADURA VID-VID. 180° x PEGAMENTO "UV"
SERRURE VERRE-VERRE 180° x COLLAGE "UV"
GLASS-GLASS 180° LOCK x "UV" GLUE
SERRATURA VETRO-VETRO 180° x COLLA "UV"
***1972/028**

inox	UV	∅ 28	€/u
s.s.			*o



40-50

PIE CON NIVELADOR x PEGAMENTO "UV"
BASÉ AVEC NIVELEUR x COLLAGE "UV"
BASE WITH LEVELER x "UV" GLUE
BASE CON LIVELLATORE x COLLA "UV"
***1978/028**

inox	UV	∅ 60	€/u
s.s.			*o

DIS-PLAY

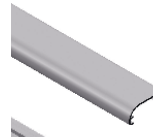

PERFIL TAPA
PROFIL COUVERTURE
COVER PROFILE
PROFILO COPERTINA
4020/101

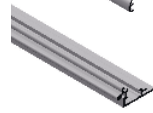

PERFIL BASE
PROFIL BASE
BASE PROFILE
PROFILO BASE
4021/100



MUELLE
RESSORT
SPRING
MOLLA
Se recomienda 4-5 u/m
4022/028

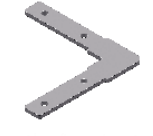

ESCUADRA ENSAMBLE
ÉQUERRE DE ASSEMBLAGE
ASSEMBLING CORNER BRACKET
STAFFA UNIONE D'ANGOLO
4023/034



TAPA ESQUINA
COUVERCLE DE COIN
CORNER COVER
COPERTINA ANGOLO
***4024/032**

PL. M	BRUTO	INOX SAT	CR. BRILLO	ZINCADO
ALL. M	BRUT	INOX SAT	CR. POLI	PL. ZNK
ALL. M	RAW	S. S. S.	BR. CHR	PL. ZNK PL.
ALL. NAT	GREZZO	INOX SAT	INOX SAT	CR. ILLC.
				ZINCATO
01	00	28	32	34
Al	5 m	32x14 mm		€/m
				o
Al	5 m	32x14 mm		€/m
				o
inox	∞ 4000			€/u
s.s.				o
				Fe €/u
				o
				plas €/u
				*o

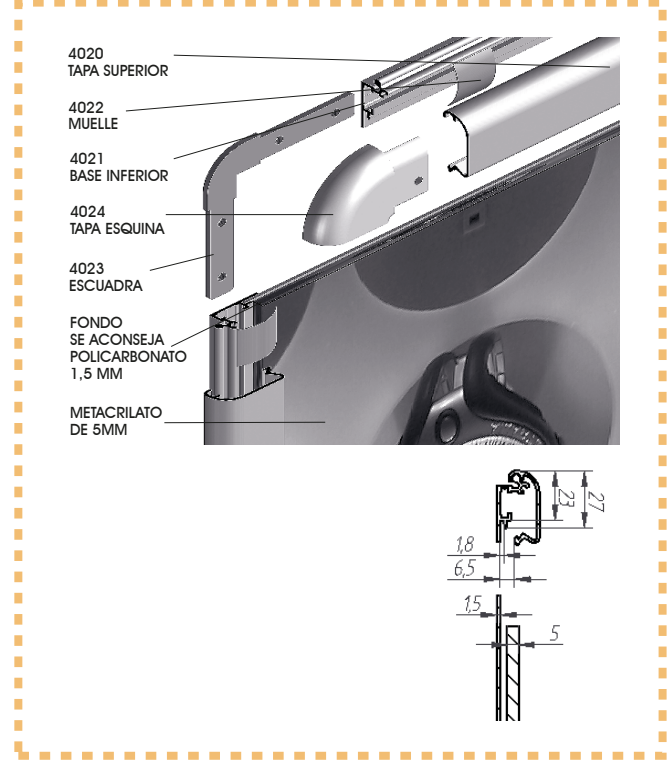

***CLICK** SISTEMA DE PERFILES DE ALUMINIO PARA TODO TIPO DE VITRINAS Y MOSTRADORES

Aluminum profile system for all types of showcases
Système de profilés en aluminium pour tous les types de vitrines
Sistema di profili di alluminio per vetrine

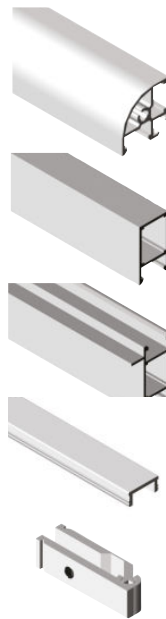
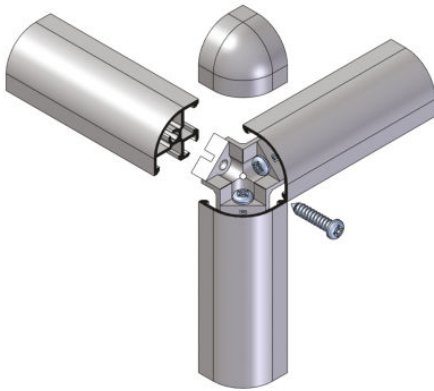

PERFIL QUADRANT
PERFIL QUADRANT
QUADRANT PROFILE
PROFILO QUADRANT
*868/1..

1 SALIDA
1 RAINURÉS
1 SLOT
1 CANALE
*858/1..

2 SALIDA+1 ALETA
2 RAINURÉS+1 SUPPORT
2 SLOTS +1 SUPPORT
2 CANALI + 1 APPOGGIO
*871/1..

PERFIL TAPABOCAS
PROFIL COUVERTURE
COVER PROFIL
PROFILO COPRI-CANALE
*961/1..

GRAPA ENSAMBLE
JOIN ASSEMBLAGE
ASSEMBLY JOINT
GRAPPA ASSEMBLAGGIO
*882/000

PL. BR ALU. BR ALU. BR ALL. LUC	BLANCO BLANC WHITE BIANCO	NEGRO NOIR BLACK NERO	PL. M ALL. M ALL. NAT	COLOR COULEUR COLOR COLORE
02	0B	0N	01	0P
Al	5 m	30x30	€/m	
*o	*o	*o	*o	*o
Al	5 m	35x20	€/m	
*o	*o	*o	*o	*o
Al	5 m	45x20	€/m	
*o	*o	*o	*o	*o
Al	5 m	14x6	€/m	
*o	*o	*o	*o	*o
Al	∞	858-859-871-871-866	€/m	
*o				

VIDRIO SUPERIOR
VERRE SUPERIEUR
UPPER GLASS
VETRO SUPERIORE

VIDRIOS FIJOS
VERRES FIXES
FIXED GLASSES
VETRI FISSILATERALI

MADERA
BOIS
WOOD
LEGNO

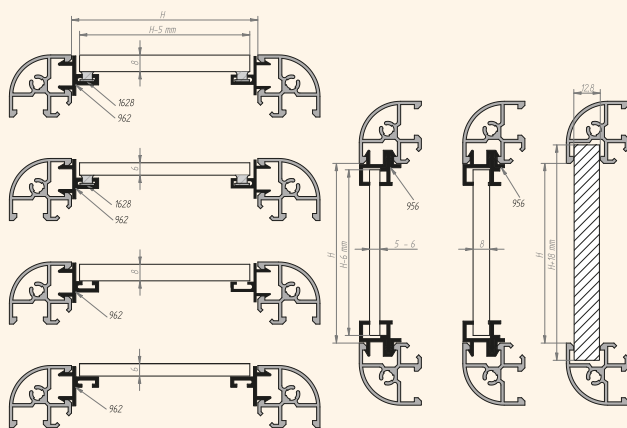

CR. BRILLO CHR. POLI BR. CHR. CR. LUC.	CR. MATE CHR. M M. CHR. CR. OPAC	CR. ORO CHR. DOR GOLD. C CR. ORO	BLANCO BLANC WHITE BIANCO	NEGRO NOIR BLACK NERO	COLOR COULEUR COLOR COLORE	BRUTO BRUT RAW GREZZO
32	31	33	0B	0N	0P	00

NUCLEO UNION
JOINT 90° 868
JOINT 90° 868
GIUNTO 90° 868
*898/000

TAPA SUPERIOR 868
EMBOIT SUPERIEURE
UPPER COVER 868
COPRITESTA SUPERIORE
*892/0..

TAPA PLÁSTICO
EMBOIT
END-CAP
COPRITESTA
*895/00N

SOPORTE ESTANTE
SUPPORT TABLETTE
SHELF SUPPORT
APPOGGIO RIPIANO
*928/04N

REFUERZO HIERRO
REINFORCEMENT EN FER 90°
REINFORCING IRON PIECE 90°
RINFORZO IN FERRO 90°
*943/034

SET BISAGRA CAZOLETA
CHARNIERE PIVOIEMENT
PIVOTING HINGE
CERNIERA CARDINE
1522/S32

BISAGRA PARED-VIDRIO
CHARNIERE MUR-VERRE
HINGE WALL-GLASS
CERNIERA PARETE-VERRO
1963/032

Al	∞	868	€/u			
						*o
Zn	∞	898	€/u			
						*o
plas	∞	868	€/u			
						*o
plas	∞	868-874	€/u			
						*o
Fe	€/u					
						*o
inox s.s.	4-6 mm	40x22	12 kg/2u			
						o
Cu	4-6 mm	25x20	2,5 kg/u			
						o

CORREDERA PLÁSTICO
COULISSE EN PLASTIQUE
PLASTIC SLIDING DOOR
SCORREVOLE IN PLASTICA
H. MAX.: 1,2 M

CORREDERA ALUMINIO
COULISSE EN ALUMINIUM
SLIDING DOOR IN ALUMINIUM
SCORREVOLE IN ALLUMINIO
H. MAX.: 2 M

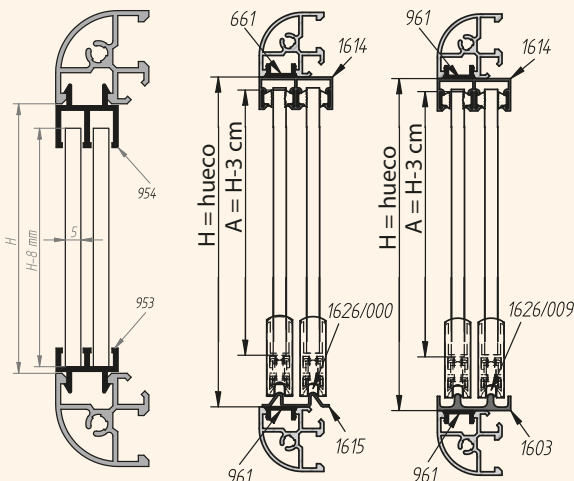

*CLICK

KITS

BLANCO PL. M	NEGRO	COLOR
BLANC ALLU. M	NOIR	COULEUR
WHITE ALLU. M	BLACK	COLOR
BIANCO ALL. NAT	NERO	COLORE
OB	O1	ON
		OP

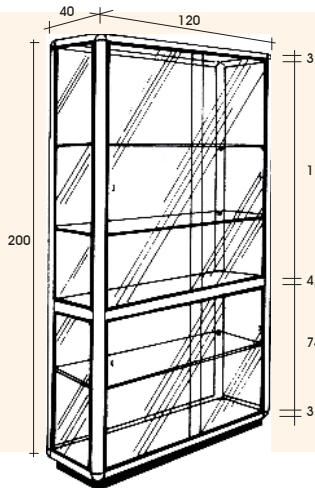

VITRINA 2 CUERPOS MEDIDAS: 120 x 200 x 40cm.
CORREDERAS PLÁSTICO. EL PRECIO INCLUYE SÓLO LA ESTRUCTURA DE ALUMINIO, JUNQUILLOS Y 2 CERRADURAS SERRETA. NO SE SUMINISTRAN CRISTALES Y MADERAS.

Vitrine 2 corps. Couissant en plastique. Le prix comprend la structure en aluminium, les profils en plastique et 2 serrures avec crémaillère. Nous ne fournissons pas de verre et de bois.

Showcase 2 bodies. Plastic sliding door. The price includes the aluminium structure, the plastic profiles and 2 ratchet locks. We don't supply glass and wood.

Vetrina 2 corpi. Scorrevoli in plastica. Il prezzo comprende la struttura di alluminio, i profili di plastica e 2 serrature cremagliera. Non forniamo vetri e legno.

3 *VT125/0.. *o *o *o

BLANCO PL. M	NEGRO	COLOR
BLANC ALLU. M	NOIR	COULEUR
WHITE ALLU. M	BLACK	COLOR
BIANCO ALL. NAT	NERO	COLORE
OB	O1	ON
		OP

KITS

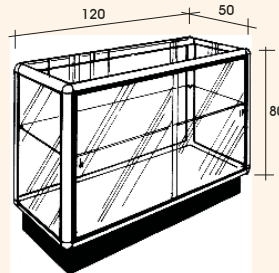

MOSTRADOR CLÁSICO MEDIDAS: 120 x 80 x 50cm
CORREDERAS PLÁSTICO + 1 CERRADURA SERRETA. EL PRECIO INCLUYE SÓLO LA ESTRUCTURA DE ALUMINIO Y LOS JUNQUILLOS. NO SE SUMINISTRAN CRISTALES Y MADERAS

Vitrine-comptoir classique. Couissant en plastique + 1 serrure avec crémaillère. Le prix comprend la structure en aluminium, les profils en plastique. Nous ne fournissons pas de verre et de bois.

Showcase-desk classic. Plastic sliding door + 1 ratchet lock. The price includes the aluminium structure and the plastic profiles. We don't supply glass and wood.

Vetrina-banco classica. Scorrevoli in plastica + 1 serratura cremagliera. Il prezzo comprende la struttura di alluminio e i profili di plastica. Non forniamo vetri e legno.

*MC123/0.. *o *o *o

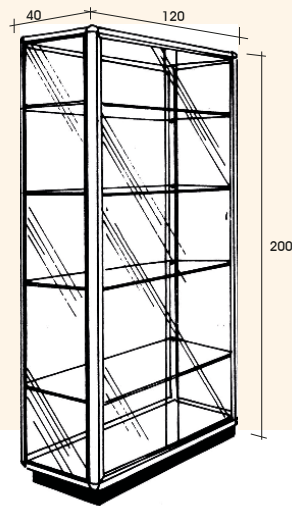

VITRINA 1 CUERPO MEDIDAS: 120 x 200 x 40cm.
CORREDERAS ALUMINIO. EL PRECIO INCLUYE SÓLO LA ESTRUCTURA DE ALUMINIO, JUNQUILLOS Y 1 CERRADURA SERRETA. NO SE SUMINISTRAN CRISTALES Y MADERAS.

Vitrine 1 corp. Couissant en aluminium. Le prix comprend la structure en aluminium, les profils en plastique et 1 serrure avec crémaillère. Nous ne fournissons pas de verre et de bois.

Showcase 1 body. Aluminium sliding door. The price includes the aluminium structure, the plastic profiles and 1 ratchet lock. We don't supply glass and wood.

Vetrina 1 corpo. Scorrevoli in alluminio. Il prezzo comprende la struttura di alluminio, i profili di plastica e 1 serratura cremagliera. Non forniamo vetri e legno.

*VT200/0.. *o *o *o

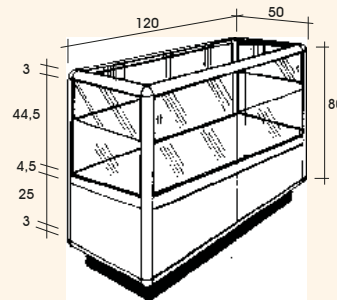

MOSTRADOR CON PARTE INFERIOR CERRADA PUERTAS CORREDERAS, 2 CERRADURAS SERRETA MEDIDAS: 120 x 80 x 50cm
EL PRECIO INCLUYE SÓLO LA ESTRUCTURA DE ALUMINIO. NO SE SUMINISTRAN CRISTALES Y MADERAS

Vitrine-comptoir classique avec rangement. Couissant en plastique + 2 serrures avec crémaillère. Le prix comprend la structure en aluminium, les profils en plastique. Nous ne fournissons pas de verre et de bois.

Showcase-desk classic with warehouse. Plastic sliding door + 2 ratchet locks. The price includes the aluminium structure and the plastic profiles. We don't supply glass and wood.

Vetrina-banco classica con magazzino. Scorrevoli in plastica + 2 serrature cremagliera. Il prezzo comprende la struttura di alluminio e i profili di plastica. Non forniamo vetri e legno.

*MA127/C.. *o *o *o

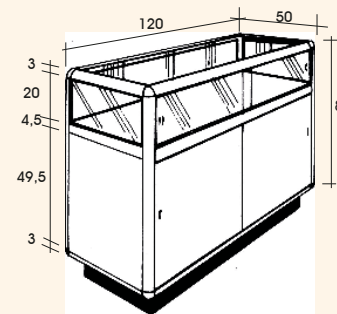

MOSTRADOR CON PARTE INFERIOR CERRADA PUERTAS CORREDERAS, 2 CERRADURAS SERRETA MEDIDAS: 80 x 120 x 50cm
EL PRECIO INCLUYE SÓLO LA ESTRUCTURA DE ALUMINIO. NO SE SUMINISTRAN CRISTALES Y MADERAS

Vitrine-comptoir classique avec rangement. Couissant en plastique + 2 serrures avec crémaillère. Le prix comprend la structure en aluminium, les profils en plastique. Nous ne fournissons pas de verre et de bois.

Showcase-desk classic with warehouse. Plastic sliding door + 2 ratchet locks. The price includes the aluminium structure and the plastic profiles. We don't supply glass and wood.

Vetrina-banco classica con magazzino. Scorrevoli in plastica + 2 serrature cremagliera. Il prezzo comprende la struttura di alluminio e i profili di plastica. Non forniamo vetri e legno.

*MA127/0.. *o *o *o

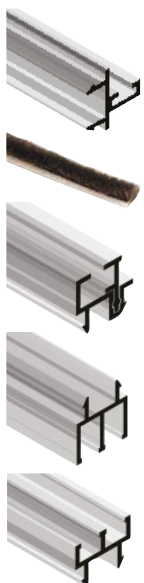

APOYO Y/O BATTIENTE
SUPPORT ET/OU BATTANT
SUPPORT AND/OR DOOR STOP
APPOGGIO E/O BATTENTE
*962/10N

FELPA
BROSSER
BRUSH
FELPA
1628/109

JUNQUILLO VIDRIO FIJO
PROFILE VERRE FIXE
FIXED GLASS PROFILE
PROFILO VETRO FISSO
*956/10N

CORREDERA SUPERIOR
COULISSE HAUTE
SLIDING DOOR UPPER TRACK
SCORREVOLE BINARIO ALTO
*954/10N

CORREDERA INFERIOR Y LATERAL
COULISSE BASSE ET LATÉRALE
SLIDING DOOR LOWER TRACK AND LATERAL
SCORREVOLE BINARIO BASSO E LATÉRALE
*953/10N

PL. M	ORO M	BLANCO	NEGRO	PLÁSTICO
ALLU. M	DORÉ M	BLANC	NOIR	PLASTIQUE
ALLU. M	GOLD M	WHITE	BLACK	PLASTIC
ALL. NAT	DOR. OP	BIANCO	NERO	PLASTICA
O1	O3	OB	ON	O9

plas 4 m 6-8 mm €/m

plas 325 m €/m

plas 4 m 5-6-8 mm €/m

plas 4 m 5 mm €/m

plas 4 m 5 mm €/m

***FACILPLUS**

BLANCO BLANC WHITE BIANCO	PL. M ALU. M ALU. M ALL. NAT	NEGRO NOIR BLACK NERO	BRUTO BRUT RAW GREZZO	COLOR COULEUR COLOR COLORE
OB	O1	ON	OO	OP

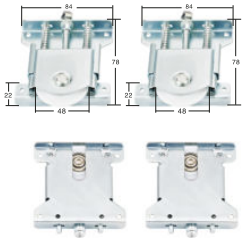

SET COJINETES SUPERIOR + BUFFER AUTOCIERRE SET GALETES HAUTES + AMORTISSEUR SET UPPER ROLLER + SELF-CLOSING SYSTEM SET CUSCINETTO + AMORTIZZATORE	Fe	∞ 1720	€/U
*1736/034			*o



CARRIL INFERIOR DOBLE
RAIL DOBLE INFERIEUR
LOWER DOUBLE RAIL
BINARIO DOPPIO INF.
*1724/1..

Al	5 m	62x6 mm	€/m
		37,25 mm	€/m



STOP INTERIOR CARRIL
STOP CHARLOT
STOP ROLLER
STOP CUSCINETTO
*1731/000

Fe	∞ 1724	€/U
		*o

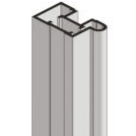

PERFIL LATERAL
PROFILE LATERAL DOOR
DOOR LATERAL PROFILE
PROFILO LATERAL PORTA
*1720/101

Al	Consultar	34x20 mm	€/m
		10 mm	€/m



FELPA ADHESIVA
BROSSER ADHESIF
ADHESIVE BRUSH
FELPA ADESIVA
*1732/100

plas	∞ 1720	75 m	€/m
			*o

***ARPLUS**
SISTEMA DE PUERTAS TIPO "CLASICO"

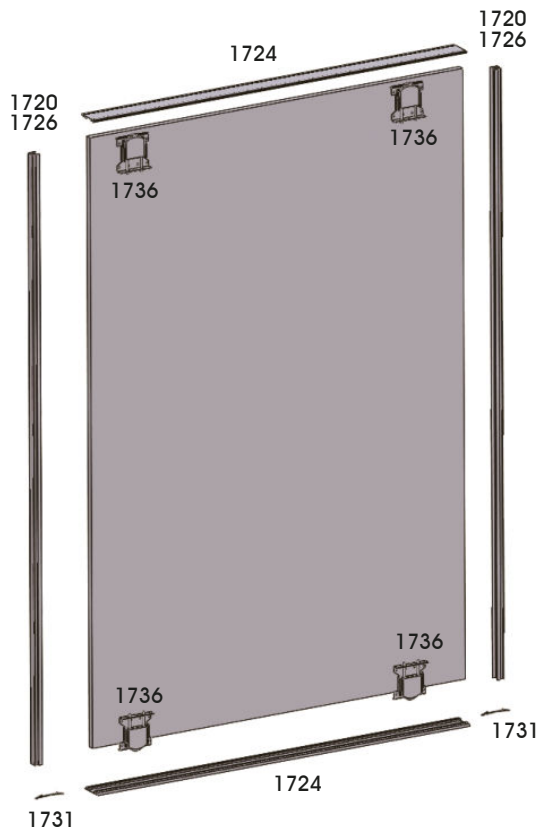
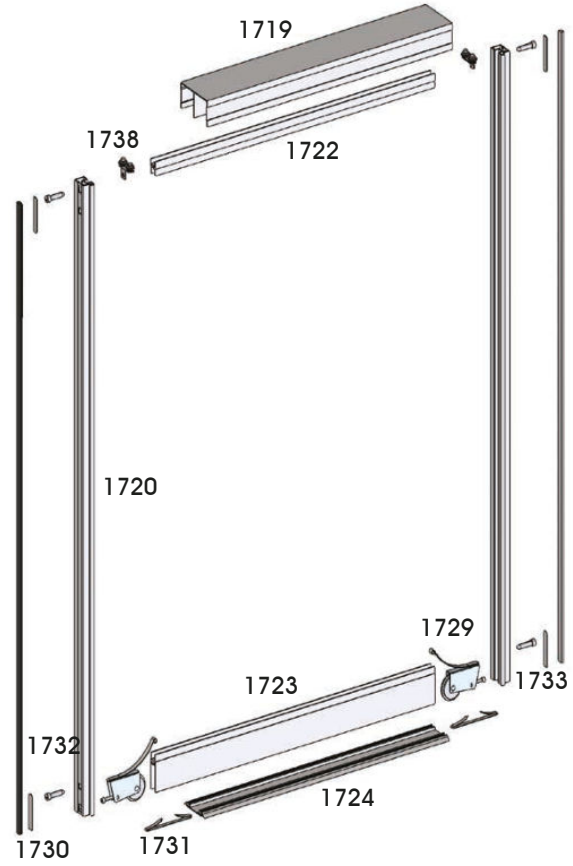

SISTEMA DE PUERTAS TIPO "JAPONESA"

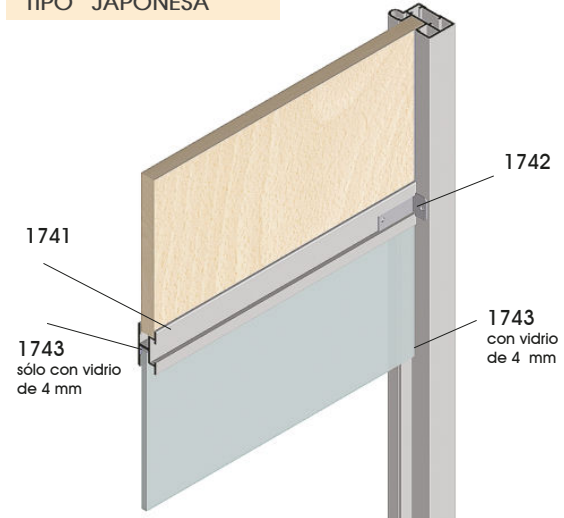

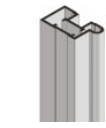

LATERAL PUERTA
PROFILE LATERAL DOOR
DOOR LATERAL PROFILE
PROFILO LATERAL PORTA
*1720/1..

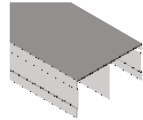

SUPERIOR DOBLE
COULISSE HAUTE BOBLE
UPPER DOUBLE TRACK
GUIDA SUPERIOR DOPPIA
*1719/1..



CASACA SUPERIOR
PROFILE DOOR HAUTE
UPPER DOOR PROFILE
PROFILO SUPERIORE PORTA
*1722/1..

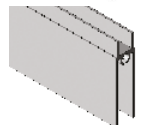

CASACA SUPERIOR
PROFILE DOOR HAUTE
UPPER DOOR PROFILE
PROFILO SUPERIORE PORTA
*1723/1..



CARRIL INFERIOR DOBLE
RAIL DOBLE INFÉRIEUR
LOWER DOUBLE RAIL
BINARIO DOPPIO INF.
*1724/1..



COJINETE SUPERIOR
GALET HAUTE
UPPER ROLLER
CUSCINETTO SCORREV.
*1738/009



COJINETE
GALET ACIER
METALLIC ROLLER
PATTINO METAL. SCORREV.
*1729/000



STOP INTERIOR CARRIL
STOP CHARLOT
STOP ROLLER
STOP CUSCINETTO
*1731/000



TORNILLO
VIS
SCREW
VITE
*1730/000



TAPÓN ADHESIVO
BOUCHON ADHESIF
HOLES ADHESIVE COVER
COPERTINA FORI ADESIVA
*1733/0..

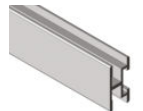

PERFIL PARA "JAPONESA"
PROFILE X PORTE "JAPANAIS"
"JAPANESE" DOOR PROFILE
PROFILO PORTA "GIAPPONESE"
*1741/1..



FELPA ADHESIVA
BROSSER ADHESIF
ADHESIVE BRUSH
FELPA ADESIVA
*1732/100



ENSAMBLE PARA "JAPONESA"
ASSEMBLAGE PORTE "JAPANAIS"
"JAPANESE" ASSEMBLY
FISSAGGIO "GIAPPONESE"
*1742/034



JUNQUILLO VETRO
PERFIL POUR VERRE
PROFILE FOR GLASS
PROFILO PER VETRO
*5060/109

BLANCO BLANC WHITE BIANCO	PL.M ALU.M ALL.NAT	ORO M DORÉ M GOLD M DOR.OP	NEGRO M NOIR BLACK NERO	BRUTO BRUT RAW GREZZO	COLOR COULEUR COLOR COLORE
OB	O1	O3	ON	OO	OP

Al	Consultar	34x20 mm	10 mm	€/m				
*o	*o		*o		*o			
Al	5 m	81x40 mm	37,25 mm	€/m				
*o	*o		*o		*o			
Al	5 m	22x11 mm	10 mm	€/m				
*o	*o		*o		*o			
Al	5 m	57x11 mm	10 mm	€/m				
*o	*o		*o		*o			
Al	5 m	62x6 mm	37,25 mm	€/m				
*o	*o		*o		*o			
Fe	∞ 1720			€/u				*o
Fe	20 kg/u	∞ 1723		€/u				*o
Fe	∞ 1724			€/u				*o
Fe	∞ 1720-1723-1722			€/u				*o
plas	∞ 1720			€/u				*o
		*o	*o		*o			*o
Al	5 m	26x14 mm	6-10 mm	€/m				
*o	*o		*o		*o			*o
plas	∞ 1720	75 m		€/m				
								*o
Fe	∞ 1720-1741			€/u				*o
								*o
plas	3 m	∞ 1741	4 mm	€/m				
								*o

KITS

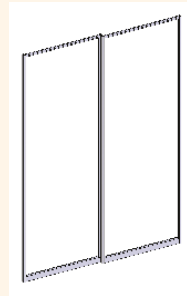

2 PUERTAS
2 PORTES
2 DOORS
2 PORTE

ANCHO HUECO Largeur Width Larghezza	ALTURA PUERTA CONSULTAR Hauteur max. consulter Height max. ask Altezza massima consultare
< 1,5 m	*o *o *o *o
1,51 <-> 2 m	*o *o *o *o
2,01 <-> 2,5 m	*o *o *o *o

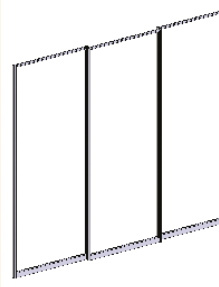

3 PUERTAS
3 PORTES
3 DOORS
3 PORTE

ANCHO HUECO Largeur Width Larghezza	ALTURA PUERTA CONSULTAR Hauteur max. consulter Height max. ask Altezza massima consultare
1,50 <-> 2 m	*o *o *o *o
2,01 <-> 2,5 m	*o *o *o *o
2,51 <-> 3 m	*o *o *o *o
3,01 <-> 3,5 m	*o *o *o *o

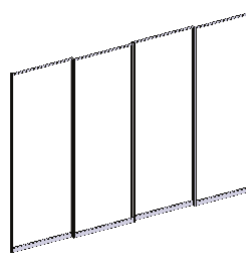

4 PUERTAS
4 PORTES
4 DOORS
4 PORTE

ANCHO HUECO Largeur Width Larghezza	ALTURA PUERTA CONSULTAR Hauteur max. consulter Height max. ask Altezza massima consultare
< 3 m	*o *o *o
3,01 <-> 3,5 m	*o *o *o
3,51 <-> 4 m	*o *o *o

PUERTA ALTA GAMA PANAMÁ MADERA

CORREDERA AUTOMÁTICA MAGNÉTICA DE MADERA

MOTOR ELECTROIMANES / Discreto, ultrasilencioso, sin mantenimiento.

al Aluminio anodizado	Ancho máximo 100 cm	40 kg/puerta	Testado 500.000 ciclos
P. Vidrio 8-10 mm	P. Enmarcadas 45 mm	P. Madera ≤45 mm	Puerta madera

INFORMACIÓN GENERAL

- Uso interior; doméstico, oficinas, hoteles, clínicas médicas, etc.
- Fácil instalación,
- Frecuencia de paso media/baja.

KITS

NEGRO
NOIR
BLACK
NERO
ON



KIT TÁCTIL

- 80-100 cm **4080/31N** ○
- 100-120 cm **4080/32N** ○
- 120-140 cm **4080/34N** ○



KIT SENSORES DE DISTANCIA

- 80-100 cm **4081/31N** ○
- 100-120 cm **4081/32N** ○
- 120-140 cm **4081/34N** ○



KIT INFRARROJO

- 80-100 cm **4082/31N** ○
- 100-120 cm **4082/32N** ○
- 120-140 cm **4082/34N** ○

Cada kit contiene dos piezas de el modo de apertura elegido.

SOBRE PEDIDO se puede conseguir puertas eléctricas telescópicas y/o sincronizadas.

MÚLTIPLES MODOS DE APERTURA PARA ELEGIR:



INTERRUPTOR DE SENSORES DE DISTANCIA

INTERRUPTOR DE INFRARROJO

INTERRUPTOR TÁCTIL

SOBRE PEDIDO
INTERRUPTOR DE HUELLAS DACTILARES

SOBRE PEDIDO
INTERRUPTOR FACE ID

MONTAJE DEL CARRIL



TESTADO 500.000 CICLOS



MONTAJE SISTEMA A PARED / A TECHO: (VIDRIO / VIDRIO ENMARCADO / MADERA)

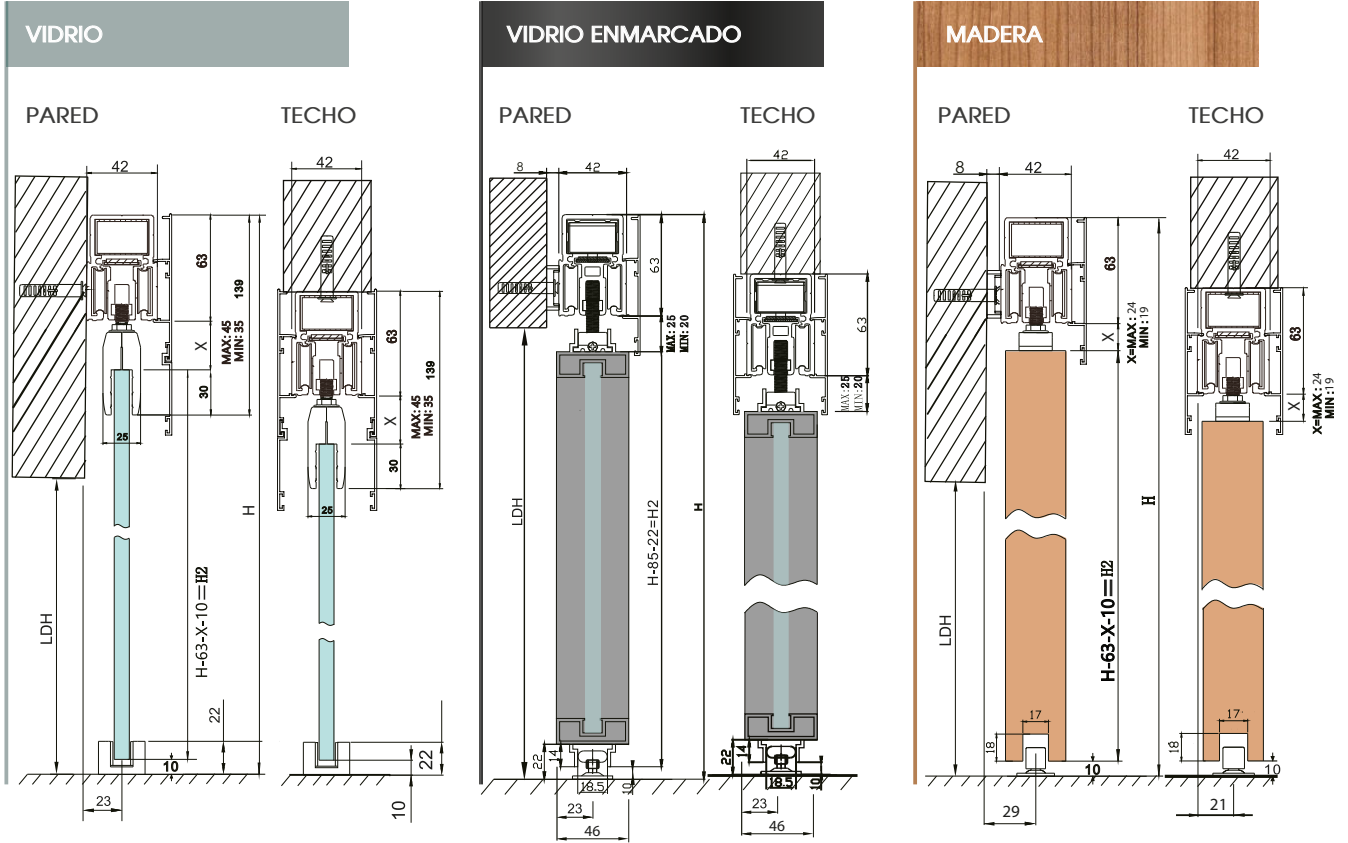

DISTINTOS MODOS DE APERTURA
Propuesta en la imagen:
interruptor táctil

* Escoger el carril magnético dependiendo del ancho de la puerta

Ancho de puerta	Ancho carril	Ref.
≤ 1000mm	793mm	4080/31N
1000-1200mm	1033mm	4080/32N
1200-1400mm	1240mm	4080/34N

CARACTERÍSTICAS DEL PRODUCTO

- Ajuste de altura 5mm
- Ruido ≤ 40dB
- Standby consumo ≤ 5w
- Consumo ≤ 100w
- Velocidad cierre 200-500 mm/sec
- Tensión 220v/110v
- Certificaciones:

CE EMC LVD FC

PUERTA PANAMÁ INVISIBLE MAGNÉTICA

CORREDERA INVISIBLE MAGNÉTICA DE MADERA

MOTOR ELECTROIMANES / Mecanismo totalmente oculto.

al Aluminio anodizado	 Ancho máximo 80-120 cm	 60 kg/puerta
 P. Enmarcadas 28-45 mm	P. Madera 28-45 mm	 Puerta madera

INFORMACIÓN GENERAL

- Adecuado para puertas correderas simples
- Adecuado para puertas para familias, hoteles, edificios de oficinas, etc.
- Doble sistema de cierre suave para

el funcionamiento del equilibrio de la puerta corredera.
- Posicionamiento manual de empujar y tirar en ambos lados para lograr el equilibrio.
- Fácil instalación, funcionamiento suave, larga vida útil

KITS

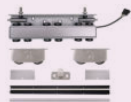

KIT ELÉCTRICO
80-120 cm
4077/000

BRUTO
BRUT
RAW
GREZZO
00

o

MÚLTIPLES MODOS DE APERTURA PARA ELEGIR:



INTERRUPTOR DE SENSORES DE DISTANCIA



INTERRUPTOR INFRARROJO



INTERRUPTOR TÁCTIL



SOBRE PEDIDO
INTERRUPTOR DE HUELLAS DACTILARES



SOBRE PEDIDO
INTERRUPTOR FACE ID



CONEXIÓN ELÉCTRICA

Sistema de rodillos deslizantes de accionamiento electromagnético

MEDIDAS PERFILES

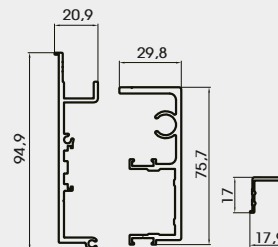

CONFIGURACIÓN ESTÁNDAR

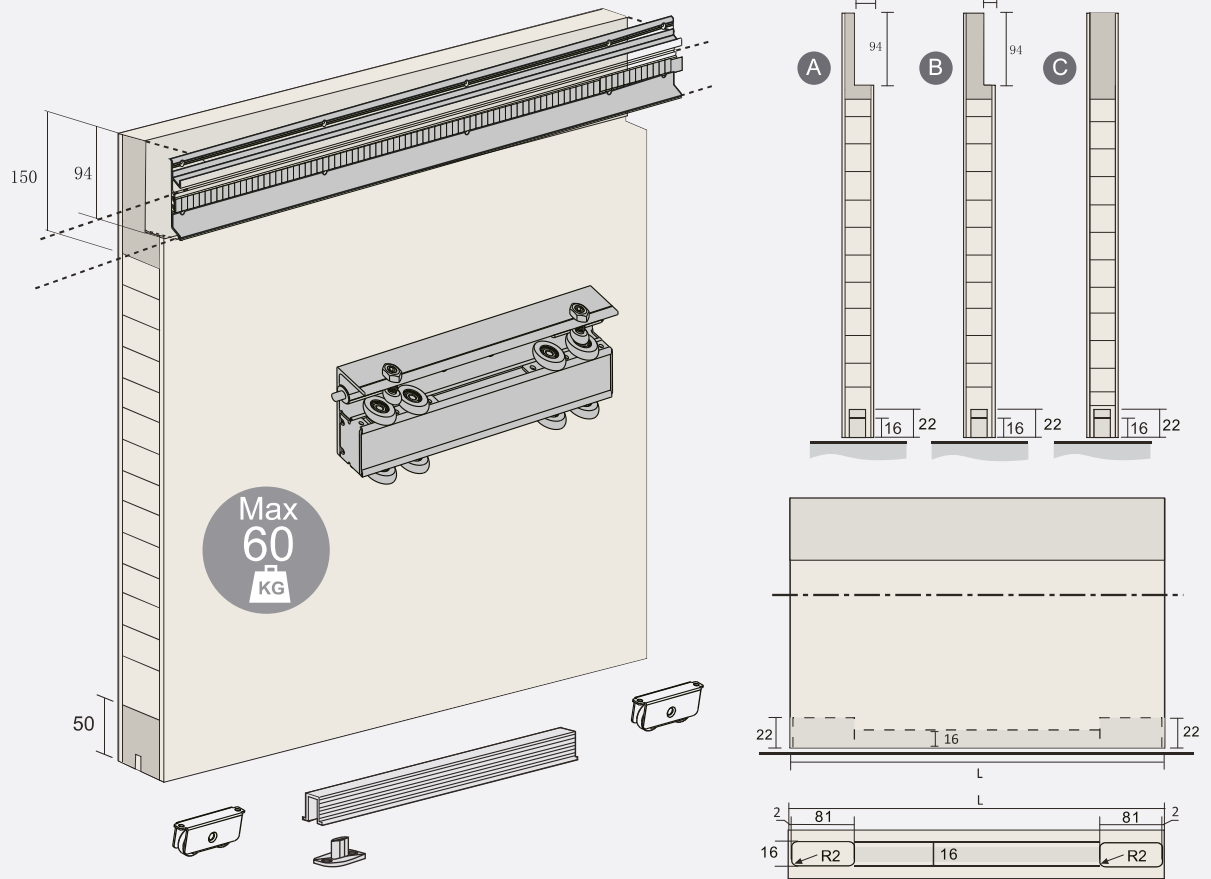

CONFIGURACIÓN ESTÁNDAR

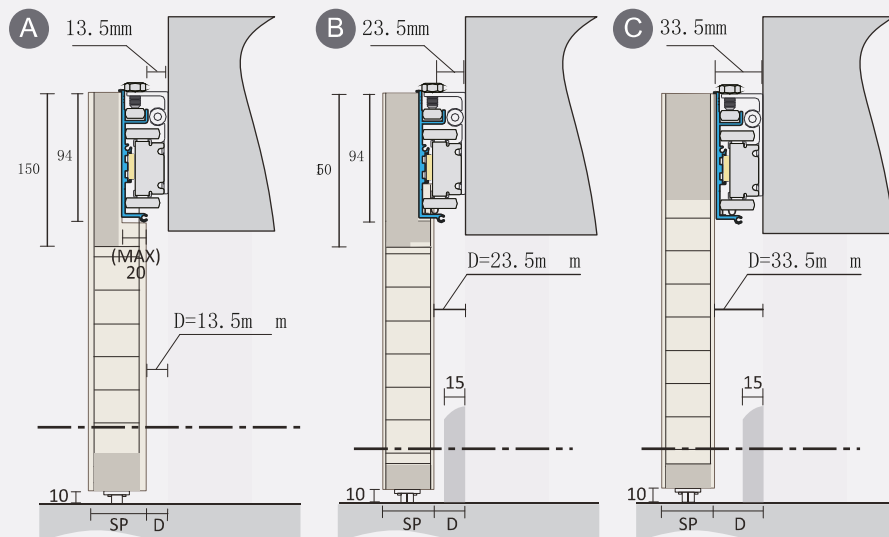

CANTÓN INVISIBLE MADERA (Manual)

AUTOCIERRE CON AMORTIGUADOR
SOFT CLOSING

al

Aluminio
anodizado



Ancho máximo
80-120 cm



60 kg/puerta



28 -45 mm

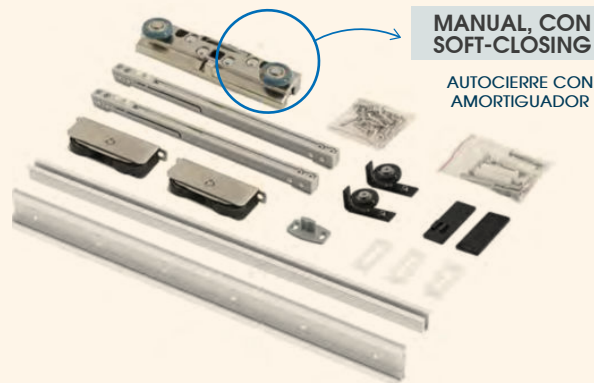

MANUAL, CON
SOFT-CLOSING

AUTOCIERRE CON
AMORTIGUADOR

REF.	ACABADOS	PRECIO
800-1200 mm 5165/000	00	kit manual o €/kit

MATERIALES Y ACABADOS

Carril deslizante: Aluminio, anodizado
Rodillo colgante: aleación de zinc, SN



CARACTERÍSTICAS PRINCIPALES

- Adecuado para puertas correderas simples
- Adecuado para puertas correderas para familias, hoteles, edificios de oficinas, etc.
- Doble sistema de cierre suave para el funcionamiento del equilibrio de la puerta corredera.
- Posicionamiento manual de empujar y tirar en ambos lados para lograr el equilibrio.
- Fácil instalación, funcionamiento suave, larga vida útil

MEDIDAS CARRO

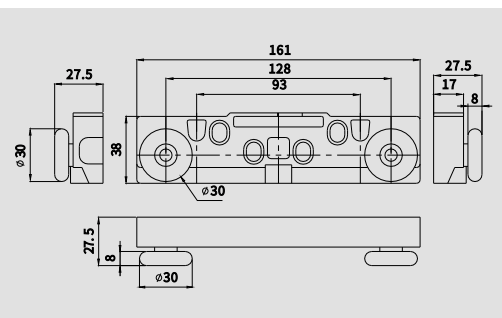

CONFIGURACIÓN ESTÁNDAR

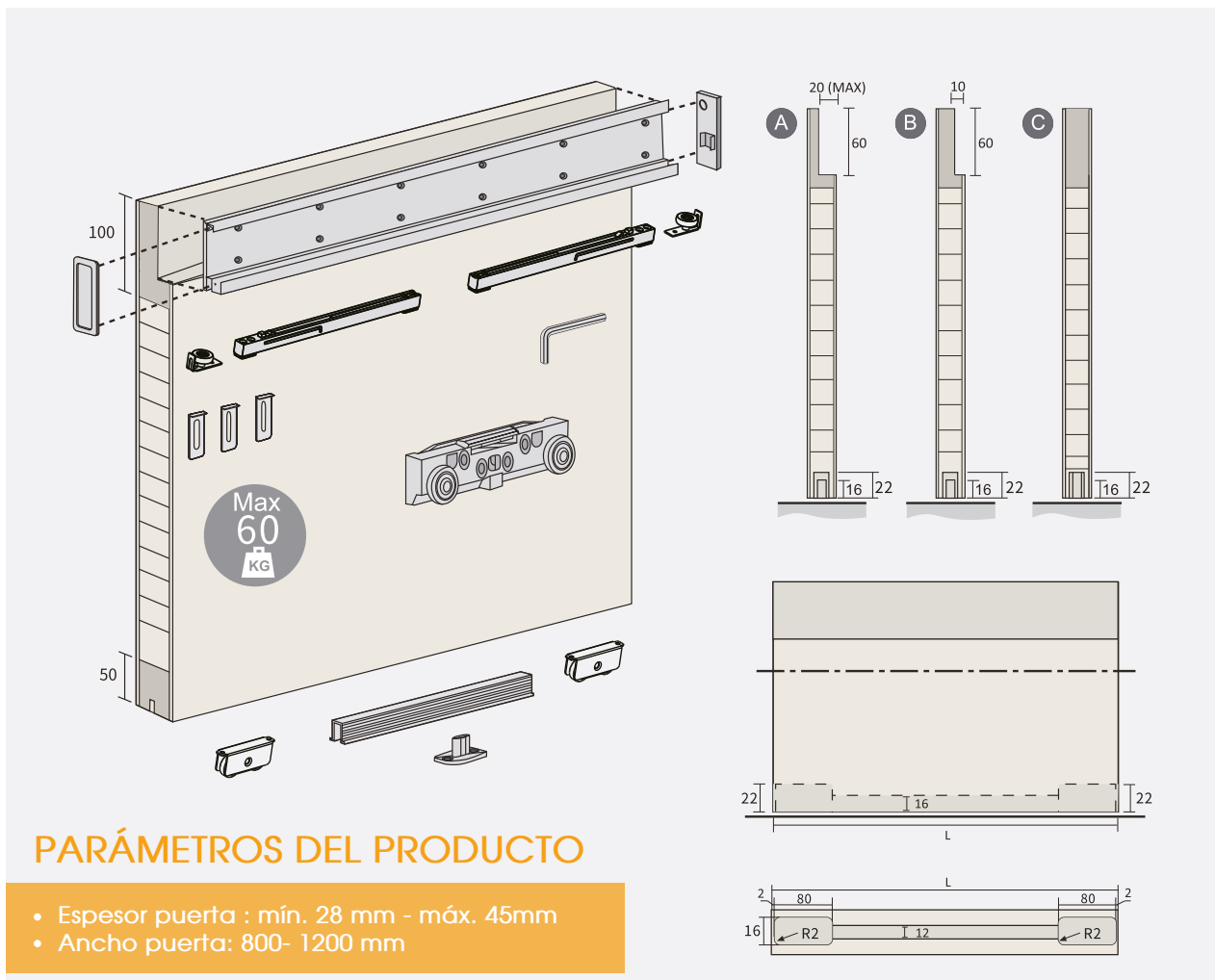

PARÁMETROS DEL PRODUCTO

- Espesor puerta : mín. 28 mm - máx. 45mm
- Ancho puerta: 800- 1200 mm

CONFIGURACIÓN ESTÁNDAR

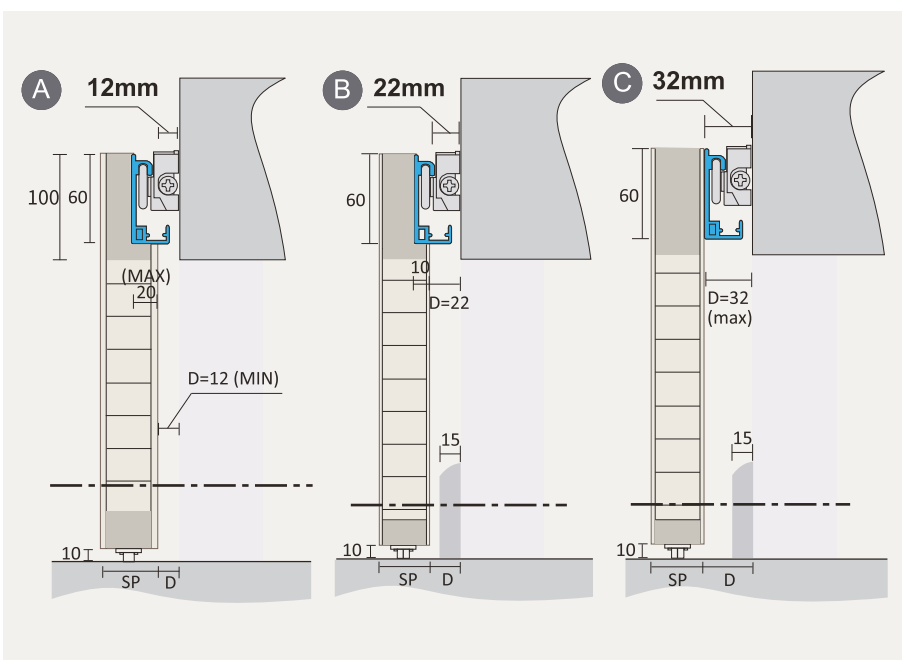

MEDIDAS PERFILES

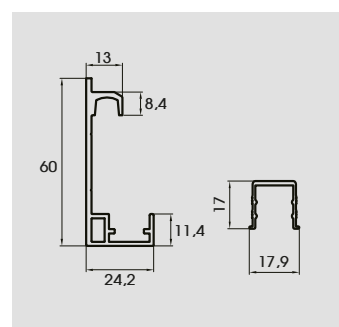

CANTÓN MADERA

PUERTA CORREDERA DE MADERA 80 KG

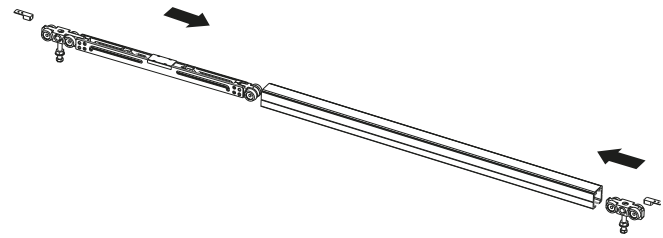

MONTAJE A TECHO O PARED
EL CARRIL 5111 ESTÁ MECANIZADO
CON UN TALADRO CADA 45 CM PARA
SER FIJADO DIRECTAMENTE A LA PARED
SIN NECESIDAD DE ESCUADRAS

- Montage au plafond ou au mur.
Le profilé supérieur 5111 est usiné avec des trous tous les 45 cm pour être fixé directement au mur sans avoir besoin de supports.
- Ceiling or wall mount.
The track 5111 is machined with holes every 45 cm to be fixed directly to the wall without the need for brackets
- Montaggio a soffitto o a muro.
La guida superiore 5111 è meccanizzata con fori ogni 45 cm per essere fissata alla parete senza necessità di supporti

SECCIÓN PARA
PUERTAS DE MADERA

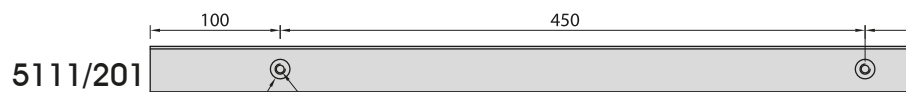
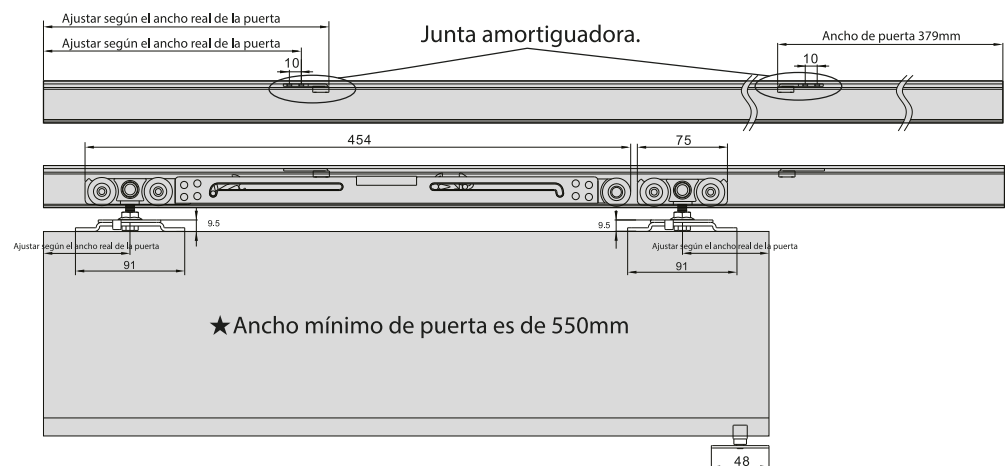
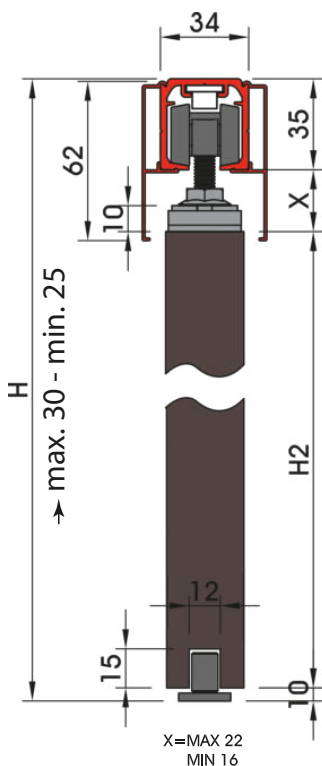

Agujero exterior Ø15mm. Agujero interior Ø6mm avellanado.



Agujero exterior Ø15mm. Agujero interior Ø6mm avellanado.

COMPONENTES



CARRIL
COULISSE HAUTE
UPPER TRACK
GUIDA SUPERIORE
5111/201 2 m
5111/301 3 m

CR. BRILLO CR. POLI BR. CR. CR. ILLC.	PL. M ALU. M ALL. NAT.	BRUTO BRUT RAW GREZZO	PLÁSTICO PLASTIQUE PLASTIC PLASTICA
32	01	00	09
Al	2/3 m		€/u

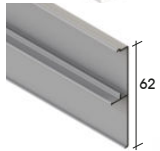

PERFIL TAPA CARRIL
PROFIL COUVERTURE COULISSE
TRACK COVER PROFIL
PROFILO COPERTINA GUIDA
5116/201 2 m
5116/301 3 m

Al	2 m	∅ 5111	€/u
----	-----	--------	-----



SET PINZA MADERA
PINCE POUR BOIS
CLAMP FOR WOOD
PINZA PER LEGNO
1 COJINETE + BUFFER AUTOCIERRE / 1 COJINETE SIN BUFER
2 TOPES AUTOCIERRE PINZAS / 2 ANCLAKES PUERTAS MADERA / 1 GUÍA INFERIOR
5115/001 CON BUFFER

Al	2 m	∅ 5116	€/u
----	-----	--------	-----

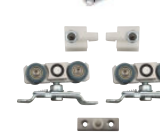

KIT FRENO (STOP) + GUÍA SUELO
KIT ARRÊT + GUIDE AU SOL
KIT STOP + FLOOR GUIDE
KIT STOP + GUIDA A PAVIMENTO
5122/012

Al	∅ 5116	€/u
----	--------	-----



TAPA LATERAL DE CARRIL
COUVERTURE LATÉRALE DU RAIL
TOP RAIL SIDE COVER
COPERTURA LATÉRALE SUPERIORE
5117/001 SET 2U.

Al	∅ 5116	€/u
----	--------	-----



UNERO DOBLE ADHESIVO
POIGNÉE DOUBLE ADHÉSIVE
DOUBLE ADHESIVE PULL
POMO DOPPIO ADHESIVO
4207/0..
4207/0..

Al	∅ 60	€/u
----	------	-----



GALGA MONTAJE UNEROS
GABARIT DE MONTAGE
INSTALLATION TOOL
SAGOMA AIUTO MONTAGGIO
4209/000

Al	€/u
----	-----



PERFIL TAPA CARRIL
PROFIL COUVERTURE
TRACK COVER PROFIL
PROFILO COPERTINA GUIDA
5112/201 2 m
5112/301 3 m

Al	2/3 m	∅ 5111	€/u
----	-------	--------	-----



TAPA LATERAL DE CARRIL
COUVERTURE LATÉRALE DU PROFIL
TOP RAIL SIDE COVER
COPERTURA LATÉRALE SUPERIORE
5113/001

Al	∅ 5112	€/u
----	--------	-----

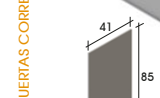

SET PINZA PORTAVIDRIO
PINCE POUR VERRE
CLAMP FOR GLASS
PINZA PER VETRO
1 COJINETE + BUFFER AUTOCIERRE / 1 COJINETE SIN BUFER
2 TOPES AUTOCIERRE PINZAS / 2 PINZAS DE ALUMINIO / 1 GUÍA INFERIOR
5110/001

Al	Fe	8-10 mm	€/u
----	----	---------	-----

80 kg/set

PARA PUERTAS CORREDERAS DE VIDRIO

KITS

PLATA MATE ALU. MAT ALL. NATURALE 01



5120/E21 2 m
5120/E31 3 m

KIT PUERTA CORREDERA PARA MADERA
EMPOTRABLE EN EL TECHO
KIT PORTE COUSSANTE BOIS AU PLAFOND
KIT SLIDING DOOR RECESSED IN THE CEILING
KIT PORTA SCORREVOLE INCASSATA NEL SOFFITTO
5111/201-5111/301 1 u. carril
5115/001 2 u. set pinzas para madera
4207/001 1 u. uñero

5121/P21 2 m
5121/P31 3 m

KIT PUERTA CORREDERA PARA MADERA A PARED
KIT DE PORTE COUSSANTE BOIS AU MUR
KIT SLIDING DOOR FIXED TO THE WALL
KIT PORTA SCORREVOLE FISSATA A PARETE
5111/201 1 u. carril
5116/201 1 u. tapa carril
5117/001 1 u. tapas laterales carril
5115/001 2 u. set pinzas para madera
4207/001 1 u. uñero

NOVEDAD

PERFIL PARA EMPOTRAR EN FALSOS TECHOS

BLANCO BLANC WHITE BIANCO	NEGRO NOIR BLACK NERO	BRUTO BRUT RAW GREZZO	COLOR COULEUR COLOR COLORE
0B	0N	00	0P

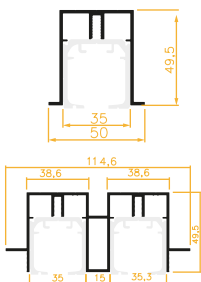

PERFIL PARA EMPOTRAR A TECHO
PROFIL POUR MONTAGE AU PLAFOND
PROFILE FOR CEILING MOUNTING
PROFILO PER MONTAGGIO A SOFFITTO

1 CARRIL/1 RAIL /1 BINARI
5450/10. 1M
2 CARRIL/2 RAIL /2 BINARI
5451/10. 1M

Al	2M 3M 4M	€/m
----	----------	-----

REF. 5451 OPCIÓN ALETA NO VISTA

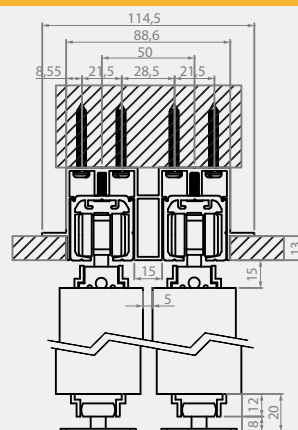

REF. 5450 OPCIÓN ALETA VISTA

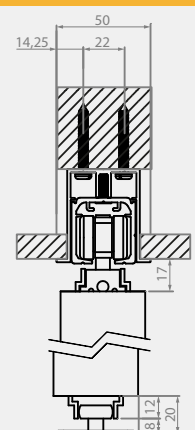

Lorem ip

CANTÓN TELEX MADERA 2

PUERTA CORREDERA TELESCÓPICA 2 PUERTAS

SISTEMA SINCRONIZADO DE 2 PUERTAS DE MADERA

al	Aluminio anodizado		Ancho máximo 68-120 cm
	60 kg/puerta		
	30 -45 mm		

REF.	ACABADOS	PRECIO
TELEX 2 Sin fijo 5160/000 <small>* Referencia por especificar</small>	00 	kit telex 2 o €/kit



CARACTERÍSTICAS DE APLICACIÓN DEL PRODUCTO

Número del producto	Producto	Especificaciones/tipos de puertas aplicables					
		Acabado	Peso puerta (kg)	Altura puerta (mm)	Ancho puerta (mm)	Espesor (mm)	Aplicación
5160/000	CANTÓN TELEX 2 MADERA	 Negro Otros (sobre pedido):  Gris	60	FH-78 (Ver plano)	680-1200	30-45	Puerta de madera

CARACTERÍSTICAS

- Sistema de puertas correderas sincronizadas telescópicas para tres puertas.
- Puertas correderas interiores adecuadas para familias, hoteles, edificios de oficinas, etc.
- Ahorro de espacio, buena decoración.

MATERIALES Y ACABADOS

- Carril: Aluminio, anodizado
- Cojinete: aleación de zinc, SN
- Soporte: Hierro, SN

ESQUEMA Y MEDIDAS DE MONTAJE

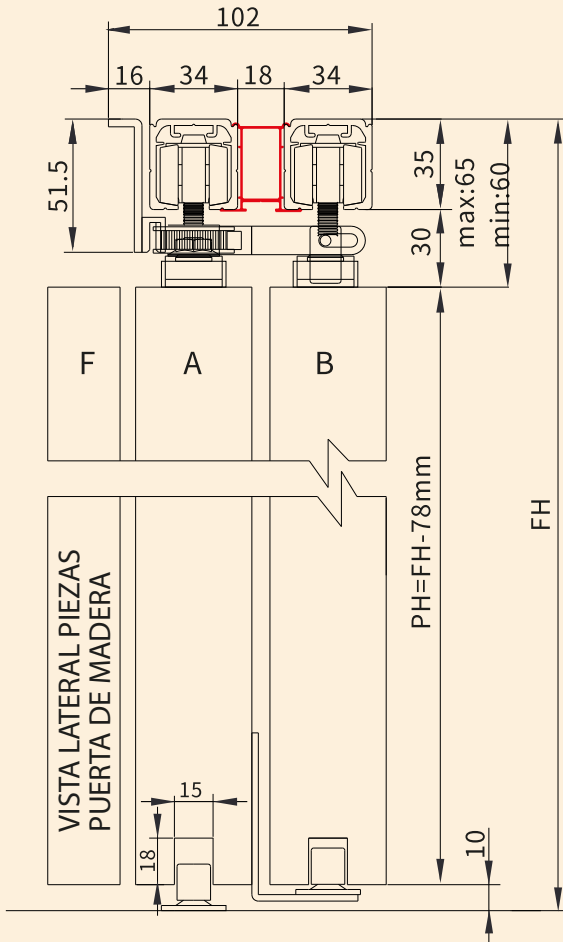

MEDIDAS ACCESORIOS

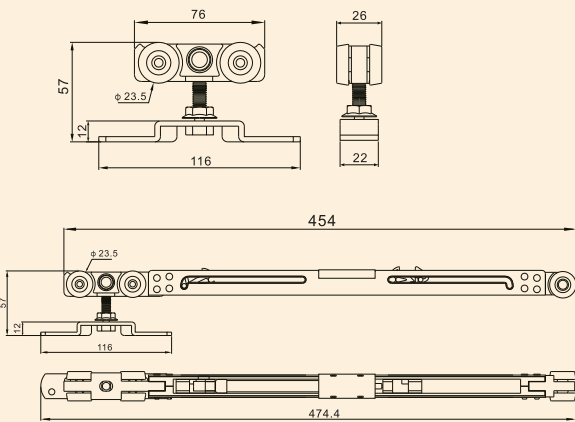

BLANCO BLANC WHITE BIANCO	NEGRO NOIR BLACK NERO	BRUTO BRUT RAW GREZZO	COLOR COULEUR COLOR COLORE
OB	ON	00	OP

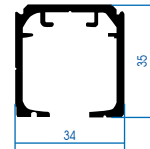

CARRIL SUPERIOR
RAIL EN ALUMINIUM
ALUMINIUM RAIL
BINARIO IN ALLUMINIO
5111/30. 3M

Al	3 m	€/u
----	-----	-----

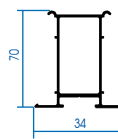

PERFIL DE PARTIÇÃO
PROFIL DE PARTITION
PARTITION PROFILE
PROFILO DELLA PARTIZIONE
5128/20N 2M
5128/30N 3M

Al	2 m	€/u
----	-----	-----

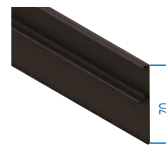

TAPA DE CARRIL SUPERIOR
COUVERTURE DE RAIL
SUPERIEURE
TOP RAIL COVER
COPERTURA SUPERIORE DEL
BINARIO
5210/40. 4M

Al	4 m	€/u
----	-----	-----



SOPORTE PANEL FIJO
SUPPORT DE PANNEAU FIXE
FIXED PANEL SUPPORT
SUPPORTO PANNELLO FISSO
5162/000

Al	4 m	€/u
----	-----	-----

INOX INOX P.S.S. INOX	BR POU LUC	PL.M ALU.M ALL.NAT
22		01



UÑERO DOBLE ADHESIVO
POIGNÉE DOUBLE ADHESIVE
DOUBLE ADHESIVE PULL
POMO DOPPIO ADHESIVO
4207/0..
4207/0..

Ø 60		€/u
------	--	-----

Al		€/u
INOX		€/u
S.S.		€/u



HUECO PUERTA
1883 - 3578

CANTÓN TELEX MADERA 3

PUERTA CORREDERA TELESCÓPICA 3 PUERTAS

SISTEMA SINCRONIZADO DE 3 PUERTAS DE MADERA

al Aluminio anodizado  Ancho máximo 68-120 cm

 60 kg/puerta

 30 -45 mm



REF.	ACABADOS	PRECIO
TELEX 2 Sin fijo 5161/000 <small>* Referencia por especificar</small>	00 	kit telex 2 o €/kit

CARACTERÍSTICAS DE APLICACIÓN DEL PRODUCTO

Número del producto	Producto	Especificaciones/tipos de puertas aplicables					
		Acabado	Peso puerta (kg)	Altura puerta (mm)	Ancho puerta (mm)	Espesor (mm)	Aplicación
5161/000	CANTÓN TELEX 3 MADERA	 Negro  Gris (sobre pedido)	60	FH-78 (Ver plano)	680-1200	30-45	Puerta de madera

CARACTERÍSTICAS

- Sistema de puertas correderas sincronizadas telescópicas para tres puertas.
- Puertas correderas interiores adecuadas para familias, hoteles, edificios de oficinas, etc.
- Ahorro de espacio, buena decoración.



MATERIALES Y ACABADOS

- Carril: Aluminio, anodizado
- Cojinete: aleación de zinc, SN
- Soporte: Hierro, SN

ESQUEMA Y MEDIDAS DE MONTAJE

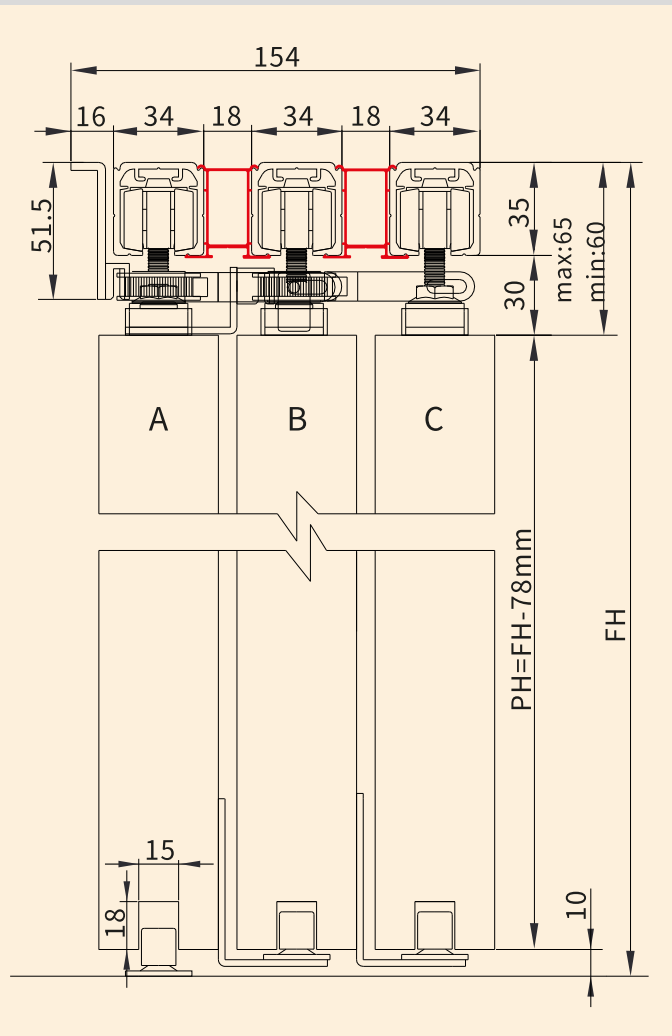

BLANCO BLANC WHITE BIANCO	NEGRO NOIR BLACK NERO	BRUTO BRUT RAW GREZZO	COLOR COULEUR COLOR COLORE								
OB	ON	00	0P								
<p>5111/40. 4M</p>											
<p>5128/20N 2M 5128/30N 3M 5128/40N 4M</p>											
<p>5210/40. 4M</p>											
<p>5162/40.</p>											
<p>4207/0.. 4207/0..</p>											
<table border="1"> <thead> <tr> <th>INOX NOX P.S.S. NOX LUC</th> <th>BR POLI ALU.M ALU.M ALL.NAT</th> <th>22</th> <th>01</th> </tr> </thead> <tbody> <tr> <td colspan="4"> <p>HUECO PUERTA 2272 - 4762</p> </td> </tr> </tbody> </table>				INOX NOX P.S.S. NOX LUC	BR POLI ALU.M ALU.M ALL.NAT	22	01	<p>HUECO PUERTA 2272 - 4762</p>			
INOX NOX P.S.S. NOX LUC	BR POLI ALU.M ALU.M ALL.NAT	22	01								
<p>HUECO PUERTA 2272 - 4762</p>											

MEDIDAS ACCESORIOS

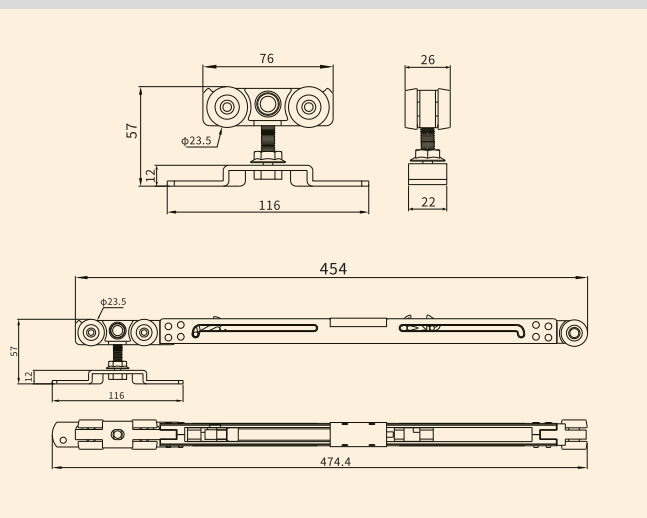

HUECO PUERTA
2272 - 4762

LIMA

HIERRO LACADO EN NEGRO

- HASTA 90 KG POR PUERTA
- GROSOR PUERTA DE 33-43 MM
- SOLO MONTAJE A PARED
- SE VENDE EN KIT POR PUERTAS DE 2 m (NO RECORTABLE)

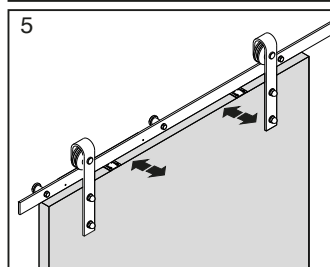
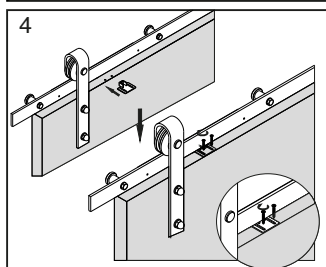
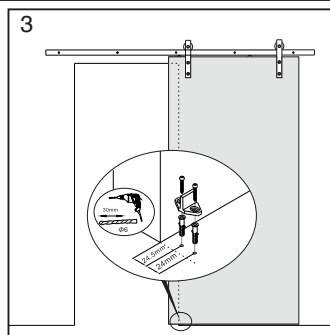
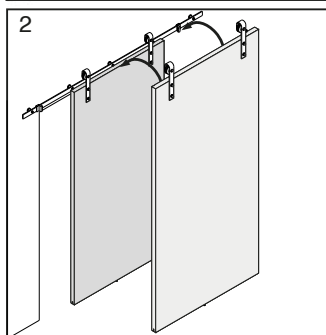
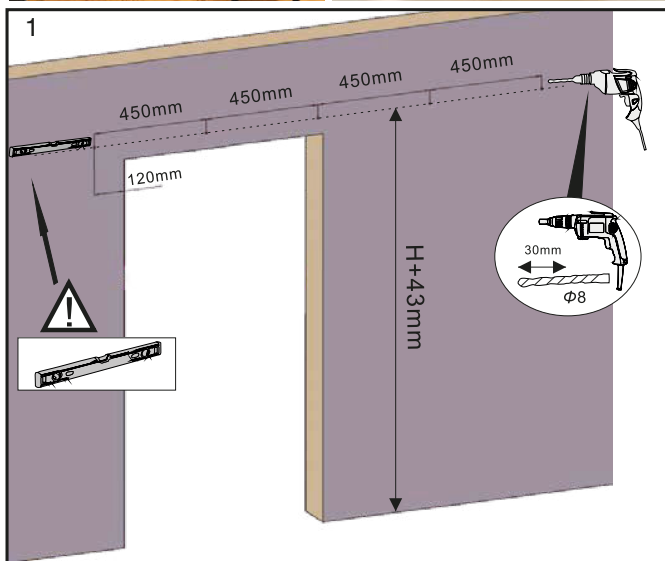

KITS

KIT PUERTA CORREDERA MONTAJE A PARED
KIT DE PORTE COULISSANTE FIXÉ AU MUR
SLIDING DOOR SET WALL MOUNTED
SET PORTA SCORREVOLE MONTATA A PARETE
5390/20N

€/u

- 1 u. **CARRIL ACERO**
COULISSE HAUTE - UPPER TRACK - GUIDA SUPERIORE
- 2 u. **COJINETES**
CHARLOT - ROLLER - CUSCINETTO
- 2 u. **STOP**
STOP CHARLOT - STOP ROLLER - STOP CUSCINETTO
- 5 u. **CONEXIÓN TUBO-PARED**
FIXATION TUBE-MUR - CONNEXION TUBE-WALL - CONNESSIONE TUBO-PARETE
- 1 u. **GUÍA INFERIOR**
GUIDAGE AU SOL - FLOOR GUIDE - GUIDA A PAVIMENTO
- 2 u. **PIEZAS ANTI-DESCARRILAMIENTO**
ÉPINGLE DE SÛREITÉ - SAFETY PIN - PERNO DI SICUREZZA
- 2 u. **AMORTIGUADOR CON RETENCIÓN**
AMORTISSEURS - DUMPERS SELF-CLOSING - AMORTIZZATORE

ATENCIÓN - ATTENTION - ATTENZIONE

- El carril no se puede cortar al estar mecanizado por los buffer amortiguadores
- Le rail ne peut pas être coupé lorsqu'il est usiné par les amortisseurs
- The rail can not be cut because machined for the dumpers selfclosing
- la guida non può essere tagliata perché meccanizzata per il fissaggio degli ammortizzatori

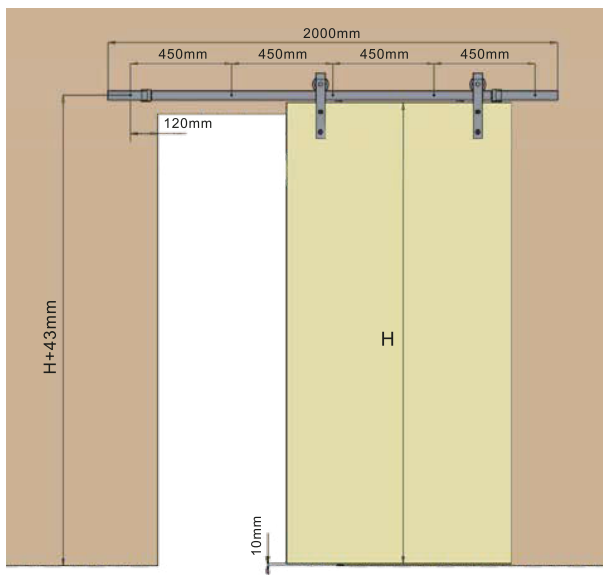

MATEK

SOLO A PARED: KIT 2 Mts. / KIT 3 Mts.



COJINETE
CHARLOT
ROLLER
CUSCINETTO
5363/028 plano

TUBO-CARRIL
TUBE-COULISSE
TUBE-TRACK
TUBO-GUIDA
4350/328 3 m
4350/228 2 m

REMATE FINAL CARRIL
BOUCHON COULISSE
END-CAP TRACK
COPRITESTA TUBO
236/028

GUÍA SUELO
GUIDAGE AU SOL
FLOOR GUIDE
GUIDA A PAVIMENTO
5364/028

STOP COJINETE
STOP CHARLOT
STOP ROLLER
STOP CUSCINETTO
5356/028 DERECHA
droite/right/destra
5357/028 IZQUIERDA
gauche/left/sinistra

ANCLAJE CARRIL-PARED
FIXATION MUR-COULISSE
CONNEXION WALL-TRACK
CONNESSIONE PARETE-GUIDA
4355/028

CONEXIÓN TUBO-PARED
FIXATION TUBE-MUR
CONNEXION TUBE-WALL
CONNESSIONE TUBO-PARETE
4353/028

UÑERO DOBLE ADHESIVO
POIGNÉE DOUBLE ADHESIVE
DOUBLE ADHESIVE PULL
POMO DOPPIO ADHESIVO
4207/0..

PLÁSTICO PLASTIQUE PLASTIC PLÁSTICA	INOX S.S.S.	SAT SAT	ZINCADO PL. ZNK ZINCO PL. ZINCATO		
09	28	34			
inox s.s.	L	2/3 m	Ø25x2,5	€/u	
Ø 25				€/u	
inox s.s.	Ø 25			€/u	
inox s.s.	Ø 25			€/u	
inox s.s.	Ø 25			€/u	
inox s.s.	Ø 60			€/u	

SET



5365/228 2 m

KIT PUERTA CORREDERA DE MADERA
KIT PORTE COULISSANTE EN BOIS
WOODEN SLIDING DOOR KIT
KIT PORTA SCORREVOLE IN LEGNO

4350/228 1 u. tubo carril
236/009 2 u. tapas finales
4353/028 4 u. conexión tubo-pared
5356/028 1 u. stop cojinete derecho
5357/028 1 u. stop cojinete izquierdo
5363/028 2 u. cojinetes
5364/028 1 u. guiador suelo
4207/028 1 u. uñero doble adhesivo

5365/328 3 m

KIT PUERTA CORREDERA DE MADERA
KIT PORTE COULISSANTE EN BOIS
WOODEN SLIDING DOOR KIT
KIT PORTA SCORREVOLE IN LEGNO

4350/328 1 u. tubo carril
236/009 2 u. tapas finales
4353/028 6 u. conexión tubo-pared
5356/028 1 u. stop cojinete derecho
5357/028 1 u. stop cojinete izquierdo
5363/028 2 u. cojinetes
5364/028 1 u. guiador suelo
4207/028 1 u. uñero doble adhesivo

MONTAJE A PARED

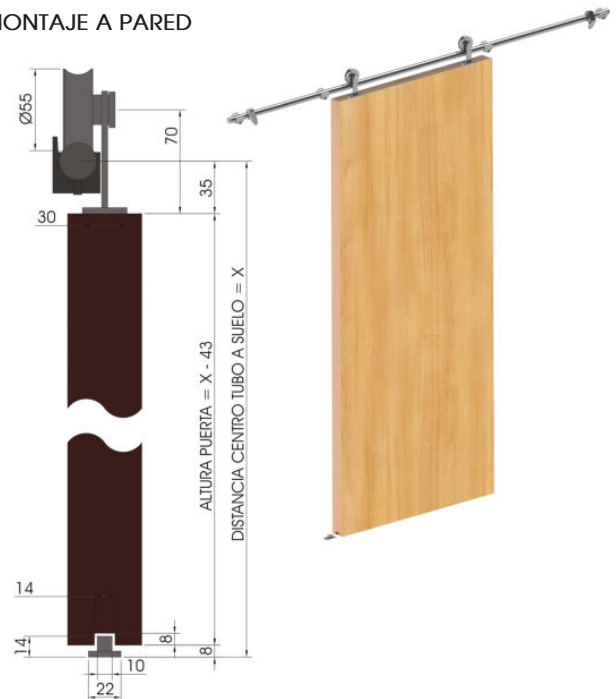

INOX SAT
INOX SAT
S.S.S.
INOX SAT
28

€/u

€/u

FH-9 / BISAGRA HIDRÁULICA OCULTA

REGULACIÓN 2D / PARA RETENCIÓN 90° UTILIZAR SH1 (REF. 5263 y 5264)

Aluminio aeronáutico / INOX 304	30,60 o 80 kg/ puerta	Vida útil: 200.000 ciclos	Con mecanización
Mínimo 42 mm	Ancho de 800 a 1000 mm	Puerta madera	

INFORMACIÓN GENERAL

- Ajuste 2D ± 2,5 mm
- Vida útil 200.000 ciclos
- Suave y silencioso
- Potente fuerza de cierre
- Diseño minimalista
- BISAGRA OCULTA
- ANTIATRAPAMIENTO / ANTIPELLIZCO
- ANTI PORTAZOS / ANTI CORRIENTES

KITS

NEGRO NOIR BLACK NERO ON

BISAGRA VACÍA

BISAGRA HIDRÁULICA

SET 2 BISAGRAS 30KG

30 KG

5250/LON Golpe Final

5250/OON Cierre Progresivo

€/Set

○

○

BISAGRA VACÍA

BISAGRA HIDRÁULICA

SET 2 BISAGRAS 60KG

30 KG

5251/LON Golpe Final

5251/OON Cierre Progresivo

€/Set

○

○

BISAGRA VACÍA

BISAGRAS HIDRÁULICAS (X2)

SET 3 BISAGRAS 80KG

30 KG

5252/LON Golpe Final

5252/OON Cierre Progresivo

€/Set

○

○

BISAGRA VACÍA

BISAGRA VACÍA

5249/OON

€/u.

○

Vida útil: ≥200.000 ciclos

CARACTERÍSTICAS DE APLICACIÓN DEL PRODUCTO

Número de modelo	Configuración	Applicable door specifications/Types				
		Acabado	Peso puerta (Kg)	Altura puerta (mm)	Ancho puerta (mm)	Grueso puerta (mm)
REF. 5250 FH9-30	Hidráulico 1 u./ 1 u. vacía	● Negro	30	≤2000	≤800	≥42
REF. 5251 FH9-60	2u. Hidráulicas	● Otros (sobre pedido): ● Dorado ● Plata	60	≤2400	≤950	
REF. 5252 FH9-80	2u. Hidráulicas/ 1u. vacía		80	≤2800	≤1000	

DATOS TÉCNICOS

- AJUSTE 2D: izquierda/derecha ±2,5 mm; arriba/abajo ±2,5 mm;
- Ángulo máximo de apertura: 125°
- No se mantiene la puerta abierta, para mantener abierta a 90°: se puede combinar con stop SH-1
- Velocidad de cierre ajustable
- Potente fuerza de cierre. Fuerza de cierre: 7 N.m por pieza
- Rango de temperatura aplicable: -5°C ~ 45°C
- Funcionamiento suave y silencioso

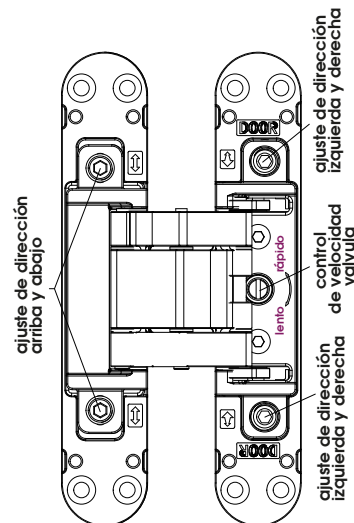
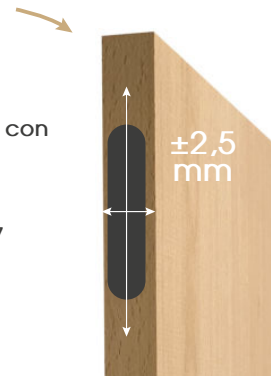

PRODUCTOS SECCIÓN COLOR MARRÓN:

GAMA DE PRODUCTO CON CONDICIONES ESPECIALES PARA DISTRIBUIDORES / CONTACTAR CON EL DEPARTAMENTO DE VENTAS

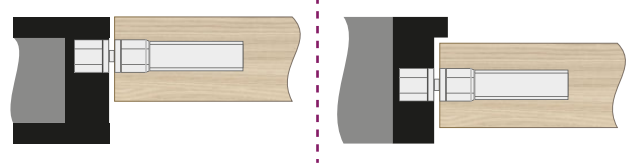
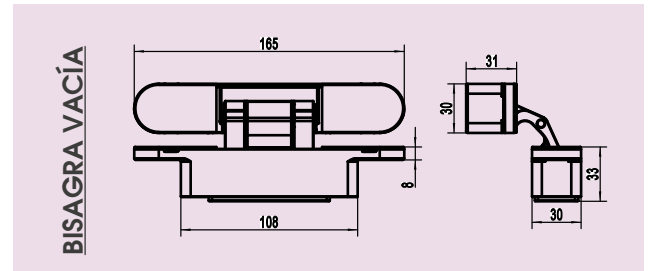
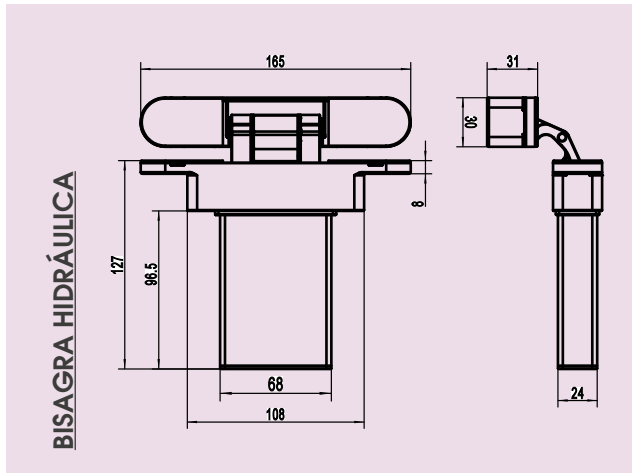

ESQUEMA DE FUNCIONES

Modelo: FH9
(Sin retención)

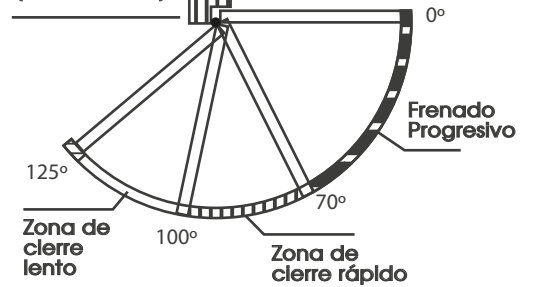

CIERRE PROGRESIVO: Se recomienda para puertas interiores.
CIERRE FINAL: Se recomienda para puertas exteriores y hoteles.

MECANIZACIÓN MADERA

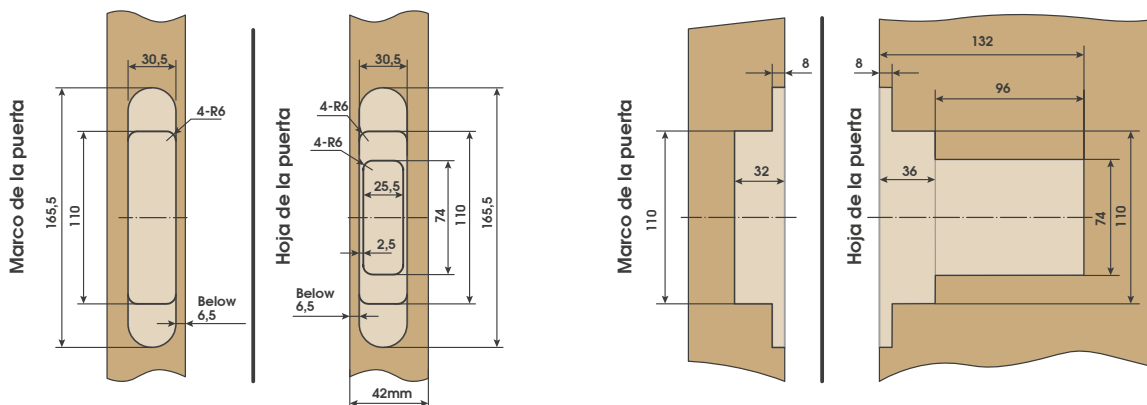

ALTA CALIDAD	DURADERO	SEGURO PARA NIÑOS (ANTI PELLIZCO)	SILENCIOSO	RESISTENCIA AL DESGASTE	MATERIAL DE MÁXIMA CALIDAD
ELEGANTE	BRILLANTE	RESISTENTE AL FUEGO	ANTI ÓXIDO	PINTURA DURADERA	ANTI-PORTAZOS

PRODUCTOS SECCIÓN COLOR MARRÓN:

GAMA DE PRODUCTO CON CONDICIONES ESPECIALES PARA DISTRIBUIDORES / CONTACTAR CON EL DEPARTAMENTO DE VENTAS

FH-10 / BISAGRA HIDRÁULICA

CON RETENCIÓN 90° -MONTAJE A PARED

al Aluminio aeronáutico / INOX 304	40,60,80 o 100 kg/ puerta	Vida útil: 100.000 ciclos	Con mecanización
Mínimo 40 mm	Ancho de 800 a 1200 mm	Puerta madera	

INFORMACIÓN GENERAL

- BISAGRA OCULTA
- ANTIATRAPAMIENTO / ANTIPELLIZCO
- ANTI PORTAZOS / ANTI CORRIENTES

- Ajuste 2D ± 2,5 mm
- Vida útil 200.000 ciclos
- Suave y silencioso
- Potente fuerza de cierre
- Diseño minimalista

KITS

NOIR BLACK NERO ON



SET 3 BISAGRAS 30KG
40 KG
5253/LON Golpe Final
5253/00N Cierre Progressivo

€/Set
○
○



SET 3 BISAGRAS 60KG
60 KG
5254/LON Golpe Final
5254/00N Cierre Progressivo

€/Set
○
○

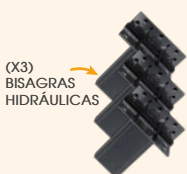

SET 3 BISAGRAS 80KG
80 KG
5255/LON Golpe Final
5255/00N Cierre Progressivo

€/Set
○
○



SET 4 BISAGRAS 80KG
100 KG
5256/LON Golpe Final
5256/00N Cierre Progressivo

€/Set
○
○

Vida útil: ≥ 100.000 ciclos

CARACTERÍSTICAS DE APLICACIÓN DEL PRODUCTO

Número de modelo	Configuración	Applicable door specifications/Types					
		Retención puerta abierta	Acabado	Peso puerta (Kg)	Altura puerta (mm)	Ancho puerta (mm)	Grueso puerta (mm)
FH10-40 5253	Hidráulico 1 u./ 2 u. vacía	<input type="checkbox"/> HO (Con retención) <input type="checkbox"/> NHO (Sin retención)	● Negro ● Otros (sobre pedido): ● Dorado ● Plata	40	≤2000	≤800	≥40
FH10-60 5254	2u. Hidráulicas/ 1u. vacía			60	≤2400	≤950	
FH10-80 5255	3u. Hidráulicas			80	≤2800	≤1000	
FH10-100 5256	3u. Hidráulicas/ 1u. vacía			100	≤3000	≤1200	

DATOS TÉCNICOS

- Ángulo máximo de apertura: 115°
- Zona de cierre rápido: 80°-40°
- Retención a 90°
- Velocidad de cierre ajustable
- Potente fuerza de cierre. Fuerza de cierre: 6-18 N.m (6N.m por bisagra funcional única)
- Rango de temperatura aplicable: -5°C ~ 45°C
- Funcionamiento suave y silencioso

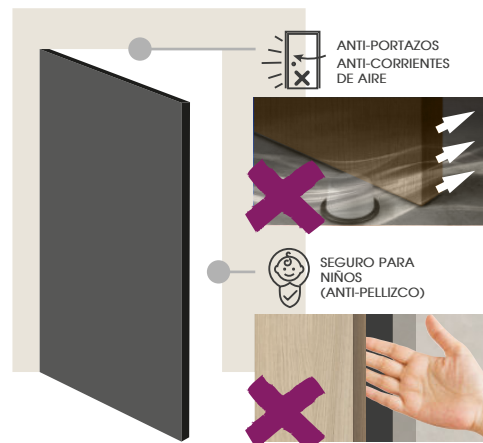

ESQUEMA DE FUNCIONES

Modelo: FH10 (Con retención)

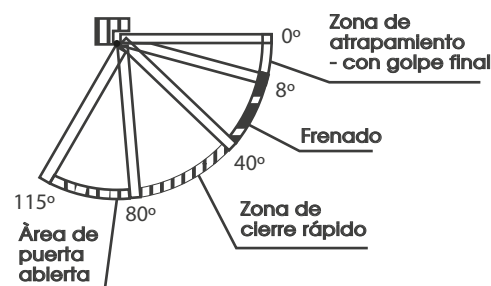

- CIERRE PROGRESIVO:** Se recomienda para puertas interiores.
- CIERRE FINAL:** Se recomienda para puertas exteriores y hoteles.

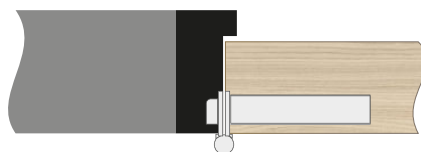
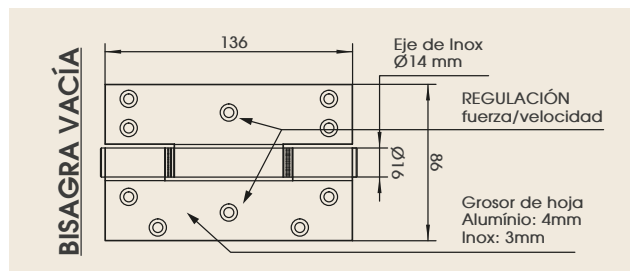
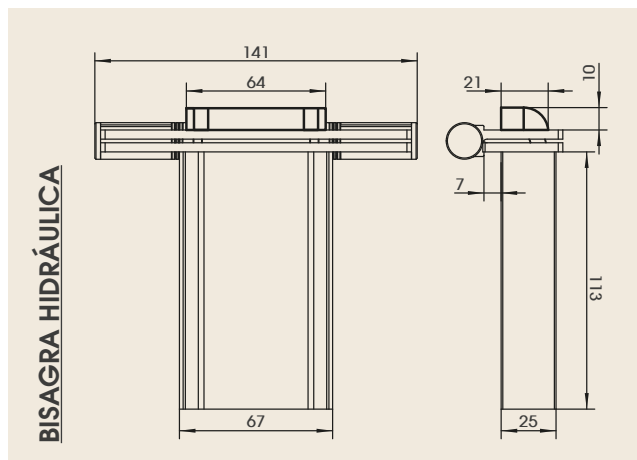

MECANIZACIÓN MADERA

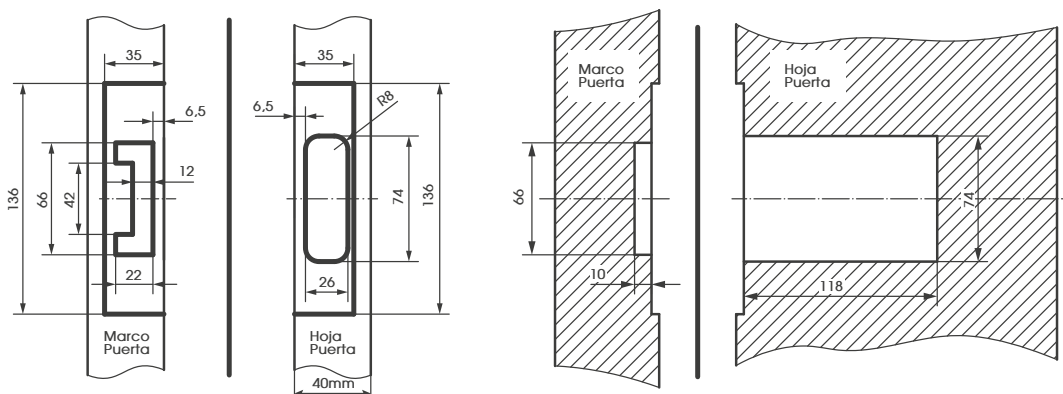

ALTA CALIDAD	DURADERO	SEGURO PARA NIÑOS (ANTI PELLIZCO)	SILENCIOSO	RESISTENCIA AL DESGASTE	MATERIAL DE MÁXIMA CALIDAD
ELEGANTE	BRILLANTE	RESISTENTE AL FUEGO	ANTI ÓXIDO	PINTURA DURADERA	ANTI-PORTAZOS

PRODUCTOS SECCIÓN COLOR MARRÓN:
GAMA DE PRODUCTO CON CONDICIONES ESPECIALES PARA DISTRIBUIDORES / CONTACTAR CON EL DEPARTAMENTO DE VENTAS

FH-6 / BISAGRA HIDRÁULICA

CON RETENCIÓN 90° -MONTAJE A PARED

Al Aluminio	40-100 kg/puerta	Vida útil: 200.000 ciclos	Sin mecanización
Mínimo 38 mm	Ancho 70-120 cm	Puerta madera	

INFORMACIÓN GENERAL

- Funcionamiento suave y silencioso.
- Fuerza de cierre y velocidad de cierre ajustables. Para una mejor instalación y usabilidad.
- Sistema hidráulico eficiente que garantiza un uso prolongado sin fugas de aceite, suave y liso.

- ANTIATRAPAMIENTO / ANTIPELLIZCO
- ANTI PORTAZOS / ANTI CORRIENTES

BISAGRA

NOIR BLACK NERO ON



BISAGRA FH-10
HIDRÁULICA 5271/HON
VACÍA 5271/00N

E/u

Vida útil: ≥200.000 ciclos

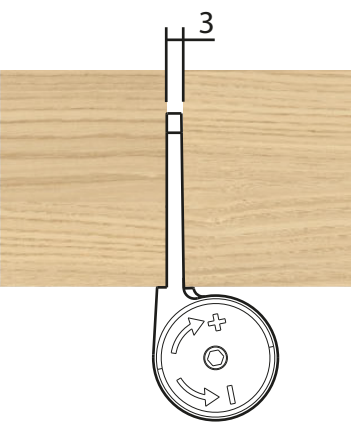

CARACTERÍSTICAS DE APLICACIÓN DEL PRODUCTO

Peso de la puerta (dentro)	Medidas puerta	Cantidad	Sujección
10-40 kg	2000 mm x 700 mm	1 Bisagra hidráulica + 1 bisagra vacía	Mínimo 2 bisagras, una hidráulica, pero se recomienda 2 bisagras hidráulicas
40-60 kg	2100 mm x 850 mm	3 Bisagras hidráulicas	Si la altura es superior a 2100 mm, agregar una bisagra vacía (3 bisagras hidráulicas son más efectivas)
60-100 kg	2500 mm x 1200 mm	4 Bisagras hidráulicas	Para alturas de puertas no convencionales, se deben agregar proporcionalmente para obtener mejores resultados.

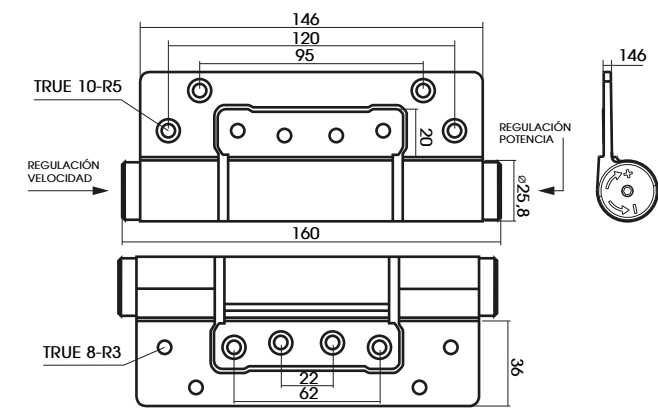

POSICIÓN DE INSTALACIÓN

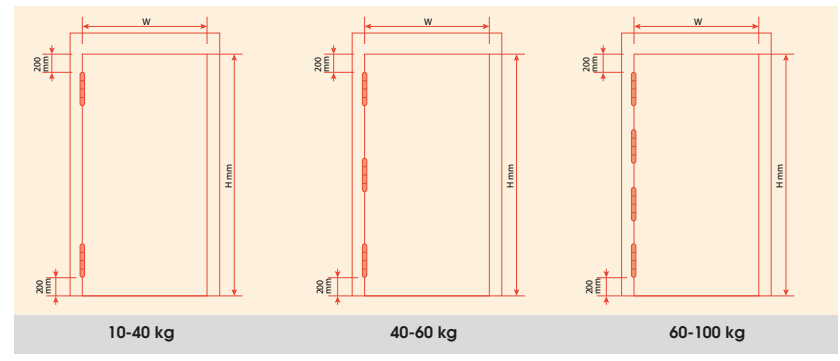

FH-5 / BISAGRA HIDRÁULICA

CON RETENCIÓN 90° -MONTAJE A PARED

al Aluminio	40-100 kg/puerta	Vida útil: 200.000 ciclos	Sin mecanización
Mínimo 38 mm	Ancho 70-120 cm	Puerta madera	

INFORMACIÓN GENERAL

- ANTIATRAPAMIENTO / ANTIPELLIZCO
- ANTI PORTAZOS / ANTI CORRIENTES

- Funcionamiento suave y silencioso.
- Fuerza de cierre y velocidad de cierre ajustables. Para una mejor instalación y usabilidad.
- Sistema hidráulico eficiente que garantiza un uso prolongado sin fugas de aceite, suave y liso.

BISAGRA

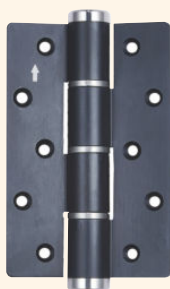

BISAGRA FH-10
HIDRÁULICA 5270/HON
VACÍA 5270/00N

NOIR
BLACK
NERO
ON



Vida útil: ≥200.000 ciclos

CARACTERÍSTICAS DE APLICACIÓN DEL PRODUCTO

Peso de la puerta (dentro)	Medidas puerta	Cantidad	Sujeción
10-40 kg	2000 mm x 700 mm	1 Bisagra hidráulica + 1 bisagra vacía	Mínimo 2 bisagras, una hidráulica, pero se recomienda 2 bisagras hidráulicas
40-60 kg	2100 mm x 850 mm	3 Bisagras hidráulicas	Si la altura es superior a 2100 mm, agregar una bisagra vacía (3 bisagras hidráulicas son más efectivas)
60-100 kg	2500 mm x 1200 mm	4 Bisagras hidráulicas	Para alturas de puertas no convencionales, se deben agregar proporcionalmente para obtener mejores resultados.

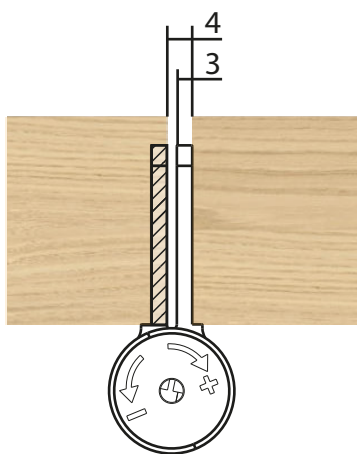
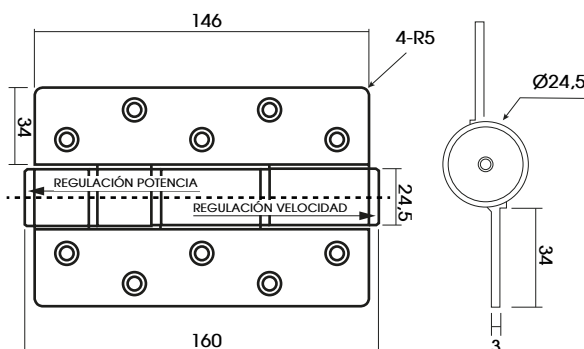

POSICIÓN DE INSTALACIÓN

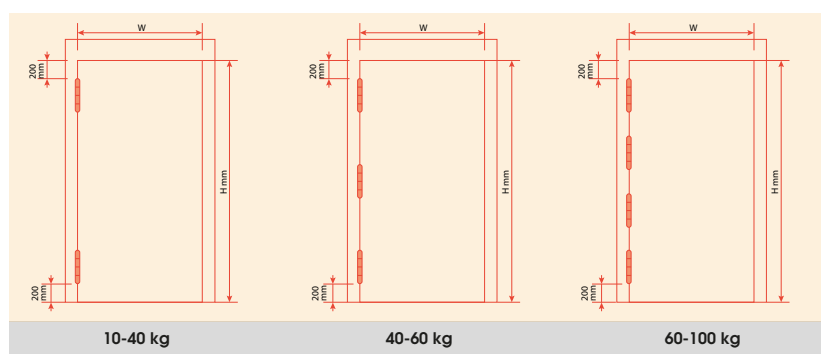

PRODUCTOS SECCIÓN COLOR MARRÓN:

GAMA DE PRODUCTO CON CONDICIONES ESPECIALES PARA DISTRIBUIDORES / CONTACTAR CON EL DEPARTAMENTO DE VENTAS

FH-3 / AMORTIGUADOR HIDRÁULICO OCULTO

MONTAJE PIVOTANTE

Aluminio / INOX 304	65 kg/ puerta	Con mecanización
Máximo 43 mm	Ancho máximo 900 mm	Puerta madera

INFORMACIÓN GENERAL

- AMORTIGUADOR OCULTO
- ANTIATRAPAMIENTO / ANTIPELLIZCO
- ANTI PORTAZOS / ANTI CORRIENTES

- Funcionamiento suave y silencioso.
- Velocidad de cierre ajustable. Para una mejor instalación y usabilidad.
- Sistema hidráulico eficiente que garantiza un uso prolongado sin fugas de aceite, suave y liso.

AMORTIGUADOR

01

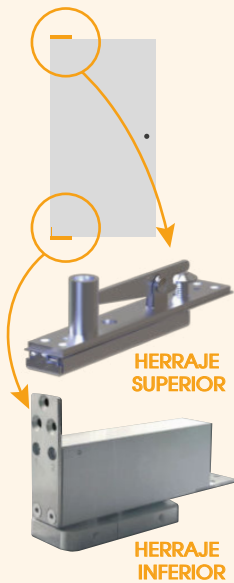

SET AMORTIGUADOR FH-3
(2 HERRAJES: SUPERIOR E INFERIOR)
5260/001

€/Set

o

Vida útil: ≥ 500.000 ciclos

CARACTERÍSTICAS DE APLICACIÓN DEL PRODUCTO

Número del producto	Producto	Especificaciones/tipos de puertas aplicables				
		Peso puerta (kg)	Altura puerta (mm)	Ancho puerta (mm)	Espesor (mm)	Aplicación
FH3-60 5260	AMORTIGUADOR HIDRÁULICO OCULTO PARA PUERTA DE MADERA	≤ 65	≤ 2200	≤ 900	≥ 43	- Puerta de madera - Puerta con perfilera metálica

DATOS TÉCNICOS

- Ángulo abierto: 140° doble acción
- Sección de retención de puerta abierta: 90° y 120-140°
- Dos velocidades ajustables
- Válvula 1: 90°-30°
- Válvula 2: 30°-0°



ESQUEMA DE FUNCIONES

Modelo: FH3

La puerta permanece abierta

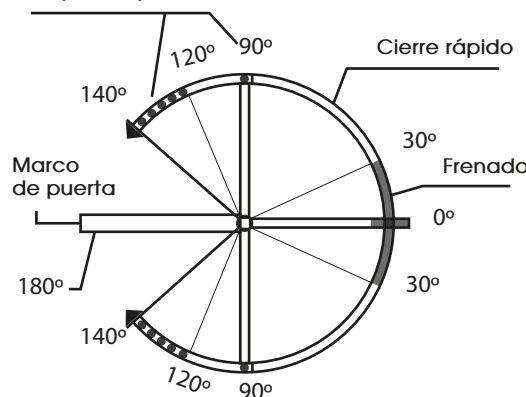

PARA OTROS PESOS CONSULTAR

PRODUCTOS SECCIÓN COLOR MARRÓN:

GAMA DE PRODUCTO CON CONDICIONES ESPECIALES PARA DISTRIBUIDORES / CONTACTAR CON EL DEPARTAMENTO DE VENTAS

**DIMENSIONES
PRODUCTO**

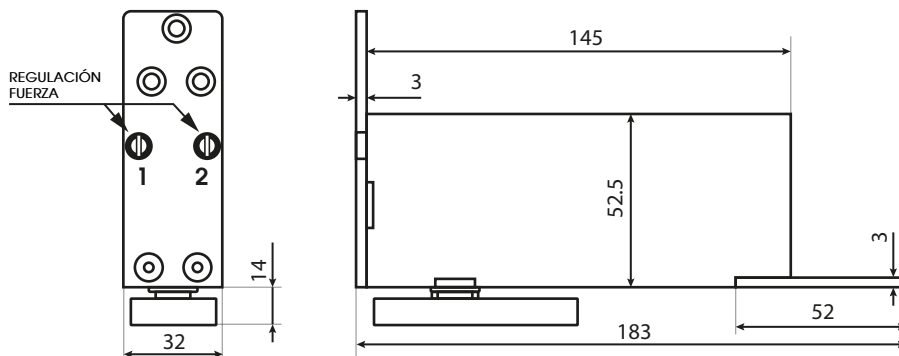

MECANIZACIÓN MADERA

① Parte superior del marco de la puerta

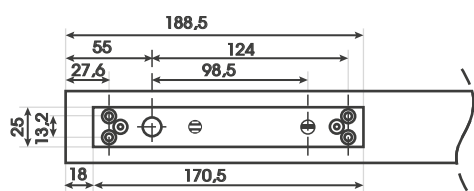

② Parte superior de la hoja de la puerta

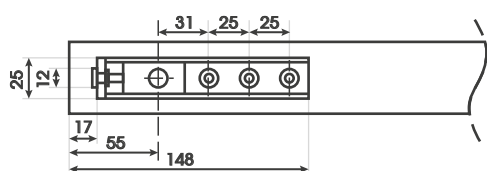

③ Parte inferior de la hoja de la puerta

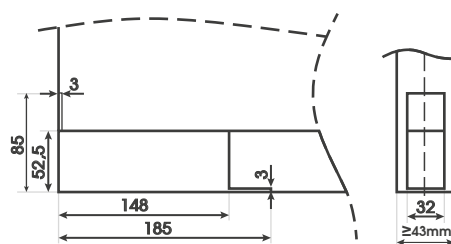

ALTA CALIDAD



DURADERO



SEGURO PARA NIÑOS (ANTI PELLIZCO)



SILENCIOSO



ELEGANTE



BRILLANTE



RESISTENTE AL FUEGO



ANTI-PORTAZOS

PRODUCTOS SECCIÓN COLOR MARRÓN:

GAMA DE PRODUCTO CON CONDICIONES ESPECIALES PARA DISTRIBUIDORES / CONTACTAR CON EL DEPARTAMENTO DE VENTAS

AH-8 / AMORTIGUADOR HIDRÁULICO OCULTO

ANTI ATRAPAMIENTO Y ANTI PORTAZO

al Acero / Aluminio	50 kg/ puerta	Con mecanización
40-60 mm	Ancho máximo 900 mm	Puerta madera

INFORMACIÓN GENERAL

- AMORTIGUADOR OCULTO
- ANTIATRAPAMIENTO / ANTIPELLIZCO
- ANTI PORTAZOS / ANTI CORRIENTES

- Funcionamiento suave y silencioso.

- Para puertas de 40 a 60 mm de espesor.

AMORTIGUADOR

22

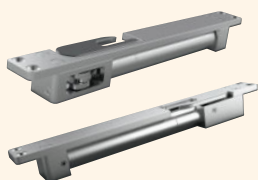

BISAGRA FH-10

DERECHA
5262/D22
IZQUIERDA
5262/Z22

€/u.

○

○

Vida útil: ≥ 100.000 ciclos

CARACTERÍSTICAS DE APLICACIÓN DEL PRODUCTO

Número del producto	Producto	Especificaciones/tipos de puertas aplicables				
		Peso puerta (Kg)	Altura puerta (mm)	Ancho puerta (mm)	Espesor (mm)	Aplicación
5262/Z22	P8 Amortiguador de puerta hidráulico oculto/Abertura a la izquierda	≤50	≤2200	≤900	40-60	Puerta de madera
5262/D22	P8 Amortiguador de puerta hidráulico oculto/Abertura a la derecha					

ELEMENTOS

DATOS TÉCNICOS

Material	Acero y Aluminio
Peso de puerta adecuado	≤50 Kg
Ancho de puerta adecuado	≤900 mm
Dirección	Apertura derecha o izquierda
Temperatura adecuada	-5°C ~ 40°C
Fuerza de cierre	5N.m
Vida útil	100.000 ciclos
Aplicación	Puertas interiores para habitaciones residenciales

DIRECCIÓN DE INSTALACIÓN



PERSONAS EN ESTA POSICIÓN

El producto tiene mano derecha y mano izquierda como se muestra en la imagen, elija el modelo correcto para su puerta.

ESQUEMA DE FUNCIONES

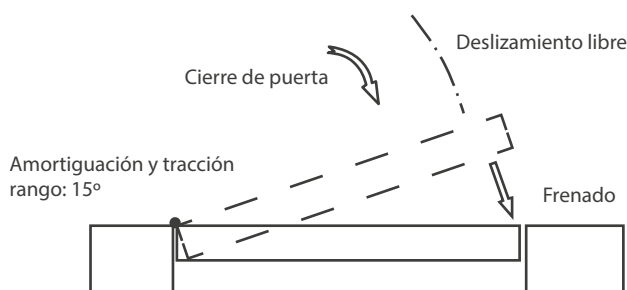

PRODUCTOS SECCIÓN COLOR MARRÓN:

GAMA DE PRODUCTO CON CONDICIONES ESPECIALES PARA DISTRIBUIDORES / CONTACTAR CON EL DEPARTAMENTO DE VENTAS

DIMENSIONES PRODUCTO

CUERPO DEL AMORTIGUADOR

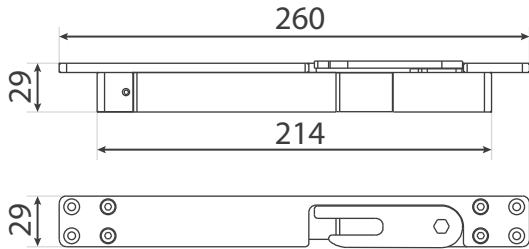

PERNIO PREMARCO

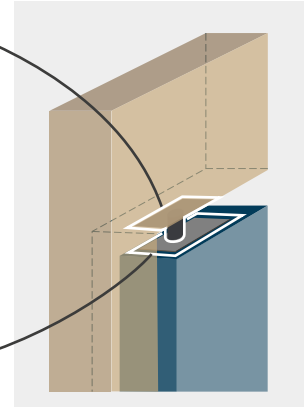
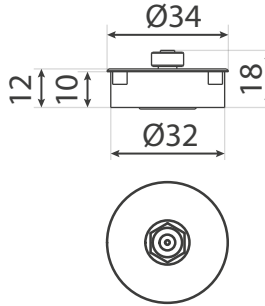

MECANIZACIÓN MADERA

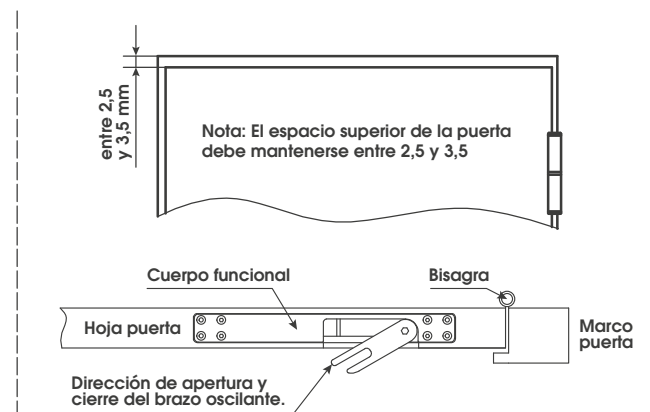
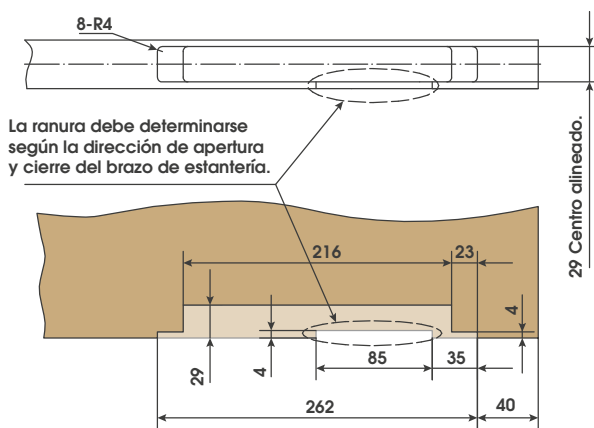

ALTA CALIDAD	DURADERO	SEGURO PARA NIÑOS (ANTI PELLIZCO)	SILENCIOSO	RESISTENCIA AL DESGASTE	MATERIAL DE MÁXIMA CALIDAD
ELEGANTE	BRILLANTE	RESISTENTE AL FUEGO	ANTI ÓXIDO	PINTURA DURADERA	ANTI-PORTAZOS

PRODUCTOS SECCIÓN COLOR MARRÓN:

GAMA DE PRODUCTO CON CONDICIONES ESPECIALES PARA DISTRIBUIDORES / CONTACTAR CON EL DEPARTAMENTO DE VENTAS

AH-7 / AMORTIGUADOR HIDRÁULICO

APLICABLE A PUERTAS YA EXISTENTES

 Acero / Aluminio	 50 kg/ puerta	 Con mecanización
 40-60 mm	 Ancho máximo 900 mm	 Puerta madera

INFORMACIÓN GENERAL

- ANTIATRAPAMIENTO / ANTIPELLIZCO
- ANTI PORTAZOS / ANTI CORRIENTES

- Fabricado con máquinas de muy alta precisión.

- Se puede usar en cualquier puerta, incluso para puertas ya existentes.

AMORTIGUADOR



AMORTIGUADOR HIDRÁULICO AH-7
HIDRÁULICA
5261/DON
VACÍA
5261/ZON

NEGRO
NOIR
BLACK
NERO
ON



Vida útil: ≥ 100.000 ciclos

CARACTERÍSTICAS DE APLICACIÓN DEL PRODUCTO

Número del producto	Producto	Especificaciones/tipos de puertas aplicables					Aplicación
		Acabado	Peso puerta (Kg)	Altura puerta (mm)	Ancho puerta (mm)	Espesor (mm)	
5261/D..	AH7 Amortiguador hidráulico DERECHA	● Negro Otras (sobre pedido): ● Gris ● Palisandro ● Blanco ● Natural	≤50	≤2200	≤900	40-60	Puerta de madera
5261/Z..	AH7 Amortiguador hidráulico IZQUIERDA						

ELEMENTOS	DATOS TÉCNICOS
Material	Acero y Aluminio
Acabado	Blanco, Gris, Negro, Palisandro, Natural
Peso de puerta adecuado	≤60 Kg
Ancho de puerta adecuado	≤900 mm
Dirección	Temperatura adecuada
Temperatura adecuada	-5°C ~ 40°C
Fuerza de cierre	3.5N.m
Vida útil	100.000 ciclos
Aplicación	Puertas interiores para habitaciones residenciales

DIRECCIÓN DE INSTALACIÓN



PERSONAS EN ESTA POSICIÓN

El producto tiene mano derecha y mano izquierda como se muestra en la imagen, elija el modelo correcto para su puerta.

ESQUEMA DE FUNCIONES

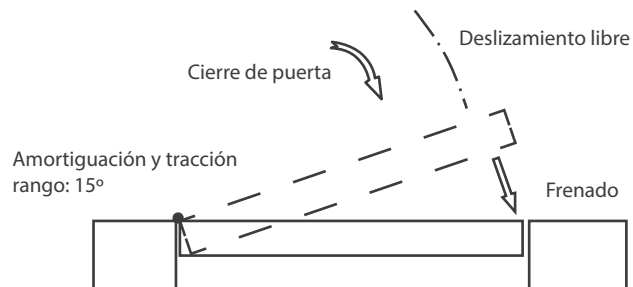

PRODUCTOS SECCIÓN COLOR MARRÓN:

GAMA DE PRODUCTO CON CONDICIONES ESPECIALES PARA DISTRIBUIDORES / CONTACTAR CON EL DEPARTAMENTO DE VENTAS

DIMENSIONES PRODUCTO

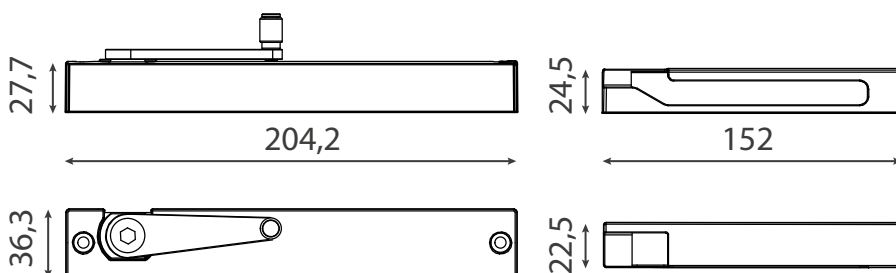

ALTA CALIDAD



DURADERO



SEGURO PARA NIÑOS (ANTI PELLIZCO)



SILENCIOSO



RESISTENCIA AL DESGASTE



MATERIAL DE MÁXIMA CALIDAD



ELEGANTE



BRILLANTE



RESISTENTE AL FUEGO



ANTI ÓXIDO



PINTURA DURADERA



ANTI-PORTAZOS

PRODUCTOS SECCIÓN COLOR MARRÓN:

GAMA DE PRODUCTO CON CONDICIONES ESPECIALES PARA DISTRIBUIDORES / CONTACTAR CON EL DEPARTAMENTO DE VENTAS

SH-1 / STOP HIDRÁULICO UNIVERSAL

RETENCIÓN ANTI REBOTE, TODO TIPO DE PUERTAS DE MADERA

al Acero / Aluminio	50 kg/ puerta	Con mecanización
40-60 mm	Ancho máximo 900 mm	Puerta madera

INFORMACIÓN GENERAL

- ANTIATRAPAMIENTO / ANTIPELLIZCO
- ANTI PORTAZOS / ANTI CORRIENTES

Se puede usar en combinación con las bisagras hidráulicas ocultas FH9 para obtener la retención de la puerta a 90°.

AMORTIGUADOR

NEGRO
NOIR
BLACK
NERO
ON

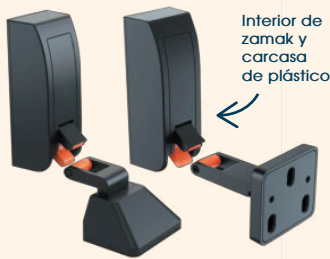

AMORTIGUADOR HIDRÁULICO AH-7

PARED
5263/00N
SUELO
5264/00N



Para otros acabados consultar

DATOS TÉCNICOS

1. Fuerza de impacto máxima: 300-600N
2. Velocidad de amortiguación: aproximadamente 0,4 m/s
3. Carrera (distancia al punto final cuando se genera amortiguación): 8 mm
4. Vida útil: 100.000 ciclos

MÁXIMA FACILIDAD DE MONTAJE



DIAGRAMA DEL PRINCIPIO DE FUNCIONAMIENTO DEL PRODUCTO

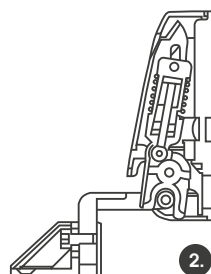
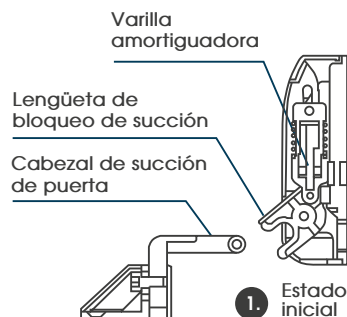

En el proceso de uso, la succión de la puerta debido a una fuerza externa golpea el rodillo fijado en la parte inferior del cabezal de succión de la puerta, el pestillo dentro de la succión de la puerta saldrá del estado de bloqueo, mientras tanto la varilla amortiguadora absorberá el gran impacto y alcanzará un efecto amortiguador.

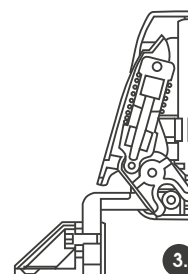

Debido al efecto amortiguador de la varilla amortiguadora, el pestillo solo se desviará lentamente, desempeñando así el papel de succión silenciosa.

PRODUCTOS SECCIÓN COLOR MARRÓN:

GAMA DE PRODUCTO CON CONDICIONES ESPECIALES PARA DISTRIBUIDORES / CONTACTAR CON EL DEPARTAMENTO DE VENTAS

DIMENSIONES PRODUCTO

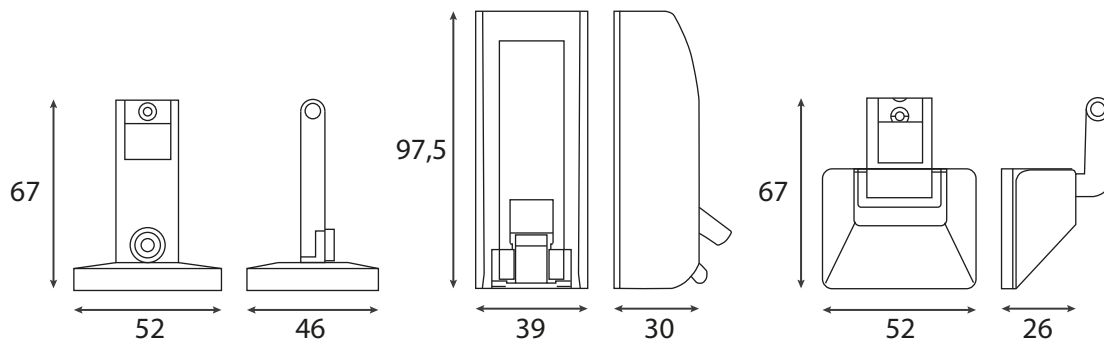

ALTA CALIDAD	DURADERO	SEGURO PARA NIÑOS (ANTI PELLIZCO)	SILENCIOSO	RESISTENCIA AL DESGASTE	MATERIAL DE MÁXIMA CALIDAD
ELEGANTE	BRILLANTE	RESISTENTE AL FUEGO	ANTI ÓXIDO	PINTURA DURADERA	ANTI-PORTAZOS

PRODUCTOS SECCIÓN COLOR MARRÓN:
GAMA DE PRODUCTO CON CONDICIONES ESPECIALES PARA DISTRIBUIDORES / CONTACTAR CON EL DEPARTAMENTO DE VENTAS

B-150 BISAGRA OCULTA NO HIDRÁULICA / CON REGULACIÓN 3D

zn Zamak	2 bisagras 40 kg/ puerta	Con mecani- zación
Mínimo 35 mm	Ancho máximo 850 mm	Puerta madera

INFORMACIÓN GENERAL
- INSTALACIÓN OCULTA
- ANGULO DE APERTURA 180°

Tratamiento de la superficie del producto: cromo perlado, niquelado, revestimiento de cobre, pintura de aerosol

Las juntas de los cojinetes están hechas de material PA66 lubricado y resistente al desgaste.

El ajuste izquierdo y derecho utiliza tornillos de rosca fina para un ajuste más preciso.

CARACTERÍSTICAS DE APLICACIÓN DEL PRODUCTO

Número del producto	Producto	Especificaciones/tipos de puertas aplicables					Aplicación
		Acabado	Peso puerta (Kg)	Altura puerta (mm)	Ancho puerta (mm)	Espesor (mm)	
5275/00N	B-150 Bisagra no Hidráulica	● Negro ● Gris	2u.- 40	max. 2400	max. 850	min. 35	Puerta de madera

BISAGRA

NEGRO
NOIR
BLACK
NERO
ON

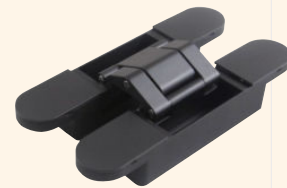

BISAGRA NO HIDRÁULICA B-150
*5275/00N

EU

*O

AJUSTE 3D

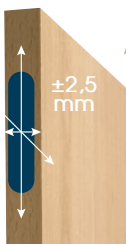

Permite ajustar:
- Derecha/Izquierda
- Arriba/Abajo
- Adelante/Atrás

Apto para puertas de madera, puertas de acero, puertas plegables, etc.

Material: aleación de zinc

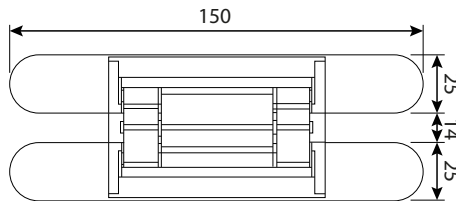

MECANIZACIÓN MADERA

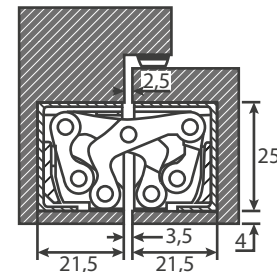
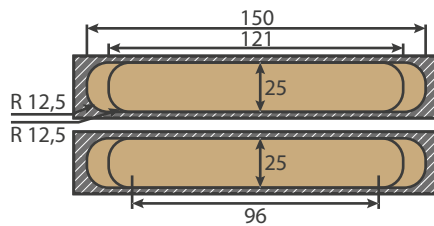
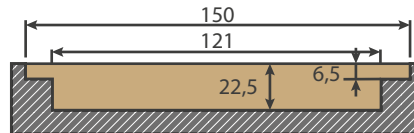

SMART-LOCKS MADERA

CERRADURAS "SMART" - INTELIGENTES



CERRADURA SMART-LOCK MADERA
serrure à bois smart-lock
smart-lock wood lock
serratura in legno smart-lock
5545/00N €/u.



CERRADURA SMART-LOCK MADERA
serrure à bois smart-lock
smart-lock wood lock
serratura in legno smart-lock
5546/00N €/u.

NEGRO
NOIR
BLACK
NERO
ON

35-65 mm
Ø 60mm

35-65 mm
Ø 60mm



MÚLTIPLES
OPCIONES
DE APERTURA



Cerraduras compatibles con sistema de domótica mediante APP Smart Life

Conexión WIFI a distancia mediante gateway "TUYA" / Consultar para más información.

NOVEDAD



CERRADURA CON PASSWORD / RFID - BLUETOOTH
SERRURE AVEC MOT DE PASSE/RFID-BLUETOOTH
LOCK WITH PASSWORD / RFID - BLUETOOTH
SERRATURA CON PASSWORD / RFID - BLUETOOTH
***4259/028**

Incluye 3 tarjetas RFID



TARJETA RFID
CARTE RFID
RFID CARD
SCHEDE RFID
***4259/C09**

INOX SAT PLÁSTICO
INOX SAT PLASTIQUE
S.S.S. PLASTIC
INOX SAT PLASTICA

28 09
inox s.s. Zn CE €/u

*0

PLA €/u

*0

HYDRO

BISAGRAS HIDRÁULICAS



BISAGRAS HIDRÁULICAS PARA PUERTAS DE MADERA
3 PIEZAS (1 HIDRÁULICA, 2 VACÍAS)
CHARNIÈRES HYDRAULIQUES POUR PORTES EN BOIS
3 PIÈCES (1 HYDRAULIQUES, 2 GRATUITE)
HYDRAULIC HINGES FOR WOODEN DOORS
3 PIECES (1 HYDRAULIC, 2 FREE)
CERNIERE IDRAULICHE PER PORTE IN LEGNO
3 PEZZI (1 IDRAULICI, 2 GRATUITO)

*1532/001 Der /Set 3 bisagras
*1533/001 Izq /Set 3 bisagras

charnière mur ferme-porte hydraulique réglable
wall hinge hydraulic spring floor adjustable
cerniera parete chiudiporta idraulico regolabile

BISAGRA HIDRÁULICA Guía de instalación (AluH)

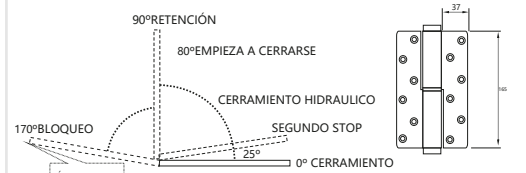

- Hay 3 piezas en cada juego para un peso de 100Kg.
- Corte de madera como guía.

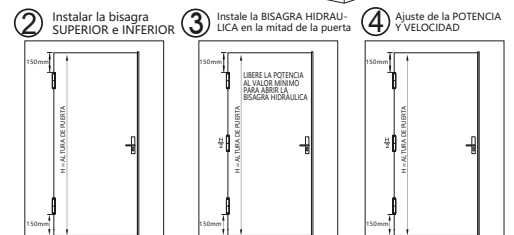

MODO DE AJUSTE

VELOCIDAD Y FUERZA EN EL LADO DE LA BISAGRA



HACIA LA DERECHA EL VALOR HACE QUE LA PUERTA SE CIERRE LENTAMENTE ABAJO
HACIA LA IZQUIERDA EL VALOR HACE QUE LA PUERTA SE CIERRE MAS RAPIDO



HACIA LA DERECHA EL VALOR HACE QUE LA PUERTA SE CIERRE CON MAS FUERZA
HACIA LA IZQUIERDA EL VALOR HACE QUE LA PUERTA SE CIERRE CON MENOS FUERZA

GUÍA DE DIRECCIÓN DE BISAGRAS

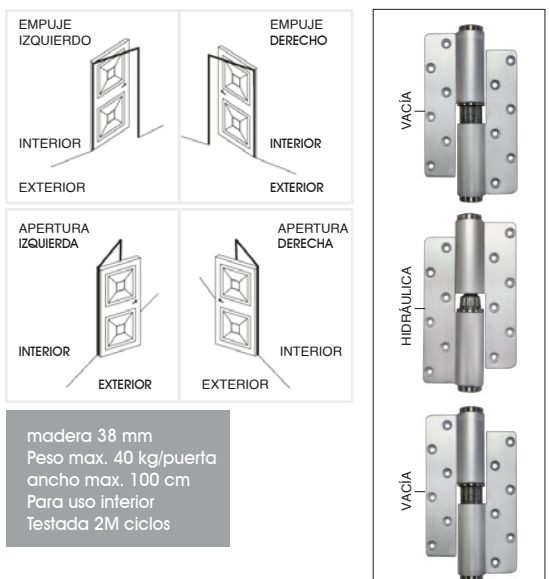

madera 38 mm
Peso max. 40 kg/puerta
ancho max. 100 cm
Para uso interior
Testada 2M ciclos

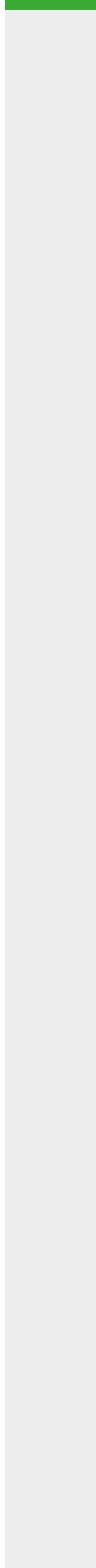



instal.

ILUMINACIÓN

SISTEMAS CON ILUMINACIÓN ECOLÓGICA

KADÍ CREMALLERA ELEKTRIC
EXPLOSIONADO GENERAL
MONTAJE EN SERIE
MONTAJE ELÉCTRICO
MONTAJE PLAFONES
MONTAJE CREM. ELEKTR.
(ESQUEMA) ACCES.PRIMO
TABLA DE PESOS
COMPORTAMIENTO PESOS
PLUG & PLAY
DESPIECE ACCESORIOS
COMPONENTES POR PIEZA
COMP. FACIL CONEXIÓN
ACCES. CON COMPON.

KADÍ PHARMA ELEKTRIC
EXPLOSIONADO GENERAL
MONTAJE EN SERIE
MONTAJE CON MAGNETIC
MONTAJE CON EASY
MONTAJE PLAFONES
INF. TOPE, GRAPAS, CABLE
INF. CARRIL ELÉCTRICO
INF. CONECTOR
INF. CARRIL-CABLE
(ESQUEMA) ACCES.PRIMO
TABLA DE PESOS
COMPORTAMIENTO PESOS
PLUG & PLAY
COMPONENTES POR PIEZA
COMP. FACIL CONEXIÓN
PIES Y ANCLAJES
TIRANTES
JUNTAS Y TAPAS
ACCES. CON COMPON.

KADÍ PRIMO ELEKTRIC
EXPLOSIONADO GENERAL
MONTAJE EN SERIE
MONTAJE CON MAGNETIC
MONTAJE CON EASY
INF. TOPE, GRAPAS, CABLE
INF. CARRIL ELÉCTRICO
INF. CONECTOR
INF. CARRIL-CABLE
(ESQUEMA) ACCES.PRIMO
TABLA DE PESOS
COMPORTAMIENTO PESOS
PLUG & PLAY
COMPONENTES POR PIEZA
COMP. FACIL CONEXIÓN

NUDOS PRESIÓN
NUDOS BRIDA
TAPONES
TUBO
OTROS ACCESORIOS
ACCES. CON COMPON.

SITEMA CUT-LINE

PERFILES ILUMINACIÓN Y LEDS

EASY LIGHT - MAGNETIC LED
SITEMA
COMPONENTES

EASY LIGHT - EASY
SITEMA
COMPONENTES

SISTEMA VARIO
COMPONENTES



KADÍ CREMALLERA ALU - ELEKTRIC





INSTAL
ILUMINACIÓN

ALU
SYSTEM

KADÍ ELEKTRIC
CREMALLERAS ALU i.191



ESCANEA ESTE QR
PARA VER TODAS
LAS IMÁGENES DE LA
CREMALLERA ALU



KADÍ CREMALLERA ELEKTRIC

Ejemplos orientativos
de distintas posibilidades,
distribuciones y
aplicaciones



EXPLOSIONADO GENERAL

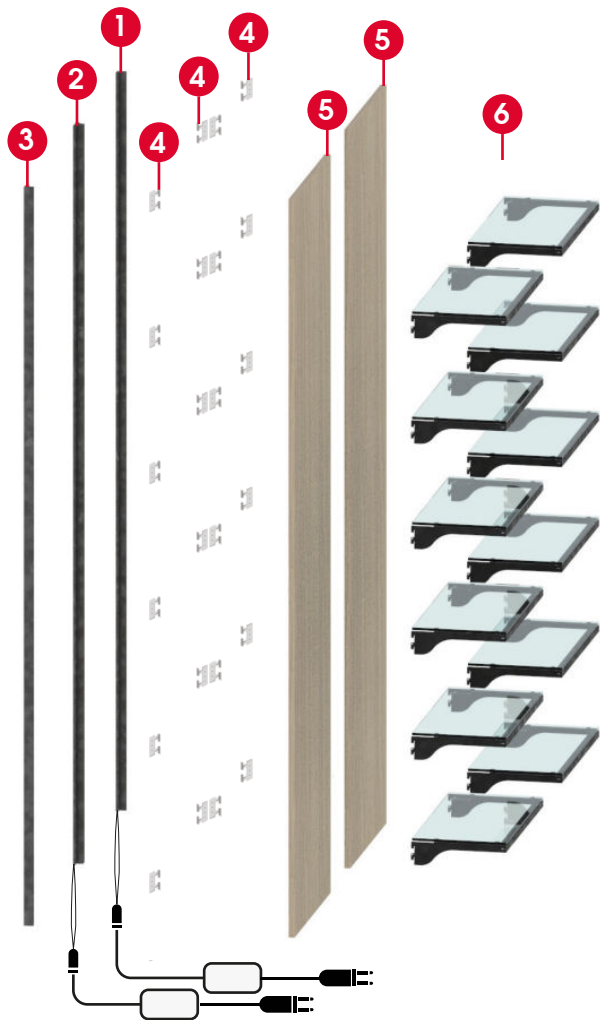

MONTAJE EN SERIE

Colocar las cremalleras **ELECTRIFICADAS**
EN EL LADO DERECHO de cada panel

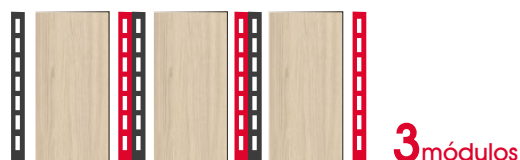

REF: 4872 (CREMALLERA
1 CANAL)
+ 4871 (CARRIL
ELEKTRIC)

Cremalleras
electrificadas
exteriores
- 1 canal

REF: 4870 (CREMALLERA
2 CANALES)
+ 4871 (CARRIL
ELEKTRIC)

Cremalleras
electrificadas
interiores
- 2 canales

REF: 4872 (CREMALLERA
1 CANAL)

Cremalleras
sin carril
eléctrico
exteriores
- 1 canal

1 Cremallera
electrificada
- 1 canal
REF: 4872
+4871



2 Cremallera
electrificada
- 2 canales
REF: 4870
+4871



3 Cremallera
sin carril
eléctrico
- 1 canal
REF: 4872



4 Grapas para
colgar
paneles
2 posibles
modelos:
- Clásicas
- Modelo
rediseñado
con aplicación
frontal



5 Paneles
(NO
INCLUIDOS)



6 Accesorios
Personalizable:
- Estantes
- Barras
- Perroquets



MONTAJE ELÉCTRICO

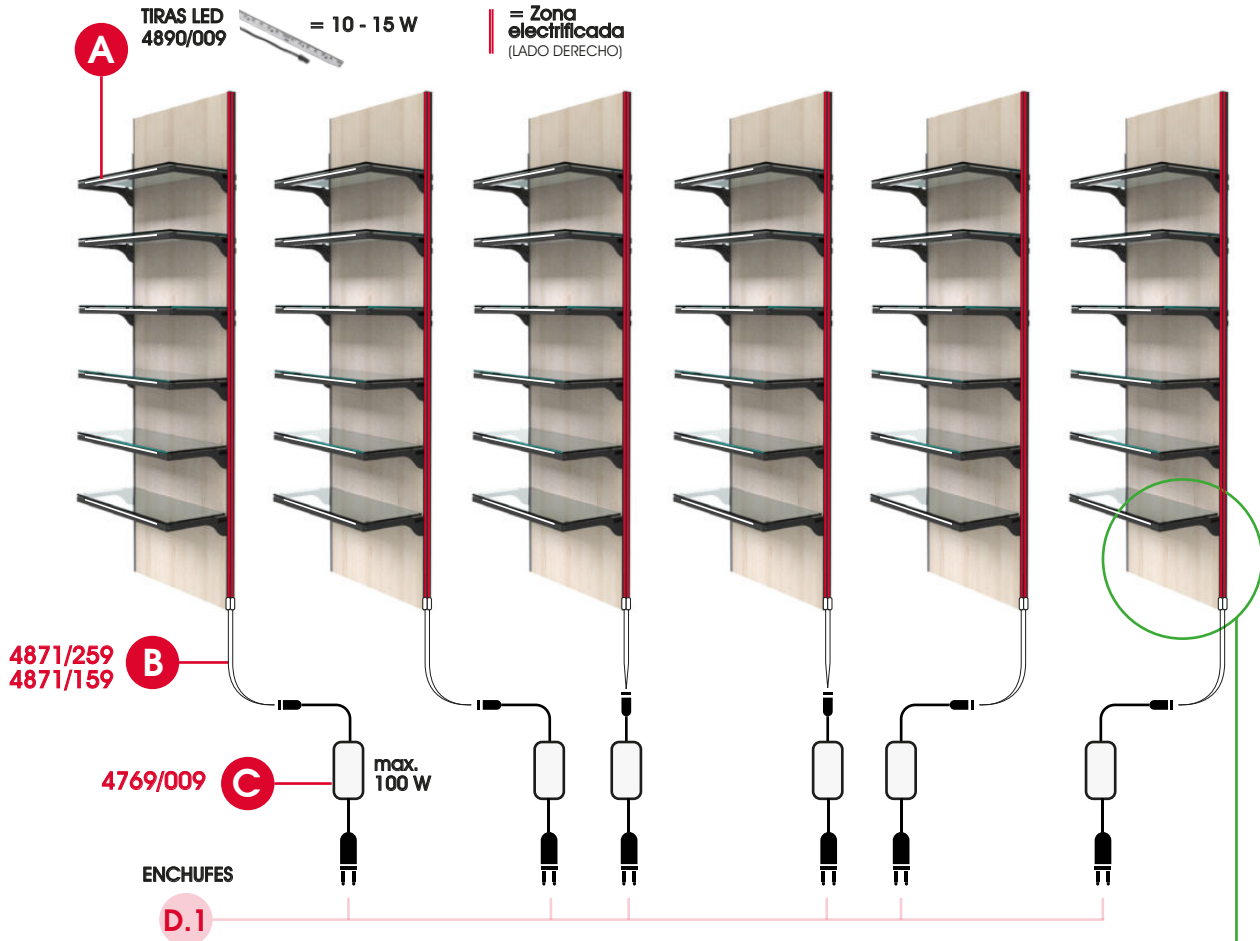

- A** Tiras LED (6 ud. por transformador)
- B** Cable con mini conector
LONGITUD DEL CABLE - 1M
- C** Transformador (Cada panel debe llevar su transformador)
- D** Regleta de distribución
- D.1** Enchufe

- ES** • El carril electrificado lleva soldado el cable de conexión en la parte inferior. En el caso de prescindir de este conector, prestar atención a la polaridad de los cables para el correcto funcionamiento de la nueva conexión.
- FR** • La voie électrifiée porte le câble de connexion au conducteur en bas. En cas de suppression avec ce connecteur, faites attention à la polarité des câbles pour le bon fonctionnement de la nouvelle connexion.
- EN** • The electrified track carries the connection cable to the driver at the bottom. In the case of dispensing with this connector, pay attention to the polarity of the cables for the correct functioning of the new connection.
- IT** • Il binario elettrificato ha il cavo di connessione al driver saldato nella parte inferiore. Nel caso di prescindere del connettore, controllare la polarità dei cavi per assicurare il corretto funzionamento della nuova connessione.

Cualquier manipulación invalida la garantía del fabricante

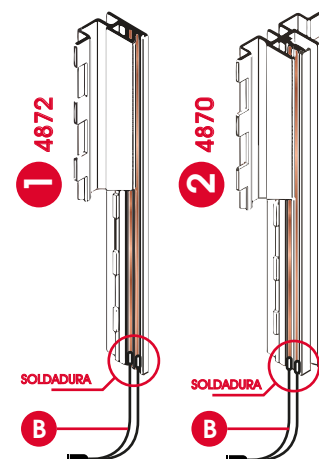



MONTAJE DE LOS PLAFONES A LAS CREMALLERAS

SISTEMA MEDIANTE ENGANCHES

ENGANCHES 4616/034

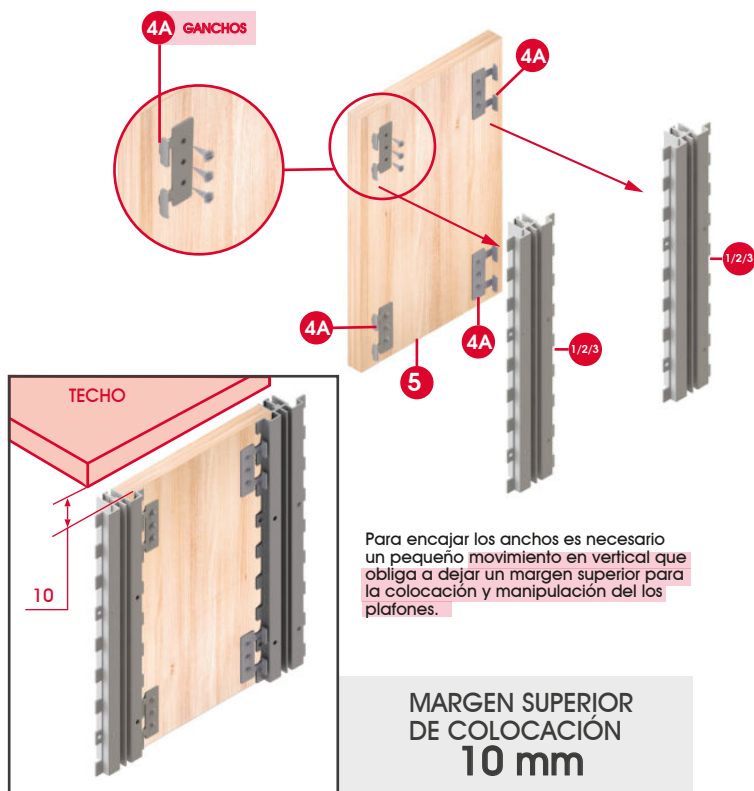

- 1 Cremallera electrificada 1 carril
- 2 Cremallera 2 carriles
- 3 Cremallera sin electrificar 1 carril
- 4 Ganchos / Grapas
- 5 Panel

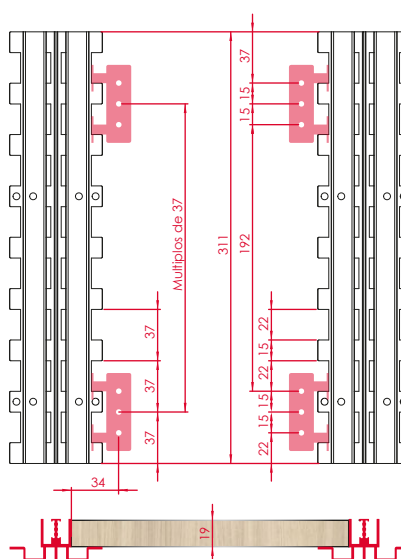

SISTEMA MEDIANTE CLIPAJES

CLIPAJES 4607/028

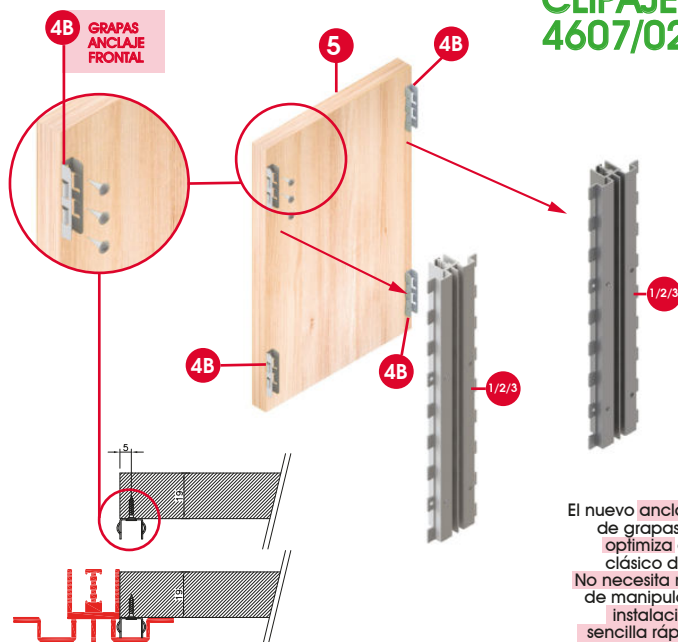



MONTAJE CREMALLERAS ELECTRIFICADAS

1

CREMALLERA ELECTRIFICADA 1 CANAL

REF.
4872

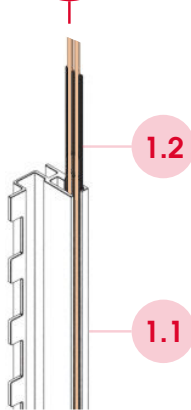

1.1 Cremallera

1.2 Carril eléctrico

2 POSIBLES MEDIDAS (30 - 45 FONDO)

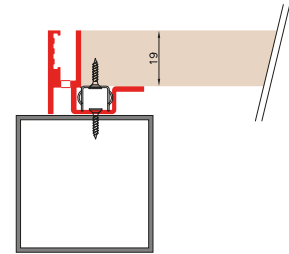
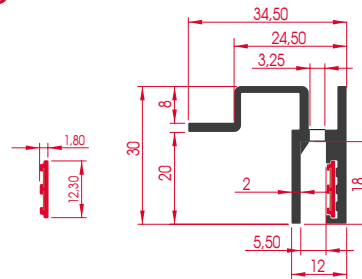
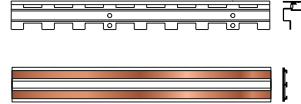

2

CREMALLERA ELECTRIFICADA 2 CANALES

REF.
4870

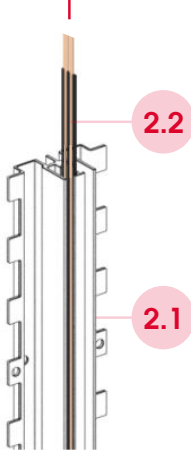

2.1 Cremallera

2.2 Carril eléctrico

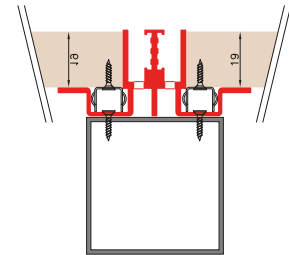
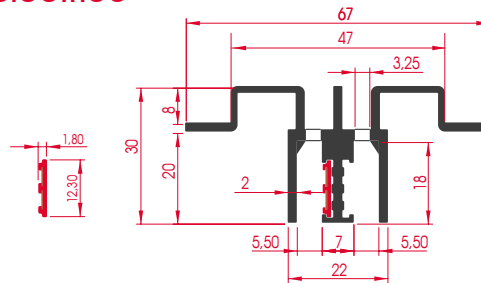
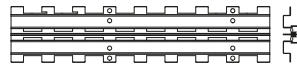

3

NOVA CREMALLERA ELECTRIFICADA 1 CANAL

REF.
4874

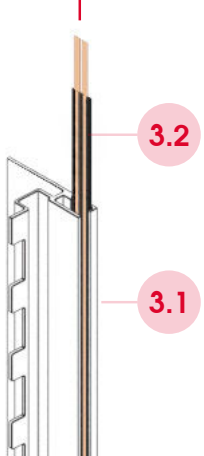

1.1 Cremallera

1.2 Carril eléctrico

2 POSIBLES MEDIDAS (30 - 45 FONDO)

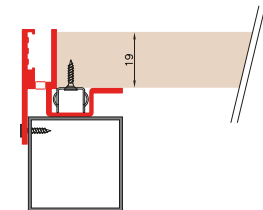
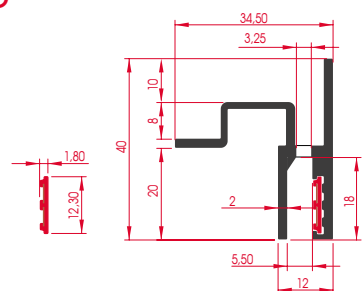
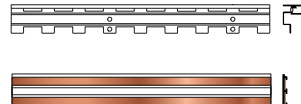



ACCESORIOS CREMALLERA ALU

● Vidrio ● Madera

ESTANTES

CARGA LIGERA



3890/1..



3891/1..



CARGA MEDIA



3894/1..



CARGA ALTA



3895/1..

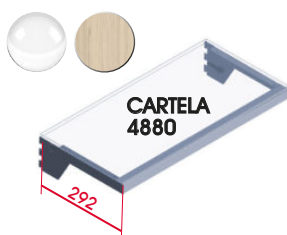

3896/1..



CARGA MEDIA



5370/00B

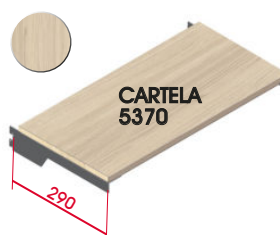

CARGA MEDIA



4636/1..



3898/1..



3897/1..



BARRAS

CARGA LIGERA



4901/1..



4910/1..

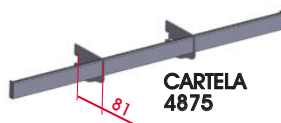

PERROQUET

CARGA LIGERA



4725/1..





TABLA DE PESOS



COMPORTAMIENTO DE CARGA

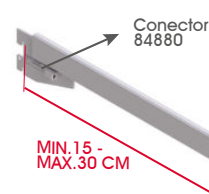
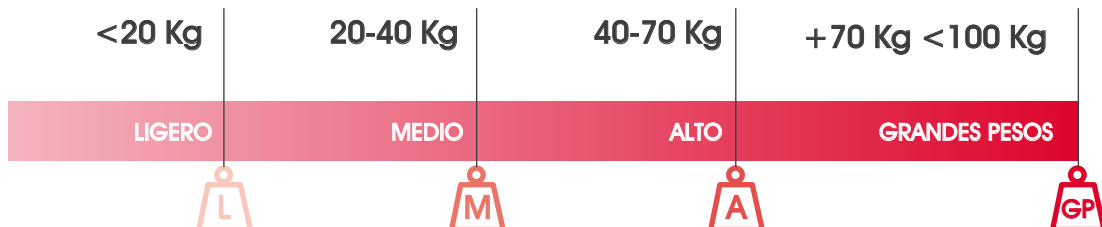

Puntos conflictivos de carga



La inclinación puede variar dependiendo del peso y la flexibilidad del aluminio.

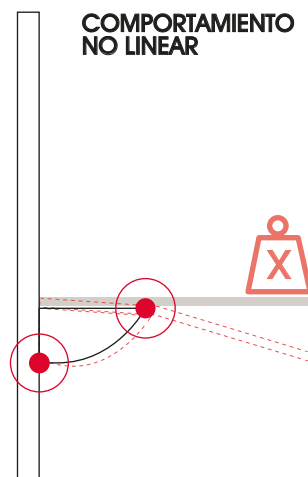
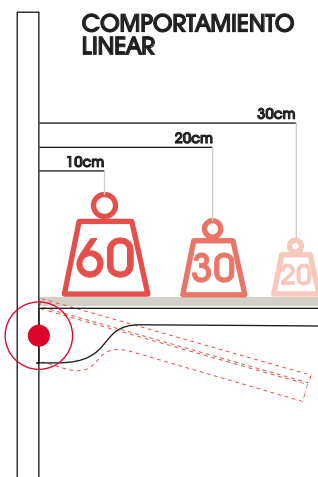

PLUG & PLAY

AL ENCAJAR SE ENCIENDE 

Con el sistema PLUG & PLAY el montaje de los módulos de carga resulta fácil, rápido y muy práctico, ya que solo encajando las cartelas a las cremalleras, el circuito eléctrico queda totalmente conectado y el LED encendido.

- FÁCIL
- RÁPIDO
- PRÁCTICO

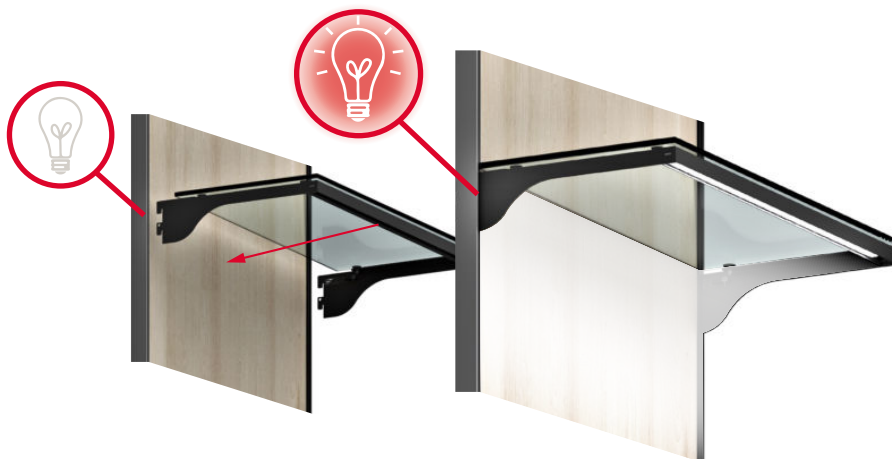



DESPIECE ACCESORIOS

PERROQUET



CARGA LIGERA

4725/1..

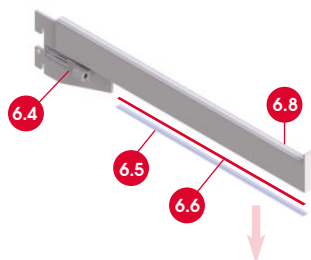

6.1 VIDRIO
Base de
los estantes

6.2 MADERA
Base de
los estantes

6.3 Cartelas

6.4 Conector

6.5 Difusor

6.6 Tira LED

6.7 Conductor
adhesivo

6.8 Barra



BARRAS



CARGA LIGERA

4901/1..

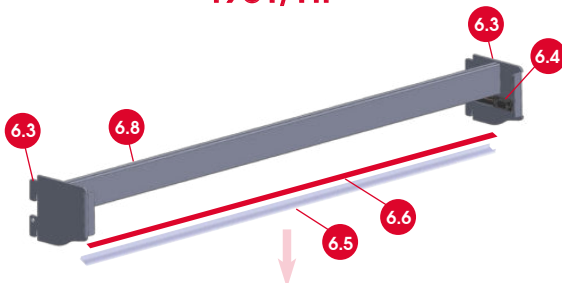

4910/1..

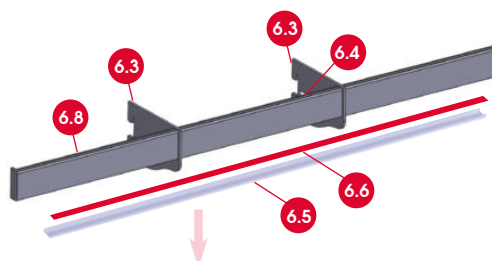

CARGA MEDIA

3898/1..

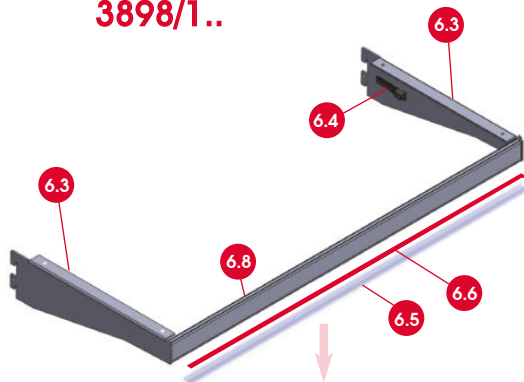

3897/1..

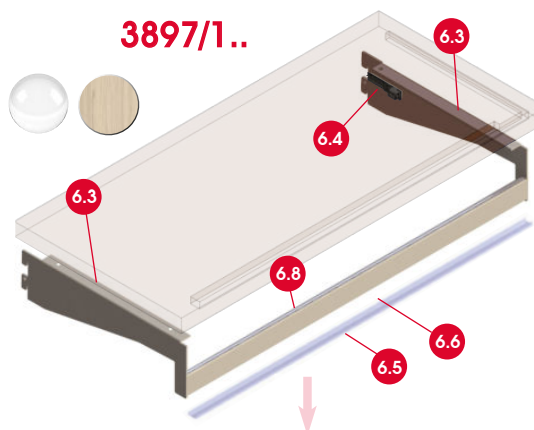



ESTANTES

Tira LED

Orientación
de la luz



CARGA LIGERA

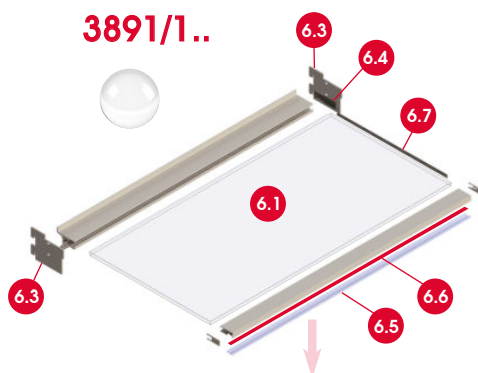

CARGA MEDIA

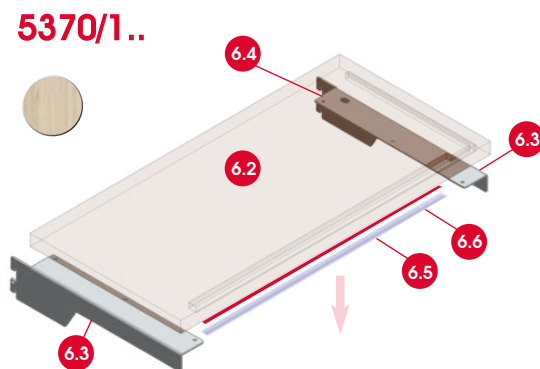
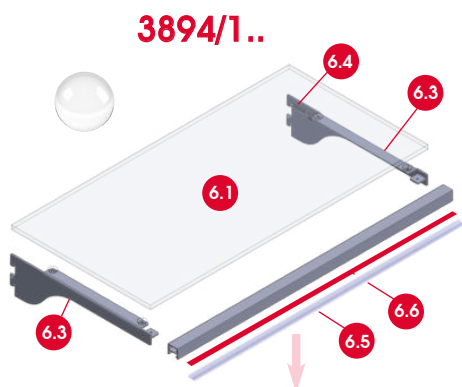

CARGA ALTA

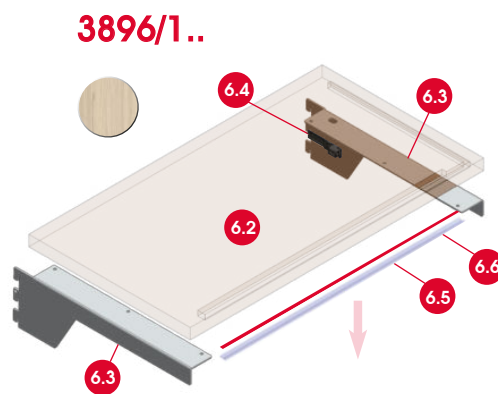
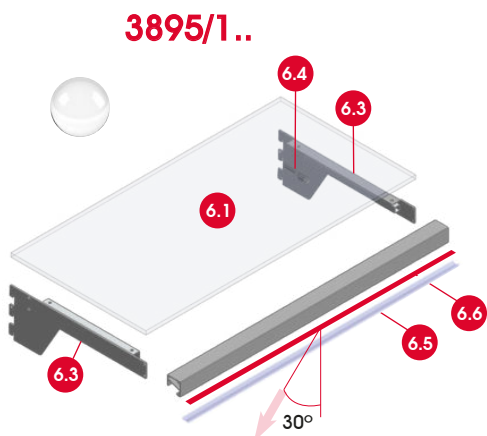



COMPONENTES POR PIEZA/METRO

CREMALLERAS

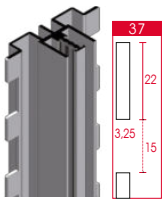

**GUÍA ELECTRIFICABLE
PANELABLE - 2 CANALES**
CRÉMAILLÈRE ÉLECTRIFIABLE
AVEC DOUBLE PERFORATION
ELECTRIFIABLE DOUBLE SLOT
RACK
CREMAGLIERA ELETRIFICABILE
CON FORATURA DOPPIA
4870/1... 5M
4870/57... 5.7M

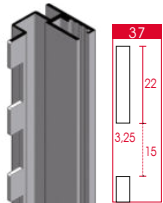
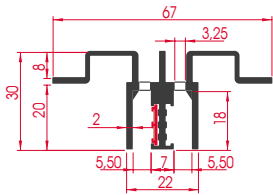

**GUÍA ELECTRIFICABLE
PANELABLE - 1 CANAL**
CRÉMAILLÈRE ÉLECTRIFIABLE
AVEC SINGLE PERFORATION
ELECTRIFIABLE SINGLE SLOT
RACK
CREMAGLIERA ELETRIFICABILE
CON FORATURA SEMPLICE
4872/1... 5M
4872/57... 5.7M

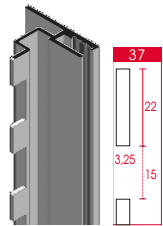
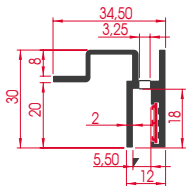

**GUÍA ELECTRIFICABLE
PANELABLE - 1 CANAL - FINAL**
CRÉMAILLÈRE ÉLECTRIFIABLE
FINAL AVEC SINGLE
PERFORATION
FINAL ELECTRIFIABLE SINGLE
SLOT RACK
CREMAGLIERA ELETRIFICABILE
FINALE CON FORATURA
SEMPLICE
4874/1...

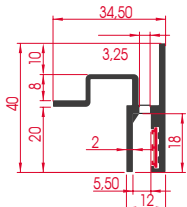

CONECTORES



**NUEVO CONECTOR
PLUG & PLAY. BLANCO**
CONNECTEUR PLUG & PLAY,
BLANC
CONNECTOR PLUG & PLAY,
WHITE
CONNETTORE PLUG & PLAY,
BIANCO
84880/NOB
84880/NON

PL. M	BLANCO	NEGRO	COLOR
ALU. M	BLANC	NOIR	COULEUR
ALL. NAT	BIANCO	NERO	COLORE
01	0B	0N	0P

Al	5 m - 5,7 m	67x30	€/m

Al	5 m - 5,7 m	35x30	€/m

Al	5 m	35x40	€/m

Pla	3 m	24 W	€/u

Plástico	Plástico	Plástico	Plástico
PLASTIC	PLASTIC	PLASTIC	PLASTIC
PLASTICA	PLASTICA	PLASTICA	PLASTICA
09			

CARRIL ELECTRIFICADO



**CARRIL ELECTRIFICADO SIN CABLE
CONEXIÓN A DRIVER (1M)**
4871/109 1M

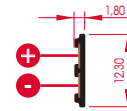

**CABLE CON MINI-CONECTORES
230V**
CABLE + MINI PLUG - 230V
CABLE + MINI PLUG - 230V
CAVO + MINI PLUG - 230V
6015/00B

Cable para soldar al carril 4871/109.
CONEXIÓN CON DRIVER 6010

ZINCADO	INOX	SAT	PLÁSTICO
PL. ZINC	INOX	SAT	PLASTIC
ZINCATO	INOX	SAT	PLASTICA
34	28	09	

Max. 6A	25m	€/m

Pla	3 m	230 V	€/u

GRAPAS



**PANELES
19MM GROSOR**

**ENGANCHE PARA COLGAR PANELES -
19MM GROSOR**
CROCHET POUR ACCROCHER
PANNEAUX -19MM
HOOK FOR HANGING PANELS -19MM
GANCIO PER APPENDERE PANNELI
-19MM
4616/034

Fe	4870-4874	€/u



**PANELES
10MM GROSOR**

**ENGANCHE PARA COLGAR PANELES
-10MM GROSOR**
CROCHET POUR ACCROCHER
PANNEAUX - 10MM
HOOK FOR HANGING PANELS -
10MM
GANCIO PER APPENDERE PANNELI
-10MM
4635/034

Fe	4870-4874	€/u



**PANELES
10MM GROSOR**

**CLIPAJE PARA ENCASTRAR PANELES
FRONTALMENTE**
CLIPPING POUR ADAPTER LES
PANNEAUX FRONTALEMENT
CLIPPING TO FIT PANELS FRONTALLY
CLIPPING PER ADATTARE I PANNELI
FRONTALMENTE
4607/028

Fe	4870-4874	€/u

CABLES



CABLE MINI PLUG - ABIERTO 24V
CABLE MINI PLUG - OVERTE 24V
CABLE MINI PLUG - OPEN ENDED 24V
CAVO MINI PLUG - APERTO 24V
4888/009

Pla	400 m	24 V	€/u



SISTEMA DE FÁCIL CONEXIÓN - PLUG & PLAY

DRIVER

PLÁSTICO
PLASTIQUE
PLASTIC
PLASTICA
09



6 SALIDAS

DRIVER 100W, 24V /
CONECTOR HEMBRA
CONDUCTEUR 100W, 24V /
CONNECTEUR FEMELLE
DRIVER 100W, 24V /
FEMALE CONNECTOR
DRIVER 100W, 24V /
CONNETTORE FEMMINA
6010/009

Pla	⚡ 24V 100W	€/u
	15cm	

CABLE CON MINI-CONECTORES
230V
CABLE + MINI PLUG - 230V
CABLE + MINI PLUG - 230V
CAVO + MINI PLUG - 230V
6015/00B



Pla	⚡ 230 V	€/u
	3 m	2,5 A

CONECTOR DIVER 6 VIAS 20CM
CONNECTEUR PLONGEUR 6
VOIES 20CM
6-WAY DIVER CONNECTOR
20CM
CONNETTORE SUBACQUEO A 6
VIE 20 CM
6021/009



Pla	⚡ 230 V	€/u
	3 m	2,5 A

CABLE ALARGO MACHO-HEMBRA 3M
CÂBLE D'EXTENSION MÂLE-FEMELLE DE
3 M
3M MALE-FEMALE EXTENSION CABLE
CAVO DI PROLUNGA
MASCIO-FEMMINA 3M
6022/00B



Pla	⚡ 230 V	€/u
	3 m	2,5 A

CON CONECTOR NUEVO



SISTEMA CUT-LINE

PL. M.
ALU. M.
ALU. M.
ALL. NAT.
01

DIFERENTES
POSICIONES
DEL DIFUSOR
(RECTO /
INCLINADO)



PERFIL DE ALUMINIO CON LED
INCORPORADO
PROFILÉ EN ALUMINIUM AVEC LED
INTÉGRÉE
ALUMINIUM PROFILE WITH BUILT-IN LED
PROFILO IN ALLUMINIO CON LED
INTEGRATO
6025/301 4000K
6026/301 5000K

Pla	⚡ 230 V	€/u
	3 m	
	⊗ CRI > 90	
	9,6W/24V	€/u



SET CONECTOR + TAPA
CABLE 40CM
6030/041

GRAPAS
6031/041

○
○

○

○

SISTEMA DE PERFIL DE ALUMINIO CON LED INCORPORADO

SE PUEDE ENCASTRAR A LA MADERA
O AUTOADHESIVAR

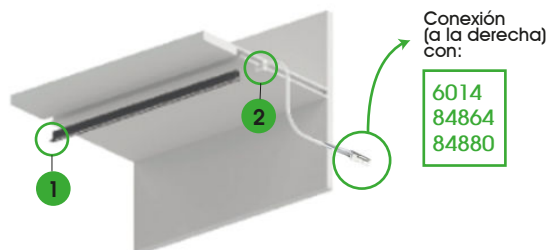

Conexión
(a la derecha)
con:

6014
84864
84880

CARRIL ELECTRIFICADO



Longitud
cable
1m.

Gesis®
GST0812G

CARRIL ELECTRIFICADO + CABLE
CONEXIÓN A DRIVER (1M)
VOIE ÉLECTRIFIÉE + CÂBLE DE
CONNEXION A DRIVER (1M)
ELECTRIFIED TRACK + CONNECTION
WIRE TO DRIVER (1M)
BINARIO ELETTRIFICATO + CAVO
CONNESSIONE DRIVER (1M)
4871/259 2.5M
4871/159 1.5M

Fe	⊙ 4870- 4872 - 4874	€/u
----	------------------------	-----

○
○

CORTE TOTALMENTE LIBRE, SIN LIMITES DE MEDIDAS

SE CORTA TODA LA ESTRUCTURA Y EL LED
A LA MEDIDA DESEADA Y SE REMATA
CON LOS TAPONES FINALES POR AMBOS LADOS



1 Tapón simple / 2 Tapón con conexión (derecha)

DISTINTAS MANERAS DE POSICIONAR EL LED

SEGÚN NECESIDAD DE DIRECCIONAR LA LUZ

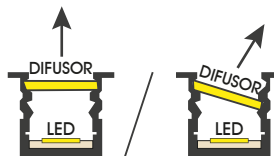

Cualquier
manipulación invalida
la garantía del
fabricante





ESTANTE

VIDRIO 3895/1..

* Recomendamos usar vidrios asegurados o laminados. (NO INCLUIDO)

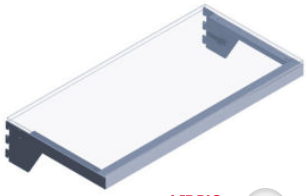

**VIDRIO *
NO INCLUIDO**

**ESTANTE DE VIDRIO
CON ILUMINACIÓN
FRONTAL
3895/1..
MONTADO**

Étagère en verre avec éclairage avant
Glass shelf with front lighting
Ripiano vetro con illuminazione frontale

1M máx.
29 cm

PL. M	BLANCO	NEGRO	COLOR
ALU. M	BLANC	NOIR	COULEUR
ALL. NAT	WHITE	BLACK	COLOR
	BIANCO	NERO	COLORE
01	OB	ON	OP

ESTANTE

VIDRIO 3894/1..

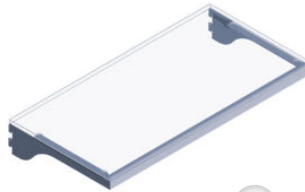

**VIDRIO *
NO INCLUIDO**

**ESTANTE DE VIDRIO
CON ILUMINACIÓN
CENTRAL FRONTAL
3894/1..
MONTADO**

Étagère en verre avec éclairage zenithal frontal
Glass shelf with front zenithal lighting
Ripiano di vetro con illuminazione zenitale frontale

1M máx.
29 cm

PLÁSTICO	BLANCO	NEGRO	COLOR
PLASTIQUE	BLANC	NOIR	COULEUR
PLASTIC	WHITE	BLACK	COLOR
PLASTICA	BIANCO	NERO	COLORE
09	OB	ON	OP

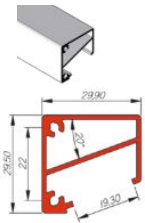

**PERFIL ALUMINIO
PROFIL EN ALUMINIUM
ALUMINIUM PROFILE
PROFILO DI ALUMINIO
4744/1..**

Al	5 m	30x30	€/m
Ⓞ 84602			

PLÁSTICO	BLANCO	NEGRO	COLOR
PLASTIQUE	BLANC	NOIR	COULEUR
PLASTIC	WHITE	BLACK	COLOR
PLASTICA	BIANCO	NERO	COLORE

09	OB	ON	OP
----	----	----	----



**DIFUSOR PLASTICO MATE
DIFFUSEUR EN PLASTIQUE MAT
MATT PLASTIC DIFFUSOR
DIFUSORE PLASTICO OPACO
84602/109**

Pla	2 m	Ⓞ 4744	€/m
-----	-----	--------	-----

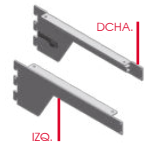

Cada cartela tiene 2 taladros para usar 1 perfil 4744

Kit 2 cartelas: DERECHA (con conector) + IZQUIERDA

**KIT CARTELAS ESTANTE VIDRIO
CON ILUMINACIÓN
KIT SUPPORTS VERRE
ILUMINATION
GLASS LIGHTING BRACKETS KIT
KIT MENSOLE VETRO
ILLUMINAZIONE
4880/0..**

Fe	Ⓞ 4744-2556-4890	€/u
292 mm medida útil		



126 diodos (20λ); cortable cada 5,5 cm
Cable, fil. wire, cavo: 26cm
Ancho 8mm

flexible y con cinta adhesiva
fleible and self-adhesive

**LED CON
MINI-CONECTOR 24V
BANDE LED AVEC
MINI-PLUG 24V
LED STRIP WITH
MINI-PLUG 24V
STRACIA LED CON
MINI-PLUG 24V
4890/109**

Pla	1 m	⚡ 5000 K	€/u
☑ CRI > 90 ⬢ 9,6 W 24V			

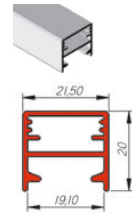

**PERFIL ALUMINIO
PROFIL EN ALUMINIUM
ALUMINIUM PROFILE
PROFILO DI ALUMINIO
4748/1..**

Al	6 m	21,5x20	€/m
Ⓞ 4893			

09	OB	ON	OP
----	----	----	----



**DIFUSOR PLASTICO MATE
DIFFUSEUR EN PLASTIQUE MAT
MATT PLASTIC DIFFUSOR
DIFUSORE PLASTICO OPACO
4893/109**

Pla	2 m	Ⓞ 4748	€/m
-----	-----	--------	-----



Kit 2 cartelas: DERECHA (con conector) + IZQUIERDA

**KIT CARTELAS ESTANTE VIDRIO
CON ILUMINACIÓN
KIT SUPPORTS VERRE
ILUMINATION
GLASS LIGHTING BRACKETS KIT
KIT MENSOLE VETRO
ILLUMINAZIONE
4891/0..**

Fe	Ⓞ 4744-2556-4890	€/u
292 mm medida útil		



126 diodos (20λ); cortable cada 5,5 cm
Cable, fil. wire, cavo: 26cm
Ancho 8mm

flexible y con cinta adhesiva
fleible and self-adhesive

**LED CON
MINI-CONECTOR 24V
BANDE LED AVEC
MINI-PLUG 24V
LED STRIP WITH
MINI-PLUG 24V
STRACIA LED CON
MINI-PLUG 24V
4890/109**

Pla	1 m	⚡ 5000 K	€/u
☑ CRI > 90 ⬢ 9,6 W 24V			



**VENTOSA TRANSPARENTE
VENTOUSE
SUCTION
VENTOSA
2556/009**

Pla	∅14 mm	Ⓞ 4880	€/u
-----	--------	--------	-----



**VENTOSA TRANSPARENTE
VENTOUSE
SUCTION
VENTOSA
2556/009**

Pla	∅14 mm	Ⓞ 4891	€/u
-----	--------	--------	-----



ESTANTE

VIDRIO 3890/1..

* Recomendamos usar vidrios segurizados o laminados. (NO INCLUIDO)



VIDRIO *
NO INCLUIDO

ESTANTE DE VIDRIO

RETROILUMINADO

*3890/1..

MONTADO

Étagère en verre extra
claire rétro-éclairé
Blacklit optical glass shelf
Ripiano vetro extralight
retroilluminato

1M máx.
30
cm

€/u

PL M	BLANCO	NEGRO	COLOR
ALU. M	BLANC	NOIR	COULEUR
ALL. NAT	WHITE	BLACK	COLOR
	BANCO	NERO	COLORE
01	0B	0N	0P

ESTANTE

VIDRIO 3891/1..



VIDRIO *
NO INCLUIDO

ESTANTE DE

VIDRIO CON

ILUMINACIÓN

FRONTAL

*3891/1..

MONTADO

Étagère en verre avec
éclairage zénithal frontal
Glass shelf with frontal
zenithal lighting
Ripiano di vetro con
illuminazione zenitale
frontale

1M máx.
30
cm

€/u

PL M	BLANCO	NEGRO	COLOR
ALU. M	BLANC	NOIR	COULEUR
ALL. NAT	WHITE	BLACK	COLOR
	BANCO	NERO	COLORE
01	0B	0N	0P



junta goma incluida
joint en caoutchouc
inclus rubber gasket
included giunta di
gomma inclusa

PERFIL ALUMINIO

PROFIL LAME

D'ALUMINIUM

ALUMINIUM SLATWALL

PROFILE

PROFILO DOGATO

ALLUMINIO

*362/1...

Al	5 m	6-8mm	€/m
361/109			

*o *o *o *o

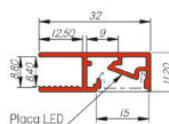
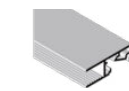

PERFIL ALUMINIO

PROFIL EN ALUMINIUM

ALUMINIUM PROFILE

PROFILO DI ALLUMINIO

4892/1..

Al	5 m	32x11,2	€/m
4893 -4894			

o o o o



Para perfil 362
Kit 2 cartelas:
DERECHA (con
conector) +
IZQUIERDA

KIT CARTELAS ESTANTE

VIDRIO CON

ILUMINACIÓN

KIT SUPPORTS VERRE

ILUMINATION

GLASS LIGHTING

BRACKETS KIT

KIT MENSOLE VETRO

ILLUMINAZIONE

*386/0..

Fe	362 - 4890	€/u
68 mm medida útil		

*o *o *o



DIFUSOR DE PLÁSTICO MATE

DIFFUSEUR EN PLASTIQUE MAT

MATT PLASTIC DIFUSOR

DIFUSORE PLASTICO OPACO

4893/109

Pla	4892 -4894	€/m
2 m		

o



126 diodos (20λ);
cortable cada
5,5 cm
Cable, fil, wire,
cavo: 26cm
Ancho 8mm

flexible y con
cinta adhesiva
fleible and
self-adhesive

LED CON

MINI-CONECTOR 24V

BANDE LED AVEC

MINI-PLUG 24V

LED STRIP WITH

MINI-PLUG 24V

STRACIA LED CON

MINI-PLUG 24V

4890/109

Pla	1 m	5000 K	€/u
CRI>90	9,6 W	24V	

o

PLÁSTICO
PLASTIQUE
PLASTIC
PLASTICA
09

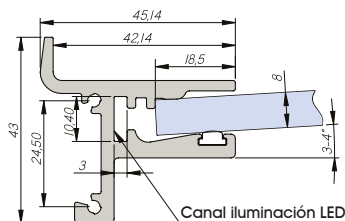

Canal iluminación LED

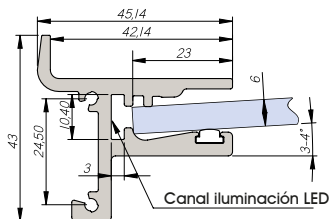

Canal iluminación LED

• MÁXIMA
MEDIDA ESTANTE
RECOMENDADA:
100 X 30 CM.

• Maximum
recommended
shelf size: 100 x
30 cm.

• Dimensione
massima
raccomandata
dello scaffale:
100 x 30 cm.

• Taille
maximale de
l'étagère
recommandée:
100 x 30 cm.



ESTANTE

MADERA 3896/1..

* MADERA NO INCLUIDA

PL. M	BLANCO	NEGRO	COLOR
ALU. M	BLANC	NOR	COULEUR
ALU. M	WHITE	BLACK	COLOR
ALL. NAT	BIANCO	NERO	COLORE
01	0B	0N	0P

ESTANTE DE MADERA CON ILUMINACIÓN FRONTAL EMPOTRADA Y PERFIL DE ALUMINIO (3971)

3896/1..

SIN MONTAJE

Étagère en bois avec éclairage zénithal monté sur l'étagère
Wooden shelf with zenithal lighting mounted on the shelf
Ripiano legno con illuminazione zenitale impotrata nel ripiano

1M máx.
35 cm

€/u



MADERA NO INCLUIDA

ESTANTE

MADERA 5370/1..

PL. M	BLANCO	NEGRO	COLOR
ALU. M	BLANC	NOR	COULEUR
ALU. M	WHITE	BLACK	COLOR
ALL. NAT	BIANCO	NERO	COLORE
01	0B	0N	0P

ESTANTE DE MADERA CON ILUMINACIÓN FRONTAL EMPOTRADA Y PERFIL DE ALUMINIO (3971)

*5370/1..

SIN MONTAJE

Étagère en bois avec éclairage zénithal monté sur l'étagère
Wooden shelf with zenithal lighting mounted on the shelf
Ripiano legno con illuminazione zenitale impotrata nel ripiano

1M máx.
29 cm

€/u



MADERA NO INCLUIDA *

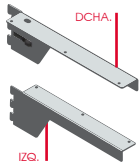

KIT CARTELAS ESTANTE MADERA CON ILUMINACIÓN
KIT SUPPORTS BOIS ILUMINATION
WOOD LIGHTING BRACKETS KIT
KIT MENSOLE LEGNO ILLUMINAZIONE

4885/0..

Fe	4890	€/u
350 mm medida útil		

Kit 2 cartelas: DERECHA (con conector) + IZQUIERDA



KIT PERFIL ALUMINIO CON DIFUSOR
KIT PROFIL EN ALUMINIUM AVEC DIFFUSEUR
KIT PROFILO IN ALLUMINIO CON DIFFUSORE

3971/1..

Al	2 m	18x9	€/m
----	-----	------	-----

Fresar la madera e insertar

Medidas mecanizado 16 x 6.8 mm



LED CON MINI-CONECTOR 24V
BANDE LED AVEC MINI-PLUG 24V
LED STRIP WITH MINI-PLUG 24V
STRACIA LED CON MINI-PLUG 24V

4890/009

Pla	1 m	5000 K	€/u
CRI > 90 9,6 W 24V			

126 diodos (20λ); cortable cada 5,5 cm
Cable, fil, wire, cavo: 40cm
Ancho 8 mm
flexible y con cinta adhesiva flexible and self-adhesive

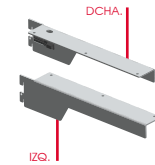

KIT CARTELAS ESTANTE MADERA CON ILUMINACIÓN
KIT SUPPORTS BOIS ILUMINATION
WOOD LIGHTING BRACKETS KIT
KIT MENSOLE LEGNO ILLUMINAZIONE

*5370/0..

Fe	4890	€/u
290 mm medida útil		

Kit 2 cartelas: DERECHA (con conector) + IZQUIERDA



KIT PERFIL ALUMINIO CON DIFUSOR
KIT PROFIL EN ALUMINIUM AVEC DIFFUSEUR
KIT PROFILO IN ALLUMINIO CON DIFFUSORE

3971/1..

Al	2 m	18x9	€/m
----	-----	------	-----

Fresar la madera e insertar

Medidas mecanizado 16 x 6.8 mm



LED CON MINI-CONECTOR 24V
BANDE LED AVEC MINI-PLUG 24V
LED STRIP WITH MINI-PLUG 24V
STRACIA LED CON MINI-PLUG 24V

4890/009

Pla	1 m	5000 K	€/u
CRI > 90 9,6 W 24V			

126 diodos (20λ); cortable cada 5,5 cm
Cable, fil, wire, cavo: 40cm
Ancho 8 mm
flexible y con cinta adhesiva flexible and self-adhesive

SISTEMA CUT-LINE

PL. M	BLANCO	NEGRO	COLOR
ALU. M	BLANC	NOR	COULEUR
ALU. M	WHITE	BLACK	COLOR
ALL. NAT	BIANCO	NERO	COLORE
01			



PERFIL DE ALUMINIO CON LED INCORPORADO
PROFILÉ EN ALUMINIUM AVEC LED INTÉGRÉE
ALUMINUM PROFILE WITH BUILT-IN LED INTEGRATO

6025/301 4000K
6026/301 5000K

SET CONECTOR + TAPA
CABLE 40CM
6030/041

GRAPAS
6031/041

Pla	3 m	€/u
CRI > 90 9,6 W 24V		

DIFERENTES POSICIONES DEL DIFUSOR (RECTO / INCLINADO)



SISTEMA DE PERFIL DE ALUMINIO CON LED INCORPORADO

SE PUEDE ENCASTRAR A LA MADERA O AUTOADHESIVAR

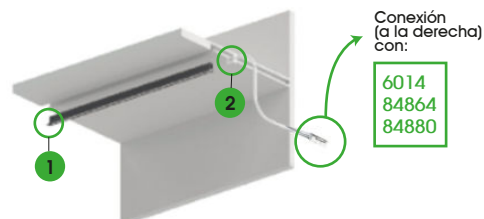

Conexión (a la derecha) con:

6014
84864
84880

CORTE TOTALMENTE LIBRE, SIN LIMITES DE MEDIDAS

SE CORTA TODA LA ESTRUCTURA Y EL LED A LA MEDIDA DESEADA Y SE REMATA CON LOS TAPONES FINALES POR AMBOS LADOS





**BARRA ACCESORIOS
FRONTAL 4910/1..**

PL. M ALU. M ALL. NAT	BLANCO BLANC WHITE BIANCO	NEGRO NOR BLACK NERO	COLOR COULEUR COLOR COLORE
01	0B	0N	0P

CARGA LIGERA



Kit compuesto por:
- Cartelas Ref.4875
-Tubo rectangular
Ref.4900/10B
-LED de 1m

1M máx.
8 cm

BARRA DE CUELGUE PARA
ACCESORIOS FRONTALES CON
ILUMINACIÓN Y PROTECCIÓN
PLÁSTICA

4910/1..

MONTADO
Barre de suspension pour
accessoires avant avec
éclairage
Hanger bar for front
accessories with lighting
Barra appendiabili per
accessori frontali con
illuminazione

€/u

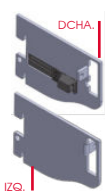

Kit 2 cartelas:
DERECHA (con
conector) +
IZQUIERDA

**KIT CARTELAS BARRA
ACCESORIOS**
KIT SUPPORT BARRE
ACCESSOIRES
KIT BRACKET FOR
ACCESSORIES ROD
KIT MENSOLA TUBO
PORTA-ACCESSORI

4875/00.

Fe	⊙4900	€/u
	81 mm medida útil	

o o o

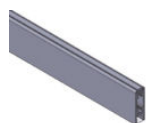

LED no incluido.
LED
recomendado de
5mm de ancho.
Incluye perfil de
plástico superior y
difusor interior.

**TUBO RECTANGULAR PARA
ILUMINACIÓN 30X10MM
CON PLETINA DE REFUERZO**
KIT TUBE RECTANGULAIRE
POUR ECLAIRAGE 30X10MM
AVEC PLAQUE DE RENFORT
KIT RECTANGULAR TUBE FOR
LIGHTING 30X10MM WITH
REINFORCING PLATE
KIT TUBO RETTANGOLARE PER
ILLUMINAZIONE 30X10MM
CON PIASTRA DI RINFORZO

4900/12.

Al	⊔ 1 m	30x10	€/u
	⊙4901/109		

o o o o



Para perfil
4900

**TAPA PARA TUBO
RECTANGULAR 30X10MM**
CAPUCHON DE TUBE
RECTANGULAIRE
30X10MM TUBE CAP
RECTANGULAR 30X10MM
TAPPO DEL TUBO
RETTANGOLARE 30X10MM

4904/0..

Fe	92 mm	⊙4900	€/u
----	-------	-------	-----

o o o o

PLÁSTICO
PLASTIQUE
PLASTIC
PLASTICA
09



182 diodos (20λ);
cortable cada
3.8 cm
Cable, fil. wire,
cavo: 40cm
Ancho 5mm

flexible y con
cinta adhesiva
fleible and
self-adhesive

LED CON MINI-CONECTOR 24V
BANDE LED AVEC MINI-PLUG
24V
LED STRIP WITH MINI-PLUG 24V
STRACIA LED CON MINI-PLUG
24V

4910/109

Pla	⊔ 1 m	⚡ 5000 K	€/u
	⊙CRI>90	⊙15,3W 24V	

o

**BARRA ACCESORIOS
FRONTAL 4901/1..**

PL. M ALU. M ALL. NAT	BLANCO BLANC WHITE BIANCO	NEGRO NOR BLACK NERO	COLOR COULEUR COLOR COLORE
01	0B	0N	0P

CARGA LIGERA

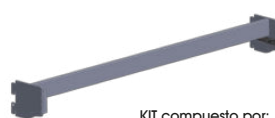

Kit compuesto por:
- Cartelas Ref.4878
-Tubo rectangular
Ref.4900/10B
-LED de 1m

1M máx.
7 cm

BARRA DE CUELGUE PARA
ACCESORIOS FRONTALES
CON ILUMINACIÓN Y
PROTECCIÓN PLÁSTICA
SUPERIOR

4901/1..

MONTADO
Barre de suspension pour
accessoires avant avec éclairage
Hanger bar for front accessories
with lighting
Barra appendiabili per accessori
frontali con illuminazione

€/u

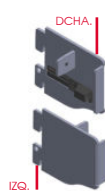

Kit 2 cartelas:
DERECHA (con
conector) +
IZQUIERDA

KIT CARTELAS BARRA ACCESORIOS
KIT SUPPORT BARRE ACCESSOIRES
KIT BRACKET FOR
ACCESSORIES ROD
KIT MENSOLA TUBO
PORTA-ACCESSORI

4878/00.

Fe	⊙4900	€/u
	68 mm medida útil	

o o o

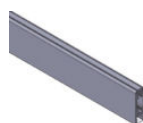

LED no incluido.
LED
recomendado de
5mm de ancho.
Incluye perfil de
plástico superior y
difusor interior.

**TUBO RECTANGULAR PARA
ILUMINACIÓN 30X10MM
CON PLETINA DE REFUERZO**
KIT TUBE RECTANGULAIRE
POUR ECLAIRAGE 30X10MM
AVEC PLAQUE DE RENFORT
KIT RECTANGULAR TUBE FOR
LIGHTING 30X10MM WITH
REINFORCING PLATE
KIT TUBO RETTANGOLARE PER
ILLUMINAZIONE 30X10MM
CON PIASTRA DI RINFORZO

4900/12.

CON ALMA DE
ACERO INOX

CARGA LIGERA
max. 30KG

Al	⊔ 1 m	30x10	€/u
	⊙4901/109		

o o o o



182 diodos (20λ);
cortable cada
3.8 cm
Cable, fil. wire,
cavo: 45 mm
Ancho 5mm

flexible y con
cinta adhesiva
fleible and
self-adhesive

LED CON MINI-CONECTOR 24V
BANDE LED AVEC MINI-PLUG 24V
LED STRIP WITH MINI-PLUG 24V
STRACIA LED CON MINI-PLUG
24V

4901/109

Pla	⊔ 1 m	⚡ 5000 K	€/u
	⊙CRI>90	⊙15,3W 24V	

PLÁSTICO
PLASTIQUE
PLASTIC
PLASTICA
09

o

EJEMPLO DE APLICACIÓN

Barras de
accesorios con
carga frontal.

**NO APTO PARA
PERROQUET
SOLO GANCHO**

CARGA LIGERA

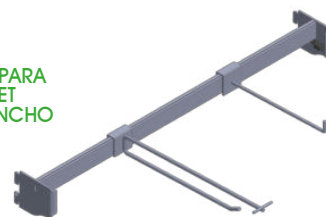



PENDERIE 3897/1..

- * MADERA NO INCLUIDA
- * Recomendamos usar vidrios asegurizados o laminados. (NO INCLUIDO)

CARGA LIGERA



VIDRIO / MADERA
NO INCLUIDO



ESTANTE + BARRA DE
CUELQUE LATERAL CON
ILUMINACIÓN Y
PROTECCIÓN PLÁSTICA
SUPERIOR
3897/1..

MONTADO

Tablette + barre de suspension
latérale avec éclairage
Shelf + side hanging bar with lighting
Mensola + barra appendiabiti
laterale con illuminazione

1M máx.
29
cm

PARA MADERA
O VIDRIO

PL. M ALU. M ALL. M ALL. NAT	BLANCO BLANC WHITE BIANCO	NEGRO NOR BLACK NERO	COLOR COULEUR COLOR COLORE
01	0B	0N	0P

BARRA DE CUELQUE LATERAL 3898/1..

CARGA LIGERA



BARRA DE CUELQUE
LATERAL CON ILUMINACIÓN
Y PROTECCIÓN PLÁSTICA
SUPERIOR
3898/1..

MONTADO

Barre de suspension
latérale avec éclairage
Side hanger bar with
lighting
Barra appendiabiti
laterale con illuminazione

1M máx.
29
cm

PL. M ALU. M ALL. M ALL. NAT	BLANCO BLANC WHITE BIANCO	NEGRO NOR BLACK NERO	COLOR COULEUR COLOR COLORE
01	0B	0N	0P

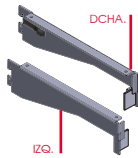

Kit 2 cartelas:
DERECHA (con
conector) +
IZQUIERDA

**KIT CARTELAS BARRA CUELQUE
CON ESTANTE**
KIT SUPPORT BARRE
ACCESSOIRES
KIT BRACKET FOR
ACCESSORIES ROD
KIT MENSOLA TUBO
PORTA-ACCESSORI
4727/0..

Fe	⊙ 4900	€/u
	290 mm medida útil	

Al	⊔ 1 m	30x10	€/u
	⊙ 4901		

**TUBO RECTANGULAR PARA
ILUMINACIÓN 30X10MM
CON PLETINA DE REFUERZO**
KIT TUBE RECTANGULAIRE POUR
ECLAIRAGE 30X10MM AVEC
PLAQUE DE RENFORT
KIT RECTANGULAR TUBE FOR
LIGHTING 30X10MM WITH
REINFORCING PLATE
KIT TUBO RETTANGOLARE PER
ILLUMINAZIONE 30X10MM
CON PIASTRA DI RINFORZO
4900/12.

**CON ALMA DE
ACERO INOX**

CARGA LIGERA
max. 30KG

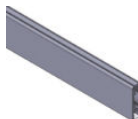

LED no incluido.
LED
recomendado de
5mm de ancho.
Incluye perfil de
plástico superior y
difusor interior.



182 diodos (20λ);
cortable cada
3.8 cm
Cable, fil, wire,
cavo: 40cm
Ancho 5mm

flexible y con
cinta adhesiva
fleible and
self-adhesive

**LED CON MINI-CONECTOR
24V**
BANDE LED AVEC MINI-PLUG
24V
LED STRIP WITH MINI-PLUG
24V
STRIACIA LED CON
MINI-PLUG 24V
4910/109

Pla	⊔ 1 m	⚡ 5000 K	€/u
	⊙ CRI > 90	⊖ 15,3W 24V	

PLÁSTICO
PLASTIQUE
PLASTIC
PLASTICA
09

**VENTOSA TRANSPARENTE
VENTOUSE
SUCITON
VENTOSA
2556/009**



Pla	⊙ 14 mm	⊙ 4726	€/u
-----	---------	--------	-----

**PERFIL DE ALUMINIO CON
LED INCORPORADO**
PROFILÉ EN ALUMINIUM
AVEC LED INTÉGRÉE
ALUMINIUM PROFILE WITH
BUILT-IN LED
PROFILO IN ALLUMINIO
CON LED INTEGRATO
6025/301 4000K
6026/301 5000K

DIFERENTES
POSICIONES
DEL DIFUSOR
(RECTO /
INCLINADO)

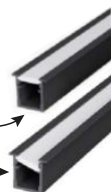

Pla	⊔ 3 m	€/u
	⊙ CRI > 90	⊖ 9,6W 24V

**SET CONECTOR + TAPA
CABLE 40CM**
6030/041



GRAPAS
6031/041



PERROQUET

4725/0..

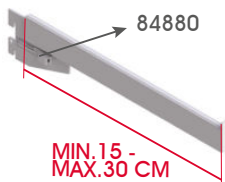

PERROQUET PLANO CON
ILUMINACIÓN PARA
CUELGUE FRONTAL

4725/0..

MONTADO

Chien plat avec éclairage
pour suspension avant
Flat doggie with lighting
for front hanging
Cagnolino piatto con
illuminazione per
sospensione frontale

Fe 300 mm

PL. M	BLANCO	NEGRO	COLOR
ALU. M	BLANC	NOR	COULEUR
ALL. NAT	WHITE	BLACK	COLOR
	BANCO	NERO	COLORE
01	0B	0N	0P

€/u

CARTELAS

4636/0..



ESTANTE VOLADO DE
MADERA CON ILUMINACIÓN
DE GROSOR 19MM

KIT CARTELAS
4636/1..

SIN MONTAJE

Étagère en bois avec
éclairage, épaisseur 19 mm
Wooden shelf with lighting,
19mm thick
Mensola in legno con
illuminazione, spessore 19
mm

MADERA *
NO INCLUIDA

Fe 3971

PL. M	BLANCO	NEGRO	COLOR
ALU. M	BLANC	NOR	COULEUR
ALL. NAT	WHITE	BLACK	COLOR
	BANCO	NERO	COLORE
01	0B	0N	0P

€/u

SISTEMA CUT-LINE

DIFERENTES
POSICIONES
DEL DIFUSOR
(RECTO /
INCLINADO)

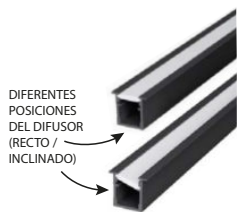

PERFIL DE ALUMINIO CON LED
INCORPORADO
PROFILÉ EN ALUMINIUM AVEC LED
INTÉGRÉE
ALUMINIUM PROFILE WITH BUILT-IN LED
PROFILO IN ALLUMINIO CON LED
INTEGRATO

6025/301 4000K
6026/301 5000K



SET CONECTOR + TAPA
CABLE 40CM
6030/041

GRAPAS
6031/041

PL. M
ALU. M
ALL. NAT
01

Pla 3 m
CRI > 90
9,6W24V €/u

€/u

SISTEMA DE PERFIL DE ALUMINIO CON LED
INCORPORADO

SE PUEDE ENCASTRAR A LA MADERA O AUTOADHESIVAR

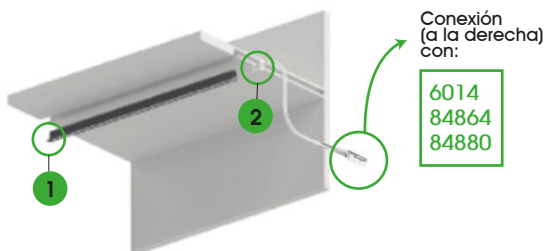

Conexión
(a la derecha)
con:

6014
84864
84880

CORTE TOTALMENTE LIBRE, SIN LIMITES DE MEDIDAS

SE CORTA TODA LA ESTRUCTURA Y EL LED A LA MEDIDA DESEADA
Y SE REMATA CON LOS TAPONES FINALES POR AMBOS LADOS



1 Tapón simple / 2 Tapón con
conexión
(derecha)



Kit 2 cartelas:
DERECHA (con
conector) +
IZQUIERDA



Fresar la
madera
e insertar

Medidas
mecanizado
16 x 6.8 mm



LED CON MINI-CONECTOR
24V
BANDE LED AVEC MINI-PLUG
24V
LED STRIP WITH MINI-PLUG
24V
STRACIA LED CON
MINI-PLUG 24V
4890/109



CARTELA DER

Kit 2 cartelas 4636
DER. - Con conector
IZQ. - Sin conector

Fe 4890
350 mm medida útil
€/u

Al 2 m 18x9 €/m

Pla 1 m 5000 K €/u
CRI > 90 9,6 W 24V

PLÁSTICO
PLASTIQUE
PLASTIC
PLASTICA
09

€/u



KADÍ PHARMA - ELEKTRIC





INSTAL
ILUMINACIÓN



KADÍ ELEKTRIC
PHARMA C.209



ESCANEA ESTE QR
PARA VER TODAS
LAS IMÁGENES DEL
SISTEMA PHARMA



KADÍ
PHARMA
ELEKTRIC

Ejemplos orientativos
de distintas posibilidades,
distribuciones y
aplicaciones



EXPLOSIONADO GENERAL



MONTAJE EN SERIE

Colocar las cremalleras **ELECTRIFICADAS** EN EL LADO DERECHO de cada panel

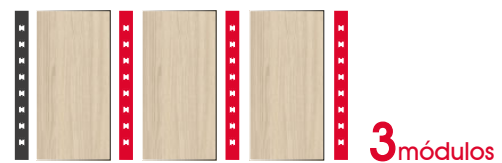

REF: 4786
+ 4862 (CARRIL ELEKTRIC)

Tubos
electrificados

Solo los orificios
izquierdos
(representados
en rojo) están
electrificados.

REF: 4786

Tubos
sin carril
eléctrico

1 Cremallera
electrificada
1 o 2 caras

1C REF: 4786
+4862

2C REF: 4787
+4863



3 Grapas para
colgar
paneles

2 posibles
modelos:



6 Paneles
(Propuesta
de material)



2 Cremallera
sin carril
eléctrico
1 o 2 caras

1C REF: 4786
2C REF: 4787

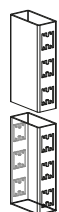

4 Tirantes



5 Pies
autoportantes



7 Accesorios

Personalizable:
- Estantes
- Barras
- Letreros



MONTAJE CON EL SISTEMA -> MAGNETIC

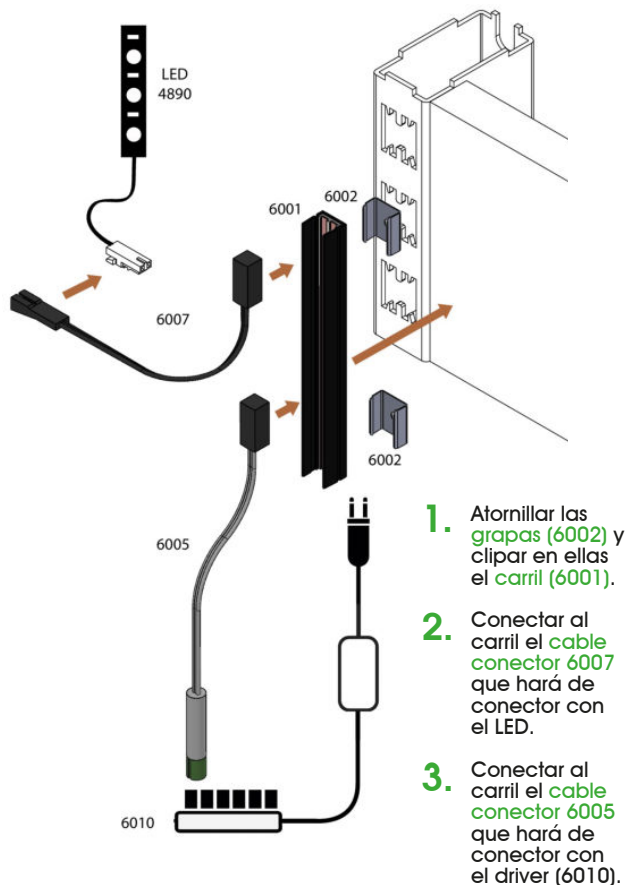

* Los cables conectores se fijan con imán automáticamente al acercar las boquillas imantadas al carril (6001).

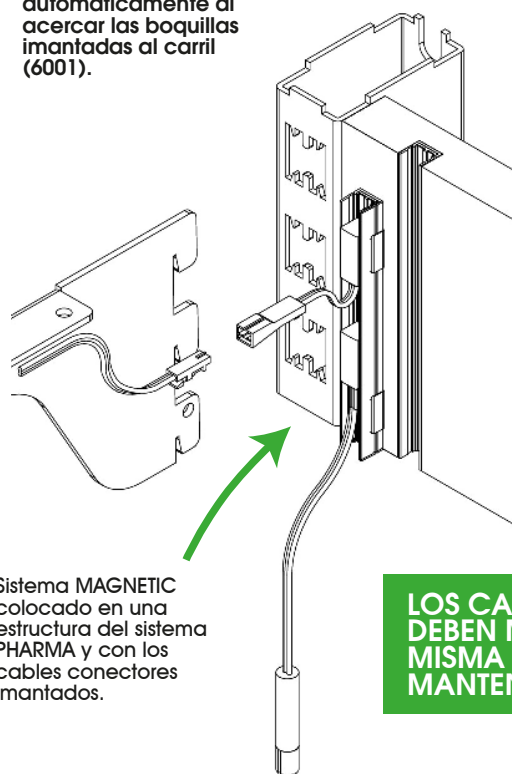

MONTAJE CON EL SISTEMA -> EASY

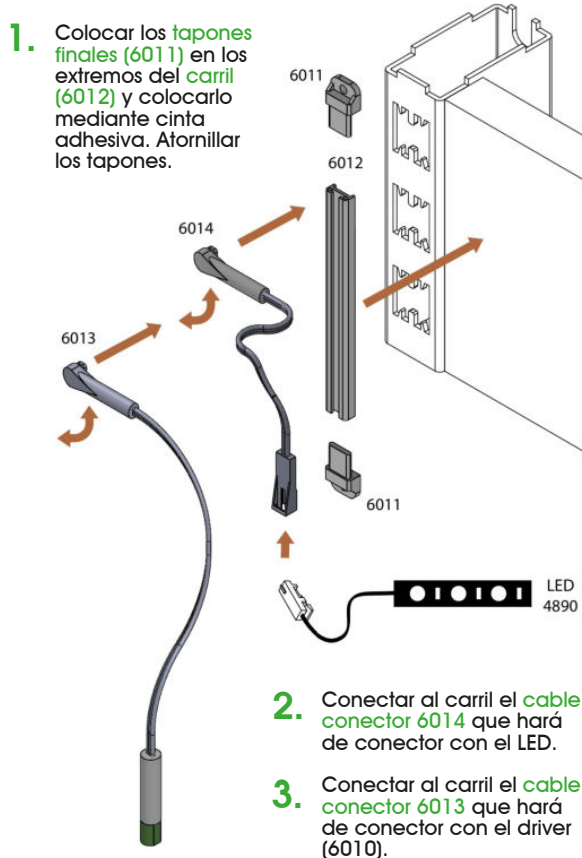

* Los cables conectores entran con la boquilla en perpendicular y al realizar un cuarto de giro (quedando alineados con el carril) quedan totalmente fijados.

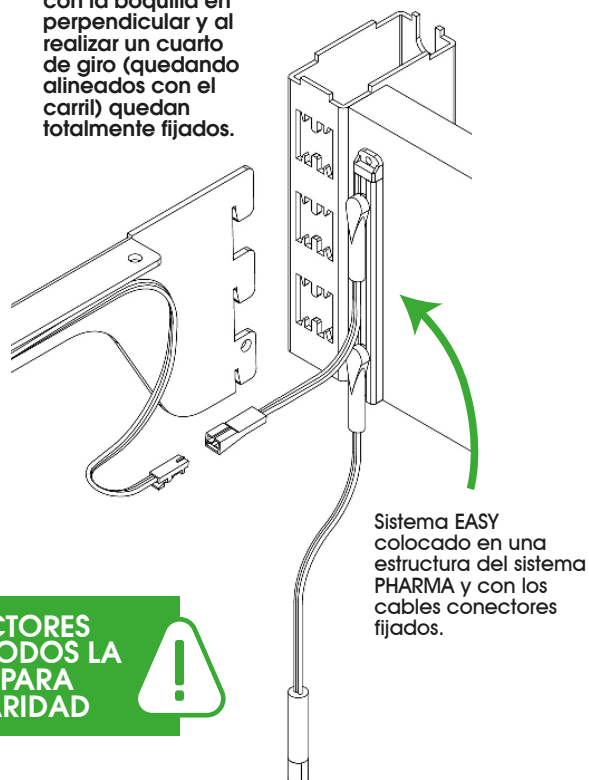

LOS CABLES CONECTORES DEBEN MANTENER TODOS LA MISMA DIRECCIÓN PARA MANTENER LA POLARIDAD





MONTAJE DE LOS PLAFONES A LAS CREMALLERAS

CARACTERÍSTICAS DEL SISTEMA

- Compatible con la mayoría de accesorios del sistema Kadí
- Módulos de 512, 730 y 820 mm entre ejes de columna
- Posibilidad de regular altura de estantes independientemente.
- Sistema modular que permite la combinación de 3 soluciones:

SYSTEM FEATURES

- Compatible with most Kadí system accessories
- Modules 512, 730 and 820 mm column between axes
- Possibility to adapt height of independent shelves
- Modular system that allows the combination of 3 solutions:

CARATTERISTICHE DEL SISTEMA

- Compatibile con la maggior parte degli accessori del sistema Kadí
- Moduli di 512, 730 e 820 mm fra assi dei montanti
- Possibilità di altezze regolari di mensole indipendenti
- sistema modulare che permette la combinazione di 3 soluzioni:

CARACTÉRISTIQUES DU SYSTÈME

- Compatible avec la plupart des accessoires Kadí
- Modules de 512, 730 et 820 mm empâtement colonne
- Possibilité de hauteur régulière des étagères indépendantes
- Système modulaire qui permet la combinaison de 3 solutions:

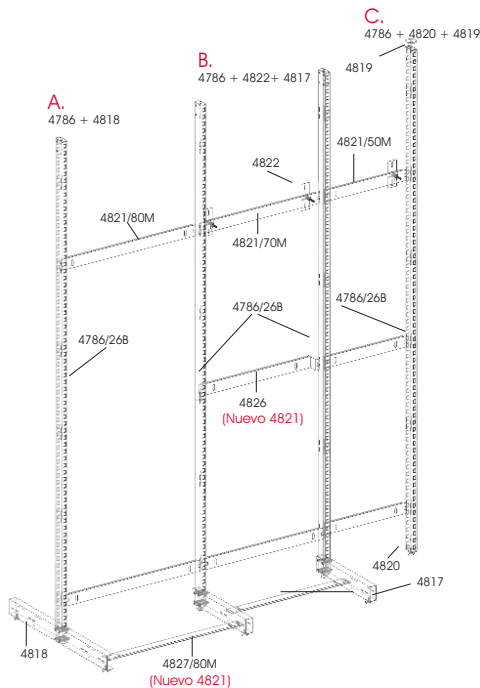

Solución GÓNDOLA

Solution GONDOLA
Solution GONDOLA
soluzione GONDOLA

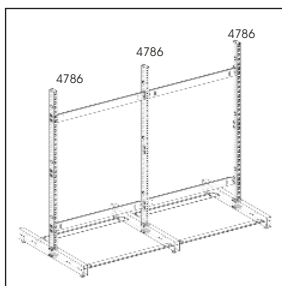

Solución GÓNDOLA ó PARED DIVISORIA

Solution GONDOLA ou PARI SEPARATRICE
Solution GONDOLA or PARTITION WALL
soluzione GONDOLA o parete divisoria

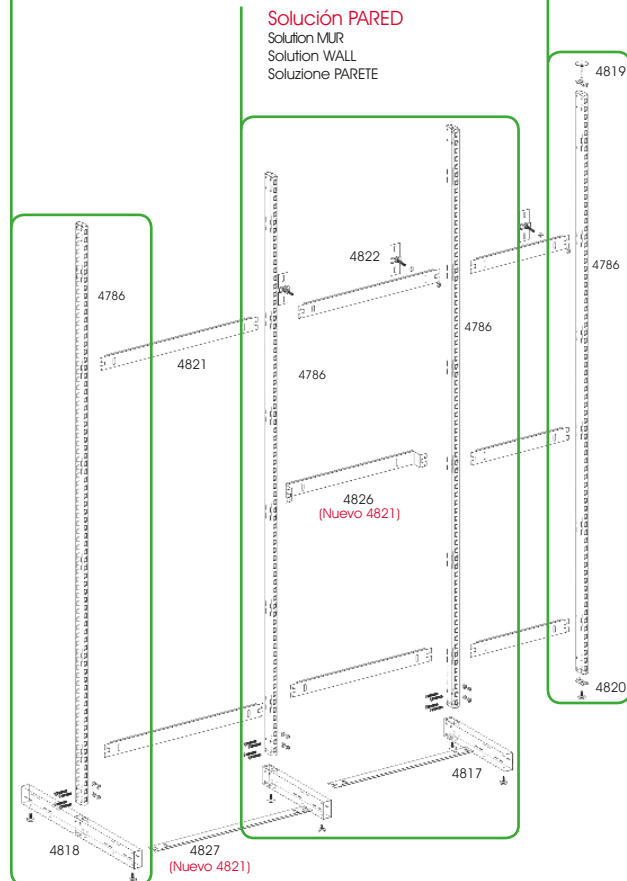

Solución PARED

Solution MUR
Solution WALL
Soluzione PARETE

4821 TIRANTES EN PLANO DIFERENTES

El uso de tirantes de unión en planos diferentes confiere más estabilidad a la góndola.

La utilisation de tirants dans de planes différents donne plus de stabilité à la góndola.

The use of rods spacer in different planes gives more stability to the gondola.

L'impiego di tiranti su piani differenti conferisce maggiore stabilità alla gondola.

4827 TIRANTE PARA PIES

NUEVOS TIRANTES 4821
(APTOS PARA PIES Y MONTANTES)

El uso de tirantes de unión en planos diferentes confiere más estabilidad a la góndola.

La utilisation de tirants dans la base donne plus de stabilité à la gondola.

The use of rods spacer in the base gives more stability to the gondola.

L'impiego di tiranti nella base conferisce maggiore stabilità alla gondola.

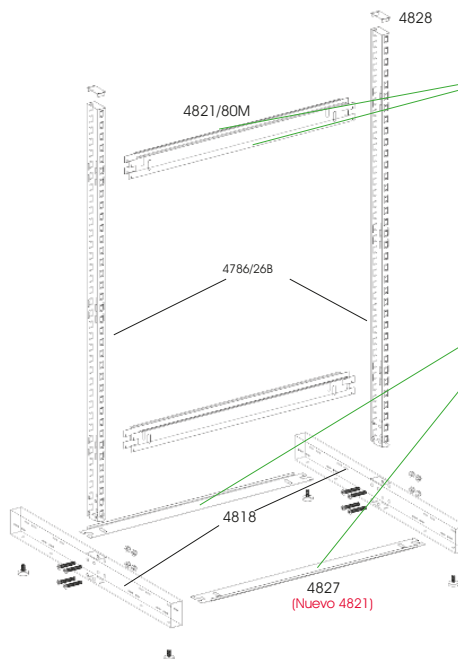

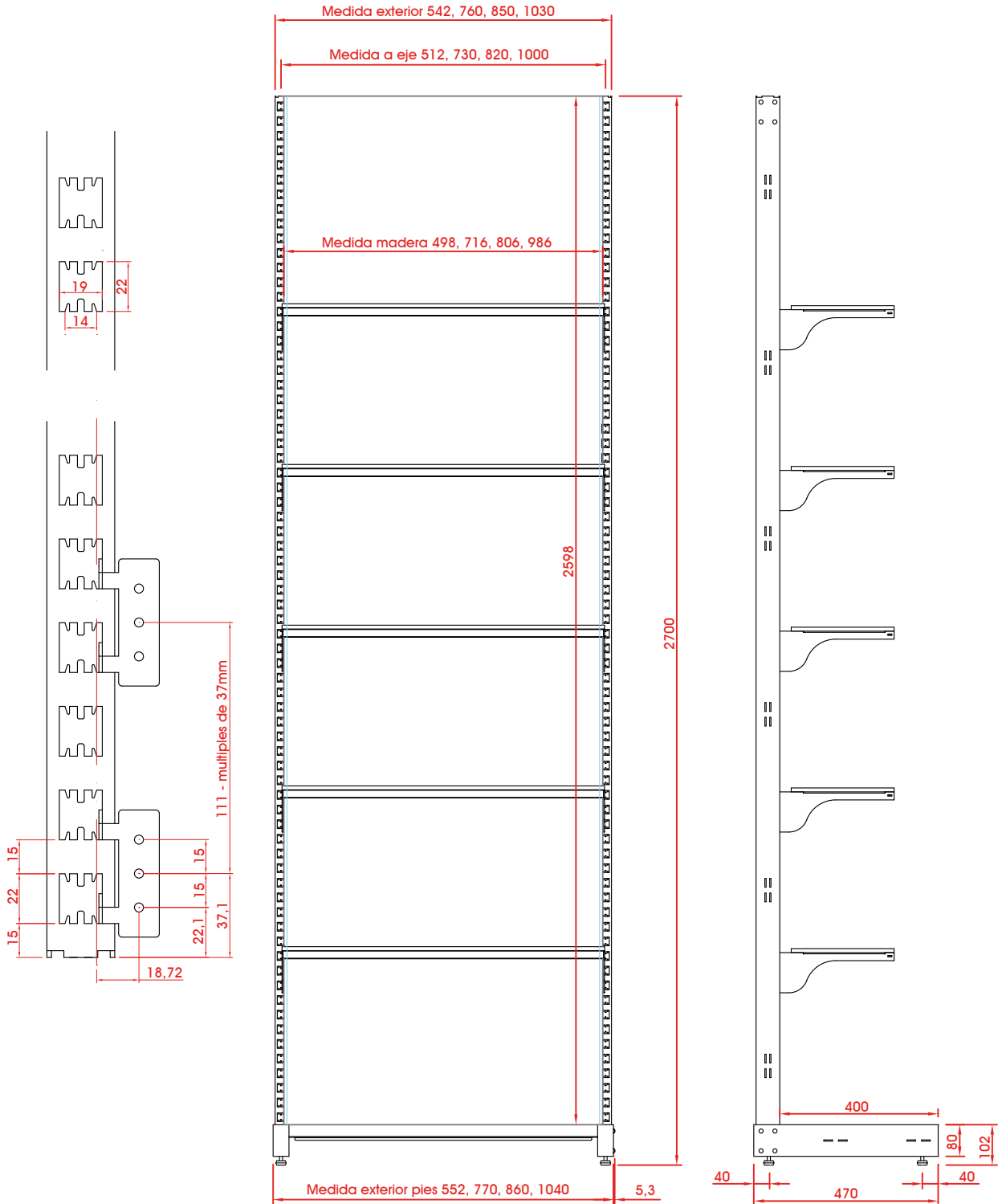



TOPE, GRAPAS Y CABLE

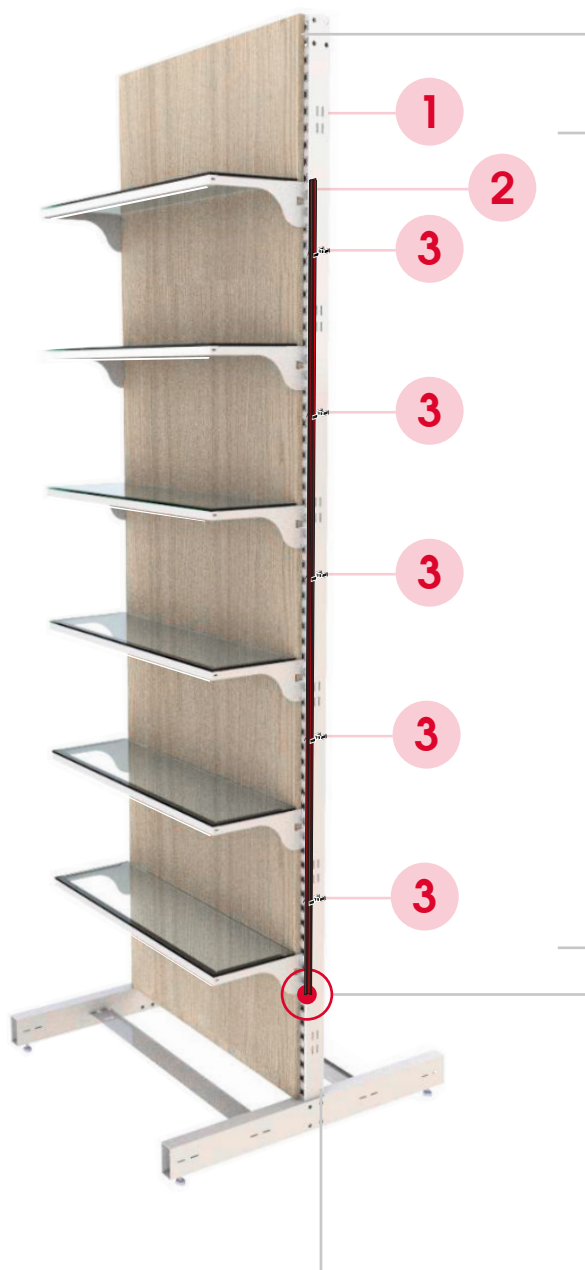

Para paneles de máx. 16mm

Pour les panneaux max. 16mm
For max panels 16mm
Per pannelli massimi 16mm

3 Grapas de plástico



- Las grapas deben ir repartidas de manera equitativa
- Colocar entre 4 y 8 grapas dependiendo de la medida.
- Tanto el tubo Pharma (1) como el carril electrificado (2) se pueden adaptar a cualquier medida. Posibilidad de cortar.

INICIO DEL CARRIL ELECTRIFICADO

4 Tope inferior

El tope inferior puede colocarse en cualquier orificio de la cremallera

Crema el inicio del carril electrificado

El carril queda apoyado al tope

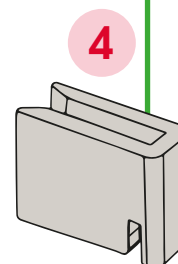
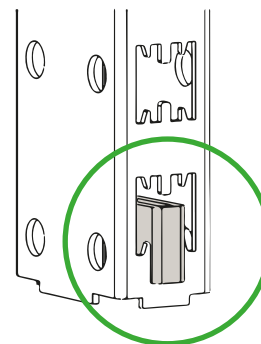

Orificio de salida del cable eléctrico por la parte trasera inferior del tubo.

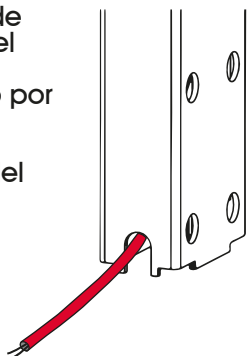



CARRIL
ELECTRICO

1 Tubo
Pharma
60x30

2 Carril
eléctrico

3 Grapas
de plástico

4 Tope
inferior

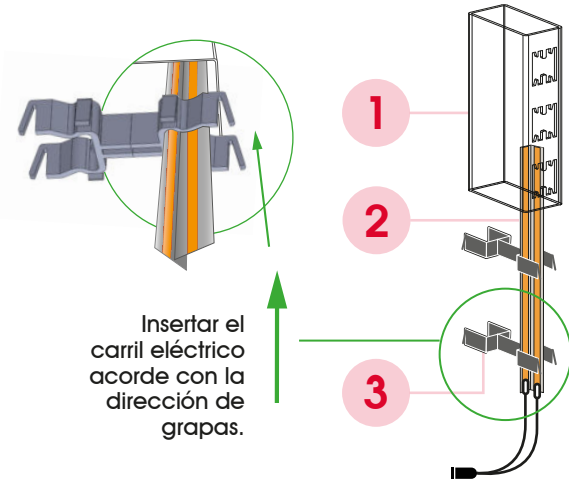

CREMALLERA ELECTRIFICADA
1 CARA

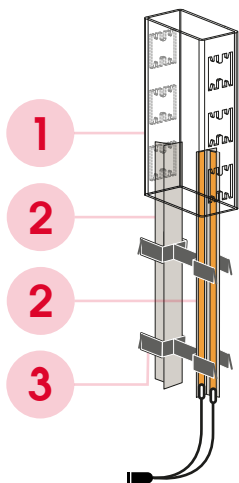
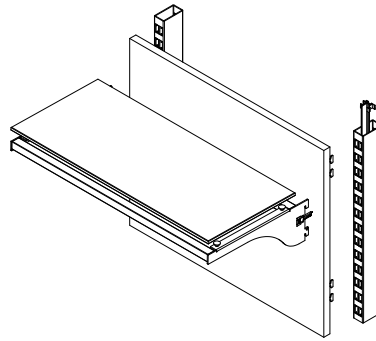

CREMALLERA ELECTRIFICADA
2 CARAS

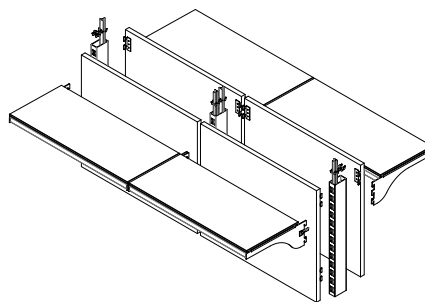

COLOCACIÓN DEL CONECTOR

5 Conector

6 Grapas
de fijación
para el conector

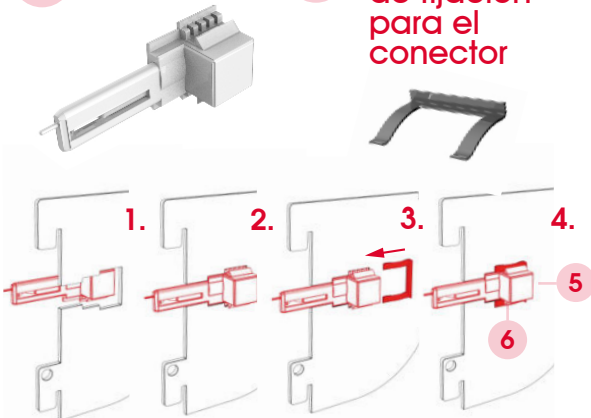

CARRIL-CABLE

- El carril electrificado lleva soldado el cable de conexión en la parte inferior. En el caso de precindir de este conector, prestar atención a la polaridad de los cables para el correcto funcionamiento de la nueva conexión.

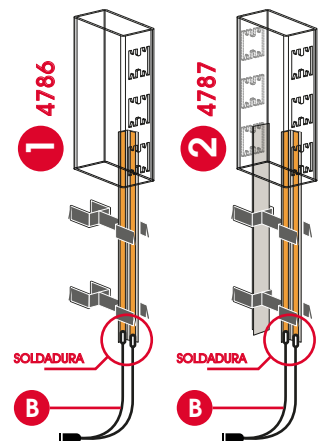



ACCESORIOS PHARMA

Vidrio
 Madera
 Diferentes materiales y acabados

ESTANTES

CARGA LIGERA



6890..



NUEVO

6891..



NUEVO

CARGA MEDIA



5894..



NUEVO

5896..



NUEVO

CARGA ALTA



5895..



NUEVO

BARRAS

CARGA LIGERA



5898..



NUEVO

5901..



NUEVO

CARGA MEDIA



5897..



NUEVO

PORTA ROTULOS

CARGA LIGERA



5391



NUEVO



TABLA DE PESOS

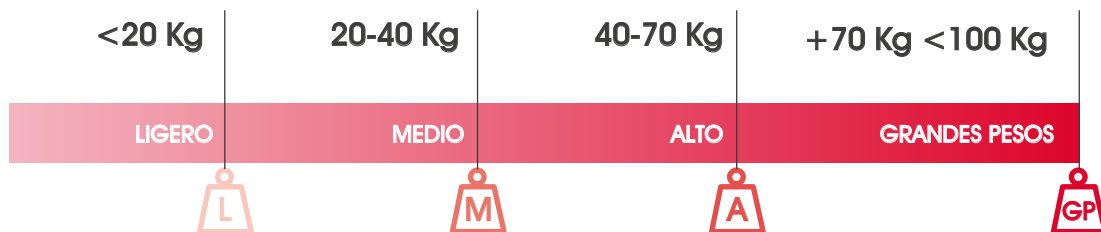

COMPORTAMIENTO DE CARGA



Puntos conflictivos de carga



La inclinación puede variar dependiendo del peso y la flexibilidad del aluminio.

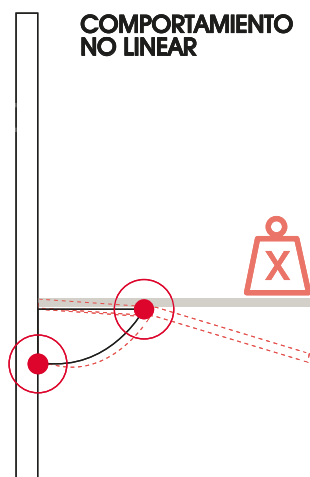
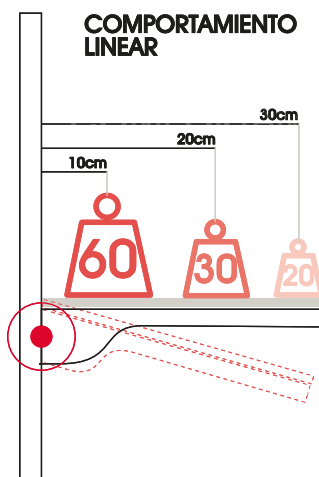

PLUG & PLAY

AL
ENCAJAR
SE ENCIENDE



Con el sistema PLUG & PLAY el montaje de los módulos de carga resulta fácil, rápido y muy práctico, ya que solo encajando las cartelas a las cremalleras, el circuito eléctrico queda totalmente conectado y el LED encendido.

- FÁCIL
- RÁPIDO
- PRÁCTICO





COMPONENTES POR PIEZA/METRO

CREMALLERAS

1 CARA

2 CARAS

COLUMNA TROQUELADA.
1 CARA
COLONNE PERFORATION SIMPLE
1 CÔTÉ
UPRIGHT SINGLE SLOT CHANNEL
1 SIDE
TUBO PERFORAZIONE SEMPLICE
1 LATO

4786/26B 2678MM

PLANTA

COLUMNA TROQUELADA.
2 CARAS
COLONNE PERFORATION SIMPLE
2 CÔTÉS
UPRIGHT SINGLE SLOT CHANNEL
2 SIDES
PIANTANA PERFORAZIONE
SINGOLA 2 LATI

4787/26B 2678MM
4787/13B 1337MM

PLANTA

ZINCADO BLANCO
PL. ZINK BLANC
ZINK PL. WHITE
ZINCATO BIANCO

34 0B

Fe 60x30x2mm €/u

GRAPAS



ANCLAJES PANELES MADERA
CROCHET PANNEAUX EN BOIS
HOOK WOOD PANELS
GANCIO PER PANNELLI IN LEGNO

4823/034

ANCLAJES METACRILATO Y VIDRIO
SUPPORT MÉTHACRYLATE ET VERRE
METHACRYLATE AND GLASS SUPPORT
SUPPORTOPPER PLEXIGLAS E VETRO

4824/034

Fe 4814 - 4815 €/u

Fe 6-8mm €/u

MAGNETIC LED

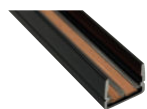

MAGNÉTICO

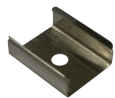

MAGNÉTICO



MAGNÉTICO



MAGNÉTICO

**CARRIL ELECTRIFICADO
MAGNÉTICO**
RAIL ÉLECTRIFIÉ MAGNÉTIQUE
MAGNETIC ELECTRIFIED RAIL
BINARIO ELETRIFICATO
MAGNETICO

6001/20N

CLIP PARA FIJACIÓN
CLIP DE FIXATION
FIXING CLIP
CLIP DI FISSAGGIO

6002/028

**CONECTOR MAGNÉTICO
CARRIL-DRIVER**
CONNECTEUR MAGNÉTIQUE
RAIL-DRIVER
MAGNETIC CONNECTOR
RAIL-DRIVER
CONNETTORE MAGNETICO
RAIL-DRIVER

6005/00N

**CONECTOR MAGNÉTICO
CARRIL-CONECTOR CARTELAS KADÍ**
CONNECTEUR MAGNÉTIQUE
RAIL-CONNECTEUR SUPPORT KADI
MAGNETIC CONNECTOR
RAIL-CONNECTOR KADI BRACKET
CONNETTORE MAGNETICO BINARIO
- CONNETTORE MENSOLA KADI

6006/00N

**CONECTOR MAGNÉTICO
CARRIL-LED UNIVERSAL**
CONNECTEUR MAGNÉTIQUE
RAIL-LED UNIVERSAL
MAGNETIC CONNECTOR
RAIL-UNIVERSAL LED
CONNETTORE MAGNETICO
BINARIO-UNIVERSALE LED

6007/00N

INOX SAT NEGRO
INOX SAT NOIR
S.S.S. BLACK
INOX SAT NERO

28 0N

2m €/u

6001-6012 €/u

Pla 2A €/u
150cm

Pla 2A €/u
40cm

Pla 2A €/u
40cm

DRIVER



6 SALIDAS

**DRIVER 100W, 24V /
CONECTOR HEMBRA**
CONDUCTEUR 100W, 24V /
CONNECTEUR FEMELLE
DRIVER 100W, 24V / FEMALE CONNECTOR
DRIVER 100W, 24V / CONNETTORE FEMMINA

6010/009

**CABLE CON MINI-CONECTORES
230V**
CABLE + MINI PLUG - 230V
CABLE + MINI PLUG - 230V
CAVO + MINI PLUG - 230V

6015/00B

CONECTOR DRIVER 6 VÍAS 20CM
CONNECTEUR PLONGEUR 6
VOIES 20CM
6-WAY DRIVER CONNECTOR
20CM
CONNETTORE SUBACQUEO A 6
VIE 20 CM

6021/009

CABLE ALARGO MACHO-HEMBRA 3M
CÂBLE D'EXTENSION MÂLE-FEMELLE DE
3 M
3M MALE-FEMALE EXTENSION CABLE
CAVO DI PROLUNGA
MASCIO-FEMMINA 3M

6022/00B

PLÁSTICO
PLASTIQUE
PLASTIC
PLASTICA

09

Pla 24V 100W €/u
15cm

Pla 3m €/u
230V 2,5A

Pla 3m €/u
230V 2,5A

CABLES



CABLE MINI PLUG - ABIERTO 24V
CABLE MINI PLUG - OVERTE 24V
CABLE MINI PLUG - OPEN ENDED 24V
CAVO MINI PLUG - APERTO 24V

4888/009

Pla 400m €/u
24V 2,5A

EASY



**CARRIL ELECTRIFICADO
RAIL ÉLECTRIFIÉ**
ELECTRIFIED RAIL
BINARIO ELETRIFICATO

6012/25.

CINTA MAGNÉTICA ADHESIVA
RUBAN MAGNÉTIQUE ADHÉSIF
ADHESIVE MAGNETIC TAPE
NASTRO MAGNETICO ADESIVO

6012/000 50M
6012/100 1M

CINTA ADHESIVA DOBLE CARA
RUBAN MAGNÉTIQUE ADHÉSIF
ADHESIVE MAGNETIC TAPE
NASTRO MAGNETICO ADESIVO

6012/009 66M

**CONECTOR CARRIL-DRIVER/
CONECTOR SEGURIDAD ALUSYSTEM**
CONNECTEUR RAIL-DRIVER /
CONNECTEUR SÉCURITÉ DU ALUSYSTEM
CONNECTOR RAIL-DRIVER /
CONNECTOR ALUSYSTEM SECURITY
CONNETTORE RAIL-DRIVER /
CONNETTORE LA SICUREZZA ALUSYSTEM

6013/0..

CONECTOR CARRIL-LED / HEMBRA
CONNECTEUR RAIL-LED / FEMELLE
RAIL-LED CONNECTOR / FEMALE
CONNETTORE RAIL-LED / FEMMINA

6014/0..

TAPÓN FINAL
BOUCHON D'EXTRÉMITÉ
END CAP
TAPPO TERMINALE

6011/0.. SET 2 U.

BLANCO NEGRO
BLANC NOIR
WHITE BLACK
BIANCO NERO

0B 0N

2,5m 24V €/u

PLÁSTICO
PLASTIQUE
PLASTIC
PLASTICA

09

€/u

€/m

Pla 24V €/u
1M

Pla 24V €/u
10cm

€/u



COMPONENTES POR PIEZA/METRO

KITS CARRIL ELECTRIFICADO

KIT
1CARA



KIT PERFIL DE ALUMINIO
ELECTRIFICADO A UNA CARA
CON GRAPAS DE PLÁSTICO
KIT PROFILÉ ALUMINIUM
ÉLECTRIFIÉ D'UN CÔTÉ AVEC DES
AGRAFES EN PLASTIQUE
KIT ALUMINIUM PROFILE
ELECTRIFIED ON ONE SIDE WITH
PLASTIC STAPLES
KIT PROFILO IN ALLUMINIO
ELETRIFICATO SU UN LATO CON
GRAFFE IN PLASTICA

4862/024 240 CM
4862/018 180 CM
4862/012 120 CM

Fe 55x26mm €/m

PL. M
ALU. M
ALL. NAT
01

Nº COMPONENTES/MEDIDA

MEDIDA	240 cm	180 cm	120 cm
Grapas	X8 uds	X6 uds	X4 uds
Carril electrificado	1 carril de 240	1 carril de 180	1 carril de 120
Tope inferior	X1 ud	X1 ud	X1 ud

KIT
2CARAS



KIT PERFIL DE ALUMINIO
ELECTRIFICADO CON GRAPAS
DE PLÁSTICO
KIT PROFILÉ ALUMINIUM
ÉLECTRIFIÉ DOUBLE FACE AVEC
CLIPS EN PLASTIQUE
KIT DOUBLE-SIDED ELECTRIFIED
ALUMINIUM PROFILE WITH
PLASTIC CLIPS
KIT PROFILO IN ALLUMINIO
ELETRIFICATO BIFACCIALE CON
CLIPS IN PLASTICA

4863/024 240 CM
4863/018 180 CM
4863/012 120 CM

Fe 55x26mm €/m

Nº COMPONENTES/MEDIDA

MEDIDA	240 cm	180 cm	120 cm
Grapas	X8 uds	X6 uds	X4 uds
Carril electrificado	2 carriles de 240	2 carriles de 180	2 carriles de 120
Tope inferior	X2 uds	X2 uds	X2 uds

SISTEMA DE FÁCIL CONEXIÓN - PLUG & PLAY

KITS CARRIL ELECTRIFICADO

KIT
1CARA

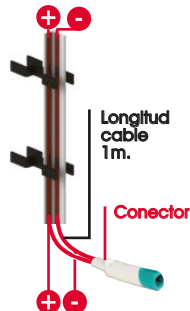

KIT PERFIL DE ALUMINIO
ELECTRIFICADO A UNA CARA
CON GRAPAS DE PLÁSTICO
KIT PROFILÉ ALUMINIUM
ÉLECTRIFIÉ D'UN CÔTÉ AVEC DES
AGRAFES EN PLASTIQUE
KIT ALUMINIUM PROFILE
ELECTRIFIED ON ONE SIDE WITH
PLASTIC STAPLES
KIT PROFILO IN ALLUMINIO
ELETRIFICATO SU UN LATO CON
GRAFFE IN PLASTICA

4862/X24 240 CM
4862/X18 180 CM
4862/X12 120 CM

Fe 55x26mm €/m

PL. M
ALU. M
ALL. NAT
01

Nº COMPONENTES/MEDIDA

MEDIDA	240 cm	180 cm	120 cm
Grapas	X8 uds	X6 uds	X4 uds
Carril electrificado	1 carril de 240	1 carril de 180	1 carril de 120
Tope inferior	X1 ud	X1 ud	X1 ud
Conector	X1 ud	X1 ud	X1 ud

KIT
2CARAS

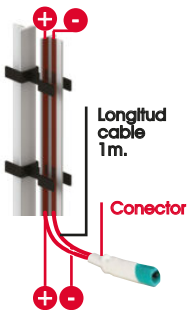

KIT PERFIL DE ALUMINIO
ELECTRIFICADO CON GRAPAS
DE PLÁSTICO
KIT PROFILÉ ALUMINIUM
ÉLECTRIFIÉ DOUBLE FACE AVEC
CLIPS EN PLASTIQUE
KIT DOUBLE-SIDED ELECTRIFIED
ALUMINIUM PROFILE WITH
PLASTIC CLIPS
KIT PROFILO IN ALLUMINIO
ELETRIFICATO BIFACCIALE CON
CLIPS IN PLASTICA

4863/X24 240 CM
4863/X18 180 CM
4863/X12 120 CM

Fe 55x26mm €/m

Nº COMPONENTES/MEDIDA

MEDIDA	240 cm	180 cm	120 cm
Grapas	X8 uds	X6 uds	X4 uds
Carril electrificado	2 carriles de 240	2 carriles de 180	2 carriles de 120
Tope inferior	X2 uds	X2 uds	X2 uds
Conector	X2 uds	X2 uds	X2 uds

CONECTORES

COMPATIBLE KADÍ PRIMO

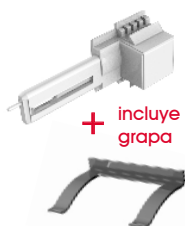

+ incluye grapa

CONECTOR PLUG & PLAY,
BLANCO / NEGRO
CONNECTEUR PLUG & PLAY,
BLANC / NOIR
CONNECTOR PLUG & PLAY,
WHITE / BLACK
CONNETTORE PLUG & PLAY,
BIANCO / NERO

84864/00B
84864/00N

PLÁSTICO
PLASTIQUE
PLASTIC
PLASTICA
09

Pla 1 m
CE IP20
24V max.3A €/u

Cualquier
manipulación invalida
la garantía del
fabricante





PIES Y ANCLAJES

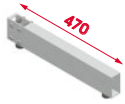

PIE AUTOPORTANTE A PARED
 PIED AUTOPORTANT MUR
 SELF-SUPPORTING FOOD
 BASE AUTOPORTANTE A PARETE
4817/00B

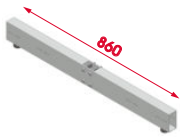

PIE AUTOPORTANTE GÓNDOLA
 PIED GONDOLA
 GONDOLA FOOD
 BASE GONDOLA
4818/00B



ANCLAJE TECHO-SUELO
 VÉRIN SUPÉRIEUR
 UPPER LEVEL
 LIVELLATORE SUPERIORE
4819/00B



BASE COLUMNA
 VÉRIN INFÉRIEUR
 LOWER LEVEL
 LIVELLATORE INFERIORE
4820/00B



KIT DE Z CON RUEDA DE ALTA RESISTENCIA
 KIT Z AVEC ROUE ROBUSTE
 Z KIT WITH HEAVY DUTY WHEEL
 Z KIT CON RUOTA PER SERVIZIO PESANTE
4818/R0B



FIJACIÓN TIRANTES A PARED
 PATTES DE FIXATION
 ROD-SPACER WALL SUPPORT
 FISSAGIO TIRANTI A PARED
4822/00B

BLANCO
 BLANC
 WHITE
 BIANCO
OB

Fe 80x40x2mm €/u

○

Fe 80x40x2mm €/u

○

Fe 60x30x3mm €/u

○

Fe 60x30x3mm €/u

○

Fe 80x40x2mm €/u

○

Fe 80x40x2mm €/u

○

TIRANRES

BLANCO
 BLANC
 WHITE
 BIANCO
OB

Fe €/u

○

○

○

○

○

○

○

○

○

○

○

○

○

○

○

○

○

○

○

○

○

○

○

○

○

○

○

○

○

○

○

○

○

○

○

○

○

○

○

○

○

○

○

○

○

○

○

○

○

○

○

○

○

○

○

○

○

○

○

○

○

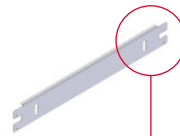

TIRANTES DISTANCIADORES
 TIRANT-ESPACEMENT
 ROD-SPACER
 TIRANTE-DISTANZIATORE
4821/50B EJE 512 MM
4821/60B EJE 670 MM
4821/70B EJE 730 MM
4821/80B EJE 820 MM
4821/10B EJE 1000 MM

P: PARED (DIST. ENTRE COLUMNAS)

S: SUELO (DIST. ENTRE PIES)

MISMO TIRANTE PARA MONTANTES Y PIES

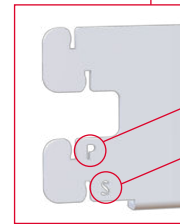

TIRANTE (ILUMINACIÓN)
 TIRANT-ESPACEMENT (ÉCLAIRAGE)
 ROD-SPACER (LIGHTING)
 TIRANTE (ILLUMINAZIONE)
***4826/70B** EJE 730 MM
***4826/80B** EJE 820 MM



TIRANTE ENTRE PIES
 TIRANT-ESPACEMENT ENTRE LE PIED
 ROD-SPACER BETWEEN FEET
 TIRANTE FRA BASI MONTANTI
***4827/50B** EJE 512 MM
***4827/70B** EJE 650 MM



TIRANTE TELESCÓPICO
 TIRANT TELESCOPIQUE
 TELESCOPIC ROD-SPACER
 TIRANTE TELESCOPICO
4840/00B

JUNTAS Y TAPAS

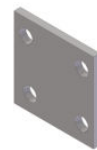

EMPALMADOR COLUMNA
 JOINT COLONNES
 COLUMNS JOINT
 GIUNZIONE PIANTANE
4825/00B

Fe 90X50 mm €/u

○

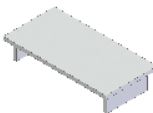

TAPA COLUMNA
 BOUCHON
 END-CAP UPRIGHT
 COPRITESTA PIANTANA
4828/00B

Fe 60X30 mm €/u

○



PORTA

RÓTULOS 5391/1..

* MADERA NO INCLUIDA

COMPATIBLE
KADÍ PRIMO



MATERIAL RÓTULO *
NO INCLUIDO

CARTELA CON CONECTOR
PARA LETREROS CON
ILUMINACIÓN
5391/0..

SIN MONTAJE

Placard avec
connecteur pour
enseignes lumineuses.
Placard with connector
for illuminated signs.
Cartello con connettore
per insegne luminose.

1M máx.
7 cm

Fe 72 mm medida útil

BLANCO BLANC WHITE BIANCO	NEGRO NOR BLACK NERO	COLOR COULEUR COLOR COLORE
OB	ON	OP

○	○	○	€/u
---	---	---	-----

ESTANTE

MADERA 5896/1..

COMPATIBLE
KADÍ PRIMO



MADERA *
NO INCLUIDA

ESTANTE DE MADERA
CON ILUMINACIÓN
FRONTAL EMPOTRADA
Y PERFIL DE ALUMINIO
5896/1..

SIN MONTAJE

Étagère en bois avec
éclairage zénithal monté sur
l'étagère
Wooden shelf with zenithal
lighting mounted on the shelf
Ripiano legno con
illuminazione zenitale
impotrata nel ripiano

1M máx.
28 cm

PL. M. ALU. M. ALU. M. ALL. NAT.	BLANCO BLANC WHITE BIANCO	NEGRO NOR BLACK NERO	COLOR COULEUR COLOR COLORE
O1	OB	ON	OP

○	○	○	€/u
---	---	---	-----

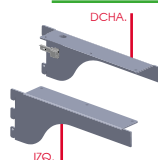

Kit 2 cartelas:
DERECHA (con
conector) +
IZQUIERDA

KIT CARTELAS ESTANTE MADERA
CON ILUMINACIÓN
KIT SUPPORTS BOIS ILLUMINATION
WOOD LIGHTING BRACKETS KIT
KIT MENSOLE LEGNO
ILLUMINAZIONE

5381/0..

Fe	4890	€/u
	282 mm medida útil	

○	○	○
---	---	---



Medidas
mecanizado
16 x 6.8 mm

KIT PERFIL ALUMINIO CON
DIFUSOR
KIT PROFIL EN ALUMINIUM AVEC
DIFFUSEUR
KIT PROFILO IN ALLUMINIO CON
DIFFUSORE

3971/1..

Al	2M	18x9mm	€/m
----	----	--------	-----

○



126 diodos (20λ);
cortable cada
5.5 cm
Cable, fil, wire,
cavo: 40cm
Ancho 8 mm
flexible y con
cinta adhesiva
fleible and
self-adhesive

LED CON MINI-CONECTOR 24V
BANDE LED AVEC MINI-PLUG 24V
LED STRIP WITH MINI-PLUG 24V
STRIACIA LED CON MINI-PLUG
24V

4890/009

Pla	1 m	5000 K	€/u
	>90	9,6 W 24V	

○

POSIBILIDAD DE COMBINAR CON
EL SISTEMA "CUT-LINE"

SISTEMA DE PERFIL DE ALUMINIO CON LED INCORPORADO
SE PUEDE ENCASTRAR A LA MADERA O AUTOADHESIVAR

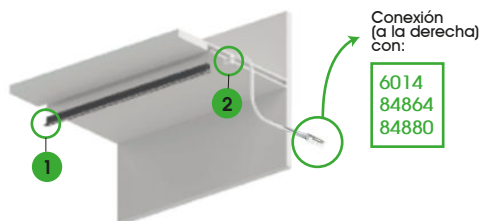

Conexión
(a la derecha)
con:
6014
84864
84880

CORTE TOTALMENTE LIBRE, SIN LIMITES DE MEDIDAS

SE CORTA TODA LA ESTRUCTURA Y EL LED A LA MEDIDA DESEADA
Y SE REMATA CON LOS TAPONES FINALES POR AMBOS LADOS

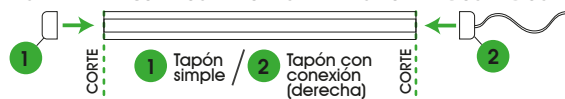

SISTEMA CUT-LINE

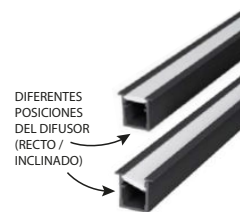

DIFERENTES
POSICIONES
DEL DIFUSOR
(RECTO /
INCLINADO)

PERFIL DE ALUMINIO CON LED
INCORPORADO
PROFILÉ EN ALUMINIUM AVEC LED
INTÉGRÉE
ALUMINIUM PROFILE WITH BUILT-IN LED
PROFILO IN ALLUMINIO CON LED
INTEGRATO

6025/301 4000K
6026/301 5000K

SET CONECTOR + TAPA
CABLE 40CM
6030/041

GRAPAS
6031/041

PL. M. ALU. M. ALU. M. ALL. NAT.
O1

Pla	3 m	€/u
	>90	9,6W 24V

○
○
○
○



ESTANTE

VIDRIO 5895/1..

* Recomendamos usar vidrios segurizados o laminados. (NO INCLUIDO)



VIDRIO * NO INCLUIDO

ESTANTE DE VIDRIO CON ILUMINACIÓN FRONTAL
5895/1..
MONTADO

Étagère en verre avec éclairage avant
Glass shelf with front lighting
Ripiano vetro con illuminazione frontale

1M máx. 29 cm

PARA MADERA O VIDRIO

€/u

PL. M	BLANCO	NEGRO	COLOR
ALU. M	BLANC	NOR	COULEUR
ALU. M	WHITE	BLACK	COLOR
ALL. NAT	BIANCO	NERO	COLORE
01	0B	0N	0P

ESTANTE

VIDRIO 5894/1..



VIDRIO * NO INCLUIDO

ESTANTE DE VIDRIO CON ILUMINACIÓN CENITAL FRONTAL
5894/1..
MONTADO

Étagère en verre avec éclairage zenithal frontal
Glass shelf with frontal zenithal lighting
Ripiano di vetro con illuminazione zenitale frontale

1M máx. 27 cm

PARA MADERA O VIDRIO

€/u

PLÁSTICO	BLANCO	NEGRO	COLOR
PLASTIQUE	BLANC	NOR	COULEUR
PLASTIC	WHITE	BLACK	COLOR
PLASTICA	BIANCO	NERO	COLORE
09	0B	0N	0P

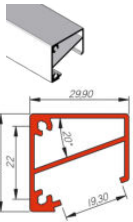

PERFIL ALUMINIO
PROFIL EN ALUMINIUM
ALUMINIUM PROFILE
PROFILO DI ALUMINIO
4744/1..

Al	5 m	30x30	€/m
Ⓞ 84602			

o o o o

Pla	2 m	Ⓞ 4744	€/m
-----	-----	--------	-----

o



DIFUSOR PLASTICO MATE
DIFFUSEUR EN PLASTIQUE MAT
MATT PLASTIC DIFFUSOR
DIFUSORE PLASTICO OPACO
84602/109

PLÁSTICO	09
PLASTIQUE	
PLASTIC	
PLASTICA	

o

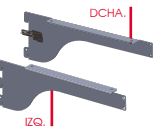

KIT CARTELAS ESTANTE VIDRIO CON ILUMINACIÓN
KIT SUPPORTS VERRE
ILUMINATION
GLASS LIGHTING BRACKETS KIT
KIT MENSOLE VETRO
ILLUMINAZIONE
3862/0..

Fe	Ⓞ 4744-2556-4890	€/u
292 mm medida útil		

o o o

Cada cartela tiene 2 taladros para usar 1 perfil 4744

Kit 2 cartelas: DERECHA (con conexión) + IZQUIERDA

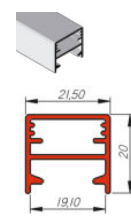

PERFIL ALUMINIO
PROFIL EN ALUMINIUM
ALUMINIUM PROFILE
PROFILO DI ALUMINIO
4748/1..

Al	6 m	21,5x20	€/m
Ⓞ 4893			

o o o

Pla	Ⓞ 4892 - 4894	€/m
-----	---------------	-----

PLÁSTICO	09
PLASTIQUE	
PLASTIC	
PLASTICA	

o



DIFUSOR PLASTICO MATE
DIFFUSEUR EN PLASTIQUE MAT
MATT PLASTIC DIFFUSOR
DIFUSORE PLASTICO OPACO
4893/109

Pla	2 m	Ⓞ 4892 - 4894	€/m
-----	-----	---------------	-----

o

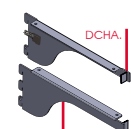

KIT CARTELAS ESTANTE VIDRIO CON ILUMINACIÓN
KIT SUPPORTS VERRE
ILUMINATION
GLASS LIGHTING BRACKETS KIT
KIT MENSOLE VETRO
ILLUMINAZIONE
5385/0..

Fe	Ⓞ 4744-2556-4890	€/u
270 mm medida útil		

o o o

Kit 2 cartelas: DERECHA (con conexión) + IZQUIERDA



LED CON MINI-CONECTOR 24V
BANDE LED AVEC MINI-PLUG 24V
LED STRIP WITH MINI-PLUG 24V
STRACIA LED CON MINI-PLUG 24V
4890/109

Pla	1 m	5000 K	€/u
Ⓞ CRI>90 Ⓞ 9,6 W 24V			

o

126 diodos (20λ); cortable cada 5,5 cm
Cable, fil, wire, cavo: 26cm
Ancho 8mm

flexible y con cinta adhesiva
fleible and self-adhesive

126 diodos (20λ); cortable cada 5,5 cm
Cable, fil, wire, cavo: 26cm
Ancho 8mm

flexible y con cinta adhesiva
fleible and self-adhesive



VENTOSA TRANSPARENTE
VENTOUSE
SUCITON
VENTOSA
2556/009

Pla	∅14 mm	Ⓞ 4880	€/u
-----	--------	--------	-----

o



VENTOSA TRANSPARENTE
VENTOUSE
SUCITON
VENTOSA
2556/009

Pla	∅14 mm	Ⓞ 4880	€/u
-----	--------	--------	-----

o



*** ESTANTE**

VIDRIO 5890/1..

* Recomendamos usar vidrios segurizados o laminados. (NO INCLUIDO)



VIDRIO *
NO INCLUIDO

ESTANTE DE VIDRIO
RETROILUMINADO

*5890/1..

MONTADO

Étagère en verre extra claire retro-éclairé
Blacklit optical glass shelf
Ripiano vetro extralight retroilluminato

1M máx.
30 cm

PL. M	BLANCO	NEGRO	COLOR
ALU. M	BLANC	NOIR	COULEUR
ALL. NAT	WHITE	BLACK	COLOR
	BANCO	NERO	COLORE
01	0B	0N	0P

*o *o *o

€/u

*** ESTANTE**

VIDRIO 5891/1..



VIDRIO *
NO INCLUIDO

ESTANTE DE VIDRIO
CON ILUMINACIÓN
FRONTAL

*5891/1..

MONTADO

Étagère en verre avec éclairage zénithal frontal
Glass shelf with frontal zenithal lighting
Ripiano di vetro con illuminazione zenitale frontale

1M máx.
30 cm

PL. M	BLANCO	NEGRO	COLOR
ALU. M	BLANC	NOIR	COULEUR
ALL. NAT	WHITE	BLACK	COLOR
	BANCO	NERO	COLORE
01	0B	0N	0P

*o *o *o

€/u



Junta goma incluida
Joint en caoutchouc inclus
Inclus rubber gasket
Includet gasket di gomma inclusa

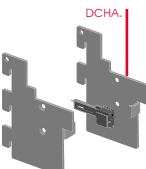

Con perfil 362
Kit 2 cartelas:
DERECHA (con
conector) +
IZQUIERDA



126 diodos (20λ);
cortable cada
5,5 cm
Cable, fil, wire,
cavo: 26cm
Ancho 8mm

flexible y con
cinta adhesiva
flexible and
self-adhesive

PERFIL ALUMINIO
PROFIL LAME D'ALUMINIUM
ALUMINIUM SLATWALL
PROFILE
PROFILO DOGATO
ALLUMINIO

*362/1..

Al	5 m	6-8mm	€/m
⊙	361/109		

*o *o *o *o

KIT CARTELAS ESTANTE
VIDRIO CON
ILUMINACIÓN
KIT SUPPORTS VERRE
ILUMINATION
GLASS LIGHTING
BRACKETS KIT
KIT MENSOLE VETRO
ILLUMINAZIONE

*5384/0..

Fe	362 - 4890	€/u
⊙	68,5mm medida útil	

*o *o *o

LED CON
MINI-CONECTOR 24V
BANDE LED AVEC
MINI-PLUG 24V
LED STRIP WITH
MINI-PLUG 24V
STRIACIA LED CON
MINI-PLUG 24V

4890/109

Pla	1 m	5000 K	€/u
⊙	CRI>90	9.6 W 24V	

o

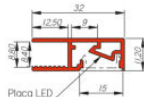

PERFIL ALUMINIO
PROFIL EN ALUMINIUM
ALUMINIUM PROFILE
PROFILO DI ALLUMINIO

4892/1..

DIFUSOR DE PLÁSTICO MATE
DIFFUSEUR EN PLASTIQUE MAT
MATT PLASTIC DIFUSOR
DIFUSORE PLASTICO OPACO

4893/109

KIT TAPAS FINALES LATERALES
COUVERTURE LATÉRALE FINALE
LATERAL END CAP
COPERTURA LATERALE FINALE

4894/0..

Al	5 m	32x11,2	€/m
⊙	4893 - 4894		

o o o o

Pla	4892 - 4894	€/m
⊙	2 m	

o

Pla	32x11,2 mm	€/u
⊙	4892	

o o

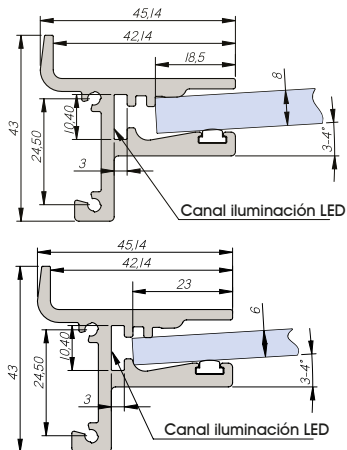

**(ES) • MÁXIMA
MEDIDA ESTANTE
RECOMENDADA:
100 X 30 CM.**

**(FR) • Maximum
recommended
shelf size: 100 x
30 cm.**

**(IT) • Dimensione
massima
raccomandata
dello scaffale:
100 x 30 cm.**

**(EN) • Taille
maximale de
l'étagère
recommandée:
100 x 30 cm.**



PENDERIE 5897/1..

* MADERA NO INCLUIDA

KIT compuesto por:
- Cartelas Ref.5382
-Tubo rectangular Ref.4900/12B
-LED de 1m



VIDRIO / MADERA NO INCLUIDO

ESTANTE + BARRA DE CUELQUE LATERAL CON ILUMINACIÓN Y PROTECCIÓN PLÁSTICA SUPERIOR 5897/1..

MONTADO

Tablette + barre de suspension latérale avec éclairage
Shelf + side hanging bar with lighting
Mensola + barra appendiabiti laterale con illuminazione

1M máx. 29cm

PLÁSTICO PLASTIQUE PLASTICA	BLANCO BLANC WHITE	NEGRO NOIR BLACK	COLOR COULEUR COLOR COLORE
09	0B	0N	0P

€/u

PARA MADERA O VIDRIO

BARRA DE CUELQUE LATERAL 5898/1..

KIT compuesto por:
- Cartelas Ref.5383
-Tubo rectangular Ref.4900/12B
-LED de 1m



BARRA DE CUELQUE LATERAL CON ILUMINACIÓN Y PROTECCIÓN PLÁSTICA SUPERIOR 5898/1..

MONTADO

Barre de suspension latérale avec éclairage
Side hanger bar with lighting
Barra appendiabiti laterale con illuminazione

1M máx. 29cm

PL. M ALL. M ALL. M ALL. NAT	BLANCO WHITE BIANCO	NEGRO BLACK NERO	COLOR COULEUR COLOR COLORE
01	0B	0N	0P

€/u

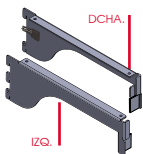

Kit 2 cartelas: DERECHA (con conector) + IZQUIERDA

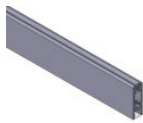

LED no incluido. LED recomendado de 5mm de ancho. Incluye perfil de plástico superior y difusor interior.

KIT CARTELAS BARRA ACCESORIOS
KIT SUPPORT BARRE ACCESSOIRES
KIT BRACKET FOR ACCESSORIES ROD
KIT MENSOLA TUBO PORTA-ACCESSORI 5382/00.

TUBO RECTANGULAR PARA ILUMINACIÓN 30X10MM CON PLETINA DE REFUERZO
KIT TUBE RECTANGULAIRE POUR ECLAIRAGE 30X10MM AVEC PLAQUE DE RENFORT
KIT RECTANGULAR TUBE FOR LIGHTING 30X10MM WITH REINFORCING PLATE
KIT TUBO RETTANGOLARE PER ILLUMINAZIONE 30X10MM CON PIASTRA DI RINFORZO 4900/12.

CON ALMA DE ACERO INOX

CARGA LIGERA max. 30KG

Fe	4900	€/u
	290 mm medida útil	

Al	1 m	30x10	€/u
	4901		

Pla	1 m	5000 K	€/u
	CRI>90	15,3W 24V	

PLÁSTICO PLASTIQUE PLASTICA

09

Pla	14 mm	4880	€/u
-----	-------	------	-----

LED CON MINI-CONECTOR 24V
BANDE LED AVEC MINI-PLUG 24V
LED STRIP WITH MINI-PLUG 24V
STRACIA LED CON MINI-PLUG 24V 4910/109

VENTOSA TRANSPARENTE VENTOUSE SUCITON VENTOSA 2556/009

182 diodos (20λ); cortable cada 3.8 cm
Cable, fil, wire, cavo: 40cm
Ancho 5mm
flexible y con cinta adhesiva flexible and self-adhesive

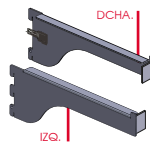

Kit 2 cartelas: DERECHA (con conector) + IZQUIERDA



LED no incluido. LED recomendado de 5mm de ancho. Incluye perfil de plástico superior y difusor interior.

KIT CARTELAS BARRA ACCESORIOS
KIT SUPPORT BARRE ACCESSOIRES
KIT BRACKET FOR ACCESSORIES ROD
KIT MENSOLA TUBO PORTA-ACCESSORI 5383/00.

TUBO RECTANGULAR PARA ILUMINACIÓN 30X10MM CON PLETINA DE REFUERZO
KIT TUBE RECTANGULAIRE POUR ECLAIRAGE 30X10MM AVEC PLAQUE DE RENFORT
KIT RECTANGULAR TUBE FOR LIGHTING 30X10MM WITH REINFORCING PLATE
KIT TUBO RETTANGOLARE PER ILLUMINAZIONE 30X10MM CON PIASTRA DI RINFORZO 4900/12.

CON ALMA DE ACERO INOX

CARGA LIGERA max. 30KG

Fe	4900	€/u
	290 mm medida útil	

Al	1 m	30x10	€/u
	4901		

Pla	1 m	5000 K	€/u
	CRI>90	15,3W 24V	

PLÁSTICO PLASTIQUE PLASTICA

09

SISTEMA CUT-LINE

DIFFERENTES POSICIONES DEL DIFUSOR (RECTO / INCLINADO)



PERFIL DE ALUMINIO CON LED INCORPORADO
PROFILÉ EN ALUMINIUM AVEC LED INTÉGRÉE
ALUMINIUM PROFILE WITH BUILT-IN LED
PROFILO IN ALLUMINIO CON LED INTEGRATO

6025/301 4000K
6026/301 5000K

SET CONECTOR + TAPA CABLE 40CM 6030/041

GRAPAS 6031/041

PL. M ALL. M ALL. M ALL. NAT 01

Pla	3 m	€/u
	CRI>90	9,6W 24V

0
0
0
0

SISTEMA DE PERFIL DE ALUMINIO CON LED INCORPORADO SE PUEDE ENCASTRAR A LA MADERA O AUTOADHESIVAR

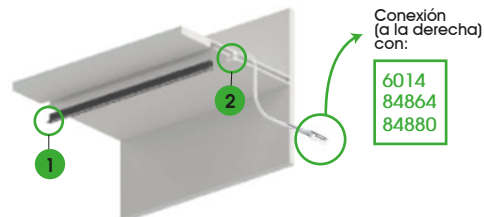

Conexión (a la derecha) con:

6014
84864
84880

CORTE TOTALMENTE LIBRE, SIN LIMITES DE MEDIDAS

SE CORTA TODA LA ESTRUCTURA Y EL LED A LA MEDIDA DESEADA Y SE REMATA CON LOS TAPONES FINALES POR AMBOS LADOS





BARRA ACCES. FR.

5901/1..

PL. M ALU. M ALU. M ALL. NAT	BLANCO BLANC WHITE BIANCO	NEGRO NOIR BLACK NERO	COLOR COULEUR COLOR COLORE
01	0B	0N	0P

KIT compuesto por:
- Cartelas Ref.5380
-Tubo rectangular
Ref.4900/12B
-LED de 1m

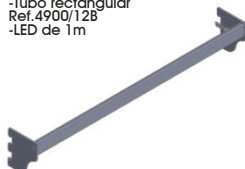

BARRA DE CUELGUE PARA
ACCESORIOS FRONTALES
CON ILUMINACIÓN Y
PROTECCIÓN PLÁSTICA
SUPERIOR

5901/1..

MONTADO

Barre de suspension pour
accessoires avant avec
éclairage
Hanger bar for front
accessories with lighting
Barra appendibili per
accessori frontali con
illuminazione

1M máx.
7
cm

€/u

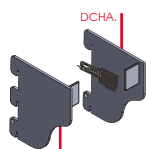

Kit de 2
cartelas:
DERECHA (con
conector) +
IZQUIERDA

**KIT CARTELAS BARRA
ACCESORIOS**
KIT SUPPORT BARRE
ACCESSOIRES
KIT BRACKET FOR
ACCESSORIES ROD
KIT MENSOLA TUBO
PORTA-ACCESSORI

5380/0..

Fe	⊙ 4900	€/u
71 mm medida útil		

o o o



LED no incluido.
LED
recomendado de
5mm de ancho.
Incluye perfil de
plástico superior y
difusor interior.

**TUBO RECTANGULAR PARA
ILUMINACIÓN 30X10MM CON
PLETINA DE REFUERZO**
KIT TUBE RECTANGULAIRE POUR
ECLAIRAGE 30X10MM AVEC
PLAQUE DE RENFORT
KIT RECTANGULAR TUBE FOR
LIGHTING 30X10MM WITH
REINFORCING PLATE
KIT TUBO RETTANGOLARE PER
ILLUMINAZIONE 30X10MM CON
PIASTRA DI RINFORZO

4900/12.

**CON ALMA DE
ACERO INOX**

CARGA LIGERA

Al	⊔ 1 m	€/u
30x10	⊙ 4901	

o o o



182 diodos (20λ);
cortable cada
3.8 cm
Cable, fil. wire,
cavo: 45 mm
Ancho 5mm

flexible y con
cinta adhesiva
fleible and
self-adhesive

**LED CON
MINI-CONECTOR 24V**
BANDE LED AVEC
MINI-PLUG 24V
LED STRIP WITH
MINI-PLUG 24V
STRISCIA LED CON
MINI-PLUG 24V

4901/109

Pla	⊔ 1 m	⚡ 5000 K	€/u
⊙ CRI > 90 ⊕ 15,3W 24V			

PLÁSTICO
PLASTIQUE
PLASTIC
PLASTICA

09

o

EJEMPLO DE APLICACIÓN

Barras de
accesorios con
cuelgue frontal.



**NO APTO PARA
PERROQUET
SOLO GANCHO**

CARGA LIGERA

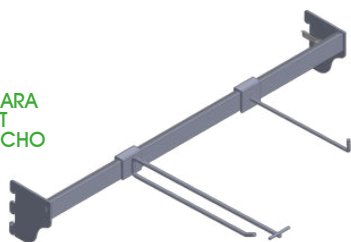



KADÍ PRIMO - ELEKTRIC





INSTAL
ILUMINACIÓN

ALU
SYSTEM

KADÍ ELEKTRIC
PRIMO C.227



ESCANEA ESTE QR
PARA VER TODAS
LAS IMÁGENES DEL
SISTEMA PHARMA



KADÍ
PRIMO
ELEKTRIC

Ejemplos orientativos
de distintas posibilidades,
distribuciones y
aplicaciones



EXPLOSIONADO GENERAL

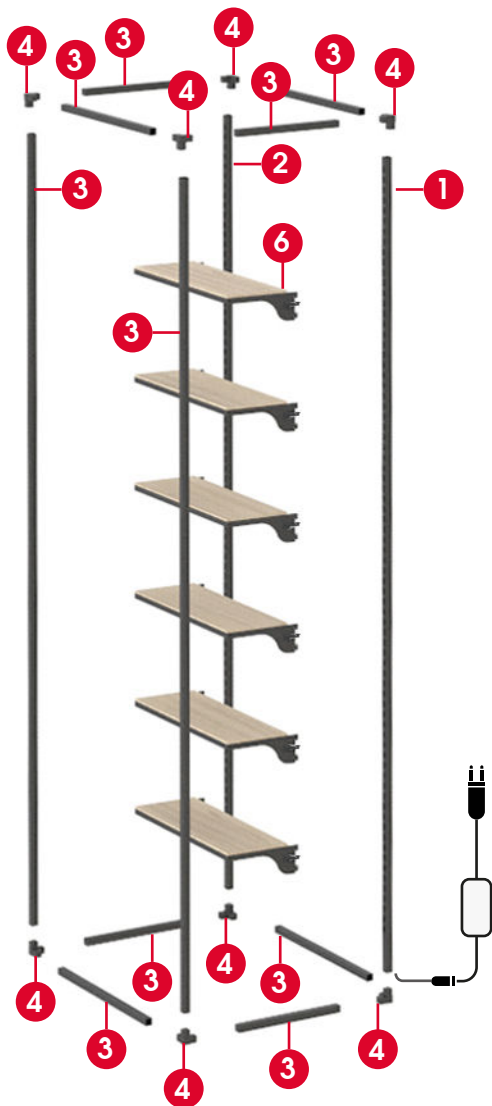

MONTAJE EN SERIE

Colocar las cremalleras **ELECTRIFICADAS** EN EL LADO DERECHO de cada panel

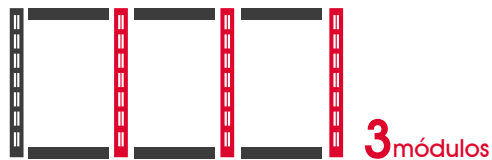

REF: 3960
+ 3961 (CARRIL ELEKTRIC)

Tubos electrificados

Solo los orificios izquierdos (representados en rojo) están electrificados.

REF: 3960

Tubos sin carril eléctrico

1 Tubo primo electrificado - 1 cara
REF: 3960 +3961



2 Tubo primo troquelado 25x25
REF: 3960



3 Tubo sin troquelar 25x25
REF: 3910



4 Nudos



NUEVOS NUDOS



5 Tapones



6 Accesorios

Personalizable:
- Estantes
- Barras
- Perroquets



MONTAJE CON EL SISTEMA -> MAGNETIC

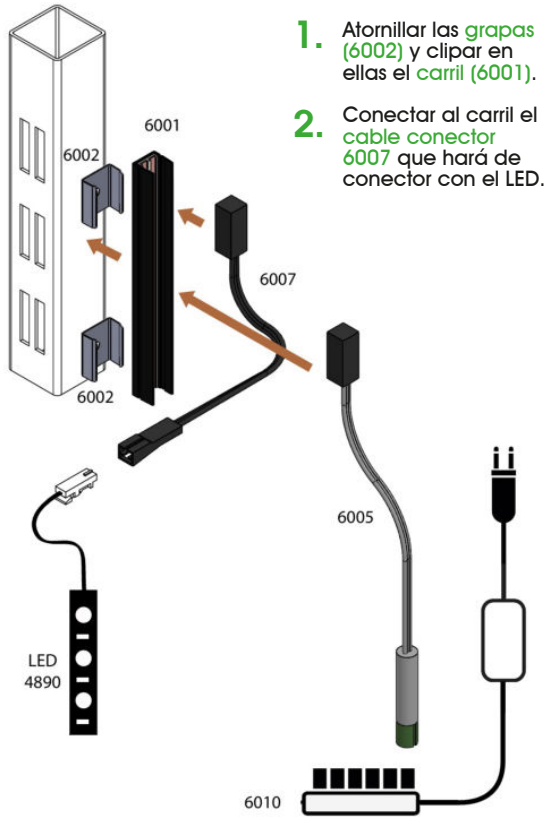

3. Conectar al carril el cable conector 6005 que hará de conector con el driver (6010).

* Los cables conectores se fijan con imán automáticamente al acercar las boquillas imantadas al carril (6001).

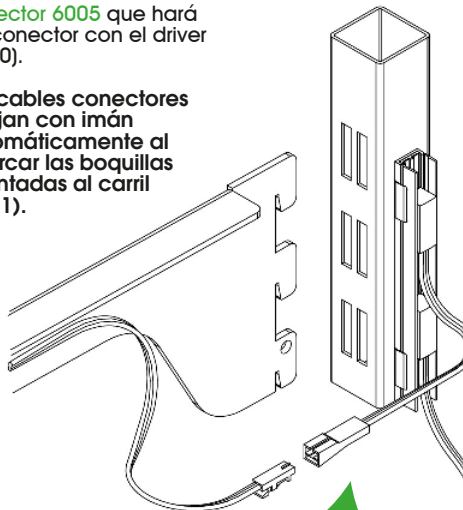

Sistema MAGNETIC colocado en una estructura del sistema PRIMO y con los cables conectores imantados.

MONTAJE CON EL SISTEMA -> EASY

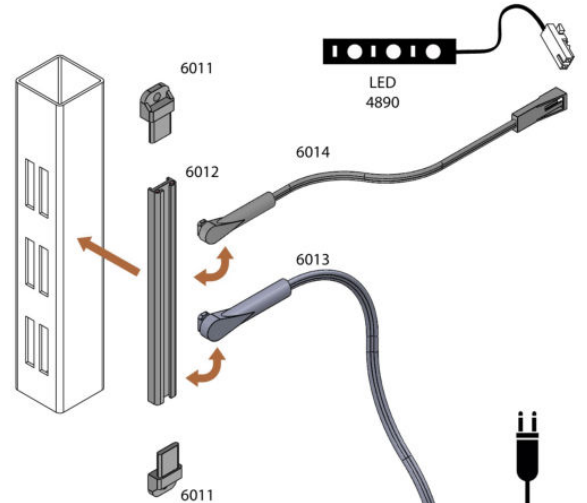

1. Colocar los tapones finales (6011) en los extremos del carril (6012) y colocarlo mediante cinta adhesiva. Atornillar los tapones.

2. Conectar al carril el cable conector 6014 que hará de conector con el LED.

3. Conectar al carril el cable conector 6013 que hará de conector con el driver (6010).

* Los cables conectores entran con la boquilla en perpendicular y al realizar un cuarto de giro (quedando alineados con el carril) quedan totalmente fijados.

Sistema EASY colocado en una estructura del sistema PRIMO y con los cables conectores fijados.

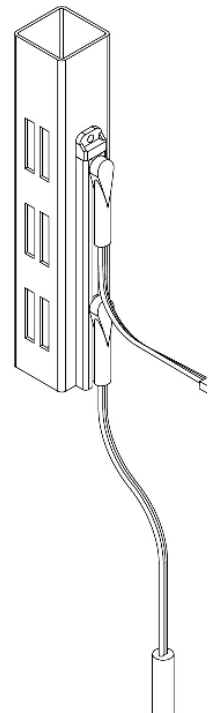

LOS CABLES CONECTORES DEBEN MANTENER TODOS LA MISMA DIRECCIÓN PARA MANTENER LA POLARIDAD





TOPE, GRAPAS Y CABLE

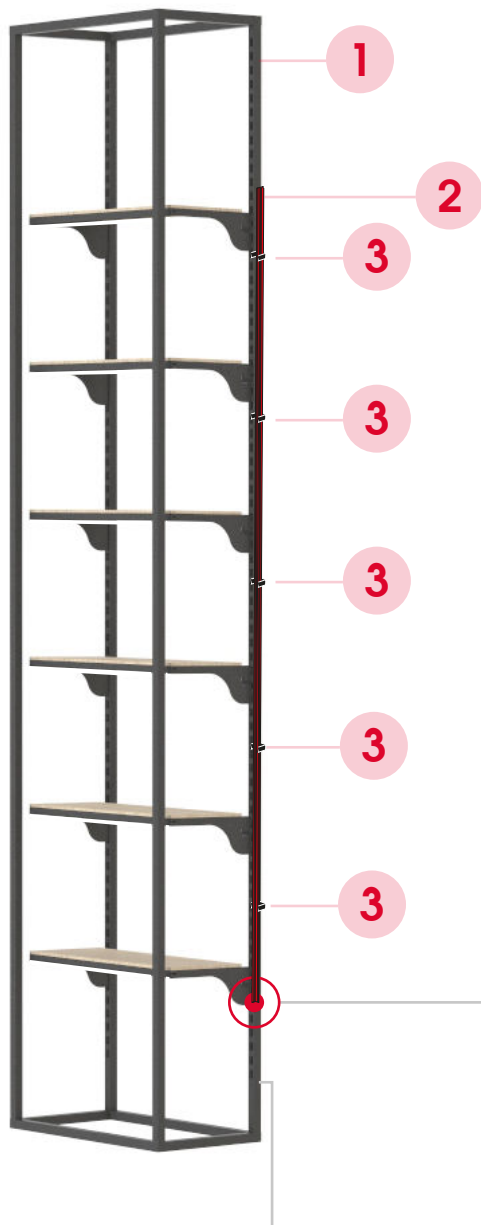

3 Grapas de plástico



- Las grapas deben ir repartidas de manera equitativa
- Colocar entre 4 y 8 grapas dependiendo de la medida.
- Tanto el tubo Primo (1) como el carril electrificado (2) se pueden adaptar a cualquier medida. Posibilidad de cortar.

INICIO DEL CARRIL ELECTRIFICADO

4 Tope inferior

El tope inferior puede colocarse en cualquier orificio de la cremallera

Crea el inicio del carril electrificado

El carril queda apoyado al tope

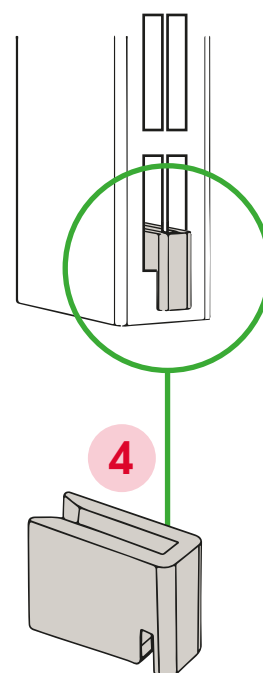

Crear un corte para la salida del cable eléctrico

Tener en cuenta el tipo de unión o nudo que se utilizará para que el orificio no interseccione con la pieza interior

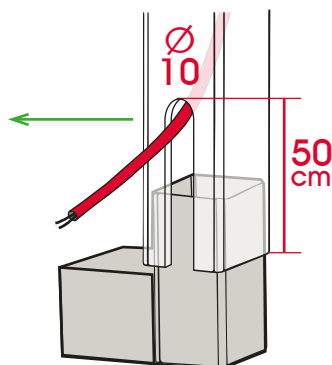



CARRIL ELECTRICO

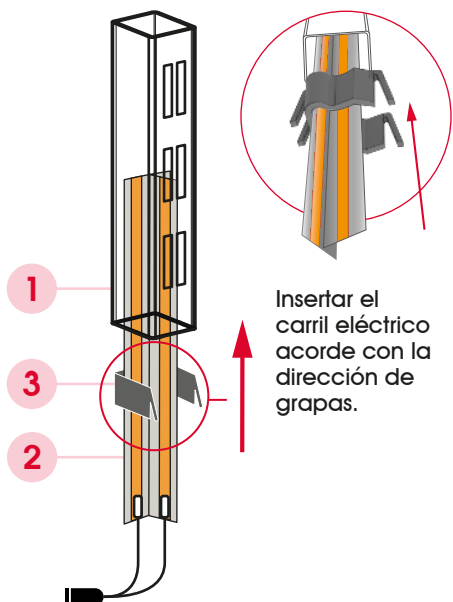

- 1 **Tubo Primo 25x25x1,2** ALTURA 2938
- 2 **Carril eléctrico**
- 3 **Grapas de plástico**
- 4 **Tope inferior**

COLOCACIÓN DEL CONECTOR

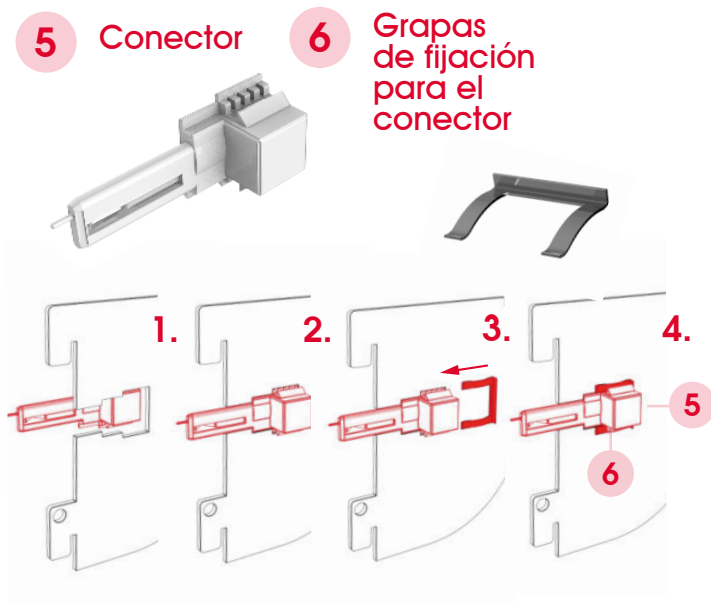

CARRIL-CABLE

• El carril electrificado lleva soldado el cable de conexión en la parte inferior. En el caso de prescindir de este conector, prestar atención a la polaridad de los cables para el correcto funcionamiento de la nueva conexión.

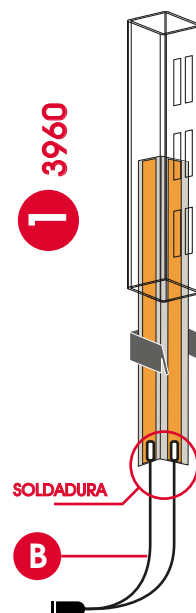



ACCESORIOS PRIMO



Vidrio



Madera



Diferentes materiales y acabados

ESTANTES

CARGA LIGERA



5890..



NUEVO

5891..



NUEVO

CARGA MEDIA



CARGA ALTA



5894..



NUEVO

5896..



NUEVO

5895..



NUEVO

BARRAS

CARGA LIGERA



CARGA MEDIA



5898..



NUEVO

5901..



NUEVO

5897..



NUEVO

PORTA ROTULOS

CARGA LIGERA



5391



NUEVO



TABLA DE PESOS

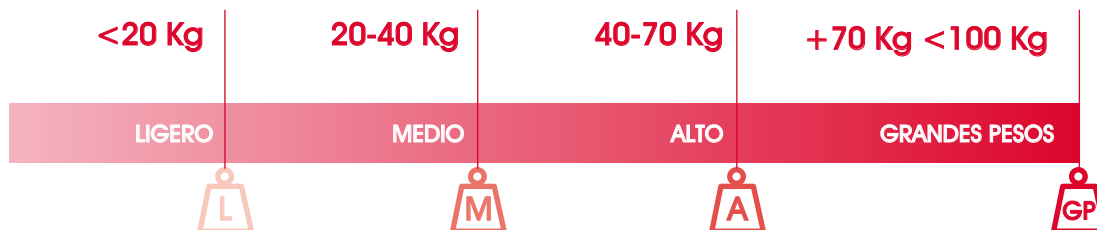

COMPORTAMIENTO DE PESOS

● Puntos conflictivos de carga



La inclinación puede variar dependiendo del peso y la flexibilidad del aluminio.

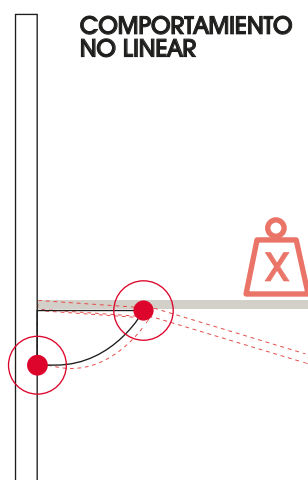
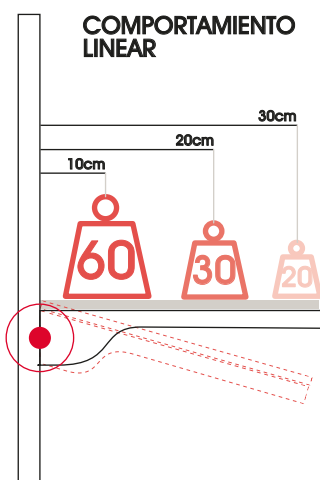

PLUG & PLAY

AL
ENCAJAR
SE ENCIENDE 

Con el sistema PLUG & PLAY el montaje de los módulos de carga resulta fácil, rápido y muy práctico, ya que solo encajando las cartelas a las cremalleras, el circuito eléctrico queda totalmente conectado y el LED encendido.

- FÁCIL
- RÁPIDO
- PRÁCTICO





COMPONENTES POR PIEZA/METRO

CREMALLERAS

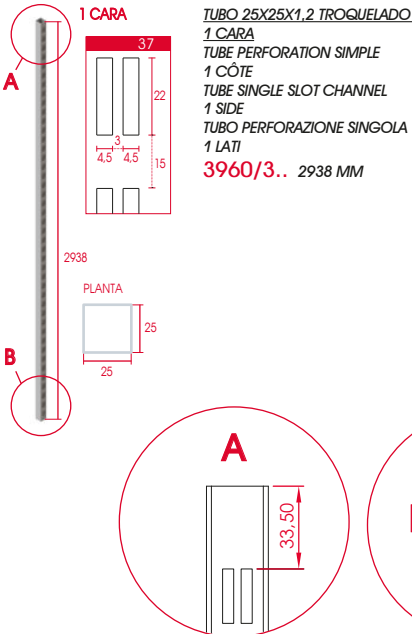

BLANCO BLANC WHITE BIANCO	NEGRO NOIR BLACK NERO	COLOR COULEUR COLOR COLORE
OB	ON	OP
Fe	25x25x1,2mm	€/u

○ ○ ○

DRIVER



6 SALIDAS

DRIVER 100W, 24V / CONECTOR HEMBRA
CONDUCTEUR 100W, 24V / CONNECTEUR FEMELLE
DRIVER 100W, 24V / FEMALE CONNECTOR
DRIVER 100W, 24V / CONNETTORE FEMMINA
6010/009

CABLE CON MINI-CONECTORES 230V
CABLE + MINI PLUG - 230V
CABLE + MINI PLUG - 230V
CAVO + MINI PLUG - 230V
6015/00B

Pla	⚡ 24V 100W	€/u
	15cm	

Pla	⚡ 3m	€/u
	⚡ 230V	2,5 A

PLÁSTICO
PLASTIQUE
PLASTIC
PLASTICA
09

CONECTOR DIVER 6 VÍAS 20CM
CONNECTEUR PLONGEUR
6 VOIES 20CM
6-WAY DIVER CONNECTOR 20CM
CONNETTORE SUBACQUEO A 6 VIE 20 CM
6021/009

CABLE ALARGO MACHO-HEMBRA 3M
CÂBLE D'EXTENSION MÂLE-FEMELLE DE 3 M
3M MALE-FEMALE EXTENSION CABLE
CAVO DI PROLUNGA MASCHIO-FEMMINA 3M
6022/00B

CON CONECTOR NUEVO

Pla	⚡ 3m	€/u
	⚡ 230V	2,5 A

Pla	⚡ 3m	€/u
	⚡ 230V	2,5 A

CABLES



CABLE MINI PLUG - ABIERTO 24V
CABLE MINI PLUG - OVERTE 24V
CABLE MINI PLUG - OPEN ENDED 24V
CAVO MINI PLUG - APERTO 24V
4888/009

Pla	⚡ 400m	€/u
	⚡ 24V	2,5 A

EASY



Para instalaciones móviles permite quitar y poner **MAGNÉTICO**

CARRIL ELECTRIFICADO
RAIL ÉLECTRIFIÉ
ELECTRIFIED RAIL
BINARIO ELETRIFICATO
MAGNETICO
6012/25.

⚡ 2,5 m	⚡ 24V	€/u
---------	-------	-----

CINTA MAGNÉTICA ADHESIVA
RUBAN MAGNÉTIQUE ADHÉSIF
ADHESIVE MAGNETIC TAPE
NASTRO MAGNETICO ADESIVO
6012/000 50M
6012/100 1M

PLÁSTICO
PLASTIQUE
PLASTIC
PLASTICA
09

CINTA ADHESIVA DOBLE CARA
RUBAN MAGNÉTIQUE ADHÉSIF
ADHESIVE MAGNETIC TAPE
NASTRO MAGNETICO ADESIVO
6012/009 66M

CONECTOR CARRIL-DRIVER / CONECTOR SEGURIDAD ALUSYSTEM
CONNECTEUR RAIL-DRIVER / CONNECTEUR SECURITÉ DU ALUSYSTEM
CONNECTOR RAIL-DRIVER / CONNECTOR ALUSYSTEM SECURITY
CONNETTORE RAIL-DRIVER / CONNETTORE LA SICUREZZA ALUSYSTEM
6013/0..

Pla	⚡ 24V	€/u
	1M	

CONECTOR CARRIL-LED / HEMBRA
CONNECTEUR RAIL-LED / FEMELLE
RAIL-LED CONNECTOR / FEMALE
CONNETTORE RAIL-LED / FEMMINA
6014/0..

Pla	⚡ 24V	€/u
	10cm	

TAPÓN FINAL
BOUCHON D'EXTRÉMITÉ
END CAP
TAPPO TERMINALE
6011/0.. SET 2 U.

€/u	
-----	--

MAGNETIC LED

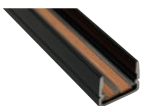

MAGNÉTICO



CARRIL ELECTRIFICADO
MAGNÉTICO
RAIL ÉLECTRIFIÉ MAGNÉTIQUE
MAGNETIC ELECTRIFIED RAIL
BINARIO ELETRIFICATO
MAGNETICO
6001/20N

INOX	SAT	NEGRO
INOX	SAT	NOIR
S.S.S.	SAT	BLACK
INOX	SAT	NERO
28	ON	
⚡ 2 m	€/u	

Ⓞ 6001-6012	€/u
-------------	-----

CLIP PARA FIJACIÓN
CLIP DE FIXATION
FIXING CLIP
CLIP DI FISSAGGIO
6002/028

Ⓞ 6001-6012	€/u
-------------	-----



MAGNÉTICO

CONECTOR MAGNÉTICO
CARRIL-DRIVER
CONNECTEUR MAGNÉTIQUE
RAIL-DRIVER
MAGNETIC CONNECTOR
RAIL-DRIVER
CONNETTORE MAGNETICO
RAIL-DRIVER
6005/00N

Pla	⚡ 2A	€/u
	150cm	



MAGNÉTICO

CONECTOR MAGNÉTICO
CARRIL-CONECTOR CARTELAS KADI
CONNECTEUR MAGNÉTIQUE
RAIL-CONNECTEUR SUPPORT KADI
MAGNETIC CONNECTOR
RAIL-CONNECTOR KADI BRACKET
CONNETTORE MAGNETICO BINARIO
- CONNETTORE MENSOLA KADI
6006/00N

Pla	⚡ 2A	€/u
	40cm	



MAGNÉTICO

CONECTOR MAGNÉTICO
CARRIL-LED UNIVERSAL
CONNECTEUR MAGNÉTIQUE
RAIL-LED UNIVERSAL
MAGNETIC CONNECTOR
RAIL-UNIVERSAL LED
CONNETTORE MAGNETICO
BINARIO-UNIVERSALE LED
6007/00N

Pla	⚡ 2A	€/u
	40cm	



(X2 u.)



COMPONENTES POR PIEZA/METRO

KITS CARRIL ELECTRIFICADO

PL. M
ALU. M
ALL. NAT
01

KIT 1 CARA



KIT PERFIL DE ALUMINIO ELECTRIFICADO A UNA CARA CON GRAPAS DE PLÁSTICO
KIT PROFILÉ ALUMINIUM ÉLECTRIFIÉ D'UN CÔTÉ AVEC DES AGRAFES EN PLASTIQUE
KIT ALUMINIUM PROFILE ELECTRIFIED ON ONE SIDE WITH PLASTIC STAPLES
KIT PROFILO IN ALLUMINIO ELETRIFICATO SU UN LATO CON GRAFFE IN PLASTICA

3961/241 240 CM
3961/181 180 CM
3961/121 120 CM

Al 22x13 mm €/u

*o
*o
*o

Nº COMPONENTES/MEDIDA

MEDIDA	240 cm	180 cm	120 cm
Grapas	X8 uds	X6 uds	X4 uds
Carril electrificado	1 carril de 240	1 carril de 180	1 carril de 120
Tope inferior	X1 ud	X1 ud	X1 ud

SISTEMA DE FÁCIL CONEXIÓN - PLUG & PLAY

KIT CARRIL ELECTRIFICADO

PL. M
ALU. M
ALL. NAT
01

KIT 1 CARA



Longitud cable 1m.

Gesls® GST0812G

KIT PERFIL DE ALUMINIO ELECTRIFICADO A UNA CARA CON GRAPAS DE PLÁSTICO
KIT PROFILÉ ALUMINIUM ÉLECTRIFIÉ D'UN CÔTÉ AVEC DES AGRAFES EN PLASTIQUE
KIT ALUMINIUM PROFILE ELECTRIFIED ON ONE SIDE WITH PLASTIC STAPLES
KIT PROFILO IN ALLUMINIO ELETRIFICATO SU UN LATO CON GRAFFE IN PLASTICA

3961/241 240 CM
3961/181 180 CM
3961/121 120 CM

Al 22x13 mm €/u

*o
*o
*o

Nº COMPONENTES/MEDIDA

MEDIDA	240 cm	180 cm	120 cm
Grapas	X8 uds	X6 uds	X4 uds
Carril electrificado	1 carril de 240	1 carril de 180	1 carril de 120
Tope inferior	X1 ud	X1 ud	X1 ud
Conector Gesls	X1 ud	X1 ud	X1 ud

CONECTORES COMPATIBLE KADÍ PHARMA

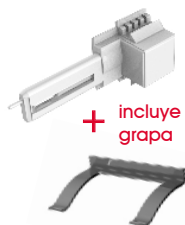

+ incluye grapa

CONECTOR PLUG & PLAY, BLANCO / NEGRO
CONNECTEUR PLUG & PLAY, BLANC / NOIR
CONNECTOR PLUG & PLAY, WHITE / BLACK
CONNETTORE PLUG & PLAY, BIANCO / NERO

84864/OOB
84864/OON

PLÁSTICO
PLASTIQUE
PLASTIC
PLASTICA
09

Pla 1 m
CE IP20

24V max.3A €/u

*o
*o

Cualquier manipulación invalida la garantía del fabricante





NUDOS PRESIÓN



NUDO 3 VIAS
JOINT À 3 VOIES
3 WAY JOINT
GIUNTO 3 VIE
3900/0..

NUDO 3 VIAS + ROSCAMI10
JOINT À 3 VOIES + TROU M10
3 WAY JOINT + M10 HOLE
GIUNTO 3 VIE + FORO M10
3901/0..

NUDO 4 VIAS
JOINT À 4 VOIES
4 WAY JOINT
GIUNTO 4 VIE
3902/0..

NUDO 4 VIAS + ROSCAMI10
JOINT À 4 VOIES + TROU M10
4 WAY JOINT + M10 HOLE
GIUNTO 4 VIE + FORO M10
3903/0..

NUDO 5 VIAS
JOINT À 5 VOIES
5 WAY JOINT
GIUNTO 5 VIE
3904/0..

NUDO 3 VIAS "T"
JOINT À 3 VOIES "T"
"T" 3 WAY JOINT
GIUNTO 3 VIE "T"
3907/0..

NUDO 2 VIAS
JOINT À 2 VOIES
2 WAY JOINT
GIUNTO 2 VIE
3905/0..

CR. BILLO CH. FOU BR. CHR CR. ILLC.	BLANCO WHITE BIANCO	NEGRO BLACK NERO	COLOR COULEUR COLOR COLORE		
32	OB	ON	OP		
Zn	25x25 mm			€/u	
		○	○	○	
Zn	25x25mm			€/u	
		○	○	○	
Zn	25x25 mm			€/u	
		○	○	○	
Zn	25x25mm M10			€/u	
		○	○	○	
Zn	25x25mm			€/u	
		○	○	○	
Zn	20x20mm			€/u	
		○	○	○	
Zn	25x25mm			€/u	
		○	○	○	

NUDOS BRIDA



NUDO 3 VIAS
JOINT À 3 VOIES
3 WAY JOINT
GIUNTO 3 VIE
3980/0..

NUDO 4 VIAS
JOINT À 4 VOIES
4 WAY JOINT
GIUNTO 4 VIE
3982/0..

NUDO 4 VIAS
JOINT À 4 VOIES
4 WAY JOINT
GIUNTO 4 VIE
3988/0..

NUDO 5 VIAS
JOINT À 5 VOIES
5 WAY JOINT
GIUNTO 5 VIE
3984/0..

NUDO 6 VIAS
JOINT À 6 VOIES
6 WAY JOINT
GIUNTO 6 VIE
3986/0..

NUDO 3 VIAS "T"
JOINT À 3 VOIES "T"
"T" 3 WAY JOINT
GIUNTO 3 VIE "T"
3987/0..

NUDO 2 VIAS
JOINT À 2 VOIES
2 WAY JOINT
GIUNTO 2 VIE
3985/0..

TUBO 25X25 mm
TUBE 25X25 mm
TUBE 25x25 mm
TUBO 25x25 mm
3989/0..

CR. BILLO CH. FOU BR. CHR CR. ILLC.	BLANCO WHITE BIANCO	NEGRO BLACK NERO	COLOR COULEUR COLOR COLORE		
32	OB	ON	OP		
Zn	25x25 mm			€/u	
		○	○	○	
Zn	25x25 mm			€/u	
		○	○	○	
Zn	25x25 mm			€/u	
		○	○	○	
Zn	25x25mm			€/u	
		○	○	○	
Zn	25x25mm			€/u	
		○	○	○	
Zn	20x20mm			€/u	
		○	○	○	
Zn	25x25mm			€/u	
		○	○	○	
				Fe	25x25x1,2 €/u
		○	○	○	
Fe	25x25 mm			€/u	
		○	○	○	
Zn	25x25 mm M10			€/u	
				PL.NEGRO	
		○	○		
Zn	25x25 mm			€/u	
				PL.NEGRO	
		○	○		
Zn	25x25 mm			€/u	
		○	○	○	
Fe	L 3 m	25x25x1,2		€/u	
		○	○	○	

OTROS ACCESORIOS

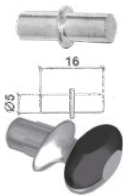

PORTAESTANTE TUBULAR
PORTE-ÉTAGÈRE TUBULAIRE
TUBULAR SHELF HOLDER
PORTA RIPIANO TUBOLARE
3933/032



PESTAÑA ESTANTE ANTIDESLIZANTE
SHELF SUPPORT
TAQUET
REGGIPIANO
3824/032



PINZA ESTANTE VIDRIO BLOQUEO SEGURIDAD
TAQUET MÉTALLIQUE AUTOBLOQUANT VERRE
METALLIC GLASS SHELF-BLOCKING HOLDER
REGGICRISTALLO CON BLOCCO
1440/032



VENTOSA
VENTOUSE
SUCTION
VENTOSA
2556/009



VENTOSA
VENTOUSE
SUCTION
VENTOSA
319/009



NIVELADOR M10
VÉRIN M10
LEVELLER M10
PIEDINO LIVELLATORE M10
3813/00N



RUEDA M10
ROUE
CASTOR
RUOTA
232/00N

Fe	Ø 5 mm	16 mm		€/u	
			○		
Zn	Ø 5 mm			€/u	
			○		
				Zn	5-8 mm
					Ø 5 mm
			○		
plas	Ø14	7	3922	€/u	
					○
plas	Ø20	7	3922	€/u	
					○
plas	M10			€/u	
					○
plas	M10 Ø50	30kg/u		€/u	
					○

TAPONES

CR.NEGRO



PL.NEGRO



PL.NEGRO



TAPÓN TUBO 25X25
EMBOUIT
END-CAP
COPRITESTA
3911/032

TAPÓN M10 TUBO 20X20
END-CAP with M10 hole
EMBOUIT avec m10 trou
COPRITESTA con foro M10
3912/000

ANCLAJE TUBO 25X25
FIXATION TUBE
TUBO FIXING
FISSAGGIO TUBO
3929/032

TUBO 25X25



TUBO 25X25 mm
TUBE 25x25 mm
TUBE 25x25 mm
TUBO 25x25 mm
3910/3..



PORTA

RÓTULOS 5391/1..

* MADERA NO INCLUIDA

COMPATIBLE
KADÍ PRIMO



MATERIAL RÓTULO *
NO INCLUIDO

CARTELA CON CONECTOR
PARA LETREROS CON
ILUMINACIÓN
5391/0..

SIN MONTAJE

Placard avec
connecteur pour
enseignes lumineuses.
Placard with connector
for illuminated signs.
Cartello con connettore
per insegne luminose.

1M máx.
 7
cm

Fe 72 mm medida útil

BLANCO BLANC WHITE BIANCO	NEGRO NOR BLACK NERO	COLOR COULEUR COLOR COLORE
OB	ON	OP

<input type="radio"/>	<input type="radio"/>	<input type="radio"/>
-----------------------	-----------------------	-----------------------

€/u

ESTANTE

MADERA 5896/1..

COMPATIBLE
KADÍ PRIMO



MADERA *
NO INCLUIDA

ESTANTE DE MADERA
CON ILUMINACIÓN
FRONTAL EMPOTRADA
Y PERFIL DE ALUMINIO
5896/1..

SIN MONTAJE

Étagère en bois avec
éclairage zénithal monté sur
étagère
Wooden shelf with zenithal
lighting mounted on the shelf
Ripiano legno con
illuminazione zenitale
impotrata nel ripiano

1M máx.
 28
cm

PL. M ALU. M ALU. M ALL. NAT	BLANCO WHITE BIANCO	NEGRO BLACK NERO	COLOR COULEUR COLOR COLORE
O1	OB	ON	OP

<input type="radio"/>	<input type="radio"/>	<input type="radio"/>
-----------------------	-----------------------	-----------------------

€/u

SISTEMA CUT-LINE

SISTEMA DE PERFIL DE ALUMINIO CON LED
INCORPORADO

SE PUEDE ENCASTRAR A LA MADERA O AUTOADHESIVAR

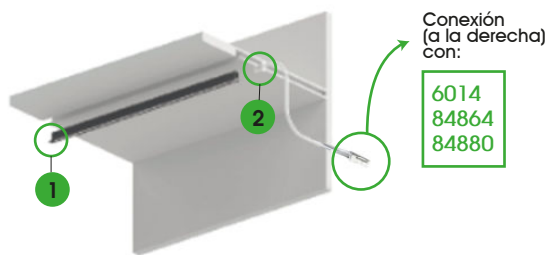

Conexión
(a la derecha)
con:

6014
84864
84880

CORTE TOTALMENTE LIBRE,
SIN LIMITES DE MEDIDAS

SE CORTA TODA LA ESTRUCTURA Y EL LED
A LA MEDIDA DESEADA Y SE REMATA
CON LOS TAPONES FINALES POR AMBOS LADOS



1 Tapón simple / 2 Tapón con
conexión (derecha)

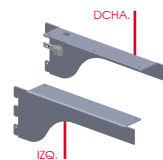

Kit 2 tarjetas:
DERECHA (con
conector) +
IZQUIERDA

KIT CARTELAS ESTANTE MADERA
CON ILUMINACIÓN
KIT SUPPORTS BOIS ILLUMINATION
WOOD LIGHTING BRACKETS KIT
KIT MENSOLE LEGNO
ILLUMINAZIONE

5381/0..

Fe	4890	€/u
	282 mm medida útil	

<input type="radio"/>	<input type="radio"/>	<input type="radio"/>
-----------------------	-----------------------	-----------------------



Medidas
mecanizado
16 x 6.8 mm

KIT PERFIL ALUMINIO CON
DIFUSOR
KIT PROFIL EN ALUMINIUM
AVEC DIFFUSEUR
KIT PROFILO IN ALLUMINIO
CON DIFFUSORE

3971/1..

Al	2M	18x9mm	€/m
----	----	--------	-----

<input type="radio"/>

DIFERENTES POSICIONES DEL DIFUSOR (RECTO / INCLINADO)

PERFIL DE ALUMINIO CON LED
INCORPORADO
PROFILÉ EN ALUMINIUM AVEC LED
INTÉGRÉE
ALUMINIUM PROFILE WITH BUILT-IN LED
PROFILO IN ALLUMINIO CON LED
INTEGRATO

6025/301 4000K
6026/301 5000K

SET CONECTOR + TAPA
CABLE 40CM
6030/041

GRAPAS
6031/041

Pla	3 m	€/u
	CRI>90	9,6W/24V



126 diodos (20λ);
cortable cada
5.5 cm.
Cable, fil. wire,
cavo; 40cm
Ancho 8 mm

flexible y con
cinta adhesiva
fleible and
self-adhesive

LED CON MINI-CONECTOR
24V
BANDE LED AVEC MINI-PLUG
24V
LED STRIP WITH MINI-PLUG
24V
STRIACIA LED CON
MINI-PLUG 24V

4890/009

Pla	1 m	5000 K	€/u
	CRI>90	9,6 W 24V	

<input type="radio"/>



ESTANTE

VIDRIO 5895/1..

* Recomendamos usar vidrios segurizados o laminados. (NO INCLUIDO)

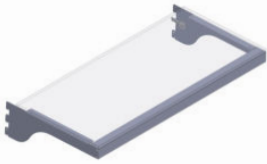

VIDRIO NO INCLUIDO *

ESTANTE DE VIDRIO CON ILUMINACIÓN FRONTAL
5895/1..

MONTADO

Étagère en verre avec éclairage avant
Glass shelf with front lighting
Ripiano vetro con illuminazione frontale

1M máx. 29 cm

PARA MADERA O VIDRIO



€/u

PL. M	BLANCO	NEGRO	COLOR
ALU. M	BLANC	NOIR	COULEUR
ALU. M	WHITE	BLACK	COLOR
ALL. NAT	BANCO	NERO	COLORE
01	0B	0N	0P

ESTANTE

VIDRIO 5894/1..

ESTANTE DE VIDRIO CON ILUMINACIÓN CENITAL FRONTAL
5894/1..

MONTADO

Étagère en verre avec éclairage zenithal frontal
Glass shelf with frontal zenithal lighting
Ripiano di vetro con illuminazione zenitale frontale

1M máx. 27 cm

PARA MADERA O VIDRIO



€/u

PLÁSTICO	BLANCO	NEGRO	COLOR
PLASTIQUE	BLANC	NOIR	COULEUR
PLASTIC	WHITE	BLACK	COLOR
PLASTICA	BANCO	NERO	COLORE
09	0B	0N	0P

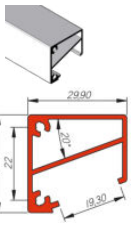

PERFIL ALUMINIO
PROFIL EN ALUMINIUM
ALUMINIUM PROFILE
PROFILO DI ALUMINIO
4744/1..

Al		5 m	30x30	€/m
Ⓞ 84602				

o o o o

Pla		2 m	Ⓞ 4744	€/m
-----	--	-----	--------	-----

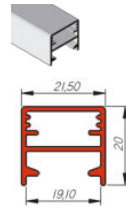

PERFIL ALUMINIO
PROFIL EN ALUMINIUM
ALUMINIUM PROFILE
PROFILO DI ALUMINIO
4748/1..

Al		6 m	21,5x20	€/m
Ⓞ 4893				

o o o

Pla	Ⓞ 4892 - 4894	€/m
2 m		



DIFUSOR PLÁSTICO MATE
DIFFUSEUR EN PLASTIQUE MAT
MATT PLASTIC DIFFUSOR
DIFUSORE PLASTICO OPACO
84602/109

PLÁSTICO	PLASTIQUE	PLASTIC	PLASTICA
09	o		

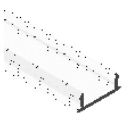

DIFUSOR PLÁSTICO MATE
DIFFUSEUR EN PLASTIQUE MAT
MATT PLASTIC DIFFUSOR
DIFUSORE PLASTICO OPACO
4893/109

o

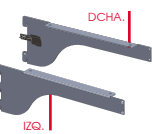

KIT CARTELAS ESTANTE VIDRIO CON ILUMINACIÓN
KIT SUPPORTS VERRE
ILLUMINATION
GLASS LIGHTING BRACKETS KIT
KIT MENSOLE VETRO
ILLUMINAZIONE
3862/0..

Fe	Ⓞ 4744-2556-4890	€/u
292 mm medida útil		

o o o

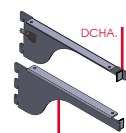

KIT CARTELAS ESTANTE VIDRIO CON ILUMINACIÓN
KIT SUPPORTS VERRE
ILLUMINATION
GLASS LIGHTING BRACKETS KIT
KIT MENSOLE VETRO
ILLUMINAZIONE
5385/0..

Fe	Ⓞ 4744-2556-4890	€/u
270 mm medida útil		

o o o

Cada cartela tiene 2 taladros para usar 1 perfil 4744

Kit 2 cartelas: DERECHA (con conector) + IZQUIERDA



126 diodos (20λ); cortable cada 5.5 cm
Cable, fil, wire, cavo; 26cm
Ancho 8mm

flexible y con cinta adhesiva
flexible and self-adhesive

LED CON MINI-CONECTOR 24V
BANDE LED AVEC MINI-PLUG 24V
LED STRIP WITH MINI-PLUG 24V
STRACIA LED CON MINI-PLUG 24V
4890/109

Pla		1 m	⚡ 5000 K	€/u
Ⓞ CRI>90 Ⓞ 9,6 W 24V				

o



126 diodos (20λ); cortable cada 5.5 cm
Cable, fil, wire, cavo; 26cm
Ancho 8mm

flexible y con cinta adhesiva
flexible and self-adhesive

LED CON MINI-CONECTOR 24V
BANDE LED AVEC MINI-PLUG 24V
LED STRIP WITH MINI-PLUG 24V
STRACIA LED CON MINI-PLUG 24V
4890/109

Pla		1 m	⚡ 5000 K	€/u
Ⓞ CRI>90 Ⓞ 9,6 W 24V				

o



VENTOSA TRANSPARENTE
VENTOUSE
SUCITON
VENTOSA
2556/009

Pla	⌀ 14 mm	Ⓞ 4880	€/u
-----	---------	--------	-----

o



VENTOSA TRANSPARENTE
VENTOUSE
SUCITON
VENTOSA
2556/009

Pla	⌀ 14 mm	Ⓞ 4880	€/u
-----	---------	--------	-----

o



***ESTANTE**

VIDRIO 5890/1..

* Recomendamos usar vidrios securizados o laminados. (NO INCLUIDO)



VIDRIO * NO INCLUIDO

ESTANTE DE VIDRIO RETROILUMINADO *5890/1..

MONTADO

Étagère en verre extra claire rétro-éclairé
Blacklit optical glass shelf
Ripiano vetro extralight retroilluminato

1M máx. 30 cm

€/u

PL. M	BLANCO	NEGRO	COLOR
ALU. M	BLANC	NOIR	COULEUR
ALL. M	WHITE	BLACK	COLOR
ALL. NAT	BANCO	NERO	COLORE
01	0B	0N	0P

***ESTANTE**

VIDRIO 5891/1..



VIDRIO * NO INCLUIDO

ESTANTE DE VIDRIO CON ILUMINACIÓN FRONTAL *5891/1..

MONTADO

Étagère en verre avec éclairage zénithal frontal
Glass shelf with frontal zenithal lighting
Ripiano di vetro con illuminazione zenitale frontale

1M máx. 30 cm

€/u

PL. M	BLANCO	NEGRO	COLOR
ALU. M	BLANC	NOIR	COULEUR
ALL. M	WHITE	BLACK	COLOR
ALL. NAT	BANCO	NERO	COLORE
01	0B	0N	0P



Junta goma incluida
joint en caoutchouc
inclus rubber gasket
includet giunta di gomma inclusa

PERFIL ALUMINIO PROFIL LAME D'ALUMINIUM ALUMINIUM SLATWALL PROFILE PROFILO DOGATO ALLUMINIO *362/1...

Al	5 m	6-8mm	€/m
	361/109		

*o *o *o *o

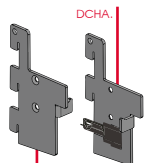

Con perfil 362
Kit 2 carterías: DERECHA (con conector) + IZQUIERDA

KIT CARTELAS ESTANTE VIDRIO CON ILUMINACIÓN KIT SUPPORTS VERRE ILLUMINATION GLASS LIGHTING BRACKETS KIT KIT MENSOLE VETRO ILLUMINAZIONE *5384/0..

Fe	362 - 4890	€/u
	53 mm medida útil	

*o *o *o



126 diodos (20λ); cortable cada 5.5 cm Cable, fil, wire, cavo: 26cm Ancho 8mm flexible y con cinta adhesiva feible and self-adhesive

LED CON MINI-CONECTOR 24V BANDE LED AVEC MINI-PLUG 24V LED STRIP WITH MINI-PLUG 24V STRIACIA LED CON MINI-PLUG 24V *4890/109

Pla	1 m	5000 K	€/u
	CRI>90	9,6 W 24V	

PLÁSTICO PLASTIQUE PLASTIC PLASTICA 09

o



PERFIL ALUMINIO PROFIL EN ALUMINIUM ALUMINIUM PROFILE PROFILO DI ALLUMINIO *4892/1..

Al	5 m	32x11,2	€/m
	4893 - 4894		

o o o o

DIFUSOR DE PLÁSTICO MATE DIFFUSEUR EN PLASTIQUE MAT MATT PLASTIC DIFFUSOR DIFUSORE PLASTICO OPACO *4893/109

Pla	4892 - 4894	€/m
	2 m	

o

KIT TAPAS FINALES LATERALES COUVERTURE LATÉRALE FINALE LATERAL END CAP COPERTURA LATERALE FINALE *4894/0..

Pla	32x11,2 mm	€/u
	4892	

o o

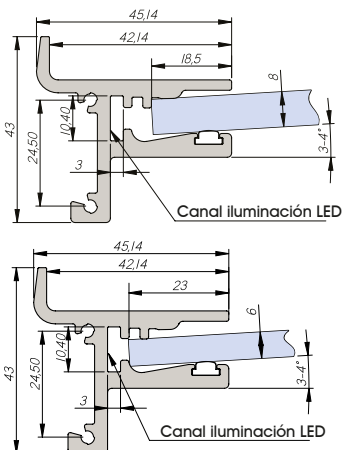

ES • MÁXIMA MEDIDA ESTANTE RECOMENDADA: 100 X 30 CM.

FR • Maximum recommended shelf size: 100 x 30 cm.

IT • Dimensione massima raccomandata dello scaffale: 100 x 30 cm.

EN • Taille maximale de l'étagère recommandée: 100 x 30 cm.



PENDERIE 5897/1..

* MADERA NO INCLUIDA

KIT compuesto por:
- Cartelas Ref.5382
-Tubo rectangular Ref.4900/12B
-LED de 1m



VIDRIO / MADERA NO INCLUIDO

ESTANTE + BARRA DE CUELGUE LATERAL CON ILUMINACIÓN Y PROTECCIÓN PLÁSTICA SUPERIOR 5897/1..

MONTADO

Tablette + barre de suspension laterale avec éclairage
Shelf + side hanging bar with lighting
Mensola + barra appendiabiti laterale con illuminazione

1M máx. 29 cm

PARA MADERA O VIDRIO

PLÁSTICO	BLANCO	NEGRO	COLOR
PLASTIQUE	BLANC	NOR	COULEUR
PLASTICA	WHITE	BLACK	COLOR
PLASTICA	BIANCO	NERO	COLORE
09	OB	ON	OP

BARRA DE CUELGUE LATERAL 5898/1..

KIT compuesto por:
- Cartelas Ref.5383
-Tubo rectangular Ref.4900/12B
-LED de 1m



BARRA DE CUELGUE LATERAL CON ILUMINACIÓN Y PROTECCIÓN PLÁSTICA SUPERIOR 5898/1..

MONTADO

Barre de suspension laterale avec éclairage
Side hanging bar with lighting
Barra appendiabiti laterale con illuminazione

1M máx. 29 cm

PL. M	BLANCO	NEGRO	COLOR
ALU. M	BLANC	NOR	COULEUR
ALU. M	WHITE	BLACK	COLOR
ALL. NAT	BIANCO	NERO	COLORE
01	OB	ON	OP

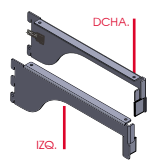

DCHA.

IZQ.

Kit 2 cartelas: DERECHA (con conector) + IZQUIERDA

KIT CARTELAS BARRA ACCESORIOS
KIT SUPPORT BARRE ACCESSOIRES
KIT BRACKET FOR ACCESSORIES ROD
KIT MENSOLA TUBO PORTA-ACCESSORI 5382/00.

Fe	⊙ 4900	€/u
	290 mm medida útil	

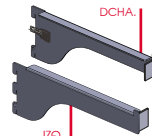

DCHA.

IZQ.

Kit 2 cartelas: DERECHA (con conector) + IZQUIERDA

KIT CARTELAS BARRA ACCESORIOS
KIT SUPPORT BARRE ACCESSOIRES
KIT BRACKET FOR ACCESSORIES ROD
KIT MENSOLA TUBO PORTA-ACCESSORI 5383/00.

Fe	⊙ 4900	€/u
	290 mm medida útil	

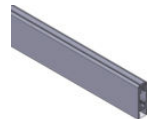

LED no incluido. LED recomendado de 5mm de ancho. Incluye perfil de plástico superior y difusor interior.

TUBO RECTANGULAR PARA ILUMINACIÓN 30X10MM CON PLETINA DE REFUERZO
KIT TUBE RECTANGULAIRE POUR ECLAIRAGE 30X10MM AVEC PLAQUE DE RENFORT
KIT RECTANGULAR TUBE FOR LIGHTING 30X10MM WITH REINFORCING PLATE
KIT TUBO RETTANGOLARE PER ILLUMINAZIONE 30X10MM CON PIASTRA DI RINFORZO 4900/12.

CON ALMA DE ACERO INOX

CARGA LIGERA max. 30KG

Al	⊔ 1 m	30x10	€/u
	⊙ 4901		

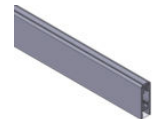

LED no incluido. LED recomendado de 5mm de ancho. Incluye perfil de plástico superior y difusor interior.

TUBO RECTANGULAR PARA ILUMINACIÓN 30X10MM CON PLETINA DE REFUERZO
KIT TUBE RECTANGULAIRE POUR ECLAIRAGE 30X10MM AVEC PLAQUE DE RENFORT
KIT RECTANGULAR TUBE FOR LIGHTING 30X10MM WITH REINFORCING PLATE
KIT TUBO RETTANGOLARE PER ILLUMINAZIONE 30X10MM CON PIASTRA DI RINFORZO 4900/12.

CON ALMA DE ACERO INOX

CARGA LIGERA max. 30KG

Al	⊔ 1 m	30x10	€/u
	⊙ 4901		



182 diodos (20λ); cortable cada 3.8 cm
Cable, fil. wire, cavo: 40cm
Ancho 5mm

flexible y con cinta adhesiva
fleible and self-adhesive

LED CON MINI-CONECTOR 24V

BANDE LED AVEC MINI-PLUG 24V
LED STRIP WITH MINI-PLUG 24V

STRIACIA LED CON MINI-PLUG 24V 4910/109

Pla	⊔ 1 m	⚡ 5000 K	€/u
	⊙ CRI>90	⊖ 15,3W 24V	



182 diodos (20λ); cortable cada 3.8 cm
Cable, fil. wire, cavo: 40cm
Ancho 5mm

flexible y con cinta adhesiva
fleible and self-adhesive

LED CON MINI-CONECTOR 24V

BANDE LED AVEC MINI-PLUG 24V
LED STRIP WITH MINI-PLUG 24V

STRIACIA LED CON MINI-PLUG 24V 4910/109

Pla	⊔ 1 m	⚡ 5000 K	€/u
	⊙ CRI>90	⊖ 15,3W 24V	

PLÁSTICO
PLASTIQUE
PLASTICA
09



VENTOSA TRANSPARENTE

VENTOUSE
SUCITON
VENTOSA

2556/009

Pla	⊙ 14 mm	⊙ 4880	€/u
-----	---------	--------	-----

SISTEMA CUT-LINE

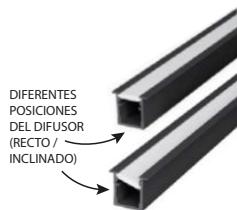

DIFFERENTES POSICIONES DEL DIFUSOR (RECTO / INCLINADO)

PERFIL DE ALUMINIO CON LED INCORPORADO
PROFILÉ EN ALUMINIUM AVEC LED INTÉGRÉE
ALUMINIUM PROFILE WITH BUILT-IN LED
PROFILO IN ALLUMINIO CON LED INTEGRATO

4000K 6025/301
5000K 6026/301

SET CONECTOR + TAPA
CABLE 40CM 6030/041

GRAPAS 6031/041

PL. M	ALU. M	ALU. M	ALL. NAT.
			01

Pla	⊔ 3 m	€/u
	⊙ CRI>90	⊖ 9,6W 24V

SISTEMA DE PERFIL DE ALUMINIO CON LED INCORPORADO SE PUEDE ENCASTRAR A LA MADERA O AUTOADHESIVAR

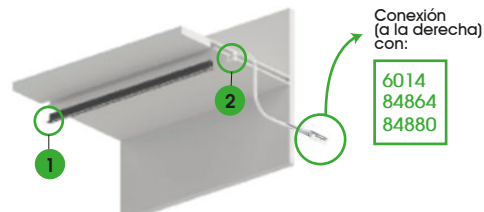

Conexión (a la derecha) con:

6014
84864
84880

CORTE TOTALMENTE LIBRE, SIN LIMITES DE MEDIDAS

SE CORTA TODA LA ESTRUCTURA Y EL LED A LA MEDIDA DESEADA Y SE REMATA CON LOS TAPONES FINALES POR AMBOS LADOS





BARRA ACCES. FR.

5901/1..

KIT compuesto por:
- Cartelas Ref.5380
-Tubo rectangular
Ref.4900/12B
-LED de 1m

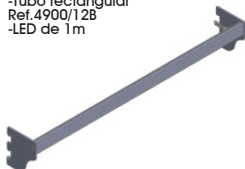

BARRA DE CUELQUE PARA
ACCESORIOS FRONTALES
CON ILUMINACIÓN Y
PROTECCIÓN PLÁSTICA
SUPERIOR

5901/1..

MONTADO

Barre de suspension pour
accessoires avant avec
éclairage
Hanger bar for front
accessories with lighting
Barra appendibili per
accessori frontali con
illuminazione

1M máx.
7
cm

PL. M	BLANCO	NEGRO	COLOR
ALU. M	BLANC	NOR	COULEUR
ALU. M	WHITE	BLACK	COLOR
ALL. NAT	BANCO	NERO	COLORE
01	0B	0N	0P

€/u

ACCESORIO CONECTOR

KIT LUZ
CENTAL



Cartela
X1



Conector
X1

KIT ACCESORIO CONECTOR DE
PLÁSTICO PARA ILUMINACIÓN
CENTAL
KIT D'ACCESSOIRES DE
CONNECTEUR EN PLASTIQUE
POUR ÉCLAIRAGE AÉRIEN
PLASTIC CONNECTOR
ACCESSORY KIT FOR OVERHEAD
LIGHTING
KIT ACCESSORI CONNETTORE IN
PLASTICA PER ILLUMINAZIONE
AMBIENTALE

5330/010

COLOR
COULEUR
COLOR
COLORE

0P

Pla	€/u
-----	-----

o

Ejemplo de aplicación:

La pieza actua como soporte del
conector el qual da conexión a la luz
superior, permitiendo iluminar los plafones
superiores de la estructura.

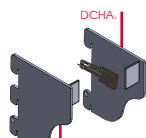
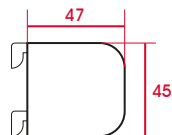

Kit de 2
cartelas:
DERECHA (con
conector) +
IZQUIERDA

KIT CARTELAS BARRA
ACCESORIOS
KIT SUPPORT BARRÉ
ACCESSOIRES
KIT BRACKET FOR
ACCESSORIES ROD
KIT MENSOLA TUBO
PORTA-ACCESSORI

5380/0..

Fe	4900	€/u
71 mm medida útil		

o o o

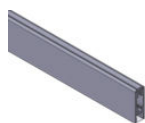

LED no incluido.
LED
recomendado de
5mm de ancho.
Incluye perfil de
plastico superior y
difusor interior.

TUBO RECTANGULAR PARA
ILUMINACIÓN 30X10MM CON
PLETINA DE REFUERZO
KIT TUBE RECTANGULAIRE POUR
ECLAIRAGE 30X10MM AVEC
PLAQUE DE RENFORT
KIT RECTANGULAR TUBE FOR
LIGHTING 30X10MM WITH
REINFORCING PLATE
KIT TUBO RETTANGOLARE PER
ILLUMINAZIONE 30X10MM CON
PIASTRA DI RINFORZO

4900/12.

CON ALMA DE
ACERO INOX

CARGA LIGERA

Al	1 m	€/u
30x10	4901	

o o o



182 diodos (20λ);
cortable cada
3,8 cm
Cable, fil. wire,
cavo: 45 mm
Ancho 5mm

flexible y con
cinta adhesiva
fleible and
self-adhesive

LED CON
MINI-CONECTOR 24V
BANDE LED AVEC
MINI-PLUG 24V
LED STRIP WITH
MINI-PLUG 24V
STRACIA LED CON
MINI-PLUG 24V
4901/109

Pla	1 m	5000 K	€/u
CRI>90		15,3W 24V	

PLÁSTICO
PLASTIQUE
PLASTIC
PLASTICA

09

o

EJEMPLO DE APLICACIÓN

Barras de
accesorios con
cuelgue frontal.



NO APTO PARA
PERROQUET
SOLO GANCHO

CARGA LIGERA

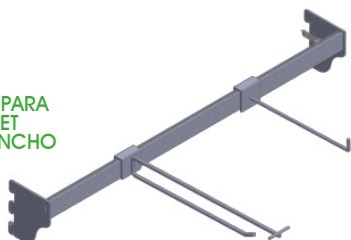



SISTEMA CUT-LINE

PERFIL DE ALUMINIO CON LED INCORPORADO
PROFILÉ EN ALUMINIUM AVEC LED INTÉGRÉE
ALUMINIUM PROFILE WITH BUILT-IN LED
PROFILO IN ALLUMINIO CON LED INTEGRATO

PL	M	ALU. M	ALU. M	ALL. NAT
01				
Pla	3 m	€/u		
	CRI > 90	9,6W/24V		

6025/301 4000K
6026/301 5000K

SET CONECTOR + TAPA
CABLE 40CM
6030/041

GRAPAS
6031/041

SISTEMA DE PERFIL DE ALUMINIO CON LED INCORPORADO

SE PUEDE ENCASTRAR A LA MADERA O AUTOADHESIVAR

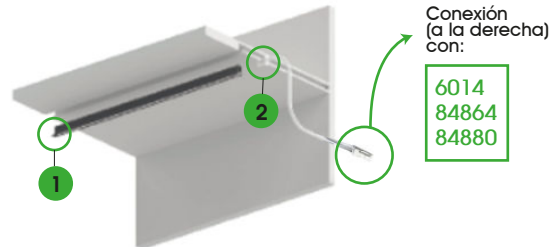

Conexión (a la derecha) con:

- 6014
- 84864
- 84880

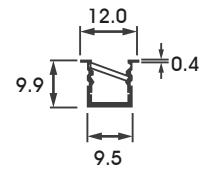
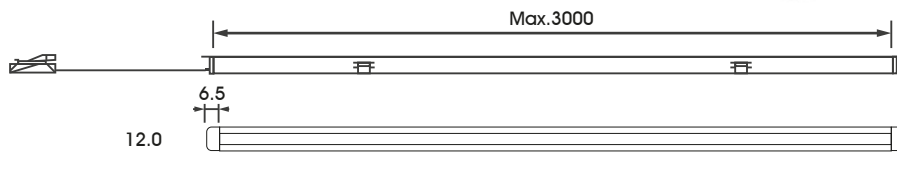

CORTE TOTALMENTE LIBRE, SIN LIMITES DE MEDIDAS

SE CORTA TODA LA ESTRUCTURA Y EL LED A LA MEDIDA DESEADA Y SE REMATA CON LOS TAPONES FINALES POR AMBOS LADOS

DISTINTAS MANERAS DE POSICIONAR EL LED SEGÚN NECESIDAD DE DIRECCIONAR LA LUZ

PERFILES CON ILUMINACIÓN

PERFIL ALUMINIO
PROFIL EN ALUMINIUM
ALUMINIUM PROFILE
PROFILO DI ALUMINIO

4744/1..

PERFIL ALUMINIO
PROFIL EN ALUMINIUM
ALUMINIUM PROFILE
PROFILO DI ALUMINIO

4748/1..

PERFIL ALUMINIO
PROFIL LAME D'ALUMINIUM
ALUMINIUM SLATWALL
PROFILO DOGATO
ALLUMINIO

*362/1...

PERFIL ALUMINIO
PROFIL EN ALUMINIUM
ALUMINIUM PROFILE
PROFILO DI ALUMINIO

4892/1..

LED no incluido. LED recomendado de 5mm de ancho. Incluye perfil de plástico superior y difusor inferior.

TUBO RECTANGULAR PARA ILUMINACIÓN
30X10MM CON PLETINA DE REFUERZO
KIT TUBE RECTANGULAIRE POUR ECLAIRAGE
30X10MM AVEC PLAQUE DE RENFORT
KIT RECTANGULAR TUBE FOR LIGHTING
30X10MM WITH REINFORCING PLATE
KIT TUBO RETTANGOLARE PER ILLUMINAZIONE
30X10MM CON PIASTRA DI RINFORZO

4900/12.

CON ALMA DE ACERO INOX

CARGA LIGERA
max. 30KG

PL	M	BLANCO	NEGRO	COLOR
ALU. M		BLANC	NOIR	COULEUR
ALU. M		WHITE	BLACK	COLOR
ALL. NAT		BIANCO	NERO	COLORE
01	0B	0N	0P	
Al	5 m	30x30	€/m	
	84602			
Al	6 m	21,5x20	€/m	
	4893			
Al	5 m	6-8mm	€/m	
	361/109			
Al	5 m	32x11,2	€/m	
	4893 - 4894			
Al	30x10			
	4901/109			
	1 m	€/u		

LEDs

LED CON MINI-CONECTOR 24V
BANDE LED AVEC MINI-PLUG 24V
LED STRIP WITH MINI-PLUG 24V
STRACIA LED CON MINI-PLUG 24V

182 diodos (20λ); cortable cada 3.8 cm
 Cable, fil, wire, cavo: 45 mm
 Ancho 5mm
 flexible y con cinta adhesiva
 flexible and self-adhesive

4901/109

LED CON MINI-CONECTOR 24V
BANDE LED AVEC MINI-PLUG 24V
LED STRIP WITH MINI-PLUG 24V
STRACIA LED CON MINI-PLUG 24V

182 diodos (20λ); cortable cada 3.8 cm
 Cable, fil, wire, cavo: 40cm
 Ancho 5mm
 flexible y con cinta adhesiva
 flexible and self-adhesive

4910/109

LED CON MINI-CONECTOR 24V
BANDE LED AVEC MINI-PLUG 24V
LED STRIP WITH MINI-PLUG 24V
STRACIA LED CON MINI-PLUG 24V

126 diodos (20λ); cortable cada 5.5 cm
 Cable, fil, wire, cavo: 40cm
 Ancho 8 mm
 flexible y con cinta adhesiva
 flexible and self-adhesive

4890/009

LED CON MINI-CONECTOR 24V
BANDE LED AVEC MINI-PLUG 24V
LED STRIP WITH MINI-PLUG 24V
STRACIA LED CON MINI-PLUG 24V

126 diodos (20λ); cortable cada 5.5 cm
 Cable, fil, wire, cavo: 26cm
 Ancho 8mm
 flexible y con cinta adhesiva
 flexible and self-adhesive

4890/109



EASY LIGHT - MAGNETIC LED

EASY LIGHT - SISTEMA IMANTADO



Los productos de la familia **EASY LIGHT** tienen **certificado** de conformidad a la directiva comunitaria **2014/30/EU** y al **RoHS 2011/65/EU** y actualizaciones posteriores.

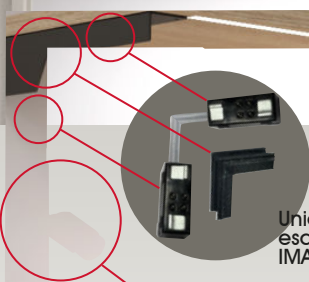

Uniones para esquinas también IMANTADAS

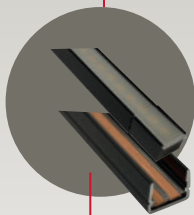

Diferentes tipos de accesorios IMANTADOS

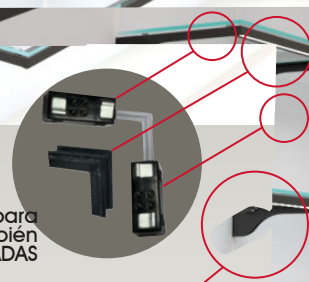

Uniones para esquinas también IMANTADAS



Posibilidad de ENCASTRAR.

* El cable de corriente pasa por el interior y sale por la parte inferior de la pieza

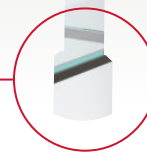



SISTEMA DE ILUMINACIÓN

- Sistema de riel de suministro eléctrico para módulos de iluminación combinables con imán, perfecto para estantes, gabinetes, escaparates, etc.
- Múltiples métodos y ángulos de instalación (adhesivado, atornillado, encastrado, etc).
- Tamaño pequeño, acabado integrado y apto para espacios estrechos.
- Fácil instalación.
- Sistema de vía de alimentación eléctrica fácilmente conectable. Con diferentes módulos de iluminación combinables.

CARRIL

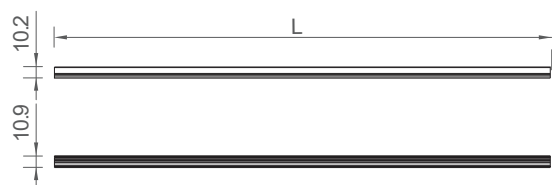

SPOT LIGHT

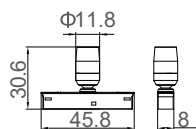

STRIP LIGHT

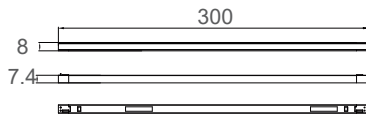

- Instalación a 45° - invisible (Método de instalación: Clips o cinta adhesiva)
- Instalación a 90° - invisible (Método de instalación: Clips)



Los dos métodos anteriores se ajustan a la vitrina y al escaparate

- Instalación montada en superficie (Método de instalación: Clips o cinta adhesiva)



INTENSIDAD LUMINOSA

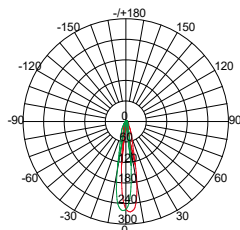

LOS CABLES CONECTORES DEBEN MANTENER TODOS LA MISMA DIRECCIÓN PARA MANTENER LA POLARIDAD



Los productos de la familia **EASY LIGHT** tienen **certificado** de conformidad a la directiva comunitaria **2014/30/EU** y al **RoHS 2011/65/EU** y actualizaciones posteriores.

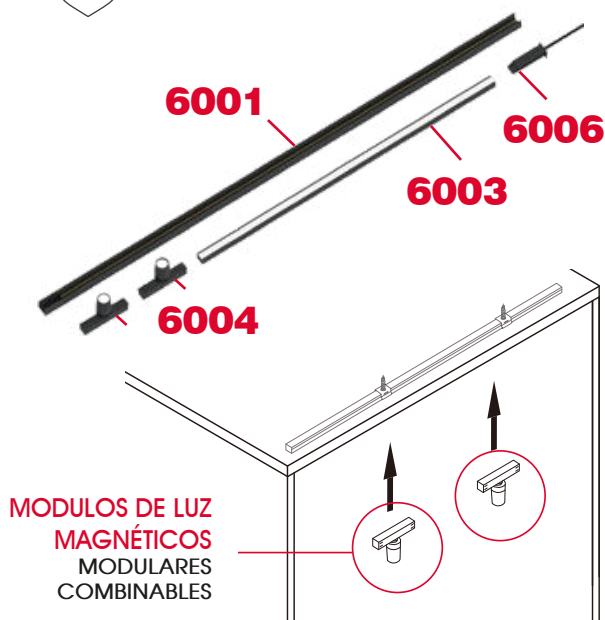

MODULOS DE LUZ MAGNÉTICOS MODULARES COMBINABLES

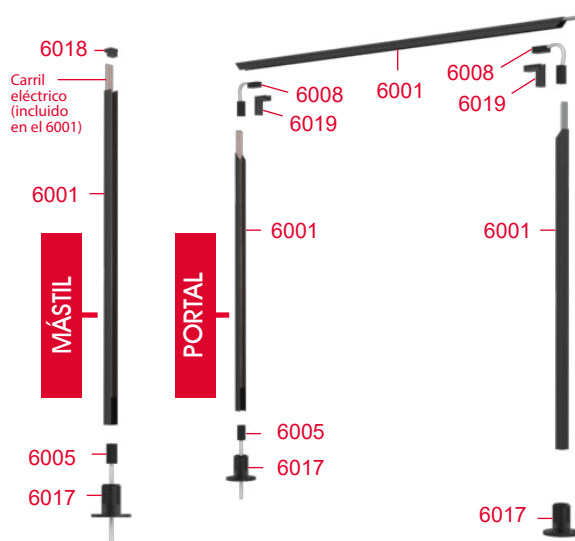

ESPECIFICACIONES

	CARRIL	LUZ FOCAL	LUZ LINEAR
TAMAÑO:	Lx10.2x10.9mm (Longitud opcional)	30.6x11.8mm	300x8x8.5mm
ENTRADA NOMINAL:	/	24V DC	24V DC
FUERZA:	/	0.6W	3.5W
FLUJO LUMINOSO (TYP@4000K):	/	38lm	266lm
RA:	/	90	90
EFICIENCIA:	/	67lm/W	75lm/W
IP:	20	20	20
COLOR:	Negro	Negro	Negro
CCT:	/	4000K	4000K
INSTALACIÓN:	Clips / Cinta adh.	Magnética	Magnética



COMPONENTES SISTEMA MAGNETIC LED

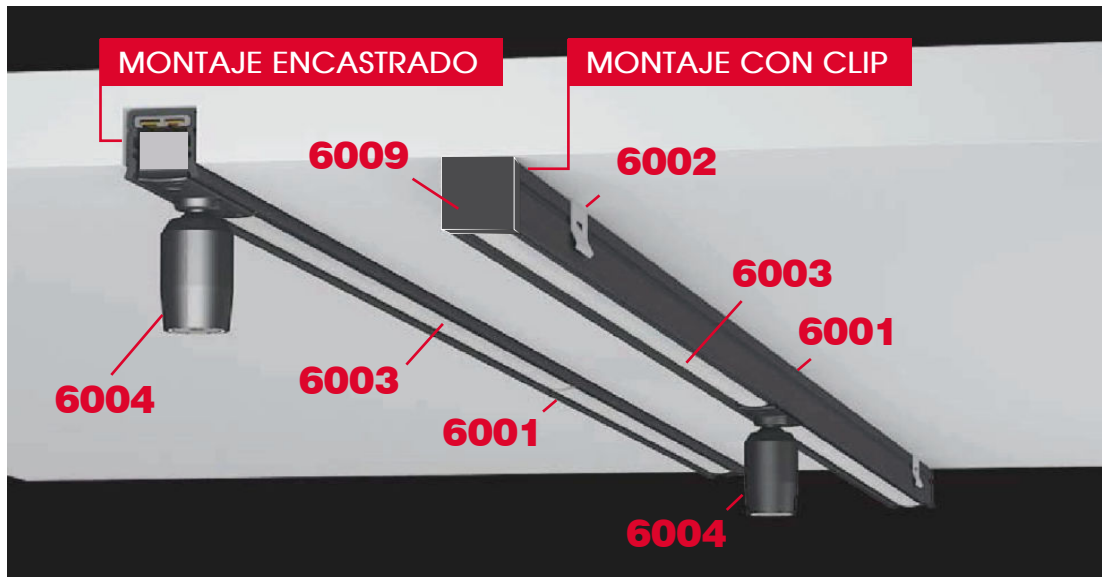

	INOX	SAT	NEGRO			
<p>MAGNÉTICO</p>	CARRIL ELECTRIFICADO MAGNÉTICO RAIL ÉLECTRIFIÉ MAGNÉTIQUE MAGNETIC ELECTRIFIED RAIL BINARIO ELETRIFICATO MAGNETICO		28 ON	2 m	€/u	○
	6001/20N					
<p>MAGNÉTICO</p>	CLIP PARA FIJACIÓN CLIP DE FIXATION FIXING CLIP CLIP DI FISSAGGIO		6001-6012	€/u		○
	6002/028					
<p>MAGNÉTICO</p>	LED ILUMINACIÓN LINEAR ÉCLAIRAGE LINÉAIRE À DEL LED LINEAR LIGHTING ILLUMINAZIONE LINEARE A LED		4000 K 3,5 W 24V	30 cm	€/u	○
	6003/00N					
<p>MAGNÉTICO</p>	MÓDULO DE ILUMINACIÓN FOCAL MODULE PLEINS FEUX SPOTLIGHT MODULE MODULO FARETTO		4000 K 0,8 W 24V	30 cm	€/u	○
	6004/00N					
<p>Posibilidad de encastrar (taladro: Ø20mm)</p>	BASE (FORMATO VERTICAL) BASE (FORMAT VERTICAL) BASE (VERTICAL FORMAT) BASE (FORMATO VERTICALE)		Placa	Ø19,5mm	€/u	○
	6017/00N					
	TAPA DE CARRIL (6001) COUVERCLE DE RAIL (6001) RAIL COVER (6001) COPRIBINARIO (6001)		Placa		€/u	○
	6018/00N					
	UNIÓN 90° UNION 90° 90° UNION UNIONE 90°		Placa		€/u	○
	6019/00N					
<p>MAGNÉTICO</p>	CONECTOR MAGNÉTICO CARRIL-DRIVER CONNECTEUR MAGNÉTIQUE RAIL-DRIVER MAGNETIC CONNECTOR RAIL-DRIVER CONNETTORE MAGNETICO RAIL-DRIVER		ON	150cm	€/u	○
	6005/00N					
<p>MAGNÉTICO</p>	CONECTOR MAGNÉTICO CARRIL-CONECTOR CARTELAS KADI CONNECTEUR MAGNÉTIQUE RAIL-CONNECTEUR SUPPORT KADI MAGNETIC CONNECTOR RAIL-CONNECTOR KADI BRACKET CONNETTORE MAGNETICO BINARIO - CONNETTORE MENSOLA KADI		Placa	40cm	€/u	○
	6006/00N					
<p>MAGNÉTICO</p>	CONECTOR MAGNÉTICO CARRIL-LED UNIVERSAL CONNECTEUR MAGNÉTIQUE RAIL-LED UNIVERSAL MAGNETIC CONNECTOR RAIL-UNIVERSAL LED CONNETTORE MAGNETICO BINARIO-UNIVERSALE LED		Placa	40cm	€/u	○
	6007/00N					
<p>MAGNÉTICO</p>	CONECTOR MAGNÉTICO CARRIL-CARRIL CONNECTEUR MAGNÉTIQUE RAIL-RAIL MAGNETIC CONNECTOR RAIL-RAIL CONNETTORE MAGNETICO BINARIO - BINARIO		Placa	4 cm	€/u	○
	6008/00N					
<p>6 SALIDAS</p>	DRIVER 100W, 24V / CONECTOR HEMBRA CONDUCTEUR 100W, 24V / CONNECTEUR FEMELLE DRIVER 100W, 24V / FEMALE CONNECTOR DRIVER 100W, 24V / CONNETTORE FEMMINA		Placa	15cm	€/u	○
	6010/009					



EASY LIGHT - EASY

- Sistema de riel de suministro eléctrico para módulos de iluminación combinables con imán, perfecto para estantes, gabinetes, escaparates, etc.
- Múltiples métodos y ángulos de instalación (adhesivado, atornillado, encastrado, etc).
- Tamaño pequeño, acabado integrado y apto para espacios estrechos.
- Fácil instalación.
- Sistema de vía de alimentación eléctrica fácilmente conectable. Con diferentes módulos de iluminación combinables.

CARRIL

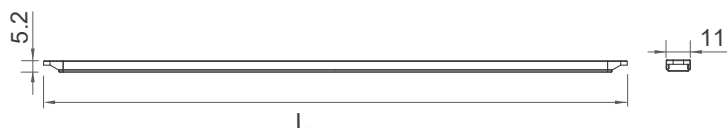

CABLE

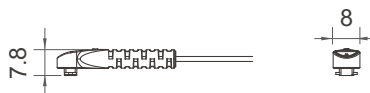

LONGITUD:	Lx11x5.2mm
CABLE DE ENTRADA:	22# AWG UL 2468 CABLE
INPUT:	8A
CABLE DE SALIDA:	22# AWG UL 2468 CABLE
OUTPUT:	3A
MAX. LONGITUD:	2500mm
INSTALACIÓN:	Montaje Magnético, Montaje con Tornillos, Adhesivado
COLOR:	Blanco / Negro

LOS CABLES CONECTORES DEBEN MANTENER TODOS LA MISMA DIRECCIÓN PARA MANTENER LA POLARIDAD



Los productos de la familia **EASY LIGHT** tienen **certificado** de conformidad a la directiva comunitaria **2014/30/EU** y al **RoHS 2011/65/EU** y actualizaciones posteriores.

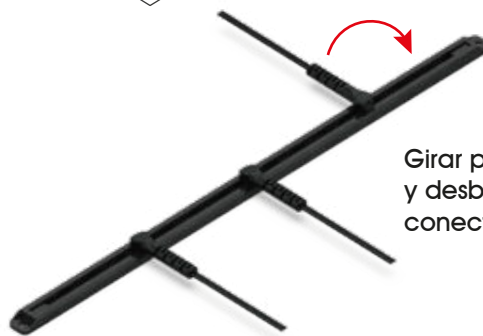

Girar para bloquear y desbloquear el conector.

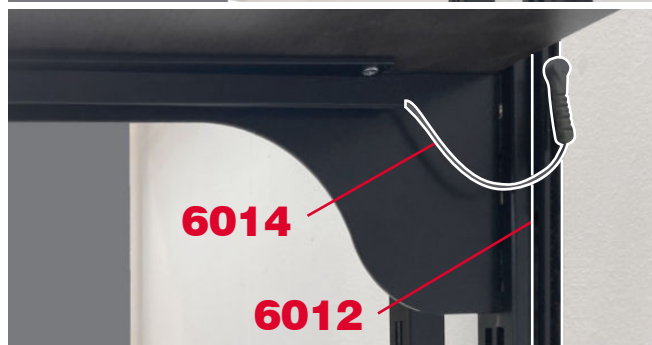
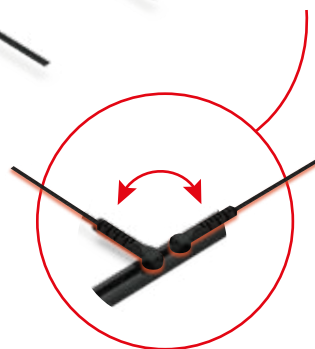



COMPONENTES SISTEMA EASY



CARRIL ELECTRIFICADO
RAIL ELECTRIFIÉ
ELECTRIFIED RAIL
BINARIO ELETRIFICATO
6012/25.



(x2 u.)

TAPÓN FINAL
BOUCHON D'EXTRÉMITÉ
END PLUG
TAPPO FINE
6011/0..



MAGNÉTICO

CINTA MAGNÉTICA ADHESIVA
RUBAN MAGNÉTIQUE ADHÉSIF
ADHESIVE MAGNETIC TAPE
NASTRO MAGNETICO ADESIVO
6012/000 50M
6012/100 1M



CINTA ADHESIVA DOBLE CARA
RUBAN MAGNÉTIQUE ADHÉSIF
ADHESIVE MAGNETIC TAPE
NASTRO MAGNETICO ADESIVO
6012/009 66M



126 diodos (20λ); cortable
cada 5,5 cm
Cable: fil. wire, cavo: 40cm
Ancho 8 mm
flexible y con cinta adhesiva
flexible and self-adhesive

LED CON MINI-CONECTOR 24V
BANDE LED AVEC MINI-PLUG 24V
LED STRIP WITH MINI-PLUG 24V
STRACIA LED CON MINI-PLUG
24V
4890/009



CONECTOR DIVER 6 VÍAS 20CM
CONNECTEUR PLONGEUR 6
VOIES 20CM
6-WAY DIVER CONNECTOR
20CM
CONNETTORE SUBACQUEO A 6
VIE 20 CM
6021/009

BLANCO BLANC WHITE BIANCO	NEGRO NOR. BLACK NERO
OB	ON

2,5 m	24V	€/u
-------	-----	-----

o o

€/u

o o

PLÁSTICO PLASTIQUE PLASTIC PLASTICA
09

€/u	o
€/m	o

€/u

Pla	1 m	5000 K	€/u
-----	-----	--------	-----

CR>90	9,6 W 24V
-------	-----------

o

Pla	3 m	€/u
230 V	2,5 A	

o



CONECTOR CARRIL-DRIVER/
CONECTOR SEGURIDAD ALUSYSTEM
CONNECTEUR RAIL-DRIVER /
CONNECTEUR SÉCURITÉ DU ALUSYSTEM
CONNECTOR RAIL-DRIVER /
CONNECTOR ALUSYSTEM SECURITY
CONNETTORE RAIL-DRIVER /
CONNETTORE LA SICUREZZA ALUSYSTEM
6013/0..



CONECTOR CARRIL-LED / HEMBRA
CONNECTEUR RAIL-LED / FEMELLE
RAIL-LED CONNECTOR / FEMALE
CONNETTORE RAIL-LED / FEMMINA
6014/0..



CABLE CONEXIÓN DRIVER PARA SOLDAR
MODULE PLEINS FEUX
SPOTLIGHT MODULE
MODULO FARETTO
6015/00B



DRIVER 100W, 24V /
CONECTOR HEMBRA
CONDUCTEUR 100W, 24V /
CONNECTEUR FEMELLE
DRIVER 100W, 24V / FEMALE CONNECTOR
DRIVER 100W, 24V / CONNETTORE FEMMINA
6010/009



CABLE ALARGO MACHO-HEMBRA 3M
CÂBLE D'EXTENSION MÂLE-FEMELLE DE 3 M
3M MALE-FEMALE EXTENSION CABLE
CAVO DI PROLUNGA MASCHIO-
FEMMINA 3M
6022/00B

BLANCO BLANC WHITE BIANCO	NEGRO NOR. BLACK NERO
OB	ON

Pla	24V	€/u
1M		

o o

Pla	24V	€/u
10cm		

o o

Pla	1M	€/u
-----	----	-----

o

Pla	24V 100W	€/u
PLÁSTICO PLASTIQUE PLASTIC PLASTICA	09	

o

Pla	€/u
230 V	

3 m	2,5 A
-----	-------

o



SISTEMA ILUMINACIÓN PARA MUEBLES DE MADERA

VARIO

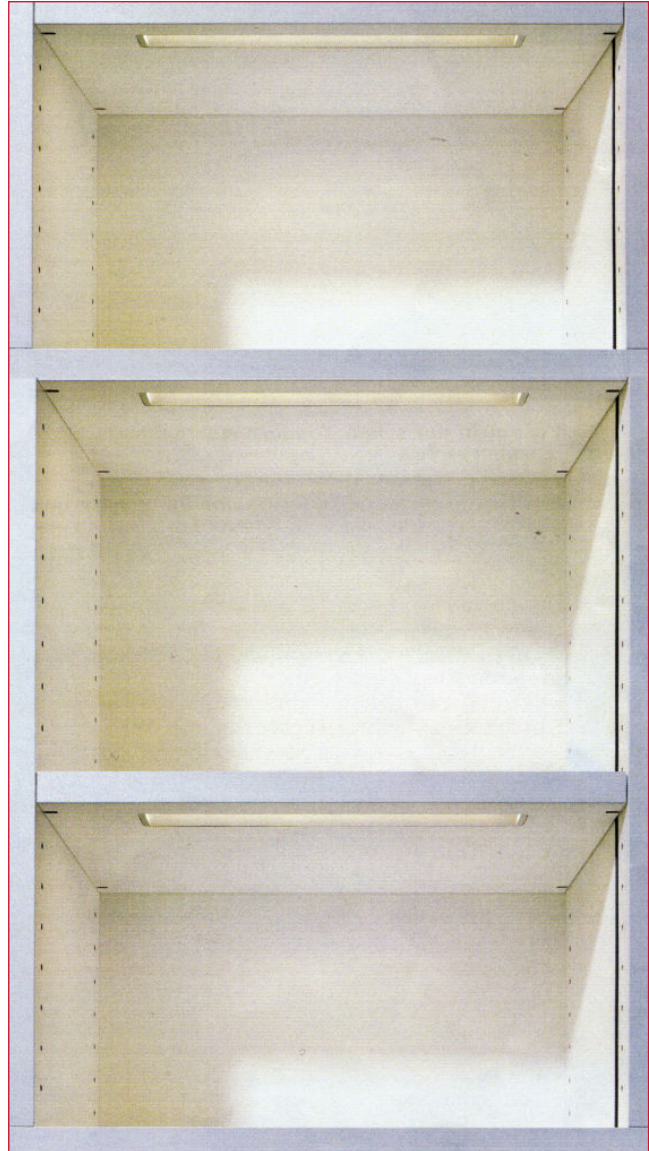

VARIO es una nueva solución de iluminación para la electrificación de estanterías de madera.
- Los estantes pueden colocarse de manera fácil a cualquier altura sin preocuparse de la conexión eléctrica.
- Grosor mínimo estante: 22 mm
- 24 V

VARIO est une nouvelle solution d'éclairage pour l'électrification des étagères en bois.

- Les étagères peuvent être situées facilement quelle hauteur indépendamment de la connexion électrique.

- Épaisseur min. étage: 22 mm
- 24V

VARIO is a new lighting solution for wood shelves electrification.

- Shelves can be placed easily at any height without worrying about the electrical connections.

- Minimum shelf thickness: 22 mm
- 24V

VARIO è una nuova soluzione di illuminazione per l'elettificazione di scaffalature in legno.

- Le mensole possono essere posizionate facilmente a qualsiasi altezza senza preoccuparsi delle connessioni elettriche.

- Spessore min. ripiano: 22 mm
- 24 V



COMPONENTES
SISTEMA VARIO

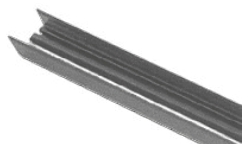

CARRIL ELECTRIFICADO
RAIL D'ALIMENTATION 24V
POWER RAIL 24V
BINARIO ELETRIFICATO 24V
*4805/309

plas	3000 mm
	24V - máx. 6A €/u

09



male
macho

CONECTOR ALIMENTACIÓN
CARRIL - DRIVER
ALIMENTACION DE CONECTOR
RAIL-DRIVER
FEEDER CONNECTOR TRACK - DRIVER
CONNETTORE BINARIO ELETRIFICATO - DRIVER
*4807/049
UNO POR CARRIL

plas	400 mm
	24V - máx. 6A €/u



female
hembra

CONECTOR LED A CARRIL
ELECTRIFICADO
LED CONECTOR A RAIL
D'ALIMENTATION
LED CONNECTOR TO POWER RAIL
CONNETTORE LED A BINARIO ELETRIFICATO
*4806/109
UNO POR ESTANTE

plas	100 mm
	24V - máx. 6A €/u



macho
male



PERFIL ALUMINIO + LED
ALUMINIUM PROFIL + LED
ALUMINIUM PROFILE + LED
ALLUMINIO PROFILO + LED
*4809/089 862 mm

Al	CrI>85
9W - 24V	4000 K €/u



DRIVER + 6 SALIDAS CON
MINI-CONECTORES 24V
DRIVER + DISTRIBUTEURS 6 SORTIES
AVEC MINI-PLUG 24V
DRIVER + DISTRIBUTOR 6 WAYS-BLOCK
WITH MINI-PLUG 24V
DRIVER + DISTRIBUTORE 6 USCITE
CON MINI-PLUG 24V
*4770/009

plas	3 m
	100W - 230V > 24V €/u



female
hembra

COMPRANDO EL SISTEMA COMPLETO DESDE EL
ENCHUFE HASTA EL LED 4809:

- 2 AÑOS DE GARANTIA
- DESCUENTO ADICIONAL DEL 30%

El sistema completo no precisa certificado de instalación de
baja tensión

MONTAJE SISTEMA VARIO

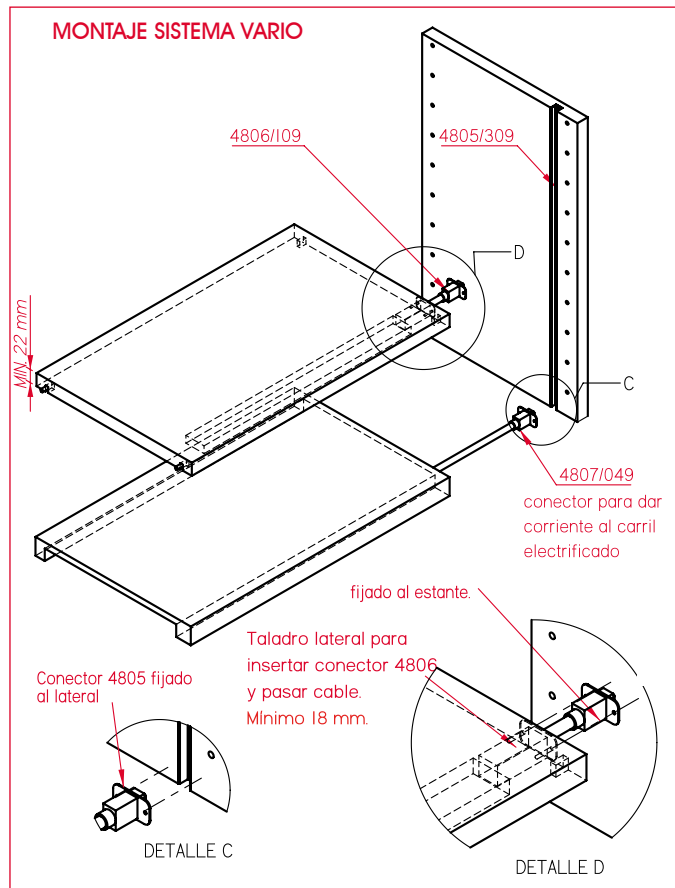

DIMENSIONES REF. 4806 Y 4807

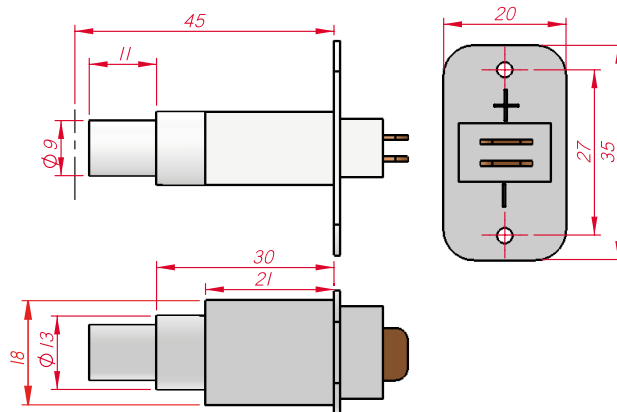

DIMENSIONES REF. 4809

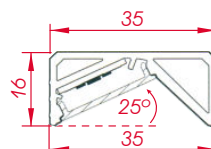

DIMENSIONES REF. 4805

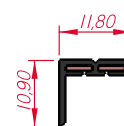



instal.

KADÍ

SISTEMAS SIN ILUMINACIÓN

KADÍ CREMALLERAS

KADÍ OMEGA
KADÍ ALA
KADÍ CLASSIC
KADÍ HIERRO EMPOTRABLE
KADÍ EMPOTRABLE ALUM.
KADÍ DUO

KADÍ CREMALLER. COMPONENTES

KADÍ EMPOTRABLE ALUM.
KADÍ COLUMNA
KADÍ VÉRTICE
BOTONES PLÁST. PANELAD.
KADÍ OMEGA
KADÍ ALA
KADÍ DUO
KADÍ HIERRO EMPOTRABLE

KADÍ TUBULAR

KADÍ CARTELAS

CAPACIDAD DE CARGA

CARTELAS EMPOTRABLE
CARTELAS "SILUETTE"
CARTELAS SILUET. INCLIN.
CABALL. ESTANTE CARTEL.
CARTELAS "TIBURÓN"
CARTELAS PASANTES
CARTEL. PASANT. ACCES.
ACCESORIOS TUBO OBAL.
PERROQUETES
SIST. CUELGUE DE MUEBLES

PERFIL PARA SIST. KADÍ Y LAMAS

KADÍ COLUMNAS

VERONA
BILBO
MILÁN
ACCESORIOS - COMPLEM.

KADÍ PHARMA DUO

SISTEMA
CORTE DE LA MADERA
COLUMNAS TROQUELAD.
COMPONENTES
PHARMA
PHARMA DUO

MULTILAMA
PHARMA + MULTILAMA

SEPARADORES Y PORTA PRECIOS

SEPARADOR CON
DISPENSADOR DE PRODUCTO
PORTA PRECIOS PARA
VIDRIO Y MADERA

KADÍ PRIMO 25X25

NUDOS A PRESIÓN
NUDOS BRIDA
TAPONES
TUBO 25X25
ACCESORIOS

EJEMPLOS DE MONTAJE

KADÍ CREMALLERAS

MEDIDAS CREMALLERAS Y MECANIZACIONES

4614

4615

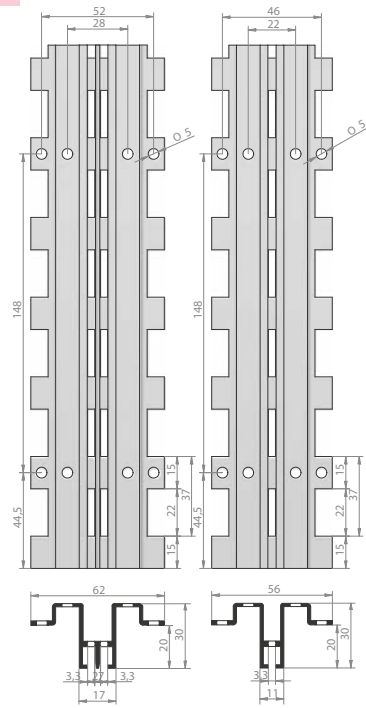

KADÍ DUO

4566

4574

4576

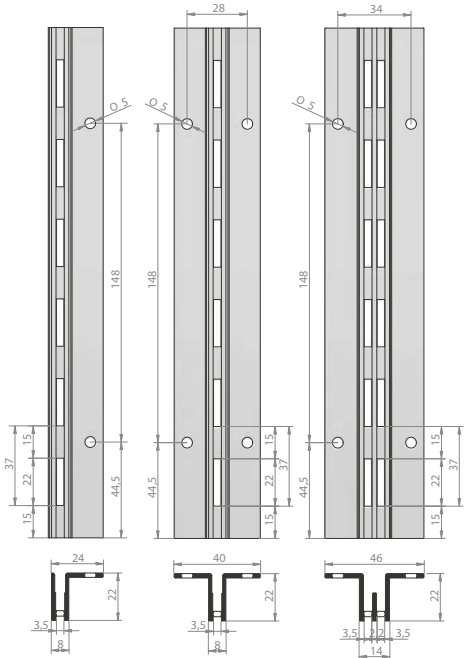

KADÍ OMEGA

4608

4609

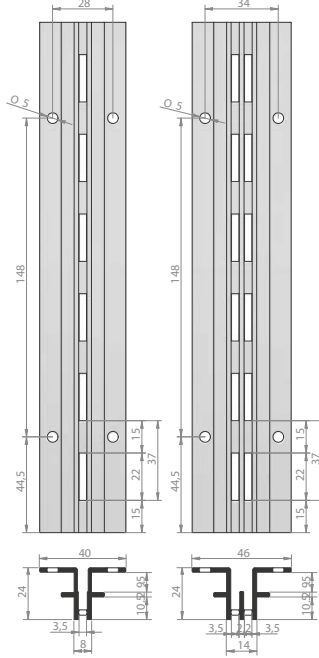

KADÍ ALA

4610

4605

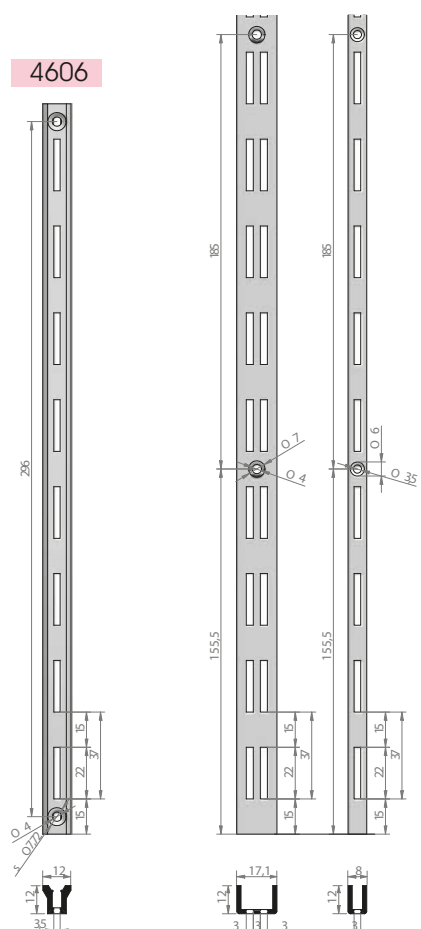

4606

CREMALLERA EMPOTRABLE FRONTALMENTE

4567

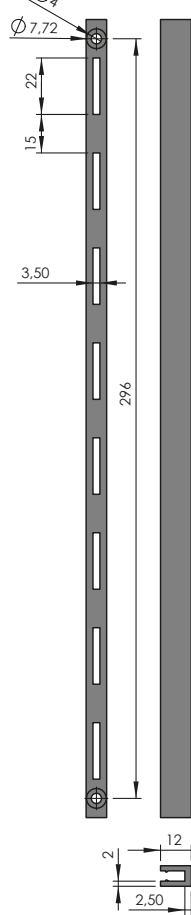

KADÍ EMPOTRABLE ALUMINIO

4600

4601

4602

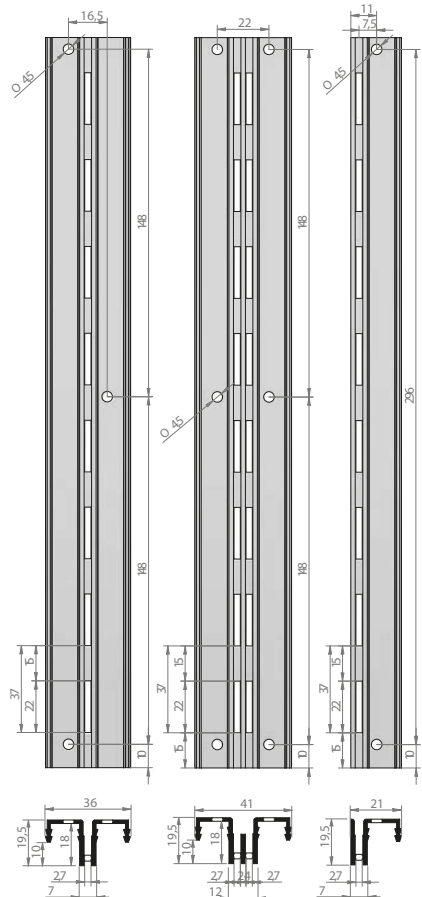

KADÍ CLASSIC

KADÍ COLUMN

KADÍ EMPOTRABLE HIERRO

KADÍ OMEGA

- 1** **CREMALLERAS FIJADAS A PANEL**
crémallères fixées à le panneau
racks fixed to the panel
cremagliere fissate al pannello

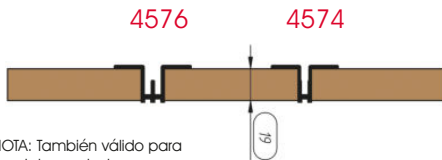
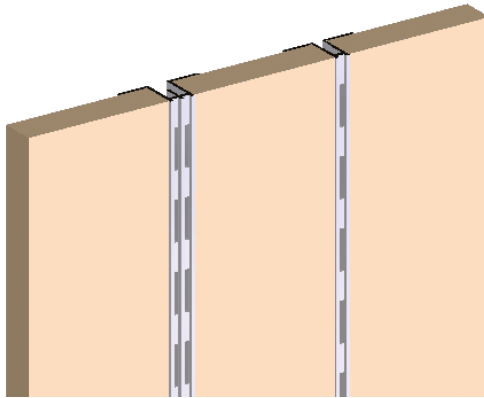

NOTA: También válido para montaje con botones 4780, 4781, 4782.

- 2** **CREMALLERAS EMPOTRADAS CON REMATES 4575 Y 4577**
crémallères insérées avec cabochones 4575 et 4577
racks inserted with end-caps 4575 and 4577
cremagliere inserite da dietro con copritesta 4575 e 4577

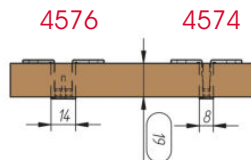
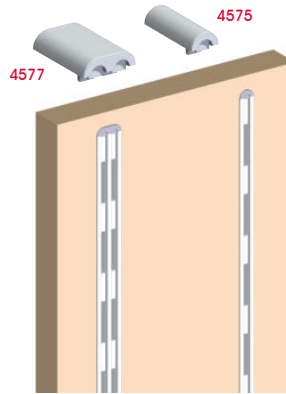

- 3** **CREMALLERAS FIJADAS DIRECTAMENTE A PARED**
crémallères fixées directement au mur
racks fixed directly to the wall
cremagliere fissate direttamente a parete

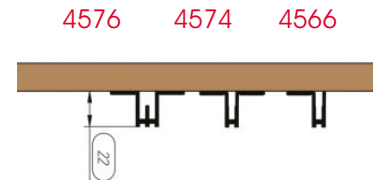
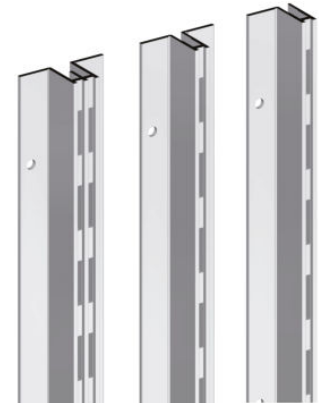

KADÍ ALA

- 1** **ENSAMBLE MACHIHUEMBRADO**
assemblage rainure-langue
tongue-and-groove joint
unione a incastro

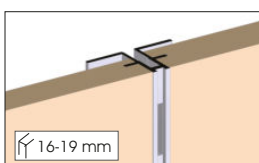
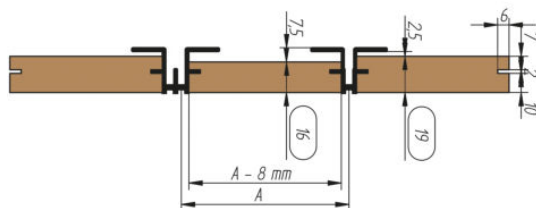
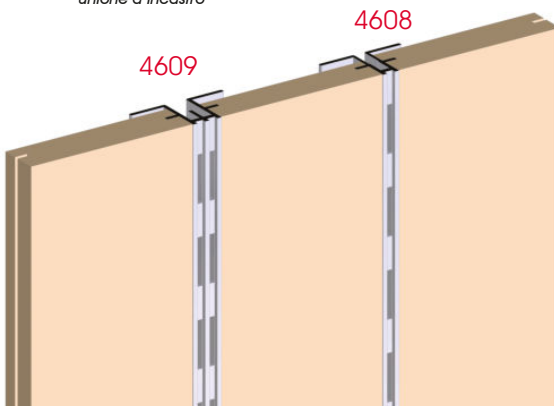

ENSAMBLE CON MADERA DE 16MM O 19MM
assembler avec du bois de 16 mm ou 19 mm
assemble with 16mm or 19mm
assemblare con legno 16mm o 19mm

- 2** **BOTONES 4780, 4781 Y 4782**
crochetes de maintien 4780, 4781 et 4782
panel hooks 4780, 4781 and 4782
fermapannelli 4780, 4781 e 4782

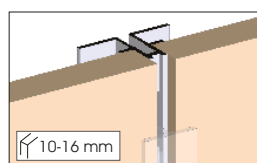
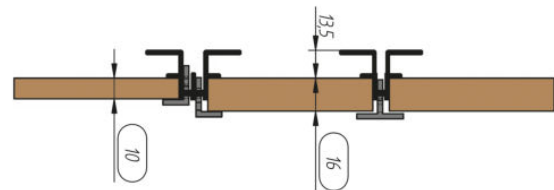
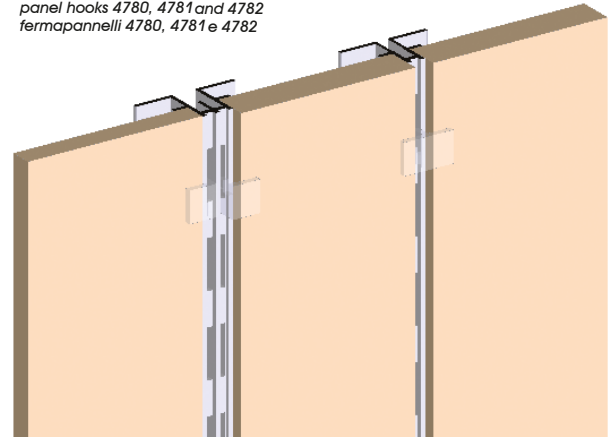

ENSAMBLE CON MADERA DE 10MM O 16MM
assembler avec du bois de 10 mm ou 16 mm
assemble with 10mm or 16mm
assemblare con legno 10mm o 16mm

KADÍ CLASSIC

PATENTADO - BREVETÉ - PATENTED - BREVETTATO

EJEMPLOS DE PANELADO CON LAS GUÍAS 4600, 4601 Y 4602

Examples of paneling with racks 4600, 4601 and 4602
Exemples de panneaux avec des crémaillères 4600, 4601 et 4602
Esempi di montaggio dei pannelli con i profili cremagliera 4600, 4601 e 4602

1 CON "GRAPA CLIP" 4607
avec "GRAPA CLIP" 4607
with "GRAPA CLIP" 4607
con "GRAPA CLIP" 4607

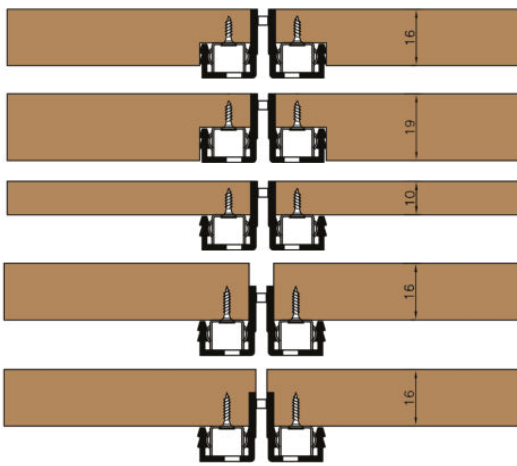

3 EMPOTRADO SIN GRAPA
encastré sans clip
recessed without clip
incasso senza clip



2 CON BOTONES 4780 - 4781 - 4782
avec boutons 4780 - 4781 - 4782
with buttons 4780 - 4781 - 4782
con bottoni 4780 - 4781 - 4782

4780



4781

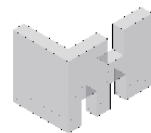

4782

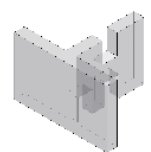

GUÍA VISTA

- con cremalleras 4600, 4601 y 4602
- panel de 10 mm sin rebajar

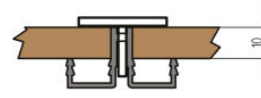

GUÍA OCULTA (6 mm)

- con cremalleras 4600, 4601 y 4602
- con panel de 16 mm sin rebajar

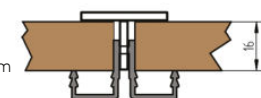

La serie **Classic** y el **casquillo 4699 no admiten** cartelas con los **ganchos del talón pintados**; el troquel tiene una anchura de 2,7 mm y la cartela pintada un espesor de casi 3 mm. **Alu System solo tiene stock de cartelas con el talón sin pintar.** La parte no pintada nunca queda visible desde el exterior. En caso de precisar los talones pintados consultar con departamento comercial.

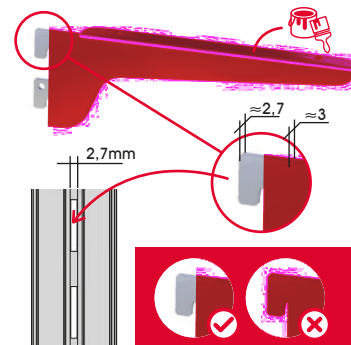

Puede tener algún tipo de oxidación. AluSystem no se hará cargo del posible deterioro.

KADÍ HIERRO EMPOTRABLES

1 ENSAMBLE
assemblage rainure-langette
tongue-and-groove joint
unione a incastro

SE ACONSEJAN TORNILLOS AVELLANADOS CON CABEZA PLANA

Ø 5,5 mm (ej. DIN7997)

Sont recommandés vis à tête fraisée avec tête plate Ø 5,5 mm (ej. DIN7997)

We recommende countersunk screws with flat head Ø 5,5 mm (ej. DIN7997)

Si consigilano viti svasate con testa plana Ø 5,5 mm (ej. DIN7997)

4605 Y 4610
COMPATIBLES CON ACCESORIOS SISTEMA KADÍ
COMPATIBLE AVEC ACCESSOIRES SYSTEME KADÍ
COMPATIBLE WITH KADÍ SYSTEM FITTINGS
COMPATIBLE CON ACCESSORI SISTEMA KADÍ

Disponibile también
en aluminio
REF 4567

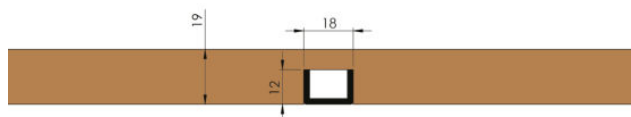
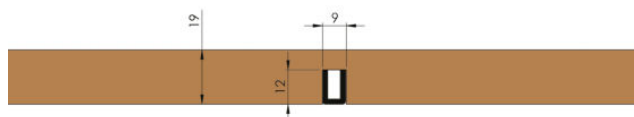
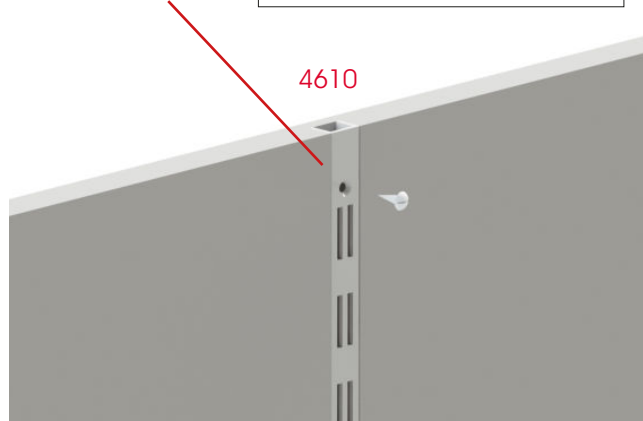
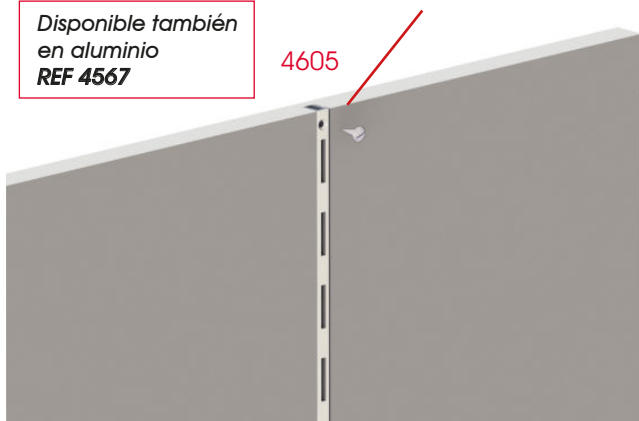

KADÍ DUO

KADÍ DUO 4615 Y KADÍ DOBLE DUO 4614 EMPOTRADAS EN PANEL

RACKS DUO 4615 AND DOBLE DUO 4614 EMBEDDED IN THE PANEL
CRÉMAILLÈRES DUO 4615 AND DOBLE DUO 4614 INTÉGRÉS DANS LE PANNEAU
PROFILI CREMAGLIERA DUO 4615 E DOBLE DUO 4614 INSERITI NEL PANNELLO

4615 KADÍ DUO

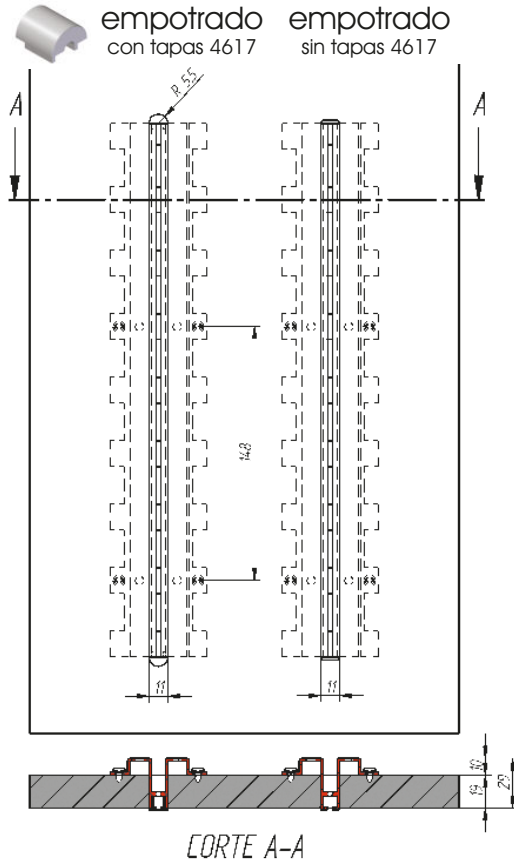
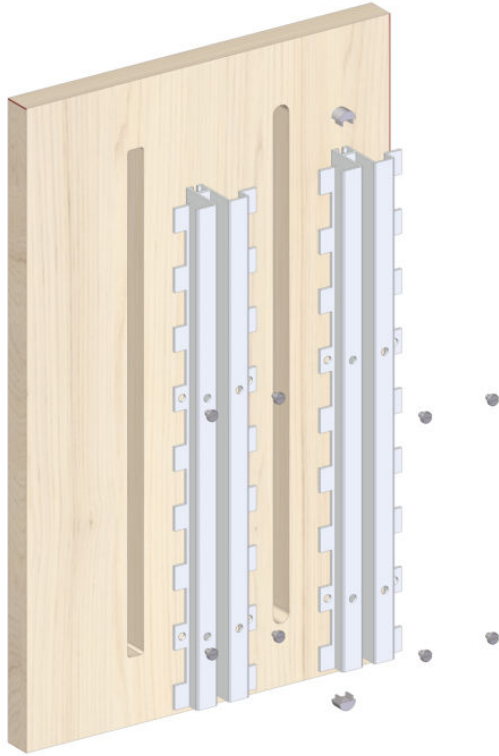

4614 KADÍ DOBLE DUO

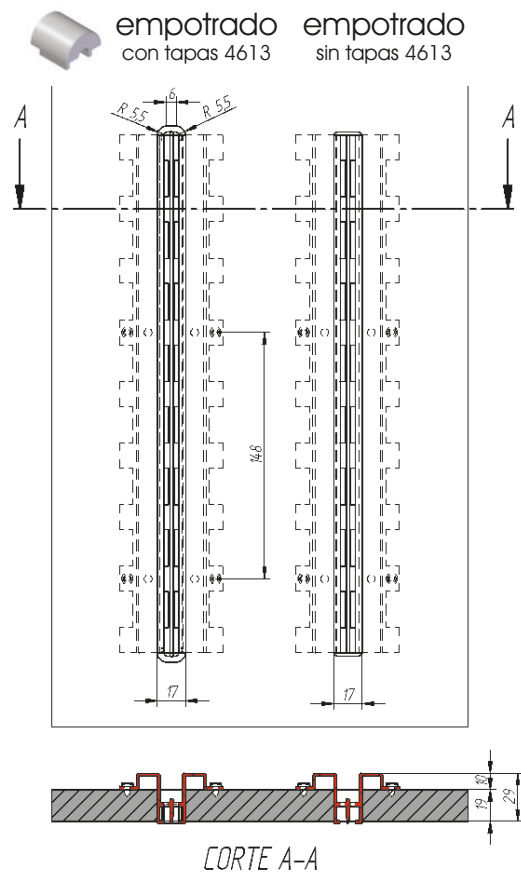

KADÍ DUO 4615 Y KADÍ DOBLE DUO 4614 PANELES COLGADOS A LAS CREMALLERAS

RACKS **DUO 4615** AND **DOBLE DUO 4614** PANEL HUNG TO THE RACK
CRÉMAILLÈRES **DUO 4615** AND **DOBLE DUO 4614** PANNEAUX ACCROCHÉ A LE CRÉMAILLÈRE
PROFILI CREMAGLIERA **DUO 4615** E **DOBLE DUO 4614** PANNELLO APPESO AL PROFILO



ref. 4614 - DOBLE DUO

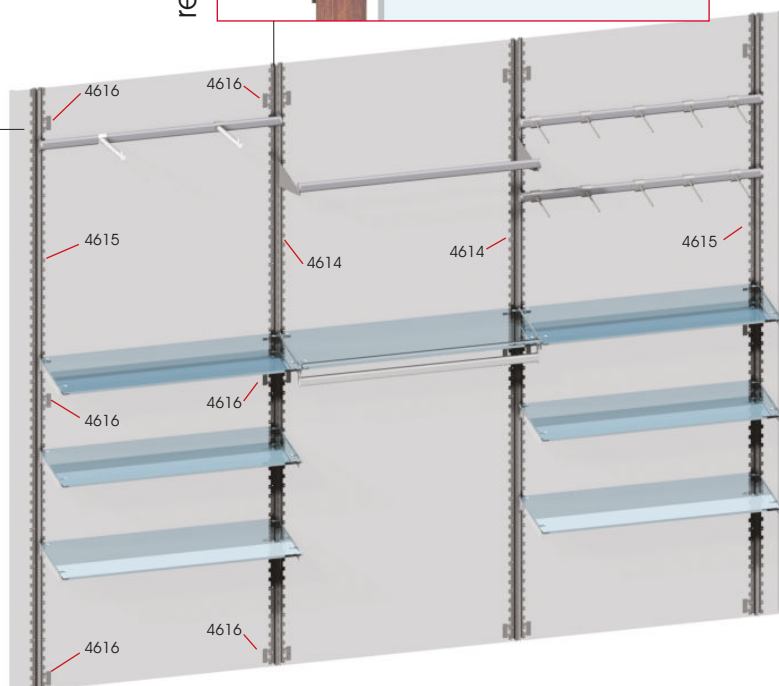
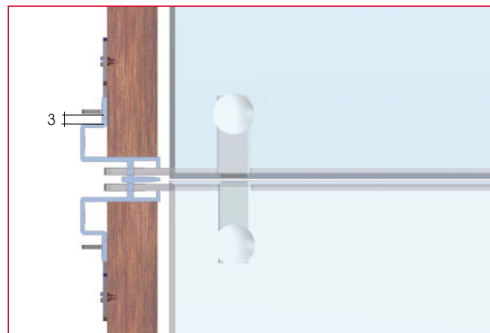

COLOCACIÓN DE LOS GANCHOS 4616 Y 4635

- el taladro central del gancho 4616 corresponde al paso de la cremallera: 37 mm.
- utilizar 4 ó 6 ganchos por panel dependiendo de su medida
- la distancia de los ganchos del borde del panel puede variar: se recomienda 36 mm.

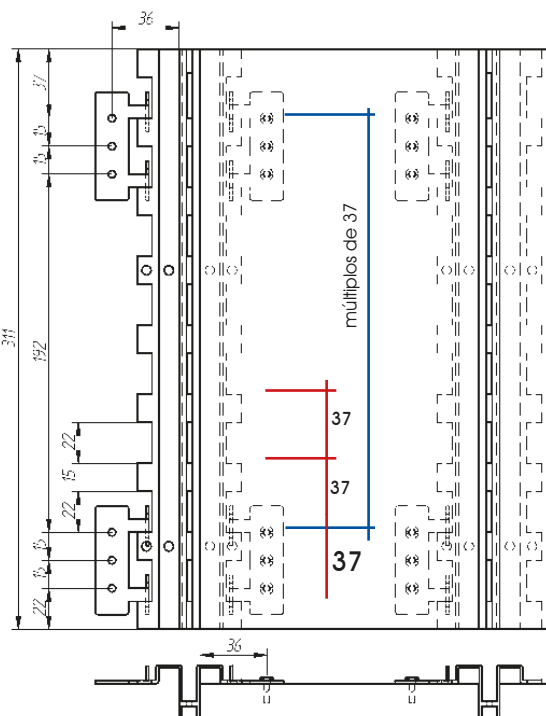
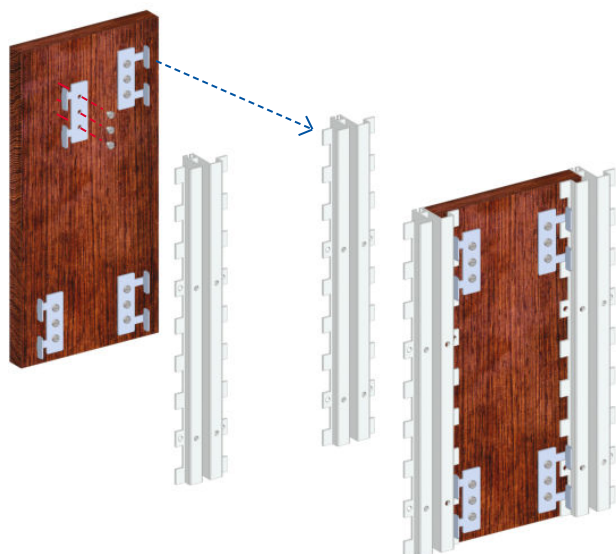

KADÍ EMPOTRABLE ALUMINIO

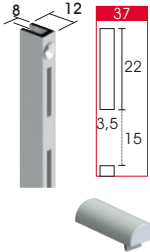

GUÍA CREMALLERA EMPOTRABLE
 GUIDE DE GRILLE ENCASTRÉ
 RECESSED RACK GUIDE
 GUIDA RACK AD INCASSO

4567/1.. 5m
 4567/102 2.5m

REMATE FINAL PARA 4567
 CABOCHON POUR 4567
 END-CAP FOR 4567
 COPRITESTA PER 4567
 84567/0..

PL. M ALU. M ALL. NAT	PL. BR ALU. BR ALL. LUC	BLANCO BLANC WHITE	NEGRO NOIR BLACK	COLOR COULEUR COLOR COLORE
01	02	0B	0N	0P

Al	5 m	12x8	€/m
----	-----	------	-----

o		o	o	o
	o			
			o	o



KADÍ COLUMNNA



GUÍA PANELABLE 1 CANAL
 CRÉMAILLÈRE SIMPLE PERFORATION
 RACK SINGLE CHANNEL
 CREMAGLIERA FORATURA SEMPLICE

4600/1.. 5m
 4600/142 2.5m



PL. BR ALU. BR ALL. LUC	PL. M ALU. M ALL. NAT	BLANCO BLANC WHITE	NEGRO NOIR BLACK	COLOR COULEUR COLOR COLORE
02	01	0B	0N	0P

Al	2.5-5m	19,5x36	€/m
----	--------	---------	-----

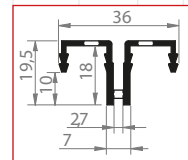

GUÍA FINAL PANELABLE 1 CANAL
 CRÉMAILLÈRE FINALE SIMPLE PERFORATION
 FINAL RACK SINGLE CHANNEL
 CREMAGLIERA FINALE FORATURA SEMPLICE

4602/1.. 5m
 4602/142 2.5m

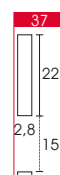

Al	2.5-5m	19,5x21	€/m
----	--------	---------	-----

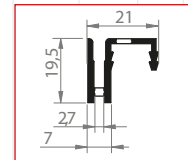

GUÍA PANELABLE 2 CANALES
 CRÉMAILLÈRE DOUBLE PERFORATION
 RACK DOUBLE CHANNEL
 CREMAGLIERA FORATURA DOPPIA

4601/1.. 5m
 4601/142 2.5m

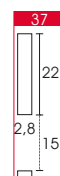

Al	2.5-5m	19,5x41	€/m
----	--------	---------	-----

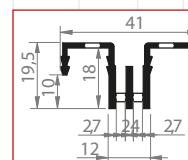

KADÍ COLUMNNA

GUÍAS-CREMALLERA - CRÉMAILLÈRES
 RACKS - PROFILI CREMAGLIERA

PL. M ALU. M ALL. NAT	BLANCO BLANC WHITE	NEGRO NOIR BLACK	COLOR COULEUR COLOR COLORE
01	0B	0N	0P

Al	5 m	12x12	€/m
----	-----	-------	-----

o	o	o	o
---	---	---	---

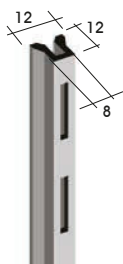
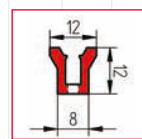

GUÍA CREMALLERA COLUMNNA
 CRÉMAILLÈRE COLONNE
 RACK FOR COLUMNS
 CREMAGLIERA COLONNE

4606/1..

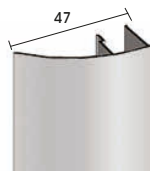

TAPA DE ALUMINIO
 PROFIL À RECOUVREMENT
 COVER PROFILE
 PROFILO COPERTINA

*4603/1..

Al	5 m	19,5x47	€/m
----	-----	---------	-----

∞	4600-4601-4602	
---	----------------	--

*o	*o	*o	*o
----	----	----	----

TAPA 4603+4600
 CABOCHON 4603+4600
 END-CAP 4603+4600
 COPRITESTA 4603+4600

*4604/0..

Fe	∞	4600-4603	€/u
----	---	-----------	-----

INOX SAT	INOX SAT	S.S.S.	INOX SAT	
28	Fe	∞	4600-4601-4602	€/u



GRAPA PARA COLGAR PANELES
 CROCHET POUR ACCROCHER PANNEAUX
 HOOK TO HANG WOOD PANELS
 GANCIO PER APPENDERE PANNELLI

4607/028

KADÍ *VÉRTICE

CASQUILLO - INSERT VERTICAL
 VERTICAL SOCKET - BOCCOLA VERTICALE

CR. BRILLO	CR. POLI	BR. CHR	CR. LUC.
32			

Zn	90x30 mm	€/u
----	----------	-----

*o	*o	*o	*o
----	----	----	----



CASQUILLO VERTICAL
 INSERT VERTICAL
 VERTICAL SOCKET
 BOCCOLA VERTICALE

*4699/0..



BOTONES PLÁSTICO PARA PANEADO



BOTÓN IZQUIERDO
 CROCHET GAUCHE
 DE MAINTIEN
 LEFT PANEL HOOK
 FERMAPANNELLO SINISTRO

*4780/009

PLÁSTICO	PLASTIQUE	PLASTIC	PLASTICA
----------	-----------	---------	----------

plas	∞	CLASSIC-OMEGA-ALA	€/u
------	---	-------------------	-----

10 - 16 mm	
------------	--

09	*o
----	----

BOTÓN DERECHA
 CROCHET DROIT DE MAINTIEN
 RIGHT PANEL HOOK
 FERMAPANNELLO DESTRO

*4781/009

*o	
----	--

BOTÓN CENTRAL
 CROCHET DOUBLE DE MAINTIEN
 DOUBLE PANEL HOOK
 FERMAPANNELLO DOPPIO

*4782/009

*o	
----	--

*o	
----	--

KADÍ OMEGA

OMEGA



POSIBILIDAD DE COLOCAR
DIRECTAMENTE A PARED

OMEGA FINAL



POSIBILIDAD DE COLOCAR
DIRECTAMENTE A PARED

DOBLE OMEGA



POSIBILIDAD DE COLOCAR
DIRECTAMENTE A PARED



KADÍ ALA

ALA



DOBLE ALA



GUÍA PANELABLE 1 CANAL
CRÉMAILLÈRE SIMPLE PERFORATION
RACK SINGLE CHANNEL
CREMAGLIERA FORATURA SEMPLICE
4574/1..

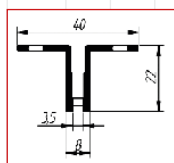

GUÍA FINAL PANELABLE
1 CANAL
CRÉMAILLÈRE FINALE SIMPLE
PERFORATION
FINAL RACK SINGLE CHANNEL
CREMAGLIERA FINALE FORATURA
SEMPLICE
4566/1..

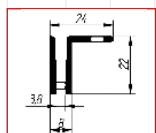

REMATE FINAL
CABOCHON
END-CAP
COPRITESTA
4575/009 GRIS

Al 5 m 46x22 €/m

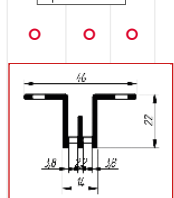

REMATE FINAL DOBLE
CABOCHON DOBLE
DOUBLE-ND-CAP
COPRITESTA DOPPIO
4577/009

plas ∞ 4576 €/u



GUÍA PANELABLE 1 CANAL
CRÉMAILLÈRE SIMPLE PERFORATION
RACK SINGLE CHANNEL
CREMAGLIERA FORATURA SEMPLICE
4608/1..

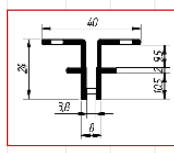

GUÍA PANELABLE 2 CANALES
CRÉMAILLÈRE DOUBLE
PERFORATION
RACK DOUBLE CHANNEL
CREMAGLIERA FORATURA DOPPIA
4609/1.. doble

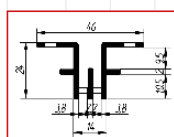

KADÍ DUO

DUO

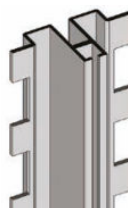

DOBLE DUO

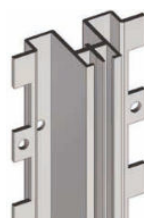

GUÍA PANELABLE 1 CANAL
CRÉMAILLÈRE SIMPLE PERFORATION
RACK SINGLE CHANNEL
CREMAGLIERA FORATURA SEMPLICE
4615/1..

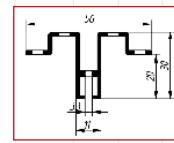

REMATE FINAL
CABOCHON
END-CAP
COPRITESTA
4617/0..

plas ∞ 4615 €/u

GUÍA PANELABLE 2 CANALES
CRÉMAILLÈRE DOUBLE PERFORATION
RACK DOUBLE CHANNEL
CREMAGLIERA FORATURA DOPPIA
4614/1..

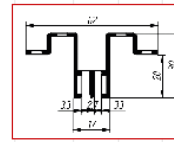

REMATE FINAL
CABOCHON
END-CAP
COPRITESTA
4613/0..

plas ∞ 4614 €/u

09/GRIS

GRAPA PARA COLGAR PANELES
CROCHET POUR ACCROCHER PANNEAUX
HOOK TO HANG WOOD PANELS
GANCIO PER APPENDERE PANNELLI
4616/034
PARA MADERA DE GROSOR 19mm
4635/034
PARA MADERA DE
GROSOR 10mm

ZINCADO
PL. ZINK
ZINK PL.
ZINCATO
34

CR.BLLO CR.FOIL CR.CH CR.ILC. B.LNO B.WBL B.WE COLOR COULEUR COLOR COLORE CR.MATE CR.M M.CHR CR.OPAC

KADÍ HIERRO EMPOTRABLES

GUÍA EMPOTRABLE 1 CANAL
CRÉMAILLÈRE SIMPLE PERFORATION
RACK SINGLE CHANNEL
CREMAGLIERA FORATURA SEMPLICE
4605/25.

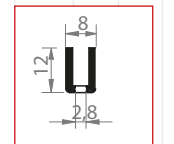

GUÍA EMPOTRABLE 2 CANALES
CRÉMAILLÈRE DOUBLE PERFORATION
RACK DOUBLE CHANNEL
CREMAGLIERA FORATURA DOPPIA
4610/2..

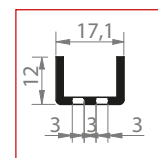

POSIBILIDAD DE COLOCAR DIRECTAMENTE A PARED

Fe 2.5 m 17,1x12 €/u

KADÍ TUBULAR

CARTELAS "TUBULAR" TUBO 30X10

CR. BRILLO	PLÁSTICO	CR. MATE	BLANCO	NEGRO	COLOR
CR. POLI	PLASTIC	CR. M	BLANC	NOR	COULEUR
CR. LUC.	PLASTICA	M. CHR	WHITE	BLACK	COLOR
		CR. OPAC	BANCO	NERO	COLORE
32	09	31	0B	0N	0P

CARTELA ESTANTE VIDRO
SUPPORT TABLETTES VERRE
GLASS SHELF BRACKET
MENSOLA RIPIANO VETRO

4583/0.. 28 cm

Fe	8-10 mm	200x292	€/u
----	---------	---------	-----

4647

CARTELA
SUPPORT
BRACKET
MENSOLA

4582/0.. 32 cm

Recomendada con cremalleras DUO
Recommandée avec crémaillères DUO
Recommended with racks DUO
Raccomandata con cremagliera DUO

Fe	€/u
∅	2556-358

VENTOSA
TRANSPARENTE
VENTOUSE
SUCTION
VENTOSA

2556/009

Ventosas y pasadores no incluidos
Ventouses et broches NO INCLUS
Suctions and pins not included
Ventose e perni non inclusi

∅	4582-4583-4584
plas	∅ 14

PASADOR ESTANTE MADERA
BROCHES À RESSORT
PIN WOOD SHELF
PERNO RIPIANO LEGNO

358/000

∅	4582-4583-4584
Fe	∅ 5x40

PERROQUET PLANO
PENDERIE FRONTAL
STRAIGHT ARM
APPENDERIA FRONTALE

4587/0.. 35 cm

Fe	350 mm	€/u
----	--------	-----

PERROQUET PLANO "T"
PENDERIE LATERAL "T"
LATERAL STRAIGHT ARM "T"
APPENDERIA LATERALE "T"

4588/0.. 35 cm

Fe	350x600 mm	€/u
----	------------	-----

PERROQUET PLANO "Z"
PENDERIE FRONTAL "Z"
STRAIGHT ARM "Z"
APPENDERIA FRONTALE "Z"

4589/0.. 35 cm

Fe	350 mm	€/u
----	--------	-----

CARTELA + BARRA PENDERIE
SUPPORT + BARRE PENDERIE
BRACKET + HANGING BAR
MENSOLA + APPENDERIA

4584/0.. 32 cm

Fe	∅ 4585(30x10)	320 mm	€/u
----	---------------	--------	-----

CARTELA BARRA PENDERIE
SUPPORT BARRE PENDERIE
BRACKET HANGING BAR
MENSOLA APPENDERIA

4590/..

Ventosas y pasadores no incluidos
Ventouses et broches NO INCLUS
Suctions and pins not included
Ventose e perni non inclusi

Fe	∅ 4585(30x10)	320 mm	€/u
----	---------------	--------	-----

CARTELA BARRA ACCESORIOS
SUPPORT BARRE ACCESSOIRES
BRACKET FOR ACCESSORIES ROD
MENSOLA TUBO PORTA-ACCESSORI

4591/0..

Fe	∅ 4585(30x10)	60 mm	€/u
----	---------------	-------	-----

CARTELA BARRA PENDERIE
SUPPORT BARRE PENDERIE
BRACKET HANGING BAR
MENSOLA APPENDERIA

4584/0.. 32 cm

Fe	∅ 4585(30x10)	320 mm	€/u
----	---------------	--------	-----

CARTELA BARRA PENDERIE
SUPPORT BARRE PENDERIE
BRACKET HANGING BAR
MENSOLA APPENDERIA

4590/..

Ventosas y pasadores no incluidos
Ventouses et broches NO INCLUS
Suctions and pins not included
Ventose e perni non inclusi

Fe	∅ 4585(30x10)	320 mm	€/u
----	---------------	--------	-----

CARTELA BARRA ACCESORIOS
SUPPORT BARRE ACCESSOIRES
BRACKET FOR ACCESSORIES ROD
MENSOLA TUBO PORTA-ACCESSORI

4591/0..

Fe	∅ 4585(30x10)	60 mm	€/u
----	---------------	-------	-----

CARTELA BARRA ACCESORIOS
SUPPORT BARRE ACCESSOIRES
BRACKET FOR ACCESSORIES ROD
MENSOLA TUBO PORTA-ACCESSORI

4591/0..

Fe	∅ 4585(30x10)	60 mm	€/u
----	---------------	-------	-----

CARTELAS "PLANAS" TUBO 30X10 HIERRO

CR. BRILLO	PL. M	CR. MATE	BLANCO	NEGRO	COLOR
CR. POLI	ALU. M	CR. M	BLANC	NOR	COULEUR
CR. LUC.	ALU. M	M. CHR	WHITE	BLACK	COLOR
	ALL. NAT	CR. OPAC	BANCO	NERO	COLORE
32	01	31	0B	0N	0P

CARTELA BARRA PENDERIE
SUPPORT BARRE PENDERIE
BRACKET HANGING BAR
MENSOLA APPENDERIA

30x10 mm (4585)

Fe	∅ 4585(30x10)	320 mm	€/u
----	---------------	--------	-----

4648/0.. derecha
droite/right/destra

4647/0.. izquierda
gauche/left/sinistra

CARTELA BARRA ACCESORIOS
SUPPORT BARRE ACCESSOIRES
BRACKET FOR ACCESSORIES ROD
MENSOLA TUBO PORTA-ACCESSORI

Fe	∅ 4585(30x10)	€/u
----	---------------	-----

4580/0.. derecha
droite/right/destra

4581/0.. izquierda
gauche/left/sinistra

TUBO RECTANGULAR
TUBE RECTANGULAIRE
RECTANGULAR TUBE
TUBO RETTANGOLARE

4260/122

Inx	6 m	30x10x1,5	€/m
-----	-----	-----------	-----

TAPA FINAL CON TOPE
EMBOUT AVEC RETENTION
END-CAP WITH STOP
COPRITESTA + RETENZIONE

4586/0..

Fe	∅ 4585	40x10 mm	€/u
----	--------	----------	-----

CARTELAS "PLANAS" TUBO 30X10 ALUMINIO

SET DE 2 CARTELAS
LOT DE 2 SUPPORTS
SET OF 2 BRACKETS
SET DI 2 MENSOLE

4866/0..

Fe	?? mm	∅ 4900	€/u
----	-------	--------	-----

SET DE 2 CARTELAS
LOT DE 2 SUPPORTS
SET OF 2 BRACKETS
SET DI 2 MENSOLE

4868/0..

Fe	?? mm	∅ 4900	€/u
----	-------	--------	-----

TUBO RECTANGULAR 30X10MM
TUBE RECTANGULAIRE 30X10
RECTANGULAR TUBE 30X10
TUBO RETTANGOLARE 30X10

4900/10.

Al	6 m	30x10	€/m
----	-----	-------	-----

TAPA PARA TUBO 30X10MM
CAPUCHON DE TUBE 30X10
TUBE CAP 30X10
TAPPO DEL TUBO 30X10

4904/00.

Fe	92 mm	∅ 4900	€/u
----	-------	--------	-----

ACCESORIOS COMUNES 30X10

PERROQUET PLANO
PENDERIE FRONTAL
STRAIGHT ARM
APPENDERIA FRONTALE

4592/0..

Fe	∅ 4585	350 mm	€/u
----	--------	--------	-----

PERROQUET INCLINADO
PERROQUET INCLINEE
SLOPING ARM
APPENDERIA INCLINADA

4593/0..

Fe	∅ 4585	400 mm	€/u
----	--------	--------	-----

GANCHO
CROCHET
HOOK
BARRETTA

5588/0.. 15 cm

4594/0.. 20 cm

5589/0.. 25 cm

5590/0.. 30 cm

Fe	∅ 4585	€/u
----	--------	-----

GANCHO PORTAPRECIO
CROCHET PORTAPRIX
HOOK LABEL-HOLDER
BARRETTA PORTAPREZZO

5591/0.. 15 cm

5592/0.. 20 cm

4597/0.. 25 cm

5593/0.. 30 cm

Fe	∅ 4585-382	€/u
----	------------	-----

PORTAPRECIO
PORTAPRIX
LABELHOLDER
PORTAPREZZO

382/009

plas	40x50 mm	€/u
------	----------	-----

PLÁSTICO
PLASTIC
PLASTICA
09

KADÍ CARTELAS

CARTELAS ESPECIALES "VIDRIO"

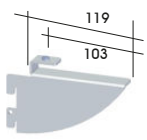

CARTELA ESTANTE VIDRIO
SUPPORT TABLETTES VERRE
GLASS SHELF BRACKET
MENSOLA RIPIANO VETRO
4645/0.. derecha
droite/right/destra
4646/0.. izquierda
gauche/left/sinistra

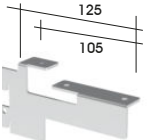

CARTELA ESTANTE VIDRIO
SUPPORT TABLETTES VERRE
GLASS SHELF BRACKET
MENSOLA RIPIANO VETRO
4622/0.. derecha
droite/right/destra
4623/0.. izquierda
gauche/left/sinistra

CARTELAS ESPECIALES PARA PHARMA, CREMALLERA DUO, Y ELECTRIFICADO. (APTO PARA TODOS LOS SISTEMAS KADÍ)



CARTELA SUPPORT BRACKET MENSOLA
5844/... derecha
droite/right/destra
5845/... izquierda
gauche/left/sinistra

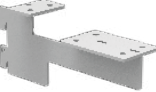

5846/... doble
double/double/doppio



SE RECOMIENDA ESTANTE DE VIDRIO TEMPLADO DE 30CM DE PROFUNDIDAD

CARTELA FINAL ANTIVUELCO
SUPPORT FINAL ANTIBASCULAMENT
FINAL BRACKET ANTITIPPING
MENSOLA FINALE ANTIRIBALTAMENTO
***4618/3..**



SE RECOMIENDA ESTANTE DE VIDRIO TEMPLADO DE 30CM DE PROFUNDIDAD

CARTELA INTERMEDIA ANTIVUELCO
SUPPORT INTERMÉDIAIRE ANTIBASCULAMENT
INTERMEDIATE BRACKET ANTITIPPING
MENSOLA INTERMEDIA ANTIRIBALTAMENTO
***4619/3..**

CARTELAS ESPECIALES "MADERA"

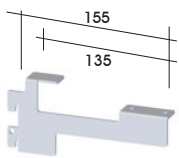

CARTELA ESTANTE MADERA
SUPPORT TABLETTES BOIS
WOOD SHELF BRACKET
MENSOLA RIPIANO LEGNO
4620/0.. derecha
droite/right/destra
4621/0.. izquierda
gauche/left/sinistra

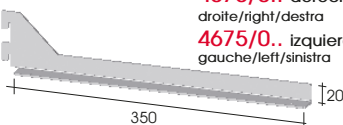

CARTELA ESTANTE MADERA
SUPPORT TABLETTES BOIS
WOOD SHELF BRACKET
MENSOLA RIPIANO LEGNO
4676/0.. derecha
droite/right/destra
4675/0.. izquierda
gauche/left/sinistra

CR. BRILLO	INOX SAT	SAT	CR. MATE	BLANCO	NEGRO	COLOR
CR. POLI	INOX SAT	S.S.S.	CR. M	BLANC	NOIR	COULEUR
CR. ILLUC.	INOX SAT	INOX SAT	CR. OPAC	WHITE	BLACK	COLOR
32	28	31	0B	0N	0P	

Fe	8-10 mm	119 mm	€/u

Fe	8-10 mm	125 mm	€/u

Fe	8-10 mm	14,9 cm	€/u
----	---------	---------	-----

Fe	8 mm	€/u
----	------	-----

Fe	8 mm	€/u
----	------	-----

Fe	19 mm	155 mm	€/u
----	-------	--------	-----

Fe	19 mm	350 mm	€/u
----	-------	--------	-----

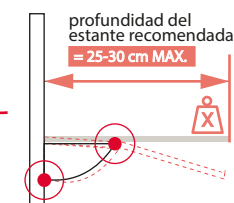

La profundidad de estante recomendado para las cartelas suspendidas de la gama "CARTELAS ESPECIALES VIDRIO" es de 25-30 cm max.

La profundidad del estante interfiere directamente en la capacidad y resistencia de aguante de las mismas cartelas y de todo el sistema.

"SILUETTE" PLEGADA PARA VIDRIO Y MADERA



CARTELA SUPPORT BRACKET MENSOLA
4692/0.. derecha
droite/right/destra
4691/0.. izquierda
gauche/left/sinistra



4694/0.. derecha
droite/right/destra
4693/0.. izquierda
gauche/left/sinistra



VENTOSA TRANSPARENTE
VENTOUSE
SUCTION
VENTOSA
2556/009

Fe	23 cm	€/u
----	-------	-----

Fe	28 cm	€/u
----	-------	-----

∞	4691-4692-4693-4694	€/u
	plás	∅ 14

CARTELAS "GRANDES PESOS" PARA VIDRIO Y MADERA



CARTELA GRANDES PESOS
SUPPORT GRAN POND
BRACKET HEAVY WEIGHT
MENSOLA GRANDI PESI
4652/0.. derecha
droite/right/destra
4653/0.. izquierda
gauche/left/sinistra

Fe	35 cm	€/u
----	-------	-----

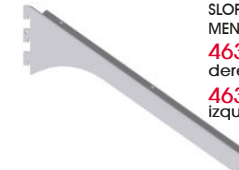

CARTELA INCLINADA 30°
SUPPORT INCLINÉE 30°
SLOPING BRACKET 30°
MENSOLA INCLINATA 30°
4632/0.. derecha
droite/right/destra
4633/0.. izquierda
gauche/left/sinistra

Fe	38 cm	€/u
----	-------	-----



CARTELA GRANDES PESOS
SUPPORT GRAN POND
BRACKET HEAVY WEIGHT
MENSOLA GRANDI PESI
4654/0.. derecha
droite/right/destra
4655/0.. izquierda
gauche/left/sinistra

Fe	42 cm	€/u
----	-------	-----



CARTELA GRANDES PESOS
SUPPORT GRAN POND
BRACKET HEAVY WEIGHT
MENSOLA GRANDI PESI
4656/0.. derecha
droite/right/destra
4657/0.. izquierda
gauche/left/sinistra

Fe	52 cm	€/u
----	-------	-----



VENTOSA TRANSPARENTE
VENTOUSE
SUCTION
VENTOSA
2556/009

∞	4652-4653-4654-4655	€/u
	plás	∅ 14



CARTELA SUPPORT BRACKET MENSOLA
***4650/0..** derecha
droite/right/destra
***4651/0..** izquierda
gauche/left/sinistra

Fe	30 cm	€/u
----	-------	-----

CAPACIDAD DE CARGA

Loading capacities - Capacités de chargement - Carichi massimi

FONDO ESTANTE, DEEPH SHELF, FOND DE TABLETTE, PROFONDITA RIPIANO

PESOS ORIENTATIVOS CARTELAS

hasta 20 cm hasta 25 cm hasta 30 cm hasta 35 cm hasta 40 cm hasta 50 cm

GANCHOS CARTELAS
HOOKS BRACKETS
CROCHET SUPPORTES
GANCI MENSOLE

2 ganchos
Cartelas empotrables, siluette y tubulares.

3 ganchos
Cartelas empotrables, siluette y tubulares.

3 ganchos con pliege
Cartelas para grandes pesos.

2 ganchos con vidrio suspendido o con perfil tipo 362

90 kg/est.

80 kg/est.

70 kg/est.

60 kg/est.

80 kg/est.

70 kg/est.

60 kg/est.

100 kg/est.

100 kg/est.

90 kg/est.

30 kg/est.

20 kg/est.

ALUSYSTEM recomienda el uso de vidrio templado para los estantes.

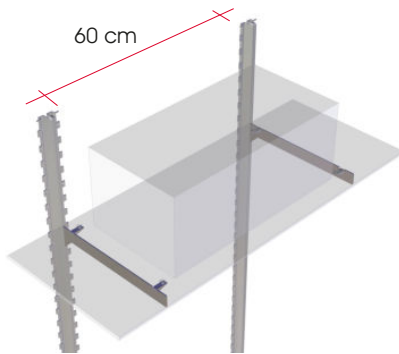

1 estante

1SELF 2 BRACKETS

1 TABLETTE 2 SUPPORTES

1 RIPIANO 2 MENSOLE

- peso distribuido encima del estante
- cremallera fijada a la pared (u otro soporte) en todos los puntos
- Pladur: **¡ATENCIÓN!** en caso de grandes pesos reforzar la pared o anclar a los montantes estructurales

- Weight distributed over the shelf
- Rack fixed to the wall (or other support) at all points
- Plasterboard: **ATTENTION!** for large weights to strengthen the wall metal structure and to anchor the racks to structural frames

- Poids réparti sur le tablette
- Crémallière fixée à la paroi (ou autre support) à tous les points
- Plaques de plâtre: **ATTENTION!** pour les grands poids de renforcer les montants structurelles du mur et fixée les crémaillères à la structure

- peso distribuito uniformemente sul ripiano
- profili cremagliera fissati alla parete (o ad altri tipi di supporto) in tutti i punti
- Cartongesso: **ATTENZIONE!** in caso di grandi pesi, rinforzare le parete e fissare i profili cremagliera ai montanti strutturali

- **¡ATENCIÓN!** peso soportado por la cartela intermedia = suma del peso de los dos estantes dividido por 2

- **ATTENTION!** weight supported by intermediate gusset = sum of the weight of the two shelves divided by 2
- **ATTENTION!** poids supporté par intermédiaire gousset = somme des poids des deux plateaux divisés par 2

- **ATTENZIONE!** peso sopportato dalla mensola intermedia = somma del peso dei due ripiani diviso per 2

La resistencia de la cartela está determinada por:

1. el número de enganches a la cremallera (2 o 3),
2. la forma de la cartela (plegada más resistente)
3. el largo de la cartela (más corta más peso)

Cuanto más el baricentro del peso se coloca lejos de las guías, mayor es el esfuerzo que tiene que soportar la cartela.

Ejemplo: un peso de 20 kg a 30 cms de la cremallera corresponde a un peso de 40 kg a 15 cms o de 60 kg a 10 cms.

The strength of the bracket is determined by:

1. the number of hooks to the rack (2 or 3),
2. the shape of the bracket (folded more resistant)
3. the length of the bracket (shorter heavier)

The more the centroid of the weight is placed far from the guidelines, the greater the effort you have to put the bracket.

Example: the ability to withstand a weight of 20 kg to 30 cms of the slotted rack corresponds to a weight of 40 kg to 15 cms or 60 kg to 10 cms.

La force du support est déterminé par:

1. le nombre de crochets de la crémaillère (2 ou 3),
2. la forme de la console (plié plus résistants)
3. la longueur de la console (plus lourd plus courte)

Le plus le centre de gravité de la masse est placée loin de les crémaillères, plus les efforts que doit supporter le support.

Exemple: la capacité à résister le poids de 20 kg à 30 cm de la crémaillère correspond à un poids de 40 kg à 15 cm ou de 60 kg à 10 cm.

La resistenza delle mensole è determinata da:

1. numero di ganchi per il profilo-cremagliera
2. forma delle mensole (le mensole piegate sono più resistenti)
3. la lunghezza delle mensole (più corte più resistenti)

Quanto maggiore è la distanza del baricentro del carico dai profili cremagliera tanto maggiore è lo sforzo che le mensole devono sopportare.

Esempio: la capacità di sopportare un peso di 20 kg a 30 cm dal profilo cremagliera corrisponde a 40 kg a 15 cm o di 60 kg a 10 cm.

2 estantes + cartela intermedia

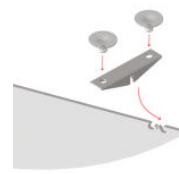

PESOS ORIENTATIVOS CREMALLERAS

Cremalleras DUO, Elektric, Omega, Ala y CR (4600 y 4601):

Con un peso de 100 kg repartido entre dos cremalleras no se han observado deformaciones importantes en las mismas.

Con un peso de 120 kg se ha detectado una deformación de 2/3° de la mismas. No se han detectado roctura con más de 200 kg.

DUO, Elektric, Omega, Ala and CR (4600 and 4601) slotted racks:

With a weight of 100 kg divided between two racks no significant deformation was observed.

With a weight of 120 kg has been detected deformation 2/3°.

No breakage detected more than 200 kg.

Crémaillères DUO, Elektric, Omega, Ala et CR (4600 et 4601):

Avec un poids de 100 kg divisé entre deux racks pas de déformation significative n'a été observée.

Avec un poids de 120 kg a été détectée déformation de 3.2°.

Pas de rupture détecté plus de 200 kg.

Profili cremagliera DUO, Elektric, Omega, Ala e CR (4600 e 4601):

Con un carico di 100 kg ripartito fra due profili cremagliera non si osservano deformazioni importanti.

Con 120 kg si è registrata un'inclinazione del ripiano di 2/3°

Con più di 200 kg non si è arrivati alla rottura dei profili cremagliera.

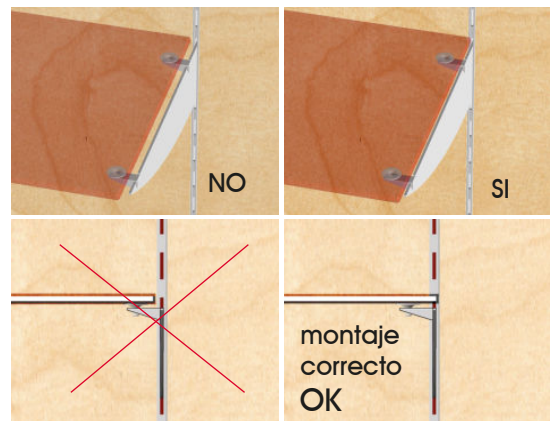

CARTELA PASANTE BARRA COLGADORA (36X18)

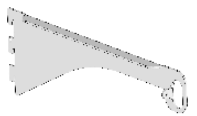

CARTELA BARRA PENDERIE
SUPPORT BARRE PENDERIE
BRACKET HANGING BAR
MENSOLA APPENDERIA

5628/0.. derecha
droite/right/destra

5629/0.. izquierda
gauche/left/sinistra

	CR. BRILLO CHR. POLI BR. CHR. CR. LUC.	CR. MATE CHR. M M. CHR. CR. OPAC	BLANCO BLANC WHITE BIANCO	NEGRO NOR BLACK NERO	COLOR COULEUR COLOR COLORE
	32	31	OB	ON	OP

Fe	32 cm	∞	4547 (36x18)	€/u
----	-------	---	--------------	-----



***4628/0..** derecha
droite/right/destra

***4629/0..** izquierda
gauche/left/sinistra

CARGA MEDIA - BAJA

*o	*o	*o	*o	*o
----	----	----	----	----

CARTELA FINAL BARRA COLGADORA (36X18)



CARTELA BARRA CUELGE
SUPPORT DE BARRE DE
SUSPENSION
HANGING BAR BRACKET
STAFFA PER BARRA SOSPESA

4790/0.. derecha
droite/right/destra

4791/0.. izquierda
gauche/left/sinistra

CARGA MEDIA - ALTA

Fe	32 cm	∞	4547 (36x18)	€/u
----	-------	---	--------------	-----

o	*o	o	o	o
---	----	---	---	---



CARTELA BARRA CUELGE
SUPPORT DE BARRE DE
SUSPENSION
HANGING BAR BRACKET
STAFFA PER BARRA SOSPESA

4799/0.. intermedia
inter./inter./inter.

CARGA MEDIA - ALTA

Fe	32 cm	∞	4547 (36x18)	€/u
----	-------	---	--------------	-----

o	*o	o	o	o
---	----	---	---	---

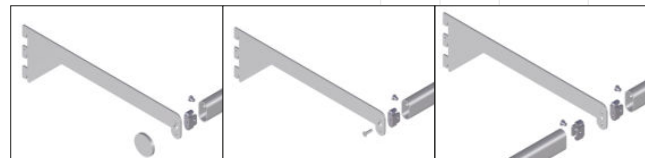

EMBELLECEDOR 4720 OPCIONAL
VIS-DISQUE DE FINITION 4720 OPTIONNEL
SCREW-EMBELLISHER 4720 OPTIONAL
DISCO-VITE 4720 OPZIONALE

ESTÁNDAR
STANDARD

CARTELA PASANTE BARRA ACCESORIOS (36X18)



CARTELA BARRA ACCESORIOS
SUPPORT BARRE ACCESSOIRES
BRACKET FOR ACCESSORIES ROD
MENSOLA TUBO PORTA-ACCESSORI

4626/0..

	CR. BRILLO CHR. POLI BR. CHR. CR. LUC.	CR. MATE CHR. M M. CHR. CR. OPAC	BLANCO BLANC WHITE BIANCO	NEGRO NOR BLACK NERO	COLOR COULEUR COLOR COLORE
	32	31	OB	ON	OP

Fe	∞	4547(36x18)	43 mm	€/u
----	---	-------------	-------	-----

o	*o	o	o	o
---	----	---	---	---

CARTELA BARRA ACCESORIOS
SUPPORT BARRE ACCESSOIRES
BRACKET FOR ACCESSORIES ROD
MENSOLA TUBO PORTA-ACCESSORI

4627/0..

Fe	∞	4547(36x18)	67 mm	€/u
----	---	-------------	-------	-----

o	o	o	o	o
---	---	---	---	---

TUBO PASANTE
TUBE PASSANTE
THROUGH TUBE
TUBO PASSANTE

4722 / 4721



CARTELA FINAL BARRA ACCESORIOS (36X18)



CARTELA BARRA ACCESORIOS
SUPPORT BARRE ACCESSOIRES
BRACKET FOR ACCESSORIES ROD
MENSOLA TUBO PORTA-ACCESSORI

4716/0.. derecha
droite/right/destra

4717/0.. izquierda
gauche/left/sinistra

Fe	60mm	∞	4547 (36x18)	€/u
----	------	---	--------------	-----

o	*o	o	o	o
---	----	---	---	---

CARTELA BARRA ACCESORIOS
SUPPORT BARRE ACCESSOIRES
BRACKET FOR ACCESSORIES ROD
MENSOLA TUBO PORTA-ACCESSORI

4715/0.. intermedia
inter./inter./inter.

o	*o	o	o	o
---	----	---	---	---

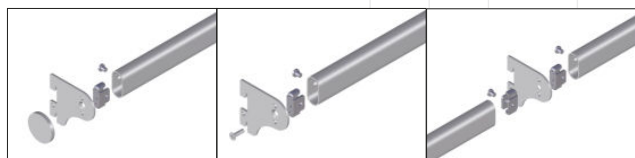

EMBELLECEDOR 4720 OPCIONAL
VIS-DISQUE DE FINITION 4720 OPTIONNEL
SCREW-EMBELLISHER 4720 OPTIONAL
DISCO-VITE 4720 OPZIONALE

ESTÁNDAR
STANDARD

TUBO OVALADO 36X18

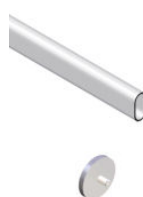

TUBO OVAL 36x18 mm
TUBE OVALE 36X18 mm
OVAL TUBE 36X18 mm
TUBO OVALE 36X18 mm

4547/1.. 1M €/m

4547/3.. 3M €/u

Fe	3 m	36x18x1,5
----	-----	-----------

o	o	o
---	---	---

TORNILLO-EMBELLECEDOR
VIS-DISQUE DE FINITION
SCREW-EMBELLISHER
DISCO-VITE

4720/0..

∞	4590-4591/4716-4717	€/u
---	---------------------	-----

Fe	∅38	€/u
----	-----	-----

o	o	o
---	---	---

SE ACONSEJA NO UTILIZAR CON CREMALLERAS DOBLE TROQUEL
RECOMMANDÉ DE NE PAS UTILISER AVEC DES CRÉMAILLÈRES AVEC DOUBLE EFFORATION
RECOMMENDED NOT TO USE WITH RACKS WITH DOUBLE SLOT CHANNEL
NON RACCOMANDATO L'USO CON CREMAGLIERE CON FORATURA DOPPIA



TAPA FINAL
EMBOUT
END-CAP
COPRITESTA

4721/032

Fe	36x18	∞	4547 (36x18)	€/u
----	-------	---	--------------	-----

o	o	o	o	o
---	---	---	---	---



TAPA FINAL CON TOPE
EMBOUT AVEC RÉTENTION
END-CAP WITH STOP
COPRITESTA + RETENZIONE

4722/032

Zn	46x18	∞	4547 (36x18)	€/u
----	-------	---	--------------	-----

o	*o	o	o	o
---	----	---	---	---

Tube 4547 for hanging bars and lighting system profile 4745
Tube 4547 pour console penderie et profile éclairage 4745
Tubo 4547 per appendieria e profilo illuminazione 4745

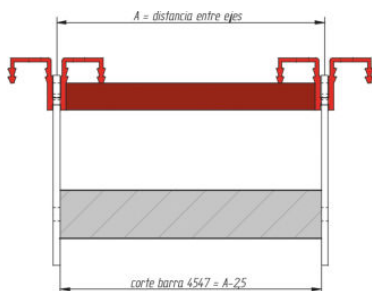

ACCESORIOS TUBO OVALADO 36X18



PERROQUET PLANO
PENDERIE FRONTAL
STRAIGHT ARM
APPENDERIA FRONTALE
3019/0..

PERROQUET INCLINADO
PERROQUET INCLINÉE
SLOPING ARM
APPENDERIA INCLINADA
3022/0..

GANCHO
CROCHET
HOOK
BARRETTA

3014/0.. 25 cm
3020/0.. 20 cm
3021/0.. 10 cm

GANCHO PORTAPRECIO
CROCHET PORTAPRIX
HOOK LABEL-HOLDER
BARRETTA PORTAPREZZO

3012/0.. 25 cm

PORTAPRECIO
PORTAPRIX
LABELHOLDER
PORTAPREZZO
382/009

BLOQUEO GANCHO
BLOCCAGE BROCHE
HOOK SECURITY LOCK
BLOCCO SICUREZZA GANCIO
373/00N

BLOQUEO GANCHO DOBLE
BLOCCAGE BROCHE DOUBLE
DOUBLE HOOK SECURITY LOCK
BLOCCO GANCIO DOPPIO
383/00N

IMÁN ESPECIAL DESBLOQUEO
UNLOCK MAGNET
UNLOCK MAGNET
MAGNETE DI SBLOCCO
384/000

TUBO OVALADO 30X15



TUBO OVAL 30x15 mm
TUBE OVALE 30X15 mm
OVAL TUBE 30X15 mm
TUBO OVALE 30X15 mm
*4639/132 100 cm *o

TAPA FINAL
EMBOUT
END-CAP
*4640/0.. *o

SOPORTE SUPERIOR
SUPPORT TUBE HAUTE
UPPER TUBE SUPPORT
SUPPORTO TUBO ALTO
*1400/0.. *o

SOPORTE LATERAL
SUPPORT TUBE LATÉRAL
SIDE TUBE SUPPORT
SUPPORTO TUBO LATÉRALE
*4723/032 *o

CR. BRILLO	PLÁSTICO	CR. MATE	BLANCO	NEGRO	COLOR
CR. POLI	PLASTIQUE	CHR. M	BLANC	NOR	COULEUR
CR. CH	PLASTICA	M. CHR	WHITE	BLACK	COLORE
CR. ILLC.	PLASTICA	CR. OPAC	BIANCO	NERO	COLORE
32	09	31	0B	0N	0P
Fe	∞	4547	300 mm	€/u	
		*o	o	o	
Fe	∞	4547	300 mm	€/u	
			o	o	
Fe	∞	4547	€/u		
		*o	o	o	
			o	o	
Fe	∞	4547-382	€/u		
		*o	o	o	
plas		40x50 mm	€/u		
					o
plas		∅6 mm	€/u		
					o
plas		∅6 mm	€/u		
					o
plas		373-383/00N	€/u		
					o
Fe	∞	3 m	30x15x1,5	€/m	
plas		∞ 4639 (30x15)	€/u		
		NEGRO			*o
Zn		∞ 4639 (30x15)	€/u		
					*o
Zn		∞ 4639 (30x15)	€/u		

PERROQUETES

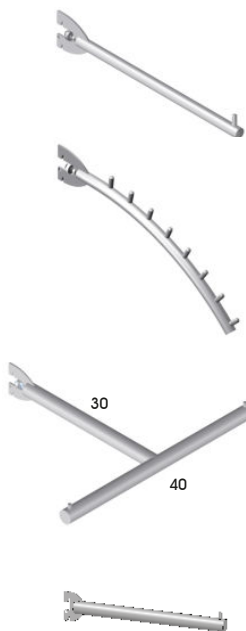

PERROQUET PLANO
PENDERIE FRONTAL
STRAIGHT ARM
APPENDERIA FRONTALE
4705/032

Sólo cremalleras
DUO ∞ 4614-4615 ∅16 330 mm
4705/D32

PERROQUET INCLINADO
PERROQUET INCLINÉE
SLOPING ARM
APPENDERIA INCLINADA
4706/032

Sólo cremalleras
DUO ∞ 4614-4615 ∅16 330 mm
4706/D32

PERROQUET PLANO "T"
PENDERIE LATÉRAL "T"
LATERAL STRAIGHT ARM "T"
APPENDERIA LATÉRALE "T"
4708/032

Sólo cremalleras
DUO ∞ 4614-4615 ∅25 300X400
4708/D32

PERROQUET PLANO
PENDERIE FRONTAL
STRAIGHT ARM
APPENDERIA FRONTALE
*4713/032 30 cm
*4714/032 20 cm

CR. BRILLO	BLANCO	NEGRO
CR. POLI	BLANC	NOR
CR. CH	WHITE	BLACK
CR. ILLC.	BIANCO	NERO
32	0B	0N
Fe	∞ NO "DUO"	
	∅16 330 mm	€/u
		o
Fe	∞ NO "DUO"	
	∅16 330 mm	€/u
		o
Fe	∞ NO "DUO"	
	∅25 300X400	€/u
		o
Fe	∞ NO "DUO"	
	∅25	€/u
		*o
		*o
Fe	€/u	ZINCADO PL. ZNK ZINK PL. ZINCATO 34
		o
∞ 4600-4601-4602 / 4608-4609 / 4566-4574-4576		
Fe	€/u	
		o
∞ 4614-4615		
Fe	€/u	
		o
∞ 4814-4815-4816		
Fe	€/u	
		o

SISTEMA PARA CUELGO DE MUEBLES

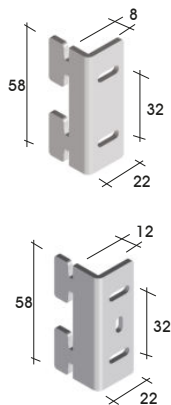

CARTELA MUEBLES
SUPPORT POUR MOBILE
FURNITURE BRACKET
MESNOLA PER MOBILI
4730/034

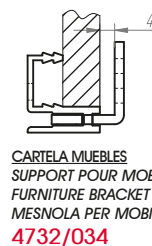

CARTELA MUEBLES
SUPPORT POUR MOBILE
FURNITURE BRACKET
MESNOLA PER MOBILI
4732/034

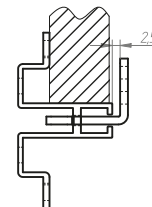

CARTELA MUEBLES
SUPPORT POUR MOBILE
FURNITURE BRACKET
MESNOLA PER MOBILI
4733/032

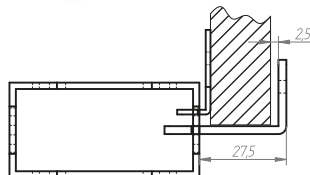
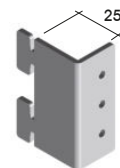

PERFIL 362 PARA SISTEMA KADÍ Y LAMAS

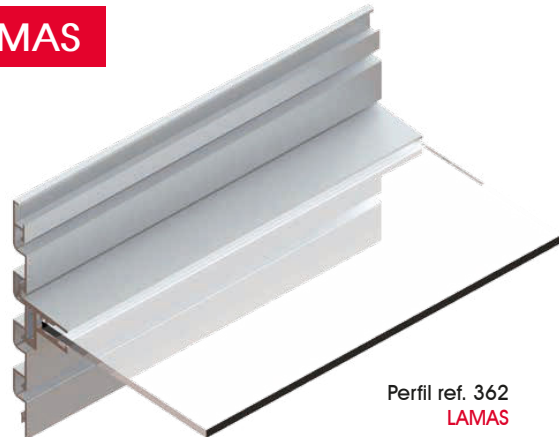
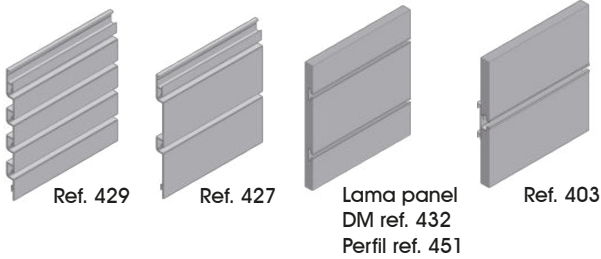

Perfil ref. 362
LAMAS

CARTELAS



kit 386

CREMALLERAS KADÍ - ELETRIC

SISTEMA ELECTRIFICADO

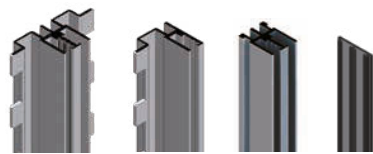

4870 4872 4874 4871

CARTELAS



Ref. 366/365

CREMALLERAS KADÍ

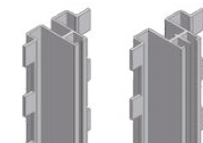

4615 4614

CARTELAS



Ref. 368/367

CREMALLERAS KADÍ

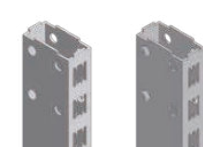

4814/4815 4816



Perfil ref. 362 + CARTELAS
KADI CREMALLERAS

CARTELAS



Ref. 364/363

CREMALLERAS KADÍ

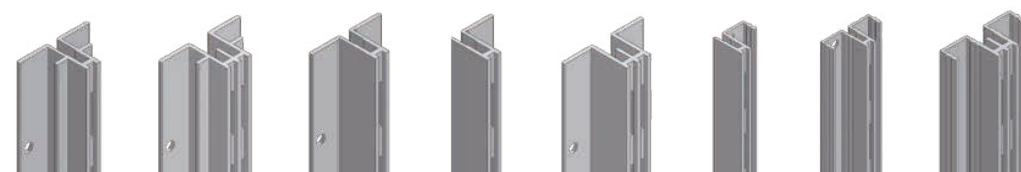

4608 4609 4574 4566 4576 4602 4600 4601

Perfil aluminio 362

- Admite estante de vidrio de 6 y 8 mm.
(SE RECOMIENDA VIDRIO DE SEGURIDAD).
- Admite iluminación LED en el canal del perfil.

Aluminum profile, 362
- Allows glass shelf 6 and 8 mm thickness.
(SAFETY GLASS IS RECOMMENDED)
- Allows LED lighting.

Profil en aluminium 362
- Permet étagère en verre de 6 et 8 mm d'épaisseur
(VERRE DE SÉCURITÉ EST RECOMMANDÉ)
- Permet l'éclairage LED

Profilo in alluminio, 362
- Ammette ripiani in vetro di 6 e 8 mm.
(SI RACCOMANDA L'USO DI VETRO SICURIZZATO)
- Ammette LEDs.

PERFIL 362

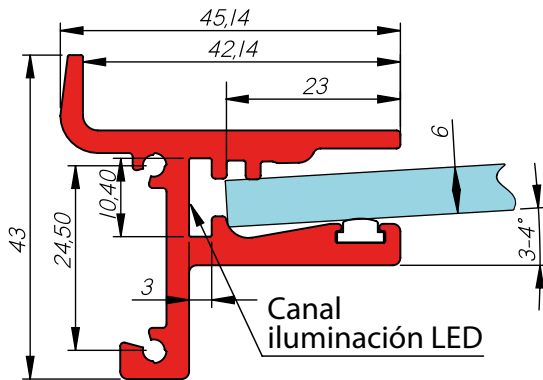
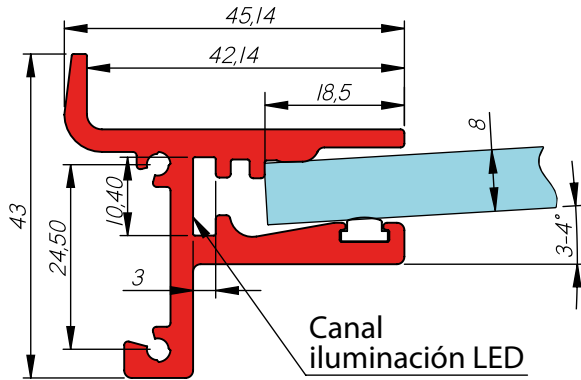

Ancho perfil 362 = Ancho vidrio
362 aluminum profile width = Glass width
Largeur du profil 362 = Largeur de verre
Larghezza profilo 362 = Larghezza di vetro

- Peso max. admitido según tipo de montaje, naturaleza del soporte (pared o mueble), vidrio y número de tornillos de fijación.
- La inclinación del estante puede variar según la carga.
- **Máxima carga para estante vidrio: 25 kg/ml.**
- **Máxima medida estante recomendada: 100 x 30 cm.**

- Max. admitted weight depending on assembly type, on nature of the support (wall or furniture), glass and number of screws used.
- Allows LED lighting.
- The shelf inclination may vary depending on the load.
- **Máx. weight for shelf glass shelf: 50 kg / ml.**
- **Maximum recommended shelf size: 100 x 30 cm.**

- Max. poids admis en fonction du type de montage, la nature du support (mur ou un meuble), le verre et le nombre de vis utilisées.
- Permet l'éclairage LED.
- L'inclinaison de l'étagère peut varier en fonction de la charge.
- **Poids maximum pour étagère en verre: 50 kg / ml.**
- **Taille maximale de l'étagère recommandée: 100 x 30 cm.**

- Peso massimo ammesso a seconda del tipo di montaggio, del tipo di supporto (parete o mobile), vetro o legno e del numero di viti di fissaggio.
- Ammette LEDs.
- L'inclinazione del ripiano può variare a seconda del peso.
- **Peso massimo de ripiano di vetro: 50 kg/ml.**
- **Dimensione massima raccomandata dello scaffale: 100 x 30 cm.**

PERFIL 362



PERFIL ALUMINIO.
PROFIL LAME D'ALUMINIUM
ALUMINIUM SLATWALL PROFILE
PROFILO DOGATO ALLUMINIO
*362/1..

Junta goma incluida
joint en caoutchouc inclus
rubber gasket included
giunta di gomma inclusa

PL. M	BLANCO	NEGRO	COLOR
ALU. M	BLANC	NOIR	COULEUR
ALL. NAT	WHITE	BLACK	COLOR
	BIANCO	NERO	COLORE
	01	0B	0N 0P

Al	6-8 mm	5 m	€/m
		∞ 361/109	

*o	*o	*o	*o
----	----	----	----

KADÍ CARTELAS



CARGA MEDIA - BAJA

CARTELA OMEGA / ALA / CLASSIC
SUPPORT OMEGA / ALA / CLASSIC
OMEGA / ALA / CLASSIC BRACKET
MENSOLA OMEGA / ALA
*364/0.. derecha
droite/right/destra
*363/0.. izquierda
gauche/left/sinistra

BLANCO	NEGRO	COLOR
BLANC	NOIR	COULEUR
WHITE	BLACK	COLOR
BIANCO	NERO	COLORE
	0B	0N 0P

Fe	∞ 362	€/u
----	-------	-----

*o	*o
*o	*o



CARGA MEDIA - BAJA

CARTELA DUO
SUPPORT DUO
DUO BRACKET
MENSOLA DUO
*366/0.. derecha
droite/right/destra
*365/0.. izquierda
gauche/left/sinistra

Fe	∞ 362	€/u
----	-------	-----

*o	*o
*o	*o



CARGA MEDIA - BAJA

CARTELA PHARMA / PHARMA DUO
SUPPORT PHARMA / PHARMA DUO
PHARMA / PHARMA DUO BRACKET
MENSOLA PHARMA / PHARMA DUO
*368/0.. derecha
droite/right/destra
*367/0.. izquierda
gauche/left/sinistra

Fe	∞ 362	€/u
----	-------	-----

*o	*o
*o	*o



Para perfil 362
KIT 2 cartelas:
DERECHA (con
conector) +
IZQUIERDA

KIT CARTELAS ESTANTE
VIDRIO CON
ILUMINACIÓN
KIT SUPPORTS VERRE
ILUMINATION
GLASS LIGHTING
BRACKETS KIT
KIT MENSOLE VETRO
ILLUMINAZIONE
*386/0..

Fe	∞ 362 - 4890	€/u
	68 mm medida útil	

*o	*o
----	----

KADÍ COLUMNAS

PL. M	BLANCO	NEGRO	COLOR
ALL. M	BLANC	NOR.	COULEUR
ALL. M	WHITE	BLACK	COLOR
ALL. NAT	B'ANCO	NERO	COLORE
01	0B	0N	0P

VERONA

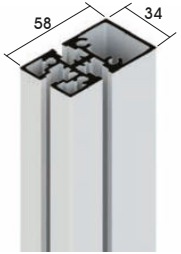

PERFIL ALUMINIO 3 CANALES
PROFIL EN ALUMINIUM 3 FENTES
ALUMINIUM PROFIL 3 SLOTS
PROFILO D'ALLUMINIO 3 CANALI
4520/1..

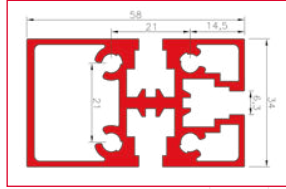

Al	6 m	∞	4606	€/m
----	-----	---	------	-----

	o	o	o	o
--	---	---	---	---

TAPA EMBELLECEDORA
EMBOUT
END-CAP
COPRITESTA
4521/0..

Fe	∞	4520	€/u
----	---	------	-----

	o	o	o
--	---	---	---

BASE FIJACIÓN SUELO
BASE FIXATION SOL
BASE
BASE FISSAGGIO SUOLO
4522/0..

Fe	∞	4520	€/u
----	---	------	-----

	o	o	o
--	---	---	---

BILBO

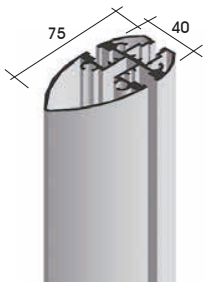

PERFIL ALUMINIO 3 CANALES
PROFIL EN ALUMINIUM 3 FENTES
ALUMINIUM PROFIL 3 SLOTS
PROFILO D'ALLUMINIO 3 CANALI
4510/1..

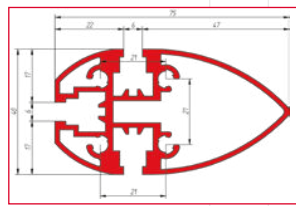

PRECIO COLOR = 9006

Al	6 m	∞	4606	€/m
----	-----	---	------	-----

	o	o	o	o
--	---	---	---	---

TAPA EMBELLECEDORA
EMBOUT
END-CAP
COPRITESTA
4511/0..

Fe	∞	4510	€/u
----	---	------	-----

	o	o	o
--	---	---	---

BASE FIJACIÓN SUELO
BASE FIXATION SOL
BASE
BASE FISSAGGIO SUOLO
4512/0..

Fe	∞	4510	€/u
----	---	------	-----

	o	o	o
--	---	---	---

MILAN

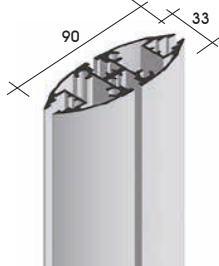

PERFIL ALUMINIO 3 CANALES
PROFIL EN ALUMINIUM 3 FENTES
ALUMINIUM PROFIL 3 SLOTS
PROFILO D'ALLUMINIO 3 CANALI
4505/1..

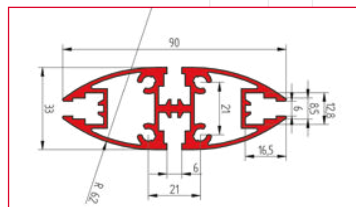

Al	6 m	∞	4606	€/m
----	-----	---	------	-----

	o	o	o	o
--	---	---	---	---

TAPA EMBELLECEDORA
EMBOUT
END-CAP
COPRITESTA
4506/0..

Fe	∞	4505	€/u
----	---	------	-----

	o	o	o
--	---	---	---

BASE FIJACIÓN SUELO
BASE FIXATION SOL
BASE
BASE FISSAGGIO SUOLO
4507/0..

Fe	∞	4505	€/u
----	---	------	-----

	o	o	o
--	---	---	---

CREMALLERA PARA COLUMNAS

PL. M	BLANCO	NEGRO	COLOR
ALL. M	BLANC	NOR.	COULEUR
ALL. NAT	B'ANCO	NERO	COLORE
01	0B	0N	0P

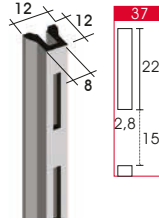

GUÍA CREMALLERA COLUMNAS
CRÉMAILLÈRE COLONNE
RACK FOR COLUMNS
CREMAGLIERA COLONNE
4606/1..

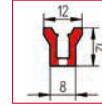

TORNILLO X GUÍA 4606
VIS FIXATION PROFIL 4606
SCREW x PROFIL 4606
VITE FISSAGGIO PROFILO 4606
4530/000

TORNILLO ACCESORIOS
VIS FIXATION ACCESSOIRES
SCREW x ACCESSORIES
VITE FISSAGGIO ACCESSORI
4531/000

Al	5 m	12x12	€/m
----	-----	-------	-----

	∞	4505-4510-4520	
--	---	----------------	--

	o	o	o	o
--	---	---	---	---

Fe	∞	4606	€/u
----	---	------	-----

	o		
--	---	--	--

Fe	∞	4522-4512-4507	€/u
----	---	----------------	-----

	∞	4541-4542-4565	
--	---	----------------	--

	o		
--	---	--	--

MÓDULOS PARED CON COLUMNAS

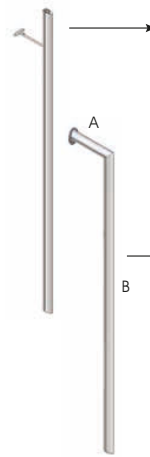

KIT PARED CON BRAZO TELESCÓPICO
KIT MUR AVEC FIXATION TÉLESCOPIQUE
KIT WALL WITH TELESCOPIC CONNECTION
KIT PARETE CON FISSAGGIO TELESCOPICO

1 columna hasta 3 m
2 cremalleras 2,5 m (4606/101)
1 tapas sup.

1 base inf.
1 brazo a pared (4545/032)
3 corte

4572/M01 4505 Milán
4572/B01 4510 Bilbo
4572/V01 4520 Verona

KIT PARED CON INGLETE
KIT MUR AVEC ONGLET
KIT MUR WITH MITRE JOINT
KIT A PARETE CON TAGLIO 45°

1 columna A+B max.=3 m
2 cremalleras 2,5 m (4606/101)
1 base inf.

1 anclaje a pared (4544)
2 escuadras (4543)
4 cortes

4573/M01 4505 Milán
4573/B01 4510 Bilbo
4573/V01 4520 Verona

GÓNDOLAS CON COLUMNAS



KIT GÓNDOLA 1º MÓDULO
KIT GONDOLA 1ERE MODULE
KIT 1ST GONDOLA MODUL
KIT GONDOLA 1º MODULO

2 columnas 1.5 mt
4 cremalleras 1.5 mt 4606/101
2 tapas
4 pies 4559/032

2 traveseros 4535/101
4 grapas 4539
8 cortes

4570/M01 4505 Milán
4570/B01 4510 Bilbo
4570/V01 4520 Verona

max.: 1,5 m - <-> 1 m



KIT GÓNDOLA 2º MÓDULO
KIT GONDOLA 2EME MODULE
KIT 1ND GONDOLA MODUL
KIT GONDOLA 2º MODULO

1 columnas 1.5 mt
2 cremalleras 1.5 mt 4606/101
1 tapas
2 pies 4559/032

2 traveseros 4535
4 grapas 4539
5 cortes

4571/M01 4505 Milán
4571/B01 4510 Bilbo
4571/V01 4520 Verona

max.: 1,5 m - <-> 1 m

ACCESORIOS TUBO OVALADO 36X18

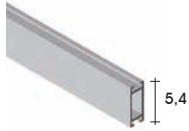

PERFIL TRAVESERO DOBLE CANAL
PROFIL TRVERSE DOUBLE FENTE
PROFILE DOUBLE SLOT
PROFILO TRAVERSA DOPPIA CANALE
*4535/1..



GALGA PARA GRAPAS 4539 Y 4540
OUTIL POUR LES MONTAGE DES JOINTS 4539 ET 4540
MOUNTING TOOL FOR THE JOINTS 4539 AND 4540
UTENSILE MONTAGGIO RACCORDI 4539 E 4540
4538/000



GRAPA UNIÓN 4535 CON COLUMNAS SIN CREMALLERA 4606
JOINT DIRECTE 4535 AVEC COLONNES SANS CRÉMAILLÈRE 4606
DIRECT JOINT 4535 WITH COLUMNS WITHOUT RACK 4606
RACCORDO DIRETTO 4535 CON COLONNE SENZA CREMAGUERA 4606
*4539/000

MONTAJE GRAPAS 4539 Y 4540 CON EL PERFIL 4535

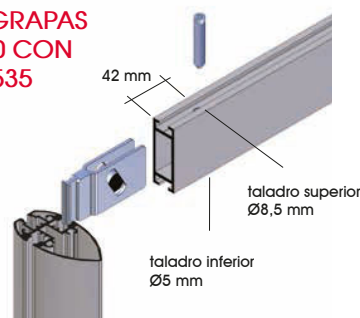

NIVELADOR SUPERIOR
VÉRIN SUPÉRIEUR
UPPER LEVEL
LIVELLATORE SUPERIORE
4541/0..

Fe	∞	4505-4510-4520	€/u



NIVELADOR INFERIOR
VÉRIN INFÉRIEUR
LOWER LEVEL
LIVELLATORE INFERIORE
4542/0..

Fe	∞	4505-4510-4520	€/u



ESCUADRA PARA INGLETE A 90°
ÉQUERRE POUR JONCTIONS 90°
FIXING JOINT 90°
SQUADRA UNIONI A 90°
4543/034

Fe	∞	4505-4510-4520	€/u



ENGANCHE A PARED
PLAQUE DE FIXATION MURALE
WALL PLATE CONNECTION
PLACA FISSAGGIO A PARETE
4544/0..

Fe	∞	4505-4510-4520	€/u

PL. M	BLANCO	NEGRO	COLOR
ALL. M	WHITE	BLACK	COULEUR
ALL. NAT.	BIANCO	NERO	COLORE
01	0B	0N	0P

Al	5 m	54x20	€/m
----	-----	-------	-----

*o	*o	*o	*o
----	----	----	----

Fe	∞	4535	€/u
----	---	------	-----

∞	4535-4505-4510-4520	Fe	€/u
---	---------------------	----	-----

*o			
----	--	--	--

COMPLEMENTOS "COLUMNS"



BRAZO PARED TELESCÓPICO
FIXATION TÉLESCOPIQUE MUR
WALL TELESCOPIC CONNECTION
FISSAGGIO TELESCOPICO A PARETE
4545/0..

CR. BRILLO	BLANCO	NEGRO	COLOR
CR. POLI	WHITE	BLACK	COULEUR
CR. ILLC.	BIANCO	NERO	COLORE
32	0B	0N	0P

Fe	∞	4505-4510-4520	€/u
----	---	----------------	-----

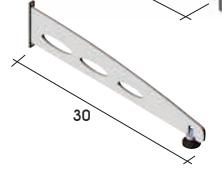

PIE GÓNDOLA O AUTOPORTANTE
PIED GONDOLA OU AUTOPORTANT
FOOT GONDOLA OR SELF-SUPPORTING
PIEDE GONDOLA O AUTOPORTANTE
4559/0.. 30 cm

Fe	∞	4505-4510-4520	€/u
----	---	----------------	-----

M8	€/u
----	-----

*o			
----	--	--	--



BASE REDONDA
BASE CIRCULAIRE
ROUND BASE
BASE CIRCOLARE
4565/0..

Fe	∞	4505-4510-4520	∅395	€/u
----	---	----------------	------	-----

*o			
----	--	--	--

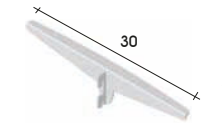

CARTELA CENTRAL
SUPPORT CROCHET CENTRAL
BRACKET WITH CENTRAL HOOK
MENSOLA INCASTRO CENTRALE
4631/0.. 30 cm

Fe	∞	4505-4510-4520+4606	€/u
----	---	---------------------	-----

--	--	--	--



SOPORTE TUBO OVAL 4547
SUPPORT TUBE PENDERIE 4547
HANGING TUBE 4547 SUPPORT
SUPPORTO TUBO APPENDERIA 4547
4546/0..

Fe	∞	4505-4510-4520+4606	€/u
----	---	---------------------	-----

∞	4547 (36x18mm)
---	----------------

--	--	--	--



TUBO OVAL 36x18 mm
TUBE OVALE 36X18 mm
OVAL TUBE 36X18 mm
TUBO OVALE 36X18 mm
4547/1..

Fe	∞	3 m	36x18x1,5	€/m
----	---	-----	-----------	-----

--	--	--	--

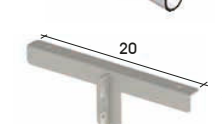

CARTELA CENTRAL
SUPPORT CROCHET CENTRAL
BRACKET WITH CENTRAL HOOK
MENSOLA INCASTRO CENTRALE
4630/0..

Fe	∞	4505-4510-4520+4606	€/u
----	---	---------------------	-----

--	--	--	--

CR. MATE	INOX	BR	BLANCO	NEGRO	COLOR
CHR. M	INOX	POLI	BLANC	NOR	COULEUR
M. CHR	P.S.S.		WHITE	BLACK	COLOR
CR. OPAC	INOX	ILLC.	BIANCO	NERO	COLORE
31	22	0B	0N	0P	



SOPORTE TUBO RECTANGULAR 4585
SUPPORT TUBE RECTANGULAIRE 4585
SUPPORT TUBE RECTANGULAIRE 4585
SUPPORTO TUBO RETTANGOLARE 4585
4634/D..
4634/Z..

Fe	∞	4585	€/u
----	---	------	-----

--	--	--	--



TUBO RECTANGULAR
TUBE RECTANGULAIRE
RECTANGULAR TUBE
TUBO RETTANGOLARE
4260/122

Fe	∞	6 m	30x10x1,4	€/m
----	---	-----	-----------	-----

--	--	--	--



PERROQUET PLANO
PENDERIE FRONTAL
STRAIGHT ARM
APPENDERIA FRONTALE
4592/0..

Fe	∞	4585	350 mm	€/u
----	---	------	--------	-----

*o			
----	--	--	--



PERROQUET INCLINADO
PERROQUET INCLINÉE
SLOPING ARM
APPENDERIA INCLINADA
4593/0..

Fe	∞	4585	400 mm	€/u
----	---	------	--------	-----

*o			
----	--	--	--

KADÍ PHARMA DUO

MEDIDAS CREMALLERAS Y MECANIZACIONES

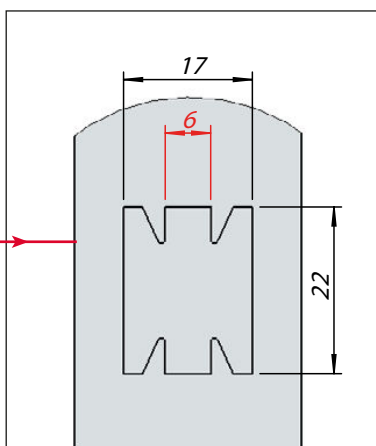
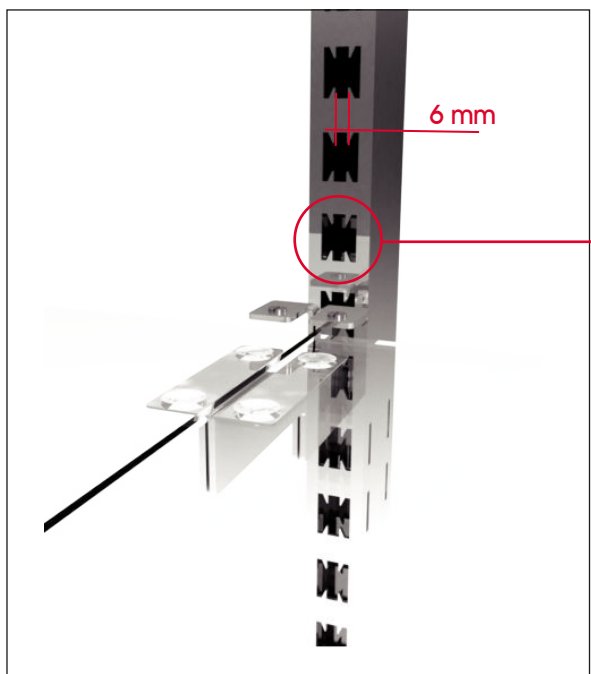

- Con un troquel más ancho.
- Posibilidad de dos cartelas en el mismo alojamiento.
- Avec une mort plus large.
- Possibilité de deux cartes dans le même perforation
- With a wider die.
- Possibility to put two brackets in the same slot.
- Con un dado più ampio.
- Possibilità di due mensole nella stessa asola.

Con la columna PHARMA DUO se pueden usar dos cartelas en un mismo troquel y poder configurar distintas alturas de estantes entre columnas.
 Avec la colonne PHARMA DUO, vous pouvez utiliser deux cartes dans la même matrice et vous pouvez configurer différentes hauteurs entre étagères entre colonnes.
 With the PHARMA DUO column you can use two brackets in the same die and configure different heights of shelves between columns.
 Con la colonna PHARMA DUO è possibile utilizzare due mensole nello stessa asola e regolare i ripiani individualmente.

SISTEMA KADÍ PHARMA DUO

CARACTERÍSTICAS DEL SISTEMA

- Compatible con la mayoría de accesorios del sistema Kadí
- Módulos de 512, 730 y 820 mm entrejes de columna
- Posibilidad de regular altura de estantes independientemente.
- Sistema modular que permite la combinación de 3 soluciones:

CARACTÉRISTIQUES DU SYSTÈME

- Compatible avec la plupart de les accessoires Kadí
- Modules de 512, 730 et 820 mm empattement colonne
- Possibilité de hauteur régulière des étagères indépendantes
- Système modulaire qui permet la combinaison de 3 solutions:

SYSTEM FEATURES

- Compatible with most Kadí system accessories
- Modules 512, 730 and 820 mm column between axes
- Possibility to adapt height of independent shelves
- Modular system that allows the combination of 3 solutions:

CARATTERISTICHE DEL SISTEMA

- Compatibile con la maggior parte degli accessori del sistema Kadí
- Moduli di 512, 730 e 820 mm fra assi dei montanti
- Possibilità di altezze regolari di mensole indipendenti
- sistema modulare che permette la combinazione di 3 soluzioni:

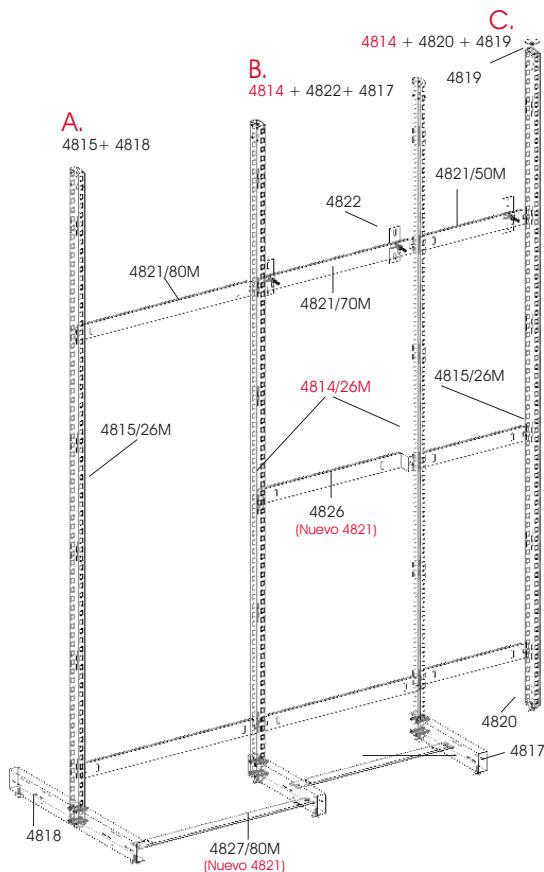

Solución
ELECTRIFICADO
Solution ELECTRIFIÉE
Solution ELECTRIFIED
Soluzione ELETRIFICATA

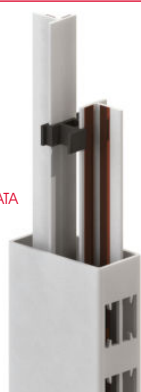

Solución GÓNDOLA ó PARED DIVISORIA

Solution GONDOLA ou PARIOL SÉPARATRICE
Solution GONDOLA or PARTITION WALL
soluzione GONDOLA o parete divisoria

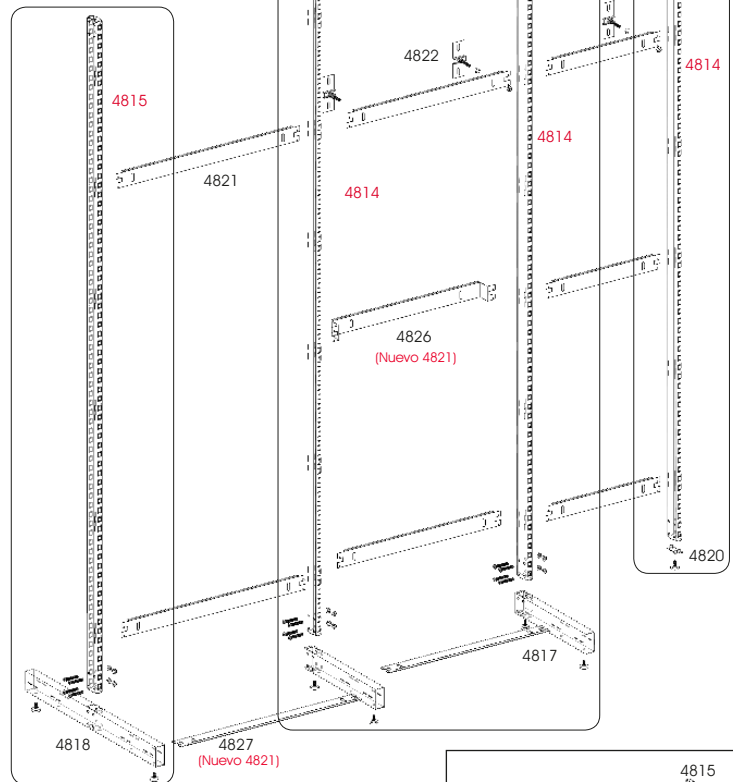

Solución GÓNDOLA

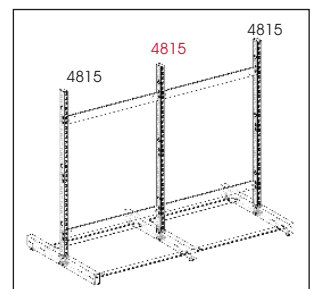
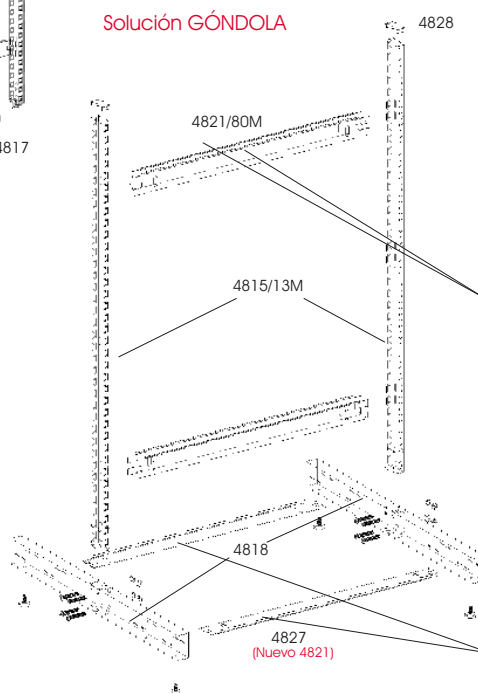

4821 TIRANTES EN PLANO DIFERENTES NUEVOS TIRANTES 4821 (APTOS PARA PIES Y MONTANTES)

El uso de tirantes de unión en planos diferentes confiere más estabilidad a la góndola.

La utilisation de tirants dans de planes différents donne plus de stabilité à la gondole

The use of rods spacer in different planes gives more stability to the gondola.

L'impiego di tiranti su piani differenti conferisce maggiore stabilità alla gondola.

4827 TIRANTE PARA PIES

El uso de tirantes de unión en planos diferentes confiere más estabilidad a la góndola.

La utilisation de tirants dans la base donne plus de stabilité à la gondole

The use of rods spacer in the base gives more stability to the gondola.

L'impiego di tiranti nella base conferisce maggiore stabilità alla gondola.

Solución TECHO-SUELO

Solution SOL-PLAFOND
Solution CEILING-FLOOR
Soluzione SUOLO-SOFFITTO

Solución PARED

Solution MUR
Solution WALL
Soluzione PARETE

CORTE DE MADERA KADÍ PAHARMA DUO

CORTE MADERA PARA UTILIZAR DOS CARTELAS PLEGADAS EN EL MISMO TROQUEL

couper du bois pour utiliser 2 supports pliés dans le même perforation
 panel cut to use 2 folded brackets in the same step
 taglio pannello per inserire 2 mensole piegate nella stessa foratura

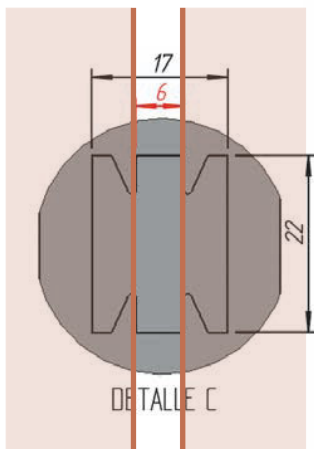
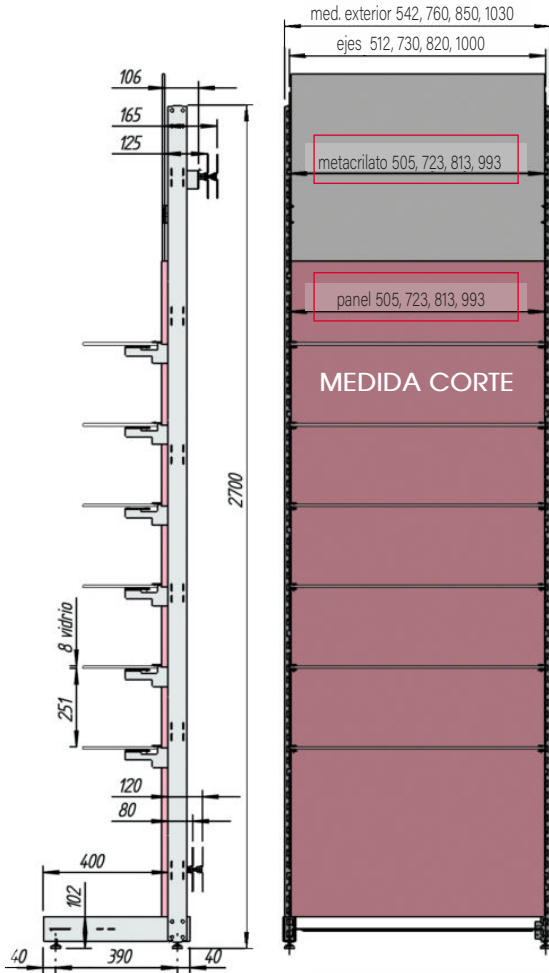

6 mm

distribuir los soportes 4823 a distancias multiples de 37 mm (1 soporte cada 90 cm aprox.)

distribute the supports 4823 at distances multiple of 37 mm (1 bracket every 90 cm approx.)
 distribuez les supports 4823 à des distances multiples de 37 mm (1 support tous les 90 cm approx.)
 distribuire i supporti 4823 a distanze multiple di 37 mm (1 supporto ogni 90 cm appross.)

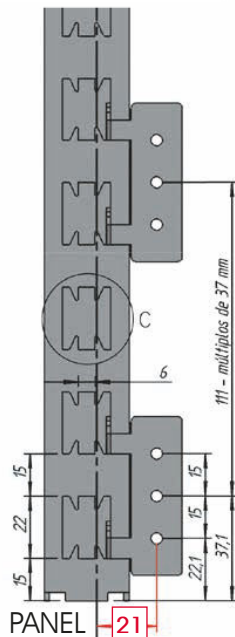

CORTE MADERA PARA UTILIZAR UNA SOLA CARTELA PLANA EN EL MISMO TROQUEL

couper du bois pour utiliser 1 support plat dans le même perforation
 panel cut to use 1 flat bracket in the same step
 taglio pannello per inserire 1 mensola piana nella stessa foratura

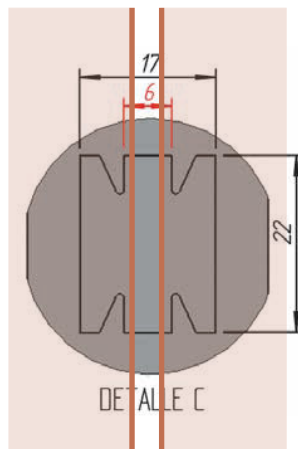
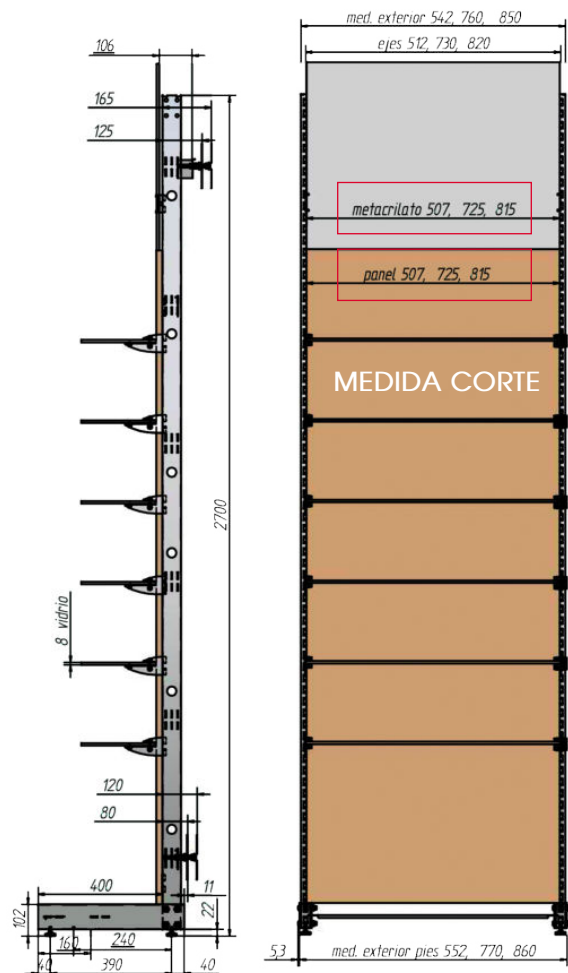

4 mm

distribuir los soportes 4823 a distancias multiples de 37 mm (1 soporte cada 90 cm aprox.)

distribute the supports 4823 at distances multiple of 37 mm (1 bracket every 90 cm approx.)
 distribuez les supports 4823 à des distances multiples de 37 mm (1 support tous les 90 cm approx.)
 distribuire i supporti 4823 a distanze multiple di 37 mm (1 supporto ogni 90 cm appross.)

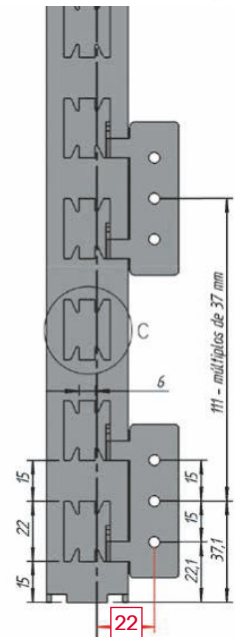

**COLUMNAS
TROQUELADAS**

GRIS 7035	BLANCO	NEGRO	COLOR
GRIS 7035	BLANC	NOIR	COULEUR
GRIS 7035	WHITE	BLACK	COLOR
GRIS 7035	BIANCO	NERO	COLOR
OM	OB	ON	OP

GRIS 7035	BLANCO	NEGRO	ZINCADO
GRIS 7035	BLANC	NOIR	PL. ZINC
GRIS 7035	WHITE	BLACK	ZINK PL.
GRIS 7035	BIANCO	NERO	ZINCATO
OM	OB	ON	34

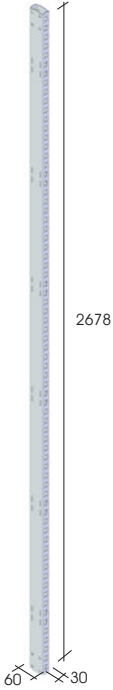

COLUMNA TROQUELADA 2 CARAS
COLONNE PERFORATION SIMPLE 2 CÔTÉS
UPRIGHT SINGLE SLOT CHANNEL 2 SIDES
PIANTANA PERFORAZIONE SINGOLA 2 LATI
4815/26B 2678 mm



Fe	60x30x2 mm	€/u
----	------------	-----

○



COLUMNA TROQUELADA 1 CARA
COLONNE PERFORATION SIMPLE 1 CÔTÉ
UPRIGHT SINGLE SLOT CHANNEL 1 SIDE
TUBO PERFORAZIONE SEMPLICE 1 LATO
4814/26B 2678 mm

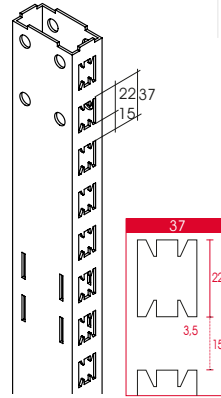

Fe	60x30x2 mm	€/u
----	------------	-----

○

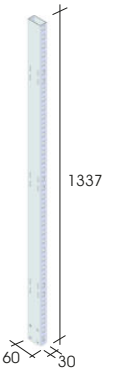

COLUMNA TROQUELADA 2 CARAS
COLONNE PERFORATION SIMPLE 2 CÔTÉS
UPRIGHT SINGLE SLOT CHANNEL 2 SIDES
PIANTANA PERFORAZIONE SINGOLA 2 LATI
4815/13B 1337 mm

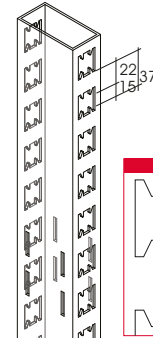

Fe	60x30x2 mm	€/u
----	------------	-----

○

ZINCADO
PL. ZINC
ZINK PL.
ZINCATO
34

Fe	∞ 4814-4815	€/u
----	-------------	-----

○



ANCLAJES PANELES MADERA
CROCHET PANNEAUX EN BOIS
HOOK WOOD PANELS
GANCIO PER PANNELLI IN LEGNO
4823/034

ANCLAJES METACRILATO Y VIDRIO
SUPPORT MÉTHACRYLATE ET VERRE
METHACRYLATE AND GLASS SUPPORT
SUPPORTO PER PLEXIGLAS E VETRO
4824/034

Fe	max. 8 mm	€/u
----	-----------	-----

○

	GRUESOS PANELES		
	10 mm	16 mm	19 mm
4645-4646	S	N	N
4620-4621	S	N	N
4622-4623	S	N	N
4626	S	N	N
4652-4653	S	S	S
4654-4655	S	N	N
4656-4657	S	N	N
4705	N	N	N
4706	N	N	N
4708	N	N	N
4715-4716	S	S	S
4717	S	S	S
4730	N	N	N
4731	N	N	N
4732	S	N	N
4733	S	S	S
serie TUBULARES	N	N	N
4618	S	S	S
4619	S	S	S
4680	S	S	S
4681	S	S	S
4682	S	S	S
4683	S	S	S
4684	S	S	S
4695	S	S	S
4696	S	S	S
4691-4692	S	S	S
4693-4694	S	S	S
4844-4845	S	S	S
4846-4847	S	S	S
5844	S	S	S
5845	S	S	S
5846	S	S	S

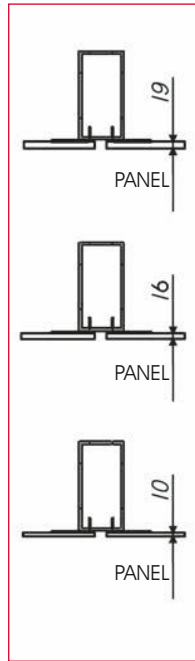

○ Utilizar las cartelas con panel adecuado.
Utilisez le supports avec un panneau approprié.
USE the adequated bracket for the thickness panel
Utilizzare la mensola con pannello idoneo.

COMPONENTES

	GRIS 7035 GRIS 7035 GRAY 7035 GRIGIO 7035	BLANCO BLANC WHITE BIANCO	NEGRO NOIR BLACK NERO	COLOR COULEUR COLOR COLORE	OM	OB	ON	OP
<p>NIVELADOR INCLUIDO VÉRIN INCLUS LEVEL INCLUDED LIVELLATORE INCLUSO</p> <p>PIE AUTOPORTANTE A PARED PIED AUTOPORTANT MUR SELF-SUPPORTING FOOT BASE AUTOPORTANTE A PARETE 4817/00B</p>	Fe	80x40x2 mm	€/u					
<p>NIVELADOR INCLUIDO VÉRIN INCLUS LEVEL INCLUDED LIVELLATORE INCLUSO</p> <p>PIE AUTOPORTANTE GÓNDOLA PIED GONDOLA GONDOLA FOOT BASE GONDOLA 4818/00B</p>	Fe	80x40x2 mm	€/u					
<p>ANCLAJE TECHO-SUELO VÉRIN SUPÉRIEUR UPPER LEVEL LIVELLATORE SUPERIORE 4819/00B</p>	Fe	60x30x3 mm M8	€/u					
<p>BASE COLUMNA VÉRIN INFÉRIEUR LOWER LEVEL LIVELLATORE INFÉRIORE 4820/00B</p>	Fe	60x30x3 mm M8	€/u					
<p>KIT DE Z CON RUEDA DE ALTA RESISTENCIA KIT Z AVEC ROUE ROBUSTE Z KIT WITH HEAVY DUTY WHEEL Z KIT CON RUOTA PER SERVIZIO PESANTE 4818/ROB</p>	Fe	40kg	M10	€/u				
<p>MISMO TIRANTE PARA MONTANTES Y PIES</p> <p>TIRANTES DISTANCIADORES TIRANT-ESPACEMENT ROD-SPACER TIRANTE-DISTANZIATORE 4821/50B eje 512 mm 4821/60B eje 670 mm 4821/70B eje 730 mm 4821/80B eje 820 mm 4821/10B eje 1000 mm</p>	Fe	€/u						
<p>EJAJCIÓN TIRANTES A PARED PATTES DE FIXATION ROD-SPACER WALL SUPPORT FISSAGIO TIRANTI A PARED 4822/00B</p>	Fe	€/u						
<p>TIRANTE (ILUMINACIÓN) TIRANT-ESPACEMENT (ÉCLAIRAGE) ROD-SPACER (LIGHTING) TIRANTE (ILLUMINAZIONE) *4826/70B eje 730 mm *4826/80B eje 820 mm</p>	Fe	€/u						
<p>TIRANTE ENTRE PIES TIRANT-ESPACEMENT ENTRE LE PIED ROD-SPACER BETWEEN FEET TIRANTE FRA BASI MONTANTI *4827/50B eje 512 mm *4827/70B eje 730 mm</p>	Fe	€/u						
<p>TIRANTES TELESCÓPICO TIRANT TELESCOPIQUE TELESCOPIC ROD-SPACER TIRANTE TELESCOPICO módulo 100 cm módulo 90 cm telescópico entre 54,5 y 100 cm 4840/00B</p>	Fe	54,5 <-> 100 cm	€/u					

	CR. BRILLO CHR. POLI BR. CHR. CR. ILLUC.	BLANCO BLANC WHITE BIANCO	NEGRO NOIR BLACK NERO	ZINCADO PL. ZINK PL. ZINCATO	32	OB	ON	34
<p>BARRA SOPORTE GANCHOS SUPPORT CROCHETS SUPPORT HOOKS BARRA SUPPORTO GANCI 4829/7D. eje 730 mm 4829/8D. eje 820 mm 4829/1D. eje 1000 mm</p>					Fe	€/u		
<p>GANCHO CROCHET HOOK BARRETTA 445/X.. 20 cm GANCHO PORTAPRECIO CROCHET PORTAPRIX HOOK LABEL-HOLDER BARRETTA PORTAPREZZO 447/X.. 20 cm</p>					Fe	€/u		
<p>PORTAPRECIO PORTAPRIX LABELHOLDER PORTAPREZZO 382/009</p>					plac	40x50 mm	€/u	
<p>CARTELA PARA COLGAR MUEBLES SUPPORT POUR MOBILE FURNITURE BRACKET MESNOLA PER MOBILI 4733/032</p>					Fe	€/u		
<p>EMPALMADOR COLUMNA JOINT COLONNES COLUMNS JOINT GIUNZIONE PIANTANE 4825/00B</p>					Fe	M10	€/u	
<p>TAPA COLUMNA BOUCHON END-CAP UPRIGHT COPRITESTA PIANTANA 4828/00B</p>					Fe	60x30 mm	€/u	

CARTELA FINAL BARRA ACCESORIOS (36X18)

	CR. BRILLO CHR. POLI BR. CHR. CR. ILLUC.	CR. MATE CHR. M M. CHR. CR. OPAC	BLANCO BLANC WHITE BIANCO	NEGRO NOIR BLACK NERO	COLOR COULEUR COLOR COLORE	32	31	OB	ON	OP
<p>CARTELA BARRA ACCESORIOS SUPPORTI BARRE ACCESSORIES BRACKET FOR ACCESSORIES ROD MENSOLA TUBO PORTA-ACCESSORI 4716/0.. derecha droite/right/destra 4717/0.. izquierda gauche/left/sinistra</p>	Fe	60mm	∞ 4547 (36x18)	€/u						
<p>CARTELA BARRA ACCESORIOS SUPPORTI BARRE ACCESSORIES BRACKET FOR ACCESSORIES ROD MENSOLA TUBO PORTA-ACCESSORI 4715/0.. intermedia inter./inter./inter.</p>	Fe	60mm	∞ 4547 (36x18)	€/u						

TUBO OVALADO 36X18

<p>TUBO OVAL 36x18 mm TUBE OVALE 36X18 mm OVAL TUBE 36X18 mm TUBO OVALE 36X18 mm 4547/1..</p>	Fe	3 m	36x18x1,5	€/m					
<p>GANCHO PORTAPRECIO CROCHET PORTAPRIX HOOK LABEL-HOLDER BARRETTA PORTAPREZZO 3012/0.. 25 cm</p>	Fe	∞ 4547-382	€/u						
<p>PORTAPRECIO PORTAPRIX LABELHOLDER PORTAPREZZO 382/009</p>	plac	40x50 mm	€/u						

PLÁSTICO
PLASTIQUE
PLASTIC
PLASTICA
09

KADÍ PHARMA



SE RECOMIENDA ESTANTE DE VIDRIO TEMPLADO DE 30CM DE PROFUNDIDAD

CARTELA FINAL ANTIVUELCO
SUPPORT FINAL ANTIBASCULAMENT
FINAL BRACKET ANTITIPPING
MENSOLA FINALE ANTIRIBALTAMENTO
*4618/3..



SE RECOMIENDA ESTANTE DE VIDRIO TEMPLADO DE 30CM DE PROFUNDIDAD

CARTELA INTERMEDIA ANTIVUELCO
SUPPORT INTERMÉDIAIRE ANTIBASCULAMENT
INTERMEDIATE BRACKET ANTITIPPING
MENSOLA INTERMEDIA ANTIRIBALTAMENTO
*4619/3..

CARTELA "SILUETTE"

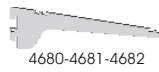

4680-4681-4682

CARTELA SUPPORT BRACKET MENSOLA



4683-4684

4680/0.. 14cm
4681/0.. 23cm
4682/0.. 28cm
4683/0.. 33cm
4684/0.. 38cm

CARTELA "SILUETTE" INCLINADA



CARTELA INCLINADA 30°
SUPPORT INCLINÉE 30°
SLOPING BRACKET 30°
MENSOLA INCLINATA 30°
4696/0.. 32cm

CABALLETES ESTANTES PARA CARTELAS



ALETA FINAL CAVALIER FINAL FINAL SADDLES CAVALIERE FINALE
4700/0..



ALETA INTERMEDIA CAVALIER DOUBLE BOUBLE SADDLES CAVALIERE DOPPIO
4701/0..



APOYO APPUI SUPPORT APPOGGIO
4702/009



VENTOSA VENTOUSE SUCTION VENTOSA
319/009



VENTOSA VENTOUSE SUCTION VENTOSA
2556/009

ESTANTES DE VIDRIO 8 mm support verre 8 mm recommandée recommended 8mm glass bracket mensola per vetro 8 mm consigliata



ESTANTES DE MADERA O VIDRIO supports verre/bois recommandée recommended glass/wood brackets mensola per vetro/legno consigliata

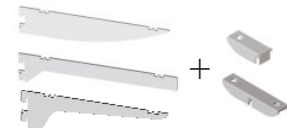

La profundidad de estante recomendado para las cartelas suspendidas de la gama "CARTELAS ESPECIALES VIDRIO" es de 25-30 cm max. La profundidad del estante interfiere directamente en la capacidad y resistencia de aguante de las mismas cartelas y de todo el sistema.

CR. BRILLO	INOX SAT	BLANCO	NEGRO	COLOR
CR. POLI	S.S.S.	WHITE	BLACK	COULEUR
BR. CHR.	INOX SAT	BIANCO	NERO	COLOR
CR. ILLC.		BIANCO	NERO	COLORE
32	28	0B	0N	0P

KADÍ PHARMA

DUO

CARTELAS ESPECIALES PARA PHARMA, CREMALLERA DUO Y ELECTRIFICADO. (APTO PARA TODOS LOS SISTEMAS KADÍ)



CARTELA SUPPORT BRACKET MENSOLA



5844/... derecha droite/right/destra
5845/... izquierda gauche/left/sinistra



5846/... doble double/double/doppio



CARTELA DERECHA SUPPORT DROITE RIGHT BRACKET MENSOLA DESTRA
*4844/0..

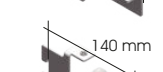

CARTELA IZQUIERDA SUPPORT GAUCHE LEFT BRACKET MENSOLA SINISTRA
*4845/0..

"SILUETTE" PLEGADA



CARTELA SUPPORT BRACKET MENSOLA



4692/0.. derecha droite/right/destra
4691/0.. izquierda gauche/left/sinistra



4694/0.. derecha droite/right/destra
4693/0.. izquierda gauche/left/sinistra

CARTELAS "GRANDES PESOS"



CARTELA GRANDES PESOS SUPPORT GRAN POID BRACKET HEAVY WEIGHT MENSOLA GRANDI PESI
4652/0.. derecha droite/right/destra
4653/0.. izquierda gauche/left/sinistra



CARTELA INCLINADA 30° SUPPORT INCLINÉE 30° SLOPING BRACKET 30° MENSOLA INCLINATA 30°
4632/0.. derecha droite/right/destra
4633/0.. izquierda gauche/left/sinistra



CARTELA ESTANTE MADERA SUPPORT TABLETTES BOIS WOOD SHELF BRACKET MENSOLA RIPIANO LEGNO



4676/0.. derecha droite/right/destra
4675/0.. izquierda gauche/left/sinistra



350

CR. BRILLO	INOX SAT	BLANCO	NEGRO	COLOR
CR. POLI	S.S.S.	WHITE	BLACK	COULEUR
BR. CHR.	INOX SAT	BIANCO	NERO	COLOR
CR. ILLC.		BIANCO	NERO	COLORE
32	31	0B	0N	0P

MULTILAMA



ANCLAJE MULTILAMA A TIRANTE 4821
FIXATION MULTILAMA-TIRANT 4821
MULTILAMA-ROD SPACER 4821 JOINT
AGGANGIO MULTILAMA-TIRANTE 4821
4838/000

MULTILAMA ALUMINIO
REGATA CADA 12,5



MULTILAMA ALUMINIO
12 CANALES (12,5 MM)
PROFIL LAME D'ALUMINIUM
12 rainures chaque 12,5 mm
ALUMINIUM SLATWALL PROFILE
12 Slots every 12,5 mm
PROFLO DOGATO ALLUMINIO
12 ranure ogni 12,5 mm
401/1..

Altura de la multilama 152 mm

GUÍA PARED MULTILAMA



CREMALLERA PARED
PARA PERFILES 401, 403
CRÉMAILLÈRE MUR
Avec profils 403 et 401
WALL RACK
for profiles 403 y 401
CREMAGLIERA PARETE
con profili 403 e 401
400/334

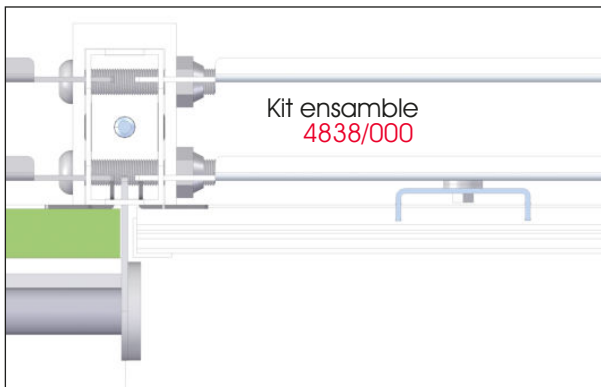

Kit ensamble
4838/000

GRIS 7035	BLANCO	NEGRO	CR. BRILLO
GRIS 7035	BLANCO	NOR	CR. POLI
GRIS 7035	WHITE	BLACK	CR. CHR
GRIS 7035	BIANCO	NERO	CR. ILLC.
OM	OB	ON	32
			inox
			€/u
			o
BLANCO	NEGRO	COLOR	PL. M
BLANC	NOR	COULEUR	ALU. M
WHITE	BLACK	COLOR	ALU. M
BIANCO	NERO	COLORE	ALL. NAT
OB	ON	OP	O1
Al	5 m	∞	400
			€/m
			o
			o
			o
			o
			ZINCADO
			PL. ZINK
			PL. ZINCATO
			34
Al	3 m	∞	401-403
			€/m
			o

PHARMA+MULTILAMA

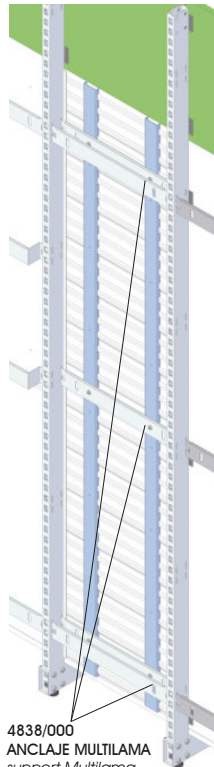

Solución con MULTILAMA
Solution avec MULTILAMA
Solution with MULTILAMA
Soluzione con MULTILAMA



MONTAJE FRONTAL
montage frontal
front mounting
montaggio frontale

1650/1..
REMATE ÁNGULO 15X15
profil lateral de finition
lateral finishing profile
profilo laterale di finitura

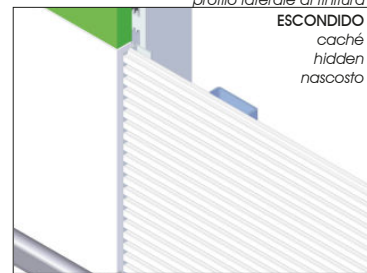

1651/1..
REMATE ÁNGULO 20X20
profil lateral de finition
lateral finishing profile
profilo laterale di finitura

ESCONDIDO
caché
hidden
nascosto

4838/000
ANCLAJE MULTILAMA
support Multilama
support Multilama
supporto Multilama

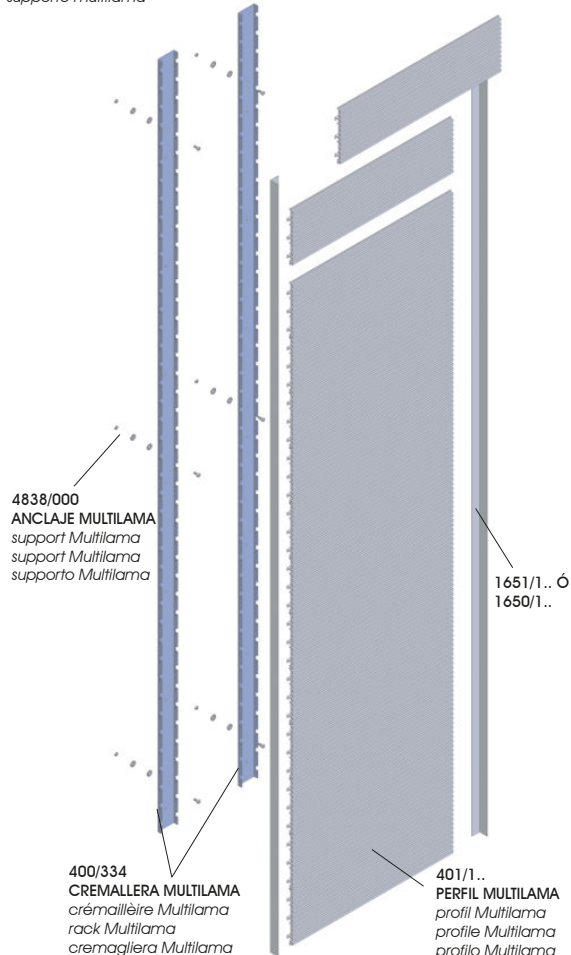

4838/000
ANCLAJE MULTILAMA
support Multilama
support Multilama
supporto Multilama

1651/1.. Ó
1650/1..

400/334
CREMALLERA MULTILAMA
crémaillère Multilama
rack Multilama
cremagliera Multilama

401/1..
PERFIL MULTILAMA
profil Multilama
profile Multilama
profilo Multilama

SEPARADORES Y PORTAPRECIOS

SEPARADORES CON DISPENSADOR DE PRODUCTO

SÉPARATEURS ET PUSSEURS
DEVIDERS AND PUSHERS
SEPARATORI E PUSHERS



SEPARADOR FINAL IZQUIERDA
ESTANTE 30 cm
SÉPARATEUR EXTRÉMITÉ GAUCHE
TABLETTE 30 cm
LEFT SIDE SHELF DIVIDER SHELF 30cm
SEPARATORE ESTREMITÀ SINISTRA
RIPIANO 30 cm
4833/009 transp.

plas 285mm €/u



SEPARADOR FINAL DERECHA
ESTANTE 30 cm
SÉPARATEUR EXTRÉMITÉ DROITE
TABLETTE 30 cm
RIGHT SIDE SHELF DIVIDER SHELF 30cm
SEPARATORE ESTREMITÀ DESTRA
RIPIANO 30 cm
4834/009 transp.

plas 285mm €/u



SEPARADOR INTERMEDIO
ESTANTE 30 cm
SÉPARATEUR CENTRAL TABLETTE 30cm
CENTRE SHELF DIVIDER SHELF 30 cm
SEPARATORE CENTRALE
RIPIANO 30cm
4835/009 transp.

plas 285mm €/u

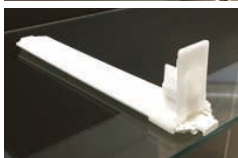

DISPENSADOR CON MUELLE
ESTANTE 30 cm
DISTRIBUTEUR À PRESSION DE
PRODUIT TABLETTE 30 cm
PUSHER SHELF 30 cm
DISTRIButore A PRESSIONE
RIPIANO 30 cm
4836/009

plas 285mm €/u

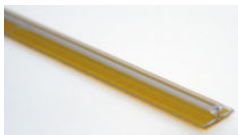

GUÍA POSTERIOR ADHESIVA
GUIDE DERRIÈRE ADHÉSIF
ADESIVE BACK GUIDE
GUIDA POSTERIORE ADESIVA
4832/109 transp.

plas 39 mm €/m

plas 1m

plas 1m

plas 1m

plas 1m

plas 1m

plas 1m

plas 1m

plas 1m

plas 1m

plas 1m

plas 1m

plas 1m

plas 1m

plas 1m

plas 1m

plas 1m

plas 1m

plas 1m

plas 1m

plas 1m

plas 1m

PORTAPRECIOS PARA VIDRIO Y MADERA

TITULAIRE DE PRIX POUR VERRE ET BOIS
PRICE HOLDER FOR GLASS AND WOOD
DETENTORE DEL PREZZO PER VETRO E LEGNO

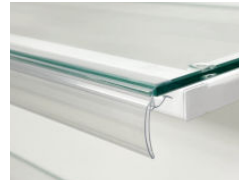

GUÍA FRONTAL ESTANTE DE VIDRIO
GUIDE FRONTAL ÉTAGÈRE EN VERRE
FRONT GLASS SHELF GUIDE
GUIDA FRONTALE RIPIANO IN VETRO
4830/109 transp.

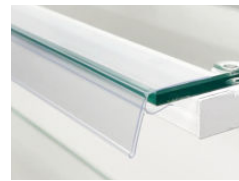

GUÍA FRONTAL ESTANTE DE VIDRIO
GUIDE FRONTAL ÉTAGÈRE EN VERRE
FRONT GLASS SHELF GUIDE
GUIDA FRONTALE RIPIANO IN VETRO
4837/109 transp.



GUÍA FRONTAL ESTANTE DE VIDRIO
GUIDE FRONTAL ÉTAGÈRE EN VERRE
FRONT GLASS SHELF GUIDE
GUIDA FRONTALE RIPIANO IN VETRO
4848/109 transp.

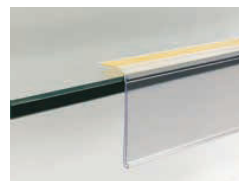

GUÍA FRONTAL ESTANTE DE VIDRIO / MADERA
GUIDE FRONTAL ÉTAGÈRE EN VERRE / BOIS
FRONT GLASS / WOOD SHELF GUIDE
GUIDA FRONTALE RIPIANO IN VETRO / LEGNO
4849/109 transp.



GUÍA FRONTAL ADHESIVA ESTANTE DE MADERA
GUIDE FRONTAL ADHÉSIF ÉTAGÈRE EN BOIS
ADHESIVE FRONT WOOD SHELF GUIDE
GUIDA FRONTALE ADESIVA RIPIANO IN LEGNO
PLÁSTICO TRANSPARENTE
4831/109 transp.

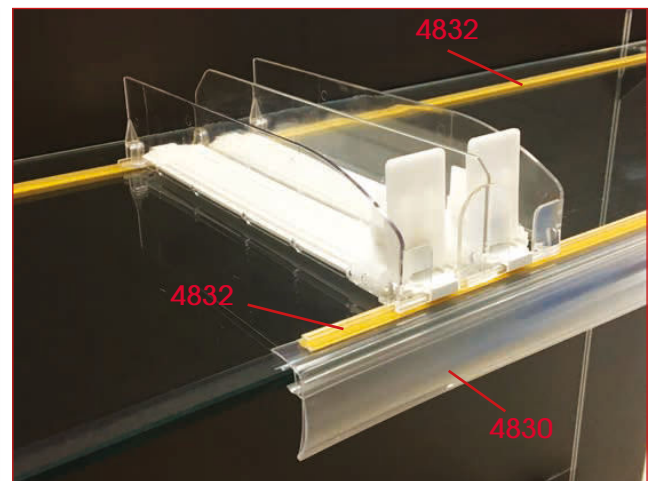
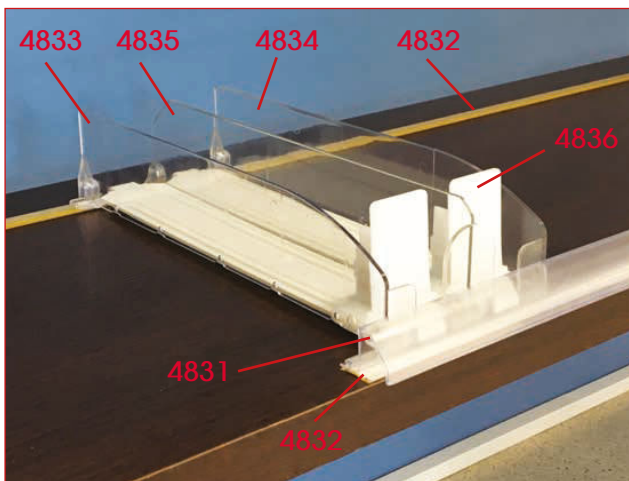

KADÍ PRIMO 25X25

TUBO TROQUELADO 25X25MM

KADÍ PRIMO es un sistema modular para crear todo tipo de muebles en tubo de hierro 25x25 mm.
Sistema compatible con cartelas y accesorios Kadí.

Kadí Primo est un système modulaire pour créer toutes sortes de meubles en tubes 25x25 mm.
Système compatible avec les supports et accessoires Kadí.

Kadí Primo is a modular system to create all kinds of furniture in iron 25x25 mm tube.
System compatible with Kadí brackets and accessories.

KADÍ PRIMO è un sistema modulare per creare tutti i tipi di mobili in tubo di ferro 25x25 mm.
Sistema compatibile con mensole e accessori Kadí.



KADÍ PRIMO

SISTEMA KADÍ-PRIMO: COMPATIBLE
CON ACCESORIOS SISTEMA KADÍ

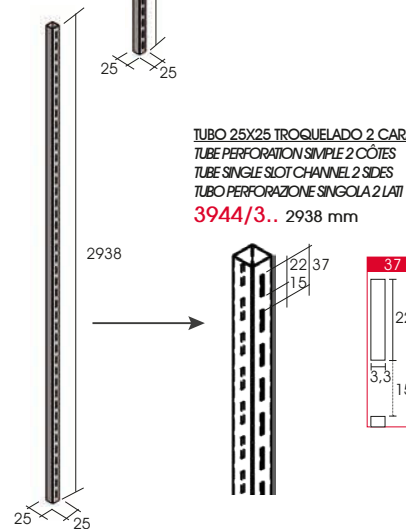
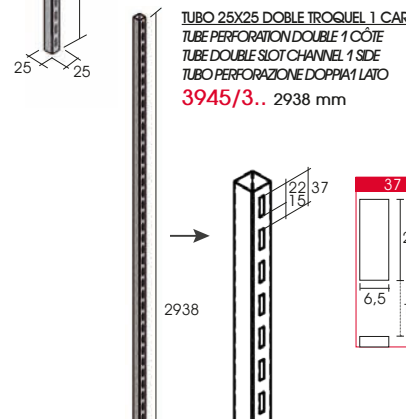
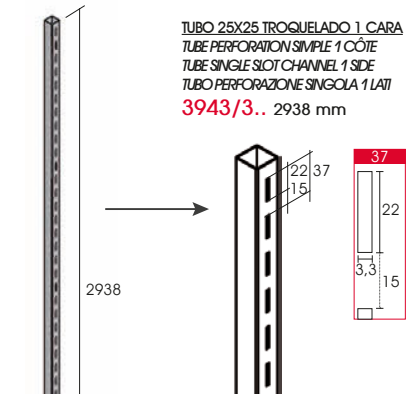

BLANCO	NEGRO	COLOR
BLANC	NOIR	COULEUR
WHITE	BLACK	COLOR
BIANCO	NERO	COLOR
OB	ON	OP

25x25x1,2 mm	Fe	€/u
--------------	----	-----

25x25x1,2 mm	Fe	€/u
--------------	----	-----

25x25x1,2 mm	Fe	€/u
--------------	----	-----

Fe	€/u
----	-----

EJEMPLOS DE MONTAJE PRIMO

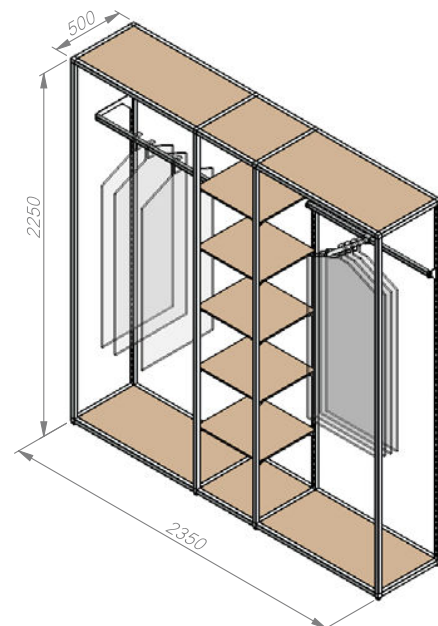
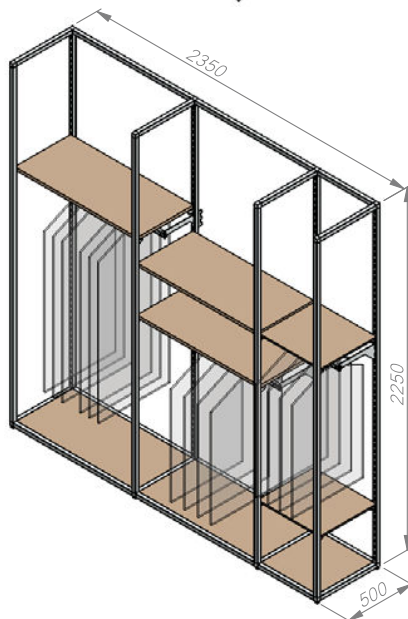
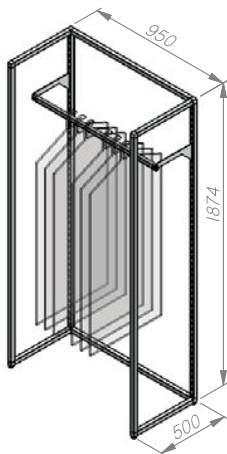
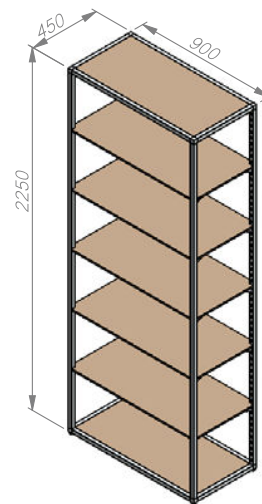
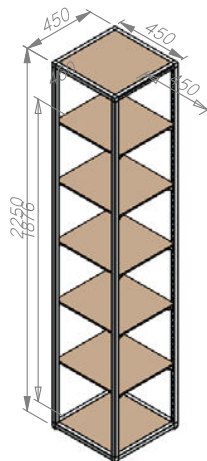
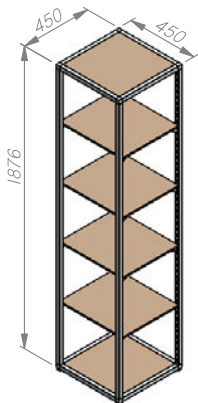
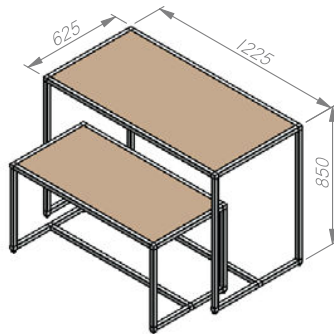
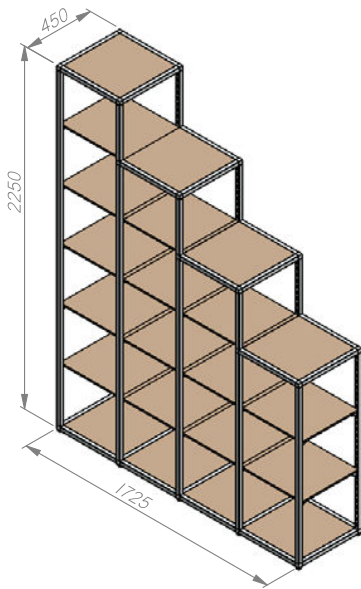

EJEMPLOS DE MONTAJE NUDOS BRIDA

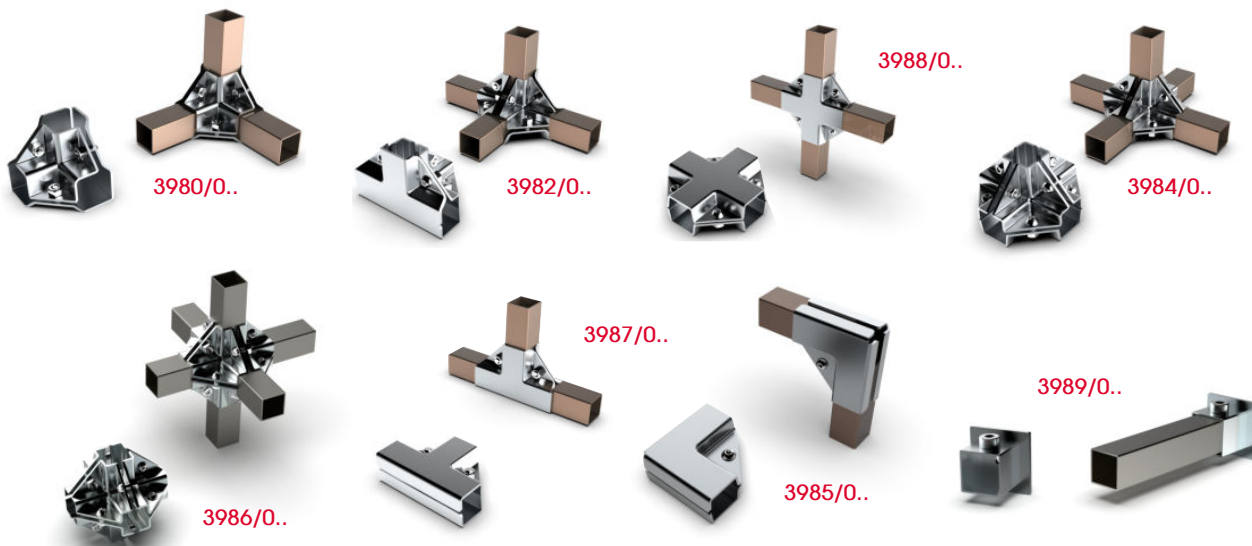

TUBO 25X25







instal.

LAMAS

SISTEMAS SIN ILUMINACIÓN

SISTEMA LAMAS

PANELES Y PERFILES

SISTEMA LAMAS 361
COMPONENTES

LAMAS - CASQUILLO

LAMAS - "INVISIBLE" 403

LAMAS - DM

LAMAS - ALUMINIO

ACCESORIOS LAMAS
ACCESORIOS HIERRO
ACCESORIOS ALUMINIO
ACCESORIOS PLÁSTICO

PARALELO 384
ACCESORIOS

PERFIL PARALELO MAXI 389

OPTI 3
INFORMACIÓN TÉCNICA

SISTEMA LAMAS



Accesorios para perfil invisible 361

Accessoires pour le profil INVISIBLE 361

Fittings for the INVISIBLE profile 361

Accessori per il Profilo INVISIBLE 361

PANELES Y PERFILES

PANNEAUX ET PROFILS / PANELS AND PROFILES / PANNELLI E PROFILI

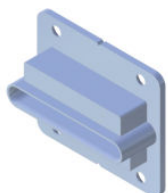

Casquillo LAMAS
ref. 359

Insert LAMAS
LAMAS socket
Boccola LAMAS



Lamas INVISIBLE
ref. 361

Profil INVISIBLE
INVISIBLE profile
Profilo INVISIBLE

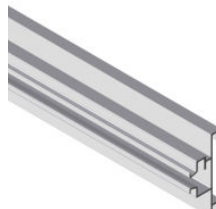

Lamas INVISIBLE+cremallera
ref. 403 + ref. 400

Profil INVISIBLE + crémaillère
INVISIBLE profile + rack
Profilo INVISIBLE + cremagliera

COMPATIBLES CON:

COMPATIBLE AVEC :

COMPATIBLE WITH:

COMPATIBLE CON:

STOCK ALU SYSTEM

1. accesorios hierro
accessoires en fer, iron fittings, accessori di ferro
2. accesorrios aluminio
accessoires aluminium, aluminium fittings,
accessori alluminio
3. accesorios plástico
accessoires plastique, plastic fittings, accessori
plastica

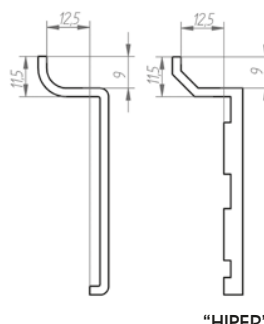
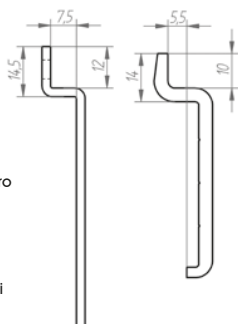

COMPATIBLES CON:

COMPATIBLE AVEC :

COMPATIBLE WITH:

COMPATIBLE CON:

accesorios "HIPER"

(no stock)

accessoires "HIPER",
"HIPER" fittings, accessori "HIPER"

"HIPER"



Lamas "DM" ref. 477-432

Panneau rainuré MDF avec profils
slatwall panel MDF with profiles
Pannello dogado MDF con profili

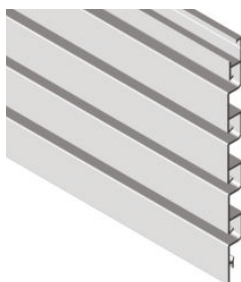

Lama aluminio ref. 429

Profil LAME D'ALUMINIUM
ALUMINIUM SLATWALL profile
Profilo DOGATO DI ALLUMINIO

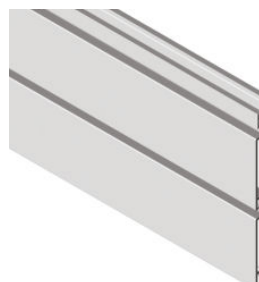

Lama aluminio ref. 427

Profil LAME D'ALUMINIUM
ALUMINIUM SLATWALL profile
Profilo DOGATO DI ALLUMINIO



Perfil para "DM" ref. 450

Profil d'aluminium x panneau rainuré
aluminium profile x slatwall panel
Profilo di alluminio x pannello dogato

COMPATIBLES CON:

COMPATIBLE AVEC :

COMPATIBLE WITH:

COMPATIBLE CON:

STOCK ALU SYSTEM

1. accesorios hierro
accessoires en fer, iron fittings, accessori di ferro
- ⊗ 2. accesorrios aluminio
accessoires aluminium, aluminium fittings,
accessori alluminio
3. accesorios plástico
accessoires plastique, plastic fittings, accessori
plastica

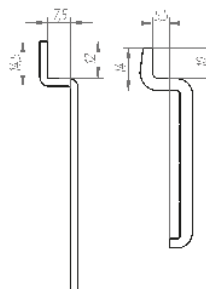

SISTEMA LAMAS 361

LAMA DE ALUMINIO INVISIBLE 361

- Admite estante de vidrio de 6 y 8 mm SE RECOMIENDA VIDRIO DE SEGURIDAD
- Sistema machihembrado
- Peso max. admitido según tipo de montaje: Estante vidrio 8 mm: 50 kg/ml / Estante vidrio 6 mm: 25 kg/ml
- Accesorios: 20 kg/u. ó peso max. admitido por cada accesorio (si inferior a 20 kg)
- Admite iluminación LED en el canal del perfil
- Compatibles con accesorios estándar de Lamas (admite accesorios tipo "Hiper") y accesorios especiales 361

LAMA aluminium INVISIBLE 361

- Permet étagère en verre de 6 et 8 mm d'épaisseur
- Verre de sécurité est recommandé
- montage panneau à emboîtement
- Max. poids admis en fonction du type de montage:
- Étagère en verre de 8mm: 50 kg / ml
- Étagère en verre de 6mm: 6 mm 25 kg / ml
- Accessoires: 20 kg / u. ou poids max. approprié pour chaque accessoire (si moins de 20 kg)
- Permet l'éclairage LED
- Compatible avec les accessoires standards (Lamas et raccords spéciaux tels que "Hiper") et accessoires spéciaux 361

LAMA aluminium INVISIBLE 361

- Allows glass shelf 6 and 8 mm thick
- Safety glass is recommended
- Socket joint or panel fitting from behind
- Max. admitted weight depending on assembly type:
- 8 mm glass shelf: 50 kg / ml
- 6 mm glass shelf: 25 kg / ml
- Accessories: 20 kg / u. weight or max. suitable for each accessory (if less than 20 kg)
- Allows LED lighting
- Compatible with standard accessories Lamas (and special fittings such as "Hiper") and special fittings 361 series

LAMA alluminio INVISIBLE 361

- ammette ripiani in vetro di 6 e 8 mm
- Si raccomanda l'uso di vetro sicurizzato
- Sistema incastro
- Peso massimo ammesso a seconda del tipo di montaggio:
- Ripiano di vetro 8 mm: 50 kg/ml
- Ripiano di vetro 6 mm: 25 kg/ml
- Accessori: 20 kg/u. o peso massimo ammesso per cadauno (se inferiore a 20 kg).
- Ammette LEDs
- Compatibile con accessori standard Lamas (e accessori speciali tipo "Hiper") e accessori speciali 361



MONTAJE A PARED

Montaje mural / Wall mounting / Montaggio a parete

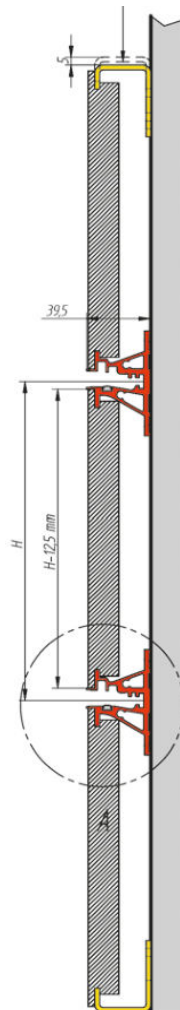
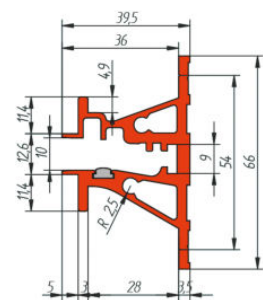
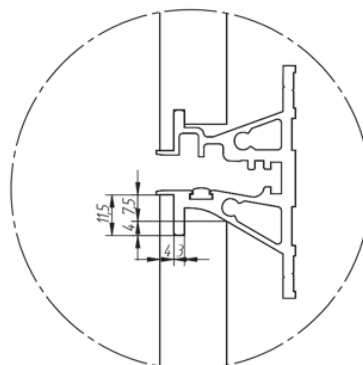

COMPONENTES

LAMAS "INVISIBLE"

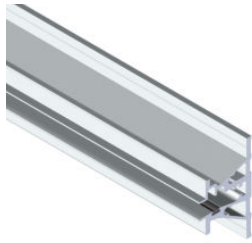

LAMA ALUMINIO
PROFIL D'ALUMINIUM
ALUMINIUM PROFILE
PROFILO DI ALLUMINIO

Al	5 m	6/8 mm	€/m
----	-----	--------	-----

COMPATIBLE CON:
ACC. ESTÁNDAR LAMAS
ACC. ESPECIALES HIPER.
ACC. 361
361/1..

OB	ON	OP	01
○	○	○	○

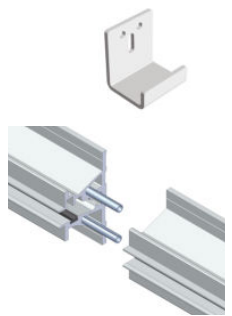

SOPORTE PANEL
INFERIOR/SUPERIOR
SUPPORT BOIS
INFÉRIEUR / SUPÉRIEUR
WOOD SUPPORT LOWER / UPPER
SUPPORTO PANNELLO LEGNO
INFERIORE / SUPERIORE
370/00B

Fe	45x35x40	€/u
----	----------	-----

PASADOR UNIÓN PERFILES Ø5 mm
BROUCHE À RESSORT Ø 5 mm
BOLT JOINING PROFILES Ø 5 mm
PERNO A MOLLA Ø 5 mm
358/000

Fe	600x380 mm	€/u
∞	361	€/u

Estantes
de vidrio
se recomienda
vidrio templado

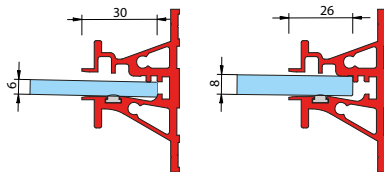

Accesorios LAMAS Accesorios HIPER Accesorios 361

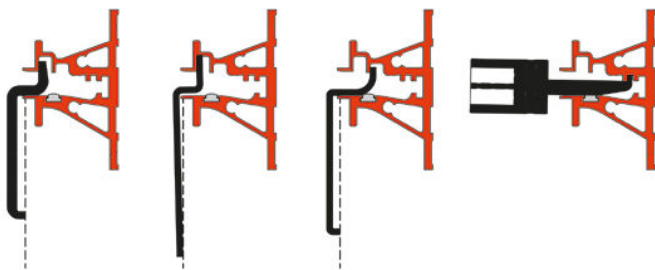

ACCESORIOS



SUPPORTO ACCESSORIOS
SUPPORT ACCESSOIRES
ACCESSORIES SUPPORT
SUPPORTO ACCESSORI
300/031

CR. BRILLO CHR. POLI BR. CHR CR. LUC.	CR. MATE CHR. M M. CHR CR. OPAC	COLOR COULEUR COLOR COLORE
32	31	0P

para tubo Ø25x1,5 mm
inox
s.s. €/u



CARTELA
SUPPORT
BRACKET
MENSOLA
305/0..

Fe	∞ 361	350 mm	€/u
----	-------	--------	-----



GANCHO
CROCHET
HOOK
GANCIO
*306/0..

Fe	∞ 361	200 mm	€/u
----	-------	--------	-----

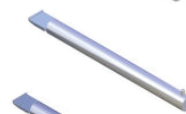

PERROQUET PLANO
PENDERIE FRONTAL
STRAIGHT ARM
APPENDERIA FRONTALE
301/0.. 250 mm
309/0.. 350 mm

Fe	∞ 361	€/u
----	-------	-----

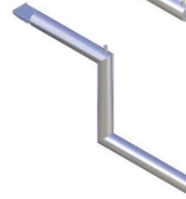

PERROQUET PLANO "S"
PENDERIE FRONTAL "S"
STRAIGHT ARM "S"
APPENDERIA FRONTALE "S"
307/0..

Fe	∞ 361	€/u
∞	361	€/u

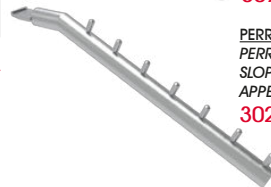

PERROQUET INCLINADO
PERROQUET INCLINÉE
SLOPING ARM
APPENDERIA INCLINADA
302/0..

Fe	∞ 361	€/u
∞	361	€/u

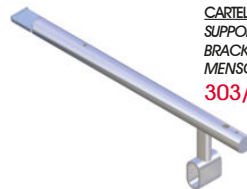

CARTELA + BARRA PENDERIE
SUPPORT + BARRE PENDERIE
BRACKET + HANGING BAR
MENSOLA + APPENDERIA
303/0..

Fe	∞ 361-4547	€/u
∞	361-4547	€/u

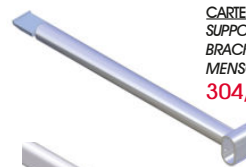

CARTELA BARRA PENDERIE
SUPPORT BARRE PENDERIE
BRACKET HANGING BAR
MENSOLA APPENDERIA
304/0..

Fe	∞ 361-4547	€/u
∞	361-4547	€/u



TUBO OVAL 36x18 mm
TUBE OVALE 36X18 mm
OVAL TUBE 36X18 mm
TUBO OVALE 36X18 mm
4547/10P

Fe	∞ 1 m	€/m
∞	36x18x1,5	€/m



TAPA FINAL CON TOPE
EMBOUT AVEC RÉTENTION
END-CAP WITH STOP
COPRITESTA + RETENZIONE
4722/0..

Zn	46x18	€/u
∞	4547 (36x18)	€/u

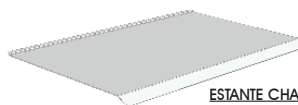

ESTANTE CHAPA
TABLETTE EN MÉTAL
METAL SHELF
RIPIANO METALLICO
*371/00M

Fe	600x380 mm	€/u
∞	361	€/u

RAL 9006
*○

LAMAS - "INVISIBLE" 403

INSTALACIÓN CON CREMALLERA

SISTEMA MACHIEMBRADO
compatibles con accesorios
estándar de "Lamas" y
especiales "Hiper"

SOCKET JOINT SYSTEM
compatible with standard accessories
"Lamas" and special accessories "Hiper"

SYSTÈME EMBOÏTEMENT
compatible avec les accessoires standard
"Lamas" et accessoires spéciaux "Hiper"

SISTEMA A INCASTRO
compatibile con accessori standard
"Lamas" e con accessori speciali "Hiper"

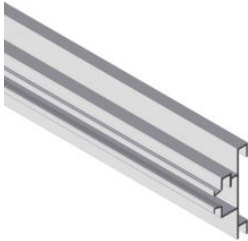

LAMA ALUMINIO CON
CREMALLERA REF. 400
MADERA: 10-16 mm
compatible con:
acc. estándar Lamas
Acc. especiales "HIPER"

PROFIL D'ALUMINIUM "LAMAS"
POUR CRÉMAILLÈRE REF 400
Bois 10-16 mm
Compatible avec:
Acc standard Lamas
Acc. spécial Hiper

ALUMINIUM PROFILE "LAMAS"
WITH RACK REF. 400
Wood 10-16 mm
Compatible with:
Acc Lamas Standard
Acc. Hiper Special

PROFILO DI ALLUMINIO "LAMAS"
CON CREMAGLIERA REF 400
Legno 10-16 mm
Compatibile con:
Acc. standard Lamas
Acc speciali Hiper
403/1..

CREMALLERA PARED
PARA PERFILES 401, 403

CRÉMAILLÈRE MUR
Avec profils 403 et 401
WALL RACK
for profiles 403 y 401
CREMAGLIERA PARETE
con profili 403 e 401
400/334

BLANCO BLANC WHITE BIANCO	NEGRO NOIR BLACK NERO	COLOR COULEUR COLOR COLORE	PL. M ALU. M ALL. NAT
OB	ON	OP	O1

Al	5 m
178x12,5	€/m

Al	3 m	∞	401-403	€/m
			ZINCADO PL. ZINK ZINK PL ZINCATO	
			34	

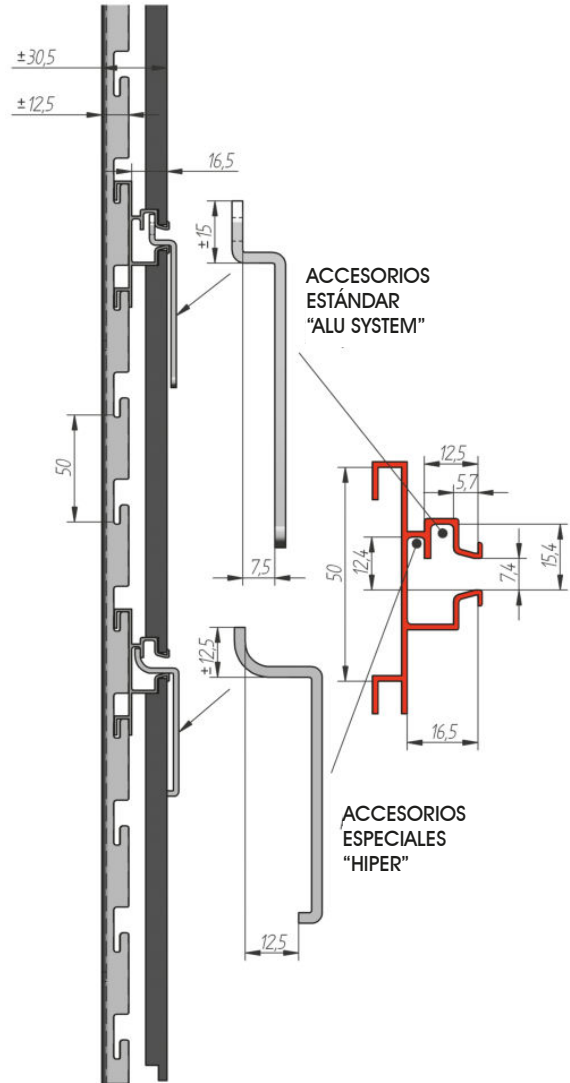
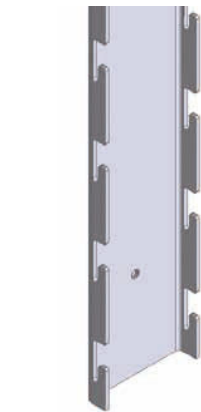

ACCESORIOS
ESTÁNDAR
"ALU SYSTEM"

ACCESORIOS
ESPECIALES
"HIPER"

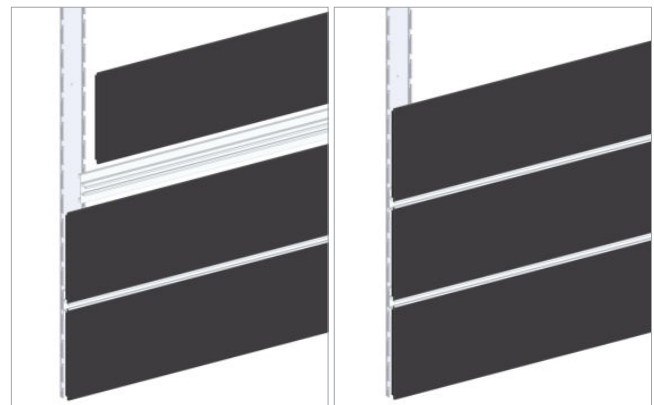
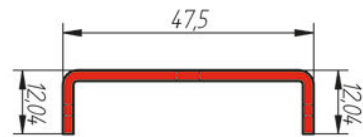

LAMAS - DM

BLANCO	NEGRO	COLOR	PL. M
BLANC	NOIR	COULEUR	ALU. M
WHITE	BLACK	COLOR	ALU. M
BIANCO	NERO	COLORE	ALL. NAT
OB	ON	OP	O1

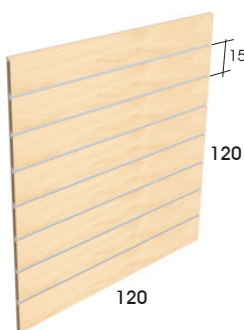

LAMA PANEL DM
regata cada 15 cm.
con perfil de aluminio "L" incluido

PANNEAU RAINURÉ MDF
Fraisé 15 cm
Profils en aluminium "L" inclus

SLATWALL PANEL MDF
Milled: 15 cm
Aluminium "L" profiles included

PANNELLO DOGATO MDF
Fresato: 15 cm
Profili "L" di alluminio inclusi

HAYA, hêtre, beech, acero
BLANCO, blanc, white, blanco

*477/12.Asta

*o *o *o

*432/12.EU

*o otros colores consultar cantidad minima 50 u.

DM	120x120
	18mm €/u

LAMA "DM" 120x120 cm

Regata cada 15 cm
con perfil de aluminio

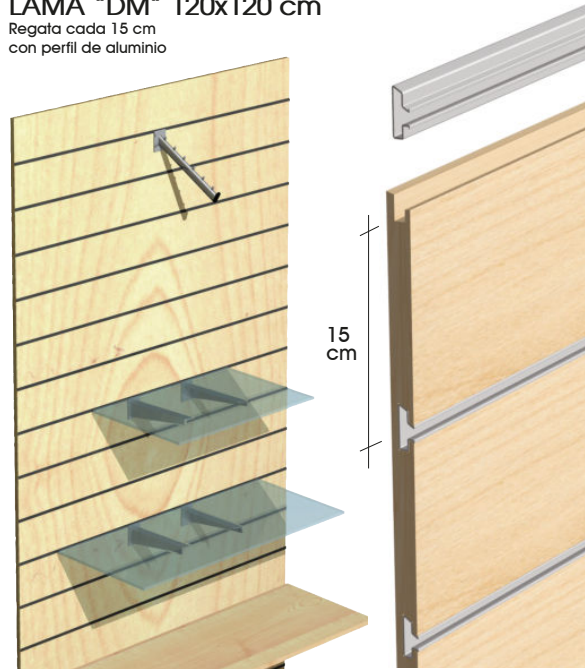

15 cm

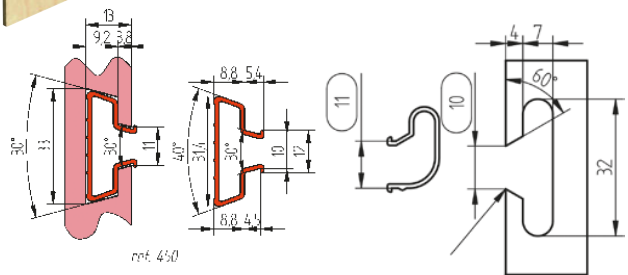

Las LAMAS tienen el terminal fresado para panelado continuo de paredes. La combinación de 2 LAMAS permite obtener una sola superficie de 2,4 x 1,2 m con 15 ranuras de aluminio, una cada 15 cm.



Fresa 450/F01

PASO 1

Fresa 450/F00

PASO 2

FRESA "T" 31 mm
FRAISE EN "T" 31 mm
"T" MILL 31 mm
FRESA A "T" 31 mm
450/F00

FRESA DIÁMETRO Ø8
FRAISE DIAMÈTRE Ø8
CUTTER DIAMETER Ø8
DIAMETRO FRESA Ø8
450/F01

Al	€/u			
		o		
Al	€/u			
		o		

SE RECOMIENDA UTILIZAR AMBAS PARA PROLONGAR EL CICLO DE VIDA DE LA FRESA

UTILIZADAS CORRECTAMENTE SU CICLO DE VIDA SE PUEDE DUPLICAR

	PERFIL DE ALUMINIO "T" PROFIL D'ALUMINIUM "T" ALUMINIUM PROFILE "T" PROFILO DI ALLUMINIO "T" 450/240 BRUTO 450/480 BRUTO	Al	4,8 m	€/u				
	PERFIL DE ALUMINIO "L" PROFIL D'ALUMINIUM "L" ALUMINIUM PROFILE "L" PROFILO DI ALLUMINIO "L" *451/120 BRUTO	Al	1,2 m	€/u				
	ÁNGULO 20x20 mm PROFIL EN "L" 20X20 PROFIL "L" SHAPE 20X20 PROFILO ANGOLARE 20X20 1651/1..	Al	5 m	€/m				
	PERFIL ESQUINERO PROFIL ANGULAIRE ANGULAR PROFIL PROFILO ANGOLARE *421/1..	Al	2,4 m	€/m				

LAMAS - ALUMINIO

BLANCO	NEGRO	COLOR	PL. M
BLANC	NOR	COULEUR	ALU. M
WHITE	BLACK	COLOR	ALU. M
BIANCO	NERO	COLORE	ALL. NAT
OB	ON	OP	O1

LAMA aluminio regata cada 75 mm

Rainure chaque 75 mm - Slot every 75 mm - Slot ogni 75 mm

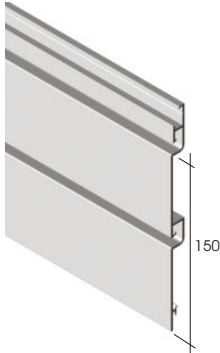

LAMA ALUMINIO "LISA"
REGATA CADA 75 mm

Al	5 m	178x12,5	€/m
----	-----	----------	-----

PROFIL LAME D'ALUMINIUM
Rainure chaque 75 mm

ALUMINIUM SLATWALL PROFILE
Slot every 75 mm

PROFILO DOGATO ALLUMINIO
Slot ogni 75 mm

427/1..

<input type="radio"/>	<input type="radio"/>	<input type="radio"/>	<input type="radio"/>
-----------------------	-----------------------	-----------------------	-----------------------

LAS LAMAS 427 Y 429 SE PUEDEN
INTERCALAR ENTRE SI

Les profils 427 et 429 peuvent être intercalés entre eux
The profiles 427 and 429 can be interspersed between them
I profili 427 e 429 possono essere intervallati tra loro

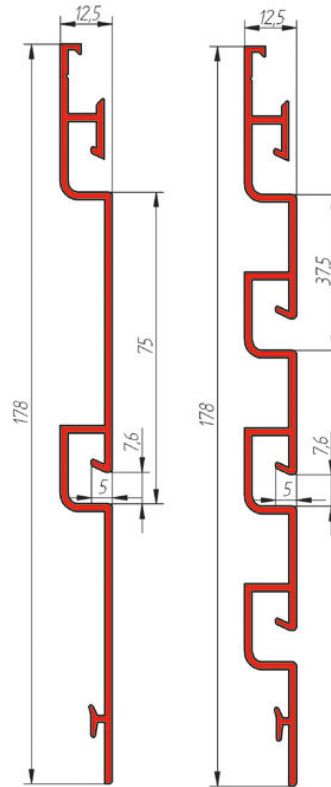

LAMA aluminio regata cada 37,5 mm

Rainure chaque 37,5 mm - Slot every 37,5 mm - Slot ogni 37,5 mm

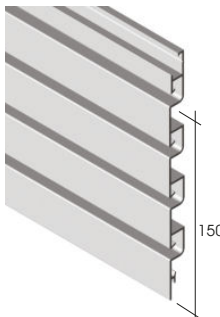

LAMA ALUMINIO,
REGATA CADA 37,5 mm

Al	5 m	178x12,5	€/m
----	-----	----------	-----

PROFIL LAME D'ALUMINIUM
Rainure chaque 37,5 mm

ALUMINIUM SLATWALL PROFILE
Slot every 37,5 mm

PROFILO DOGATO ALLUMINIO
Slot ogni 37,5 mm

429/1..

<input type="radio"/>	<input type="radio"/>	<input type="radio"/>	<input type="radio"/>
-----------------------	-----------------------	-----------------------	-----------------------

LAS LAMAS 427 Y 429 SE PUEDEN
INTERCALAR ENTRE SI

Les profils 427 et 429 peuvent être intercalés entre eux
The profiles 427 and 429 can be interspersed between them
I profili 427 e 429 possono essere intervallati tra loro

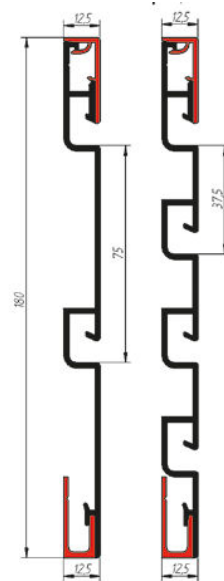

REMATES Y SOPORTES



REMATE SUPERIOR
PARA 427 Y 429

Al	5 m	30x12,5	€/m
----	-----	---------	-----

PROFIL SUPERIEUR DE FINITION

Pour 427 and 429

FINISHING UPPER PROFILE

For 427 and 429

PROFILO SUPERIORE DI FINITURA

Per 427 e 429

426/1..

<input type="radio"/>	<input type="radio"/>	<input type="radio"/>	<input type="radio"/>
-----------------------	-----------------------	-----------------------	-----------------------



PERFIL SOPORTE INFERIOR
PARA 427 Y 429

Al	5 m	28x11	€/m
----	-----	-------	-----

PROFIL INFÉRIEUR DE SUPPORT

Pour 427 and 429

LOWER SUPPORT PROFILE

For 427 and 429

PROFILO INFERIORE DI SUPPORTO

Per 427 e 429

424/1..

<input type="radio"/>	<input type="radio"/>	<input type="radio"/>	<input type="radio"/>
-----------------------	-----------------------	-----------------------	-----------------------



ÁNGULO 15x15 mm

PROFIL EN "L" 15X15

PROFIL "L" SHAPE 15X15

PROFILO ANGOLARE 15X15

1650/1..

Al	6,4 m	15x15x1,5	€/m
----	-------	-----------	-----

<input type="radio"/>	<input type="radio"/>	<input type="radio"/>	<input type="radio"/>
-----------------------	-----------------------	-----------------------	-----------------------

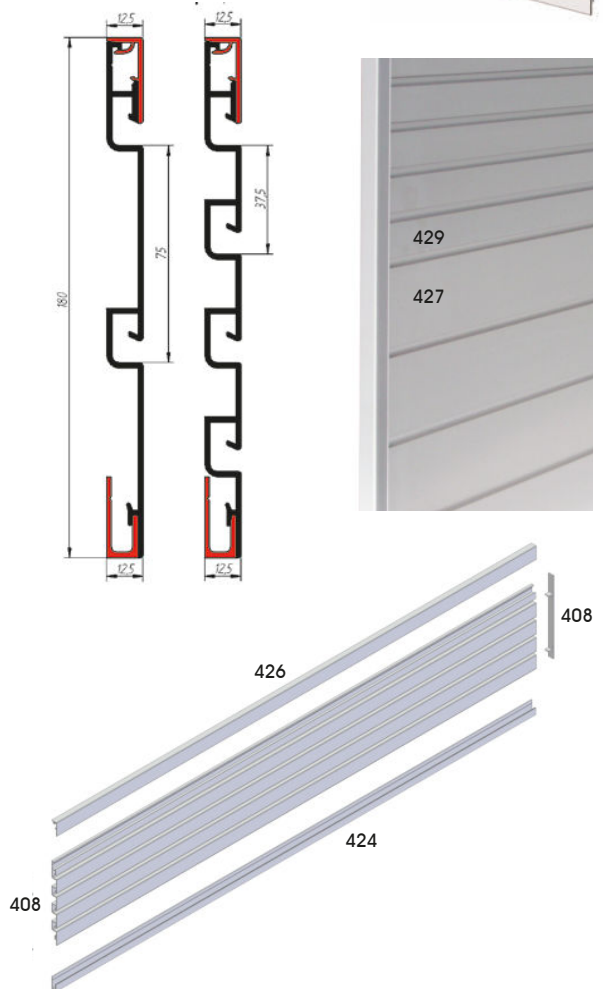

ACCESORIOS LAMAS

ACCESORIOS DE HIERRO

	CR. BRILLO CR. POLI BR. CR. CR. ILLC.	BLANCO BLANC WHITE BIANCO	NEGRO NOIR BLACK NERO	COLOR COULEUR COLOR COLORE
	32	OB	ON	OP
GANCHO CROCHET HOOK BARRETTA 418/X.. 10 cm 417/X.. 15 cm 446/X.. 20 cm 413/X.. 25 cm 414/X.. 30 cm				Fe €/u
GANCHO PORTAPRECIO CROCHET PORTAPRIX HOOK LABEL-HOLDER BARRETTA PORTAPREZZO 329/X.. 10 cm 326/X.. 15 cm 327/X.. 20 cm 328/X.. 25 cm				Fe ∞ 382 €/u
GANCHO CROCHET HOOK BARRETTA 445/X.. 20 cm				Fe €/u
GANCHO PORTAPRECIO CROCHET PORTAPRIX HOOK LABEL-HOLDER BARRETTA PORTAPREZZO 447/X.. 20 cm				Fe ∞ 382 €/u
GANCHO CROCHET HOOK BARRETTA *448/X.. 20 cm				Fe €/u
GANCHO CROCHET HOOK BARRETTA 441/X.. 20 cm 442/X.. 15 cm				Fe €/u
GANCHO PORTAPRECIO CROCHET PORTAPRIX HOOK LABEL-HOLDER BARRETTA PORTAPREZZO 381/X.. 15 cm 380/X.. 25 cm				Fe ∞ 382 €/u
PORTAPRECIO PORTAPRIX LABELHOLDER PORTAPREZZO 382/009	plas	40x50 mm		€/u
BLOQUEO GANCHO BLOCAGE BROCHE HOOK SECURITY LOCK BLOCCO SICUREZZA GANCIO 373/00N	plas	∅6 mm		€/u
BLOQUEO GANCHO DOBLE BLOCAGE BROCHE DOUBLE DOUBLE HOOK SECURITY LOCK BLOCCO GANCIO DOPPIO 383/00N	plas	∅6 mm		€/u
IMÁN ESPECIAL DESBLOQUEO UNLOCK MAGNET UNLOCK MAGNET MAGNETE DI SBLOCCO 384/000	plas	373-383/00N		€/u
CARTELA ESTANTE VIDRO SUPPORT TABLETTES VERRE GLASS SHELF BRACKET MENSOLA RIPIANO VETRO 488/X.. derecha droite/right/destra 487/X.. izquierda gauche/left/sinistra				Fe 8-10 mm €/u
CARTELA ESTANTE VIDRO SUPPORT TABLETTES VERRE GLASS SHELF BRACKET MENSOLA RIPIANO VETRO 482/X.. derecha droite/right/destra 483/X.. izquierda gauche/left/sinistra				Fe 8-10 mm €/u

	CR. BRILLO CR. POLI BR. CR. CR. ILLC.	BLANCO BLANC WHITE BIANCO	NEGRO NOIR BLACK NERO	COLOR COULEUR COLOR COLORE
	32	OB	ON	OP
CARTELA ESTANTE MADERA SUPPORT TABLETTES BOIS WOOD SHELF BRACKET MENSOLA RIPIANO LEGNO 489/X.. derecha droite/right/destra 490/X.. izquierda gauche/left/sinistra				Fe 19 mm €/u
CARTELA ESTANTE MADERA SUPPORT TABLETTES BOIS WOOD SHELF BRACKET MENSOLA RIPIANO LEGNO 480/X.. derecha droite/right/destra 484/X.. izquierda gauche/left/sinistra				Fe 250 mm €/u
PERROQUET INCLINADO PERROQUET INCLINÉE SLOPING ARM APPENDERIA INCLINADA 465/X..				Fe 300 mm €/u
PERROQUET PLANO PENDERIE FRONTAL STRAIGHT ARM APPENDERIA FRONTALE 472/X..				Fe 300 mm €/u
PERROQUET PLANO "Z" PENDERIE FRONTAL "Z" STRAIGHT ARM "Z" APPENDERIA FRONTALE "Z" 469/X..				Fe 350 mm €/u
BARRA PENDERIE BARRE PENDERIE HANGING BAR BARRA APPENDERIA 459/X..				Fe 90x30 cm 12 kg/u €/u
SOPORTE CORBATERO SUPPORT TIE RACK SUPPORT PORTE-CRAVATES SUPPORTO PORTACRAVATTE *473/X..				Fe ∅ 342 mm €/u
SOPORTE CASCO HELMET SUPPORT SUPPORT CASQUE MOTO SUPPORTO CASCO 462/X..				Fe ∅ 116 mm €/u
SOPORTE PELOTA BALL SUPPORT SUPPORT DE BALLON SUPPORTO PALLA 461/X..				Fe ∅ 130 mm €/u
ESTANTE REJILLA FLAT GRID SHELF ÉTAGÈRE PLAN DE GRILLE RIPIANO GRIGLIA *464/X..				Fe 600x310 mm €/u
CESTA REJILLA GRID BASKET PANIER DE GRILLE CESTINO GRIGLIA *463/X..				Fe 600x310 mm €/u
SOPORTE CALZADO SOUTIEN CHAUSSANT FOOTWEAR SUPPORT SUPPORTO CALZATURE 491/X..				Fe 250x100 mm €/u



BLANCO BLANC WHITE BIANCO	NEGRO NOR BLACK NERO	COLOR COULEUR COLOR COLORE	PL. M ALU. M ALU. M ALL. NAT
OB	ON	OP	O1

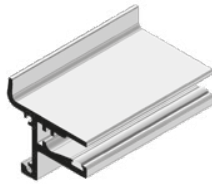

LAMA ALUMINIO
PROFIL LAME D'ALUMINIUM
ALUMINIUM SLATWALL PROFILE
PROFILO DOGATO ALLUMINIO

*362/1.. *o *o *o *o

Junta goma incluida
Joint en caoutchouc inclus
Rubber gasket included
Giunta di gomma inclusa

Al	6-8 mm	€/m
∞ 361/1...	5 m	

Perfil aluminio 362

- Admite estante de vidrio de 6 y 8 mm.
(SE RECOMIENDA VIDRIO DE SEGURIDAD).
- Admite iluminación LED en el canal del perfil.

Aluminum profile, 362
- Allows glass shelf 6 and 8 mm thickness.
(SAFETY GLASS IS RECOMMENDED)
- Allows LED lighting.

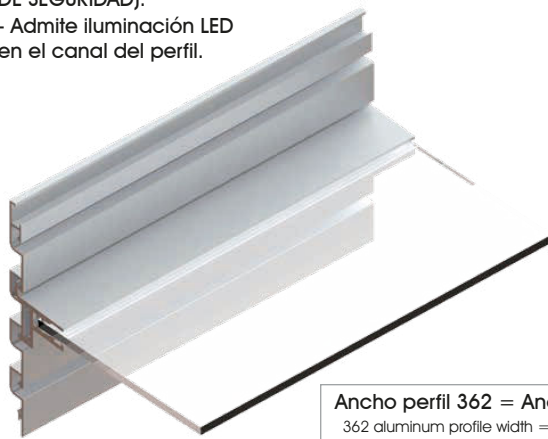

Ancho perfil 362 = Ancho vidrio
362 aluminum profile width = Glass width
Largeur du profil 362 = Largeur de verre
Larghezza profilo 362 = Larghezza di vetro

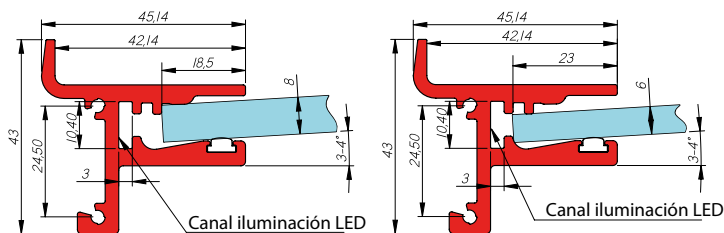

ACCESORIOS DE ALUMINIO



PERROQUET PLANO
PENDERIE FRONTAL
STRAIGHT ARM
APPENDERIA FRONTALE
*394/001

Al	325 mm	€/u
----	--------	-----

O1

PERROQUET INCLINADO
PERROQUET INCLINÉE
SLOPING ARM
APPENDERIA INCLINADA
*395/001

Al	315 mm	€/u
----	--------	-----

*o

ACCESORIOS DE PLÁSTICO

PLÁSTICO PLASTIQUE PLASTIC PLASTICA
O9



ESTANTE INCLINADO 25°
TABLETTE INCLINÉ
SHELF INCLINED 25°
RIPIANO INCLINATO 25°
*435/009

plas	200x100
------	---------

transp.	€/u
---------	-----

*o

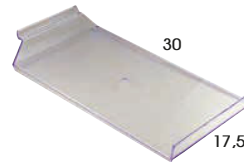

SOPORTE GORRA
TABLETTE CHAPEAU
HAT SHELF
MENSOLA CAPPELLO
*452/009

plas	175x300
------	---------

transp.	€/u
---------	-----

*o



PERROQUET PARA BOLSOS
PERROQUET POUR SACS
ARM FOR HANGING BAGS
APPENDERIA PER BORSE
*443/009

plas	370 mm
------	--------

transp.	€/u
---------	-----

*o



SOPORTE LIBROS, ETC.
SUPPORT LIVRE DROITE
BOOK HOLDER RIGHT
SUPPORTO LIBRO DESTRA
*439/009 derecha

plas	
------	--

transp.	€/u
---------	-----

*o



SOPORTE LIBROS, ETC.
SUPPORT LIVRE GAUCHE
BOOK HOLDER LEFT
SUPPORTO LIBRO SINISTRA
*440/009 izquierda

plas	
------	--

transp.	€/u
---------	-----

*o

PARALELO 384

Empotrable, fijación a panel para estantes de 5, 6 mm ó 8 mm
Peso max. recomendado: 20 kg/ml (ver instrucciones)

ENCASTRÉ, MONTAGE SUR PANNEAU
TABLETTE 5, 6 ou 8 mm
POIDS MAX. RECOMMANDÉE: 20 kg / ml
(VOIR LES INSTRUCTIONS)

EMBEDDED, PANEL MOUNTING
SHELF 5, 6 mm or 8 mm
MAX. RECOMMENDED: 20 kg / ml
(SEE INSTRUCTIONS)

A INCASSO, MONTAGGIO A PANNELLO
SHELF 5, 6 O 8 mm
PESO MASS. CONSIGLIATO:
20 kg / ml (VEDI ISTRUZIONI)

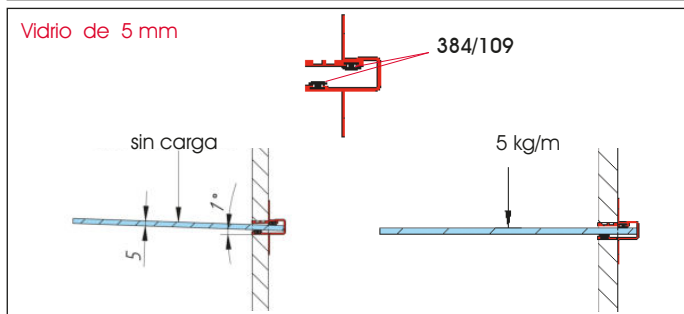
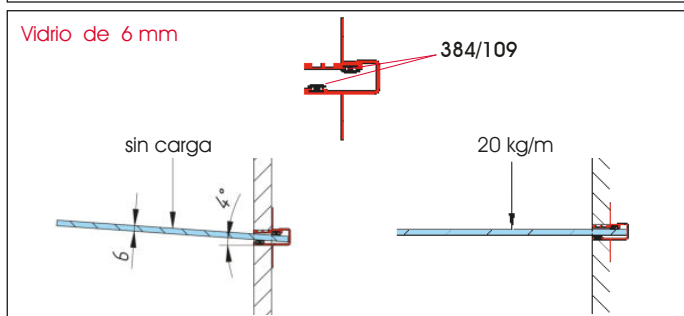
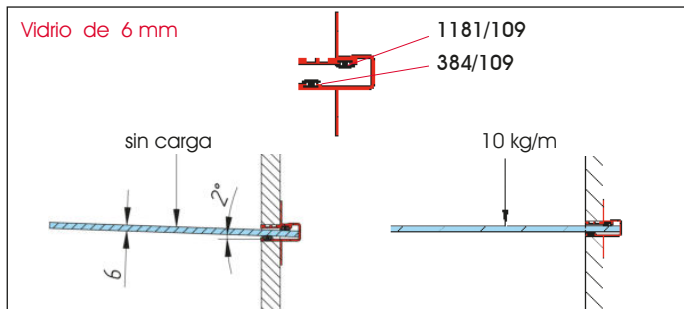
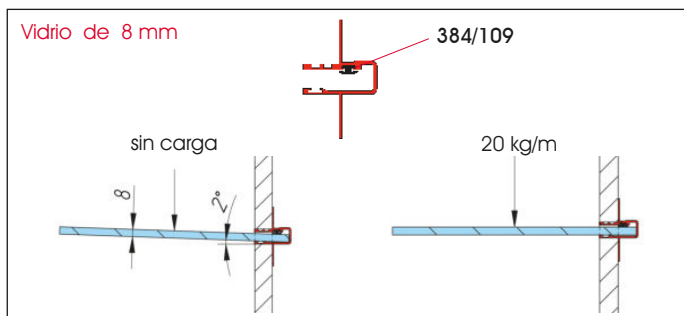

MONTAJE

MONTAGE, MOUNTING, MONTAGGIO

Debido a la deformación de las gomas por acción del peso soportado por el estante, se recomienda combinar distintos espesores de vidrio+gomas en relación al peso previsto.
NOTA: Se recomienda utilizar estantes de vidrio de seguridad (según la normativa en espacios públicos y para una mayor resistencia).

En raison de la déformation du caoutchouc par l'action du poids supporté par le tablette, il est recommandé de combiner différentes épaisseurs de verre + caoutchouc en rapport de poids attendus.
NOTE: Nous vous recommandons d'utiliser tablettes en verre de sécurité (en vertu des règles dans les espaces publics et pour plus de solidité).

Due to deformation of the rubbers by the action of weight supported by the shelf, it is recommended to combine various glass thicknesses + rubbers depending on the weight expected.
NOTE: We recommend using safety glass shelves (under the rules in public spaces and for greater resistance).

A causa della deformazione delle gomme per l'azione del peso sostenuto dal ripiano, si consiglia di combinare vari spessori vetro + gomme in relazione al peso previsto.
NOTA: Si consiglia utilizzare ripiani di vetro di sicurezza (nel rispetto delle norme in spazi pubblici e per una maggior resistenza).

Para un estante de 80 cm (max. recomendado):
Pour une étagère de 80 cm (max. recommandé): 80 cm
For a shelf 80 cm long (max. recommended): 80cm
Per un ripiano di 80 cm di lunghezza (massimo raccomandato): 80 cm

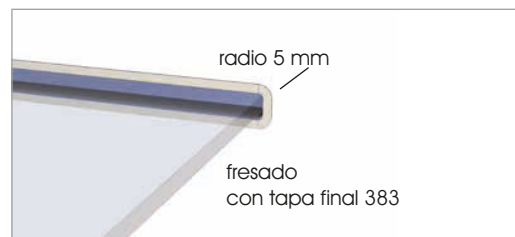
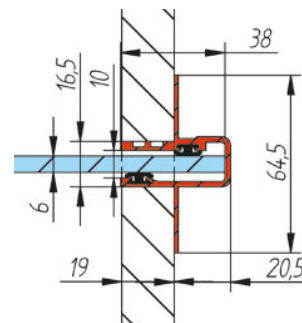

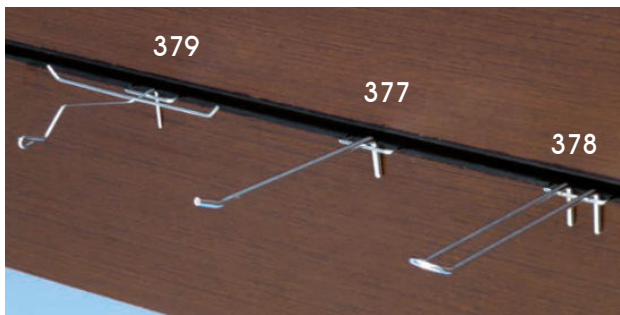
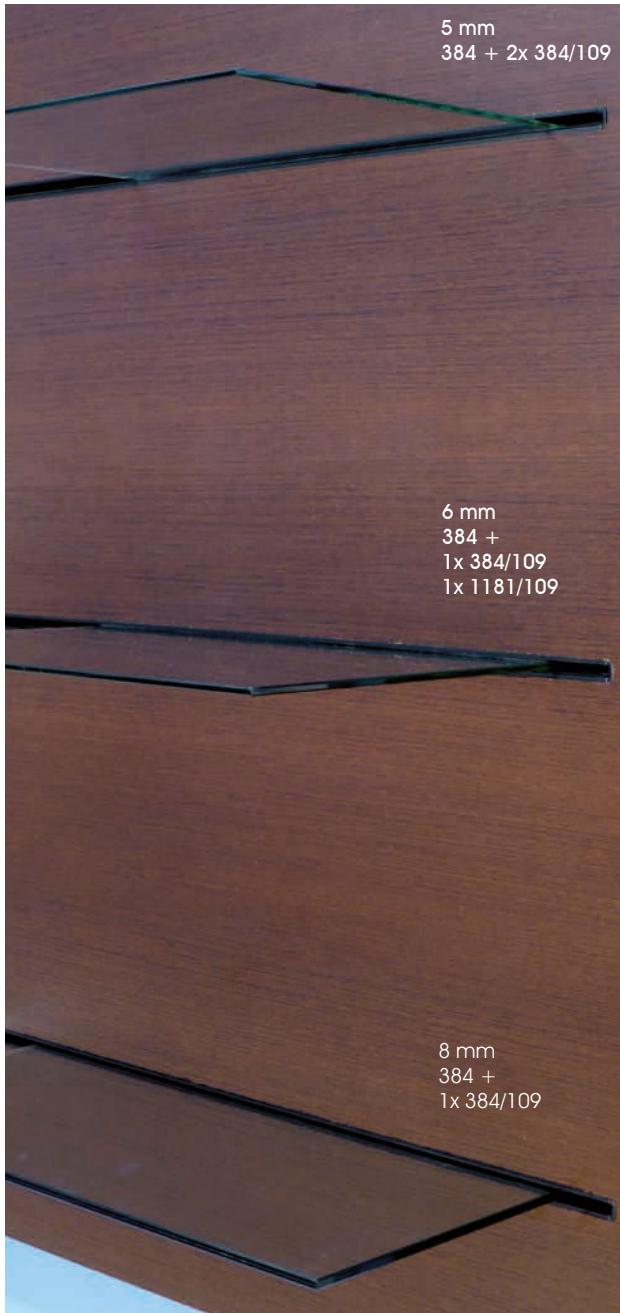

ACCESORIOS

PL. M	COLOR	BLANCO	NEGRO	OR. BRILLO
ALU. M	COULEUR	BLANC	NOIR	OR. POLI
ALL. M	COLOR	WHITE	BLACK	BR. CHR
ALL. NAT	COLORE	BIANCO	NERO	OR. LUC.
01	0P	0B	0N	32

	PERFIL INVISIBLE PROFIL D'ALUMINIUM ALUMINIUM PROFILE PROFILO DI ALLUMINIO 384/1..	Al	5 m	5/6/8 mm	∞ 384/1181
	GOMA DURA CAOUTCHOUC DUR HARD RUBBER GOMMA DURA 384/109				plas ∞ 384 €/m
	GOMA BLANDA CAOUTCHOUC SOUPLE SOFT RUBBER GOMMA MORBIDA 1181/109				plas ∞ 384 €/m
	TAPA FINAL CABOCHON profil 384 END-CAP 384 profile COPRITESTA profilo 384 383/OOP GRIS 383/TON NEGRO				plas ∞ 384 €/u
	GANCHO BROCHE HOOK BARRETTA *377/032 20 cm				Fe €/u
	GANCHO SEGURIDAD DOUBLE BROCHE DOUBLE HOOK BARRETTA DOPPIA *378/032 20 cm				Fe €/u
	GANCHO GAFAS SUPPORT FOR GLASSES SUPPORT POUR LUNETTES BARRETTA PER OCCHIALI *379/032				Fe €/u

PERFIL PARALELO MAXI 389

- Admite estante de vidrio de 8 mm **SE RECOMIENDA VIDRIO DE SEGURIDAD**

- Sistema machihembrado
- Peso max. admitido: 30 kg/ml
- Admite iluminación LED

LAMA aluminium INVISIBLE 389
- Permet étagère en verre 8 mm d'épaisseur
Verre de sécurité est recommandé
- montage panneau à emboîtement
- Max. poids admis: 25 kg / ml
- Permet l'éclairage LED

LAMA aluminium INVISIBLE 389
- Allows glass shelf 8 mm thick
Safety glass is recommended
- Socket joint
- Max. admitted weight 30 kg / ml
- Allows LED lighting

LAMA alluminio INVISIBLE 389
- ammette ripiani in vetro 8 mm
Si raccomanda l'uso di vetro sicurizzato
- Sistema incastro
- Peso massimo ammesso: 30 kg/ml
- Ammette LEDs

	PERFIL INVISIBLE PARED "MAXI"	BRUTO BRUT GREZZO 00
	LAMA ALUMINIO PROFIL D'ALUMINIUM ALUMINIUM PROFILE PROFILO DI ALLUMINIO NO COMPATIBLE con acc. 385, 386, 387, 388. *389/100	Al
		8 mm
		30kg/m
		€/m
		*o

OPTI 3

PERFIL INVISIBLE PARA ESTANTES Y ACCESORIOS DE 3MM DE ESPESOR

SISTEMA MACHIHEMBRADO
SYSTÈME EMBOÎTEMENT
SOCKET JOINT SYSTEM
SISTEMA A INCASTRO

BLANCO	NEGRO	COLOR	PL. M
BLANC	NOIR	COULEUR	ALU. M
WHITE	BLACK	COLOR	ALU. M
BIANCO	NERO	COLORE	ALL. NAT

OB	ON	OP	O1
----	----	----	----



PERFIL INVISIBLE PARA ESTANTES DE 3 MM DE ESPESOR
PROFIL INVISIBLE POUR ÉTAGÈRES 3 MM D'ÉPAISSEUR
INVISIBLE PROFILE FOR SHELVES 3 MM THICK
PROFILO INVISIBLE PER RIPIANI DI 3 MM DI SPESSORE

Al	5 m	€/m
6/8 mm		

360/1..

<input type="radio"/>	<input type="radio"/>	<input type="radio"/>	<input type="radio"/>
-----------------------	-----------------------	-----------------------	-----------------------

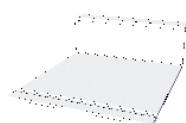

ESTANTE EXTRUSIONADO 3 MM
SUPPORT-TABLETTE 3MM
FOLDED BRACKET-SHELF 3 MM
MENSOLA-RIPIANO PIEDATA 3 MM
387/0.. 190MM
(POSIBILIDAD DE CORTE A MEDIDA BAJO PEDIDO)

Al	190x190x50 mm	€/u
----	---------------	-----

387/0..

<input type="radio"/>	<input type="radio"/>	<input type="radio"/>
-----------------------	-----------------------	-----------------------

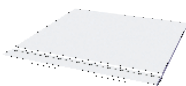

BANDEJA SIMPLE 3 MM
SUPPORT-TABLETTE 3MM
BRACKET-SHELF 3 MM
MENSOLA-RIPIANO 3 MM
388/0..

Fe	190x210 mm	€/u
----	------------	-----

388/0..

<input type="radio"/>	<input type="radio"/>	<input type="radio"/>
-----------------------	-----------------------	-----------------------

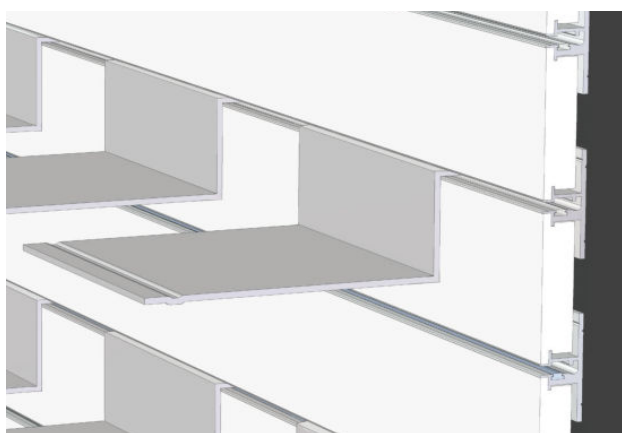
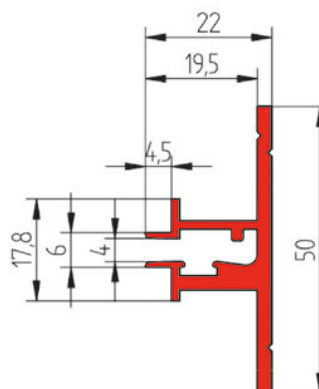

INFORMACIÓN TÉCNICA OPTI-3

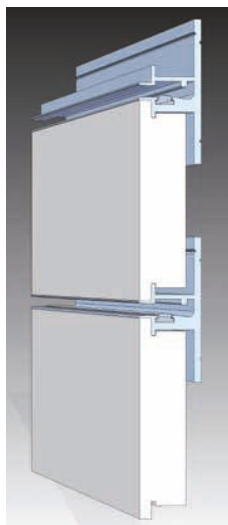

Madera 16 mm



Madera 19 mm

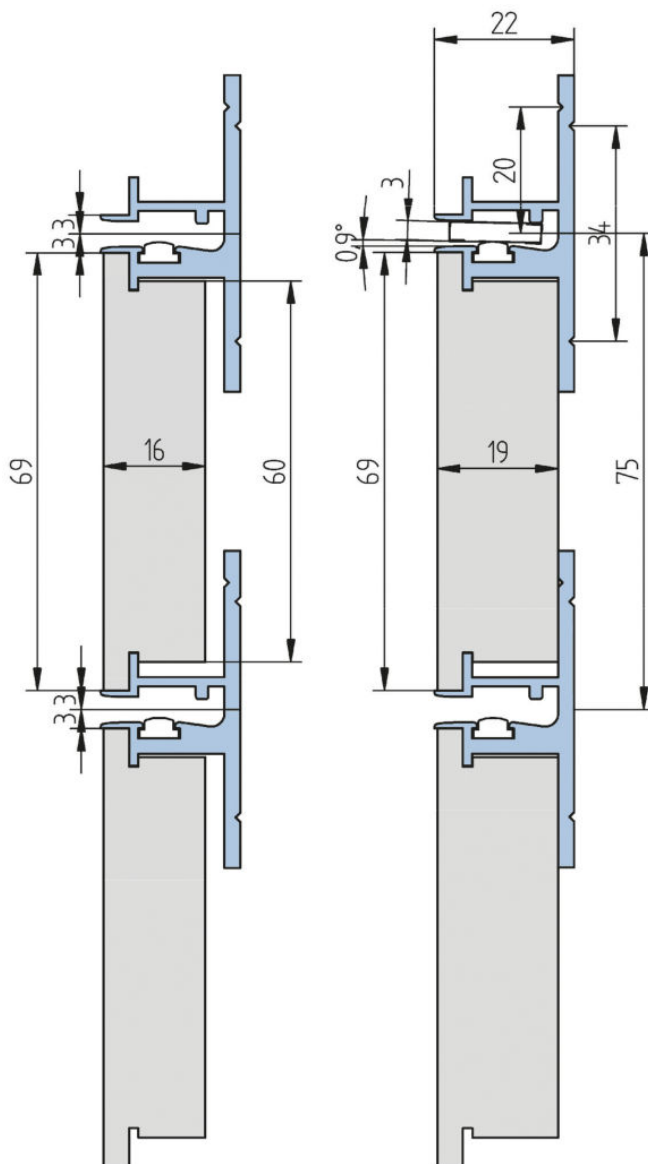
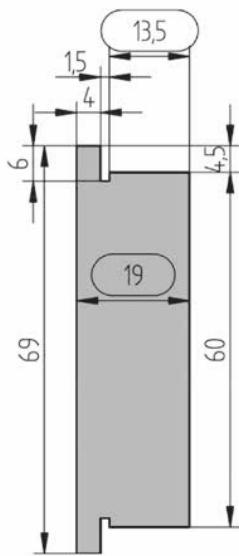
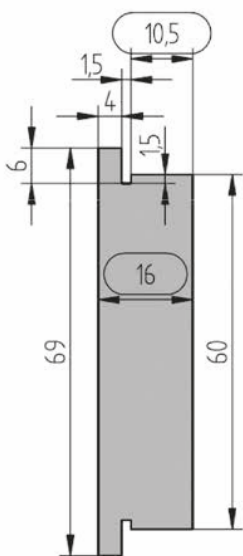

Madera 19 mm

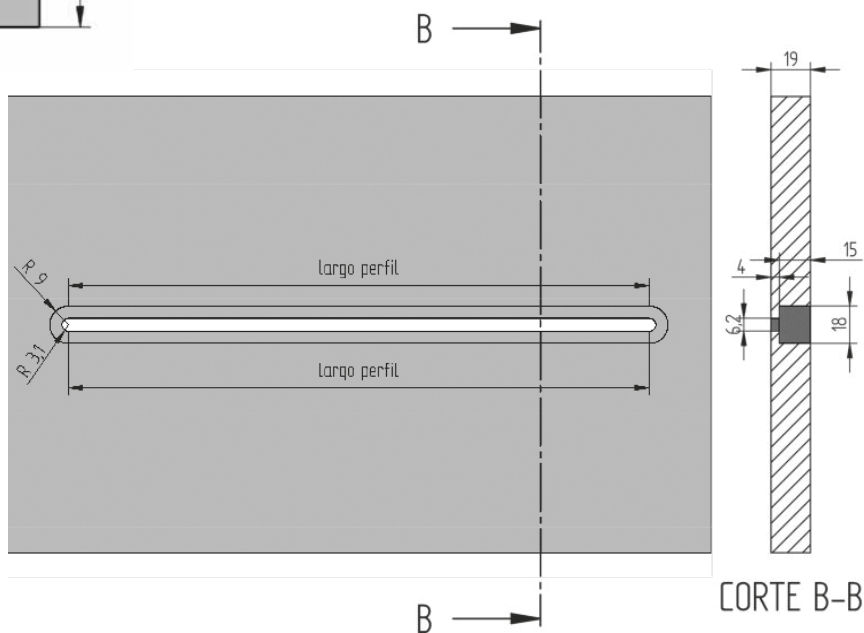





instal.

MULTILAMAS Y VERTICAL

SISTEMAS DE ACCESORIOS COMPATIBLES

MULTILAMA

MONTAJE
INFORMACIÓN TÉCNICA
COMPONENTES
REMATE LATERAL
COMPONENTES
ACCESORIOS SOLO PARA

MULTILAMA
ANGULOS Y "US"

VERTICAL

INFORMACIÓN TÉCNICA
MONTAJE
COMPONENTES
GÓNDOLAS
ACCESORIOS GÓNDOLAS
ACCESORIOS COMUNES

MULTILAMA



MONTAJE

1. Colocar las cremalleras 400 a una distancia de 30-40 cm entre ellas, dependiendo de la carga a soportar. Con paredes de Pladur se recomienda fijar las cremalleras a los montantes estructurales de la misma.
2. Se recomienda evitar colocar los accesorios con peso en la ranura de unión entre una lama y la otra.

1. Placing the racks 400 at a distance of 30-40 cm between them, depending on the load to be supported. With plasterboard walls is recommended to set the racks to the same structural uprights.

2. It is recommended to avoid placing accessories in the slot between 2 profiles.

1. Placer les crémaillères 400 à une distance de 30 à 40 cm entre eux, en fonction de la charge à supporter. Avec des murs en plaques de plâtre est recommandé de fixer les crémaillères pour les mêmes montants de structure.

2. Il est recommandé d'éviter de placer le poids de les accessoires en la joint de deux profils.

1. Montare i profili cremagliera a una distanza di 30-40 cm fra loro, in funzione del peso che deve sopportare. Con pareti di cartongesso, si raccomanda fissare i montanti direttamente alla struttura della stessa parete.

2. Si raccomanda evitare la collocazione degli accessori nella ranura corrispondente all'unione di 2 profili.

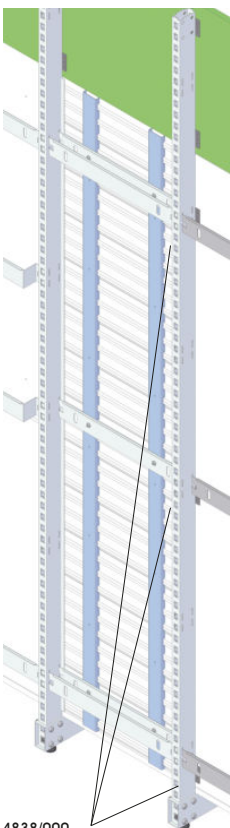

Solución con MULTILAMA

Solution avec MULTILAMA
Solution with MULTILAMA
Soluzione con MULTILAMA



MONTAJE FRONTAL
montage frontal
front mounting
montaggio frontale

1650/1..
REMATE ÁNGULO 15X15
profil lateral de finition
lateral finishing profile
profilo laterale di finitura

1651/1..
REMATE ÁNGULO 20X20
profil lateral de finition
lateral finishing profile
profilo laterale di finitura



ESCONDIDO
caché
hidden
nascosto

4838/000
ANCLAJE MULTILAMA
Support Multilama
Support Multilama
Supporto Multilama

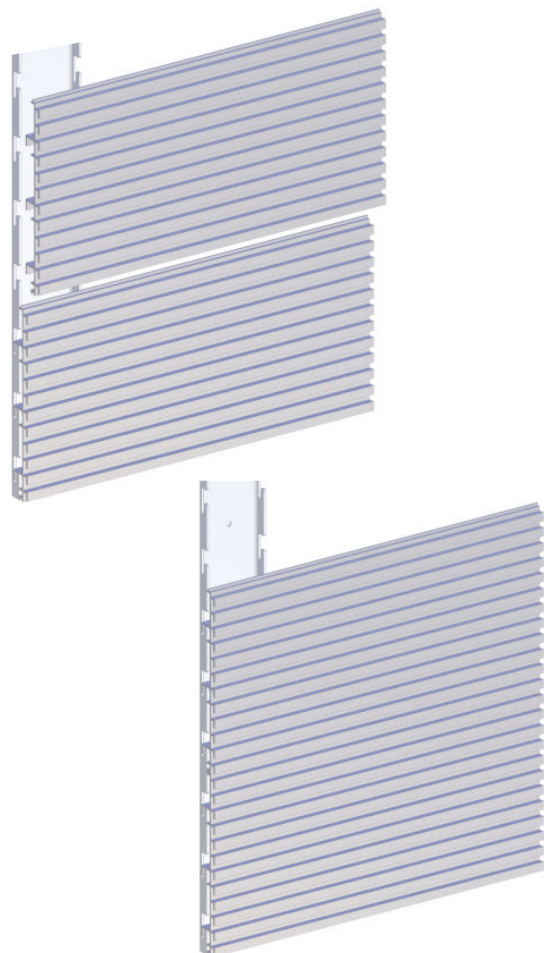

INFORMACIÓN TÉCNICA MULTILAMA

MULTILAMA aluminio regata cada 12,5 mm
 Rainure chaque 12,5 mm - Slot every
 12,5 mm - Slot ogni 12,5 mm

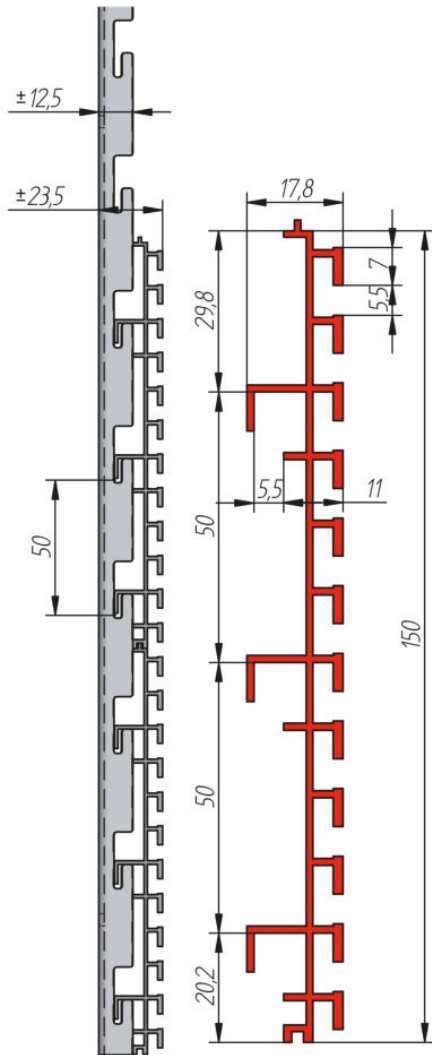

REMATE LATERAL

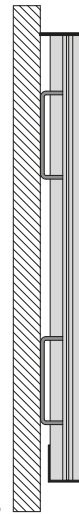
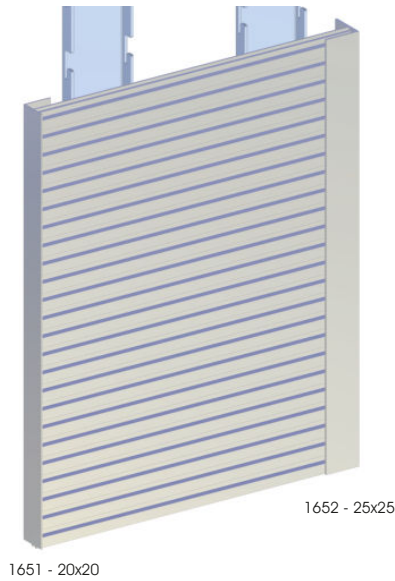

MONTAJE FRONTAL
 montage frontal
 front mounting
 montaggio frontale
 1652 - 25x25
 pegada por delante

ESCONDIDO
 caché
 hidden
 nascosto
 1651 - 20x20
 pegada por atrás

GUÍA 400



COMPONENTES

MULTILAMA aluminio regata cada 12,5 mm
Rainure chaque 12,5 mm - Slot every 12,5 mm - Slot ogni 12,5 mm

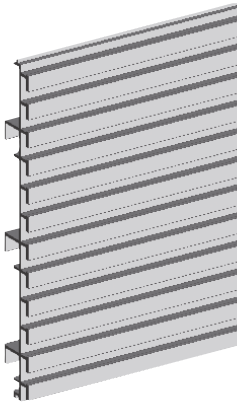

Guía pared
MULTILAMA

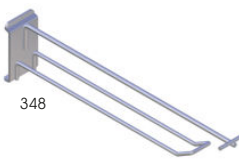
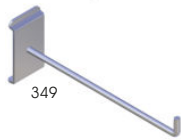
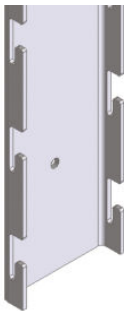

MULTILAMA ALUMINIO
12 CANALES (12,5 MM)
PROFIL LAME D'ALUMINIUM
12 rainures chaque 12,5 mm
ALUMINIUM SLOT/WALL PROFILE
12 Slots every 12,5 mm
PROFLO DOGATO ALLUMINIO
12 ranure ogni 12,5 mm
401/1..

CREMALLERA PARED
PARA PERFILES 401...403
CRÉMAILLÈRE MUR
Avec profils 403 et 401
WALL RACK
for profiles 403 y 401
CREMAGLIERA PARETE
con profili 403 e 401
400/334

GANCHO
CROCHET
HOOK
GANCIO
332/0.. 10 cm
352/0.. 15 cm
349/0.. 20 cm
353/0.. 25 cm
350/0.. 30 cm

GANCHO PORTAPRECIO
CROCHET PORTAPRIX
HOOK LABEL-HOLDER
GANCIO PORTAPREZZO
334/0.. 15 cm
338/0.. 20 cm
348/0.. 25 cm

PORTAPRECIO
PORTAPRIX
LABELHOLDER
PORTAPREZZO
382/009

BLOQUEO GANCHO
BLOCCAGE BROCHE
HOOK SECURITY LOCK
BLOCCO SICUREZZA GANCIO
373/00N

BLOQUEO GANCHO DOBLE
BLOCCAGE BROCHE DOUBLE
DOUBLE HOOK SECURITY LOCK
BLOCCO GANCIO DOPPIO
383/00N

IMÁN ESPECIAL DESBLOQUEO
UNLOCK MAGNET
UNLOCK MAGNET
MAGNETE DI SBLOCCO
384/000

BLANCO BLANC WHITE BIANCO	NEGRO NOIR BLACK NERO	COLOR COULEUR COLOR COLORE	PL.M ALU.M ALL.NAT
OB	ON	OP	01

Al	5 m	∞	400	€/m
----	-----	---	-----	-----

ZINCADO PL. ZNK ZINK PL. ZINCATO
34

Al	3 m	∞	401-403	€/m
----	-----	---	---------	-----

CR. BRILLO CHR. POLI BR. CHR. CR. ILLC.
32

Fe	∞	401	€/u
----	---	-----	-----

Fe	∞	401-382	€/u
----	---	---------	-----

plas	40x50 mm	€/u
------	----------	-----

plas	∅6 mm	€/u
------	-------	-----

plas	∅6 mm	€/u
------	-------	-----

plas	373-383/00N	€/u
------	-------------	-----

plas	373-383/00N	€/u
------	-------------	-----

ACCESORIOS SOLO
PARA MULTILAMA

ACCESSOIRES SEULEMENT POUR MULTILAMA
ACCESSORIES ONLY FOR MULTILAMA
ACCESSORI SOLO PER MULTILAMA

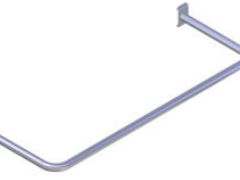
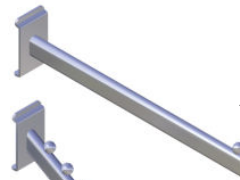
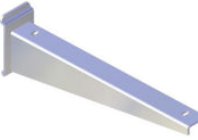
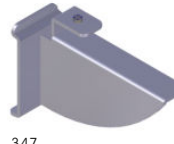
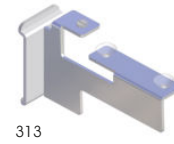
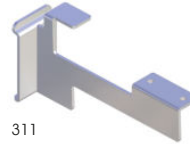

CARTELA ESTANTE MADERA
SUPPORT TABLETTE BOIS
WOOD SHELF BRACKET
MENSOLA RIPIANO LEGNO
310/0.. derecha
droite/right/destra
311/0.. izquierda
gauche/left/sinistra

CARTELA ESTANTE VIDRO
SUPPORT TABLETTE VERRRE
GLASS SHELF BRACKET
MENSOLA RIPIANO VETRO
312/0.. derecha
droite/right/destra
313/0.. izquierda
gauche/left/sinistra

CARTELA ESTANTE VIDRO
SUPPORT TABLETTE VERRRE
GLASS SHELF BRACKET
MENSOLA RIPIANO VETRO
346/0.. derecha
droite/right/destra
347/0.. izquierda
gauche/left/sinistra

CARTELA ESTANTE MADERA
SUPPORT TABLETTE BOIS
WOOD SHELF BRACKET
MENSOLA RIPIANO LEGNO
344/0.. derecha
droite/right/destra
340/0.. izquierda
gauche/left/sinistra

PERROQUET PLANO
PENDERIE FRONTAL
STRAIGHT ARM
APPENDERIA FRONTALE
343/0..

PERROQUET INCLINADO
PENDERIE INCLINÉE
SLOPING ARM
APPENDERIA INCLINADA
342/0..

BARRA PENDERIE
BARRE PENDERIE
HANGING BAR
BARRA APPENDERIA
351/0..

BLANCO BLANC WHITE BIANCO	NEGRO NOIR BLACK NERO	COLOR COULEUR COLOR COLORE	CR. BRILLO CHR. POLI BR. CHR. CR. ILLC.
OB	ON	OP	32

Fe	19 mm	∞	401	€/u
----	-------	---	-----	-----

Fe	8-10 mm	∞	401	€/u
----	---------	---	-----	-----

Fe	8-10 mm	∞	401	€/u
----	---------	---	-----	-----

Fe	250 mm	∞	401	€/u
----	--------	---	-----	-----

Fe	300 mm	∞	401	€/u
----	--------	---	-----	-----

Fe	300 mm	∞	401	€/u
----	--------	---	-----	-----

Fe	90x30 cm	∞	401	€/u
12 kg/u				

ÁNGULOS Y "US"

PROFILES "L" ET "U" / "L" AND "U" PROFILES /
PROFILI "L" E "U"



ÁNGULO 20x20 mm
PROFIL EN "L" 20X20
PROFIL "L" SHAPE 20X20
PROFILO ANGOLARE 20X20
1651/1..

ÁNGULO 25x25 mm
PROFIL EN "L" 25X25
PROFIL "L" SHAPE 25X25
PROFILO ANGOLARE 25X25
1652/1..

PL. M ALU. M ALL. NAT	ORO DORÉ GOLD DOR. OP	M BLANC M WHITE M BIANCO	NEGRO NOIR BLACK NERO	COLOR COULEUR COLOR COLORE
01	03	OB	ON	OP

Al	5 m	20x20x1 mm	€/m
----	-----	------------	-----

Al	5 m	25x25x1,5 mm	€/m
----	-----	--------------	-----

VERTICAL

CARACTERÍSTICAS

- Sistema modular que se adapta a cualquier medida entre montantes
- permite montantes individuales
- Estantes de madera y vidrio de 20 a 35 cm de fondo
- Se puede pintar en cualquier color

CARACTÉRISTIQUES - FEATURS - CARATTERISTICHE

- Système modulaire réglable pour chaque distance entre montants
- Modular system adjustable for each distance between uprights
- Sistema modulare regolabile per ogni distanza fra piantane

- Permet tube-crémallères individuels
- allows individual uprights
- permette piantane individuali

- Tablettes en bois et verre de 20 à 35 cm de profondeur
- Wooden and glass shelves of 20-35 cm deep
- Ripiani di legno e vetro da 20 a 35 cm di fondo

- Il peut être peint dans toutes les couleurs
- It can be painted in any color
- si può verniciare in qualsiasi colore





2638



2630



2634



2636



2632



2634

INFORMACIÓN TÉCNICA VERTICAL

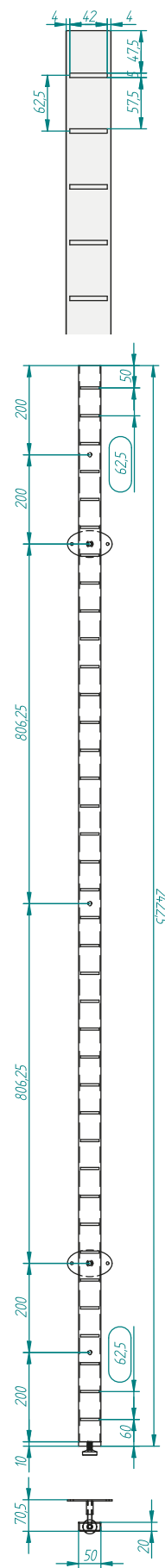

MONTAJE VERTICAL

1. Montaje a pared

Sistema modular que se adapta a cualquier medida de eje entre montantes.

MONTAGE MURAL Système modulaire réglable

pour chaque distance entre montants

WALL MOUNTING Modular system adjustable for

each distance between uprights

MONTAGGIO A PARETE Sistema modulare

regolabile per ogni distanza fra piantane

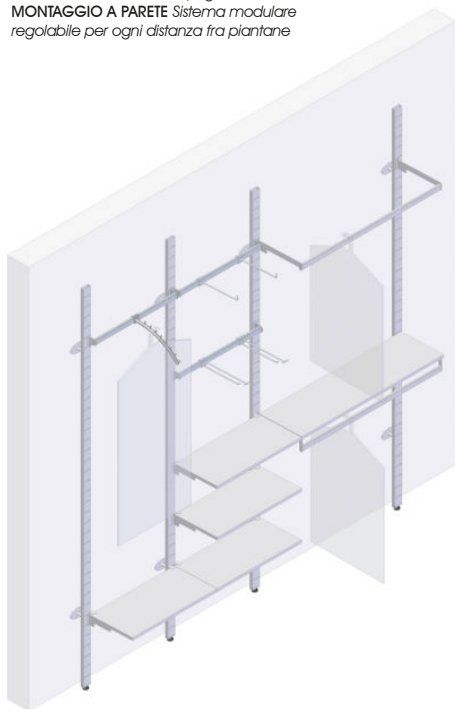

2. Montaje a pared

Total libertad de combinación compoitiva con estantes repartidos entre montantes o estantes individuales

MONTAGE MURAL tablettes divisées entre les

poteaux ou étagères individuelles

WALL MOUNTING shelves divided between

uprights or individual shelves

MONTAGGIO A PARETE ripiani condivisi fra

piantane o scaffalature individuali



3. Montaje a pared

Posibilidad de usar montantes individuales

con accesorios del sistema Multilamas.

MONTAGE MURAL Permet tube-crémaillères

individuels avec accessoires MULTILAMA

WALL MOUNTING allows individual uprights with

MULTILAMA fittings

MONTAGGIO A PARETE permette piantane

individuali con accessori MULTILAMA



4. Display autoportante

Múltiplas combinaciones para hacer góndolas

Multiple combinations pour displays autoportantes

Multiple combinations for displays self-supporting

Combinazioni multiple per displays autoportanti

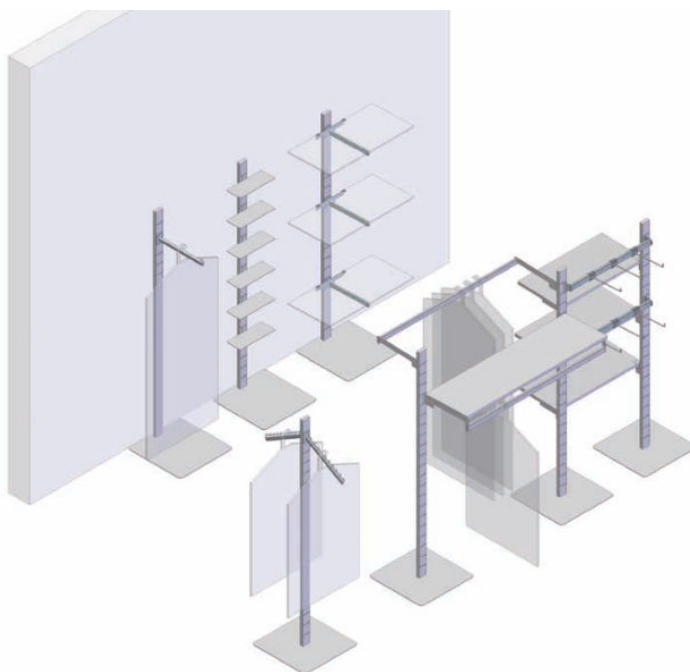

5. Góndola

Multiplas combinaciones para hacer góndolas
Multiples combinaisons pour gondoles
Multiple combinations for gondolas
Combinazioni multiple per gondole

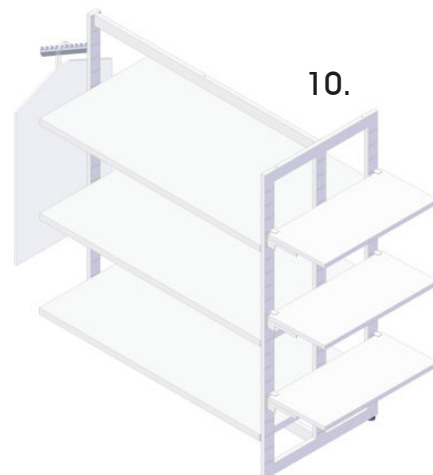
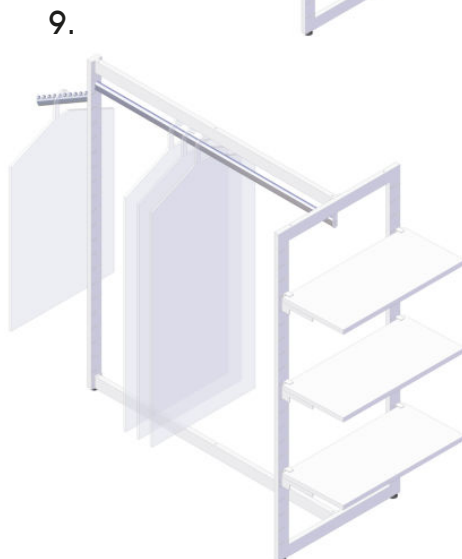
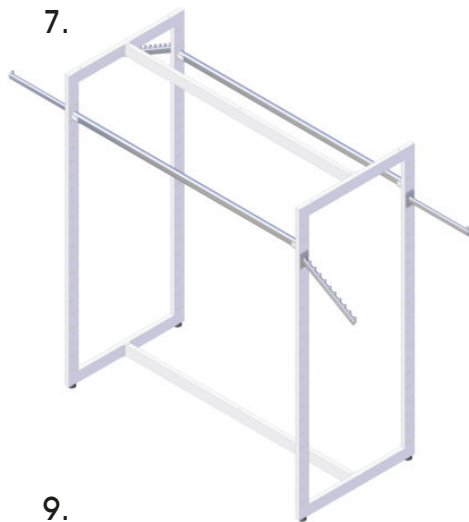
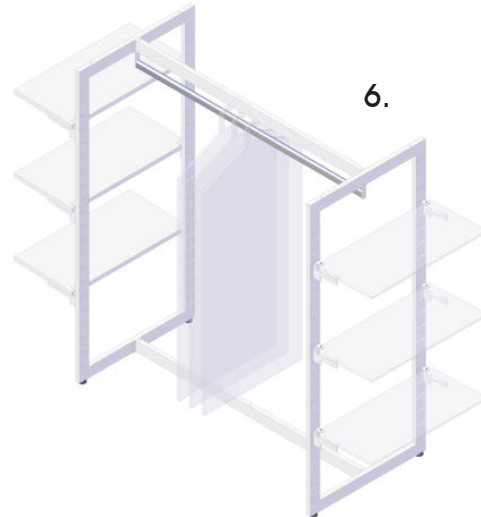

COMPONENTES

BLANCO BLANC WHITE BIANCO	NEGRO NOIR BLACK NERO	COLOR COULEUR COLOR COLORE	ZINCADO PL. ZINK ZINK PL. ZINCATO
OB	ON	OP	34

CR. BRILLO CR. POLI BR. CHR. CR. LUC.	CR. MATE CHR. M M. CHR. CR. OPAC	BLANCO WHITE BIANCO	NEGRO BLACK NERO	COLOR COULEUR COLORE
32	31	OB	ON	OP

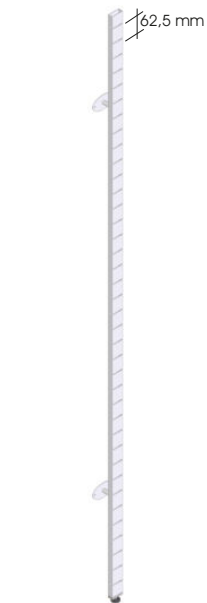

GUÍA CREMALLERA
CRÉMAILLÈRE
UPRIGHT
MONTANTE CREMALLERA
Niveladores a pared y suelo
Niveleurs au mur et au sol
Levellers to wall and floor
Livellatori a muro e suolo
2640/0..

Fe	50x20x2425	€/u
----	------------	-----



TUBO CUELGA
TUBE PENDERIE
TUBE HANGING BAR
TUBO PENDERIA
4547/1..

Fe	3 m	36x18x1,5	€/m
----	-----	-----------	-----



PERROQUET PLANO
PENDERIE FRONTALE
STRAIGHT ARM
APPENDERIA FRONTALE
3019/0..

Fe	∞4547	∅20 30 cm	€/u
----	-------	-----------	-----



PERROQUET INCLINADO
PENDERIE INCLINÉ
SLOPING ARM
APPENDERIA INCL.
8 pins
3022/0..

Fe	∞4547	∅16 30 cm	€/u
----	-------	-----------	-----



GANCHO
CROCHET
HOOK
BARETTA
3014/0.. 25 cm
3020/0.. 20 cm
3021/0.. 10 cm

Fe	∞4547	∅6	€/u
----	-------	----	-----



GANCHO PORTAPRECIO
CROCHET PORTAPRIX
HOOK LABEL-HOLDER
BARETTA PORTAPREZZO
3012/0.. 25 cm

Fe	∞4547	∅6 25 cm	€/u
----	-------	----------	-----



CARTELA ESTANTE MADERA
SUPPORT TABLETTE EN BOIX
BRACKET FOR WOOD SHELF
MENSOLA RIPIANO LEGNO
2630/0.. der.
droite/right/destra
2631/0.. izq.
gauche/left/sinistra

Fe	19 mm	€/u
----	-------	-----



CARTELA ESTANTE VIDRIO
SUPPORT TABLETTE VERRE
BRACKET FOR GLASS SHELF
MENSOLA RIPIANO VETRO
2632/0.. der.
droite/right/destra
2633/0.. izq.
gauche/left/sinistra

Fe	8-10 mm	€/u
----	---------	-----



CARTELA PARA ESTANTE DE MADERA O VIDRIO Y BARRA CONFECCIÓN
SUPPORT BARRE PENDERIE + TABLETTE VERRE ET BOIX
BRACKET FOR HANGING BAR + GLASS OR WOOD SHELF
MENSOLA BARRA APPENDERIA + RIPIANO VETRO O LEGNO
min: 35 cm
2634/0.. der.
droite/right/destra
2635/0.. izq.
gauche/left/sinistra

Fe	∞4547	€/u
----	-------	-----



CARTELA BARRA ACCESORIOS
SUPPORT BARRE ACCESSOIRES
BRACKET FOR ACCESSORIES BAR
MENSOLA BARRA ACCESSORI
2638/0.. der.
droite/right/destra
2639/0.. izq.
gauche/left/sinistra

Fe	∞4547	€/u
----	-------	-----



TORNILLO-EMBELLECEDOR
DISQUE DE FINITION
STUD SCREW
DISCO VITE
4720/0..

Fe	∞4547	€/u
----	-------	-----



PORTAPRECIO
PORTAPRIX
LABEL HOLDER
PORTAPREZZO
382/009

plas	∞3012	50x50	€/u
------	-------	-------	-----



SISTEMA SEGURIDAD GANCHO SENCILLOS
BLOCCAGE
SECURITY LOCK
BLOCCO SICUREZZA
373/00N

plas	∞ max. ∅6	€/u
------	-----------	-----



SISTEMA SEGURIDAD GANCHOS DOBLES
BLOCCAGE
SECURITY LOCK
BLOCCO SICUREZZA
383/00N

plas	∞ max. ∅6	€/u
------	-----------	-----



IMÁN ESPECIAL PARA SISTEMA SEGURIDAD GANCHOS
IMAN DESBLOCCAGE
UNLOCK MAGNET
MAGNETE SBLOCCO
384/000

plas	∞ max. ∅6	€/u
------	-----------	-----

GÓNDOLAS

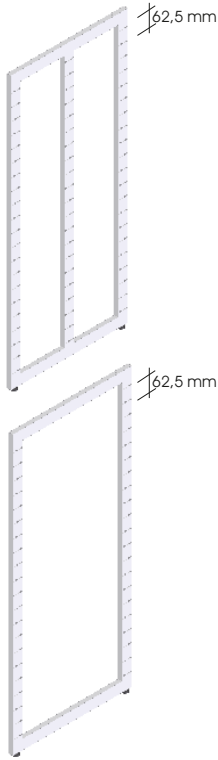

MONTANTE CREMALL. 2 CARAS
CRÉMAILLÈRE 2 CÔTES
2 SIDES GONDOLA UPRIGHT
MONTANTE CREMALLERA 2 LATI
Niveladores suelo
Niveleurs au sol
Floor levellers
Livellatori suolo
*2641/0..

	BLANCO BLANC WHITE BIANCO	NEGRO NOIR BLACK NERO	COLOR COULEUR COLOR COLORE
	OB	ON	OP
Fe 1400x600x20 €/u			
	*o	*o	*o

MONTANTE CREMALL. 2 CARAS
CRÉMAILLÈRE 2 CÔTES
2 SIDES GONDOLA UPRIGHT
MONTANTE CREMALLERA 2 LATI
Niveladores suelo
Niveleurs au sol
Floor levellers
Livellatori suolo
*2644/0..

	BLANCO BLANC WHITE BIANCO	NEGRO NOIR BLACK NERO	COLOR COULEUR COLOR COLORE
	OB	ON	OP
Fe 1400x600x20 €/u			
	*o	*o	*o

MONTANTE CREMALL. 2 CARAS
CRÉMAILLÈRE 2 CÔTES
2 SIDES GONDOLA UPRIGHT
MONTANTE CREMALLERA 2 LATI
Niveladores suelo
Niveleurs au sol
Floor levellers
Livellatori suolo
*2642/0..

	BLANCO BLANC WHITE BIANCO	NEGRO NOIR BLACK NERO	COLOR COULEUR COLOR COLORE
	OB	ON	OP
Fe 1400x50x20 €/u			
	*o	*o	*o

CREMALL. 2 CARAS + BASE
CRÉMAILLÈRE 2 CÔTES + BASE
2 SIDES UPRIGHT + BASE
CREMALLERA 2 LATI + BASE
Base 380x380 mm
Base 380x380 mm
*2648/0..

	BLANCO BLANC WHITE BIANCO	NEGRO NOIR BLACK NERO	COLOR COULEUR COLOR COLORE
	OB	ON	OP
Fe 1400x50x20 €/u			
	*o	*o	*o

CREMALL. 1 CARA + BASE
CRÉMAILLÈRE 1 CÔTES + BASE
1 SIDE UPRIGHT + BASE
CREMALLERA 1 LATO + BASE
Base 380x380 mm
Base 380x380 mm
*2649/0..

	BLANCO BLANC WHITE BIANCO	NEGRO NOIR BLACK NERO	COLOR COULEUR COLOR COLORE
	OB	ON	OP
Fe 1400x50x20 €/u			
	*o	*o	*o

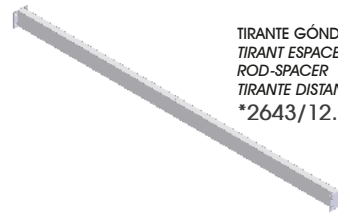

TIRANTE GÓNDOLA
TIRANT ESPACEMENT
ROD-SPACER
TIRANTE DISTANZIATORE
*2643/12. 120 cm

	CR. BRILLO CH.R. POI BR. CH. CR. ILLC.	BLANCO BLANC WHITE BIANCO	NEGRO NOIR BLACK NERO	COLOR COULEUR COLOR COLORE
	32	OB	ON	OP
Fe 50x20 €/u				
	*o	*o	*o	

ACCESORIOS GÓNDOLAS

ACCESOIRES GONDOLA -
GONDOLA ACCESSORIES -
ACCESSORI GONDOLA



SOPORTE CENTRAL
support central
central support
supporto centrale
*2645/0..

	Fe	∅4547	base 40 cm	€/u



SOPORTE ESTANTE
MADERA
SUPPORT TABLETTE BOIX
WOOD SHELF BRACKET
SUPP. RIPIANO LEGNO
*2646/0..

	Fe	base 20 mm	€/u



SOPORTE PENDERIE
A TIRANTE
SUPPORT TUBE PENDERIE
AU TIRANT ESPACEMENT
TUBE SUPPORT
TO ROD-SPACER
SUPPORTO TUBO A
TIRANTE DISTANZIATORE
*2647/0..

	Fe	2643	∅4547	€/u

ACCESORIOS COMUNES MULTILAMAS

ACCESOIRES MULTILAMAS -
MULTILAMAS ACCESSORIES -
ACCESSORI MULTILAMAS

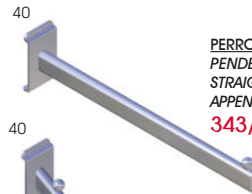

PERROQUET PLANO
PENDERIE FRONTALE
STRAIGHT ARM
APPENDERIA FRONTALE
*343/0..

	Fe	base 40 mm	€/u

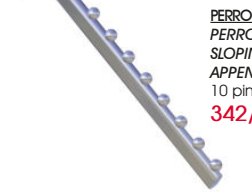

PERROQUET INCLINADO
PERROQUET INCLINÉ
SLOPING ARM
APPENDERIA INCL.
10 pins
*342/0..

	Fe	base 40 mm	€/u

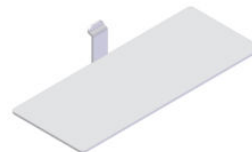

SOPORTE CALZADO
SOUTIEN CHAUSSANT
FOOTWEAR SUPPORT
SUPPORTO CALZATURE
*315/0..

	Fe	250x100 mm	€/u



instal.

OTROS SISTEMAS

SISTEMAS SIN ILUMINACIÓN

STAR 25

COMPONENTES
TUBO OVALADO 36X18
ACCESORIOS TUBO
OVALADO 36X18

STAR 8

SISTEMA ANTIGIRO

CABLE DECO

ÓPTICA

EXPOSITORES PARA GAFAS
OPTI 3
PARALELO 384

JS-25

NUDOS
TUBO 25MM
ACCESORIOS
CARTELAS

STENDERS

PROBADORES

MALLAS

GÓNDOLA EXPOSITOR

BRIDAS

BASIC - LOW COST

BASIC MAXI
BASIC MINI

CONCEPT -LOW COST

STAR 25

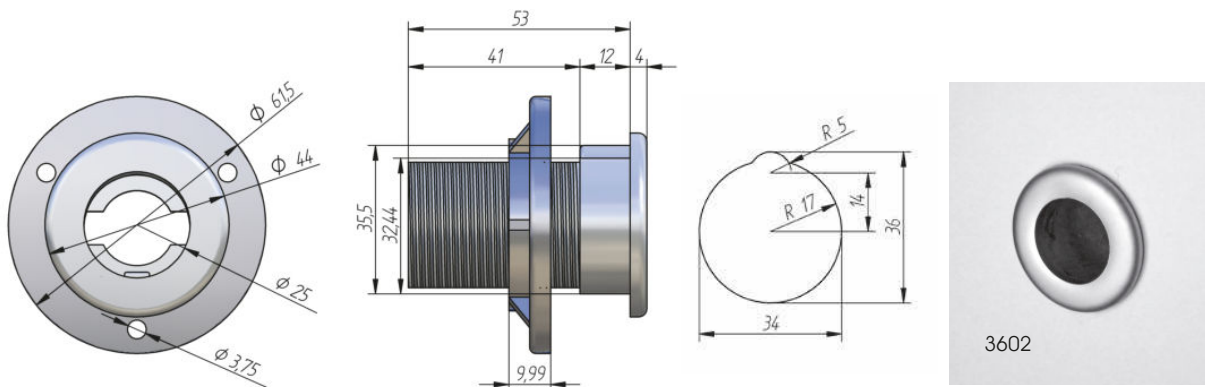

COMPONENTES



CASQUILLO REDONDO Ø44
Accesorios Ø 25 mm
INSERT ROND Ø44
Accessoires Ø25mm
ROUND SOCKET Ø44
Fittings Ø25 mm
BOCCOLA ROTONDA Ø44
Accessori Ø25 mm
3602/0..



CARTELA SUPPORT BRACKET MENSOLA
3620/0..



PERROQUET PLANO PENDIERE FRONTAL STRAIGHT ARM APPENDERIA FRONTALE
3615/0.. 250 cm
3614/0.. 350 cm



PERROQUET INCLINADO PERROQUET INCLINÉE SLOPING ARM APPENDERIA INCLINADA
3617/0..



PERROQUET PLANO 'Z' PENDIERE FRONTAL 'Z' STRAIGHT ARM 'Z' APPENDERIA FRONTALE 'Z'
3616/0..



CARTELA BARRA PENDIERE SUPPORT BARRE PENDIERE BRACKET HANGING BAR MENSOLA APPENDERIA
3618/0..



CARTELA BARRA PENDIERE SUPPORT BARRE PENDIERE BRACKET HANGING BAR MENSOLA APPENDERIA
3619/0..



CARTELA BARRA PENDIERE SUPPORT BARRE PENDIERE BRACKET HANGING BAR MENSOLA APPENDERIA
3619/0..



CARTELA BARRA PENDIERE SUPPORT BARRE PENDIERE BRACKET HANGING BAR MENSOLA APPENDERIA
3619/0..

COLOR COULEUR COLOR COLORE	CR. BRILLO CHR. POLI BR. CHR CR. LUC.	CR. MATE CHR. M M. CHR CR. OPAC
OP	32	31

1x Ø 34 - 1x Ø 10
Zn 13-30 mm
12 kg/u €/u

Fe	Ø25
330 mm	€/u

Fe	Ø25
250 mm	€/u

Fe	Ø25
390 mm	€/u

Fe	Ø25
350 mm	€/u

Fe	Ø25
320 mm	€/u
∅4547(36x18)	

Fe	Ø25
330 mm	€/u
∅4547(36x18)	

COLOR COULEUR COLOR COLORE	CR. BRILLO CHR. POLI BR. CHR CR. LUC.	CR. MATE CHR. M M. CHR CR. OPAC
OP	32	31

Fe	Ø25
∅4547(36x18)	
330 mm	€/u

Fe	Ø25
330 mm	€/u

Fe	1 m
36x18x1,5	€/m

Zn	46x18
∅4547	€/u

Fe	∅4547
300 mm	€/u

Fe	∅ 4547
250 mm	€/u

Fe	∅ 4547
250 mm	€/u

PLÁSTICO PLASTIQUE PLASTIC PLASTICA	NEGRO NOIR BLACK NERO	BRUTO BRUT RAW GREZZO
09	0N	00

plas	40x50 mm	€/u
------	----------	-----

plas	Ø6 mm	€/u
------	-------	-----

plas	Ø6 mm	€/u
------	-------	-----

373-383/00N	€/u
-------------	-----



CARTELA BARRA ACCESORIOS SUPPORT BARRE ACCESSOIRES BRACKET FOR ACCESSORIES ROD MENSOLA TUBO PORTA-ACCESSORI
3609/0..

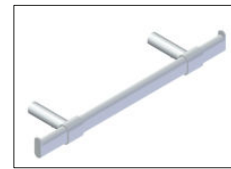

TUBO OVALADO 36X18



TUBO OVAL 36x18 mm TUBE OVALE 36X18 mm OVAL TUBE 36X18 mm TUBO OVALE 36X18 mm
4547/10P PINTADO
4547/132



TAPA FINAL CON TOPE EMBOUT AVEC RETENTION END-CAP WITH STOP COPRITESTA + RETENZIONE
4722/0..

ACCESORIOS TUBO OVALADO 36X18



PERROQUET PLANO PENDIERE FRONTAL STRAIGHT ARM APPENDERIA FRONTALE
3019/0..



GANCHO CROCHET HOOK BARRETTA
3014/0.. 25 cm



GANCHO PORTAPRECIO CROCHET PORTAPRIX HOOK LABEL-HOLDER BARRETTA PORTAPREZZO
3012/0.. 25 cm



PORTAPRECIO PORTAPRIX LABELHOLDER PORTAPREZZO
382/009



BLOQUEO GANCHO BLOCAGE BROCHE HOOK SECURITY LOCK BLOCCO SICUREZZA GANCIO
373/00N



BLOQUEO GANCHO DOBLE BLOCAGE BROCHE DOUBLE DOUBLE HOOK SECURITY LOCK BLOCCO GANCIO DOPPIO
383/00N



IMÁN ESPECIAL DESBLOQUEO UNLOCK MAGNET UNLOCK MAGNET MAGNETE DI SBLOCCO
384/000

STAR 8

SISTEMA ANTIGIRO

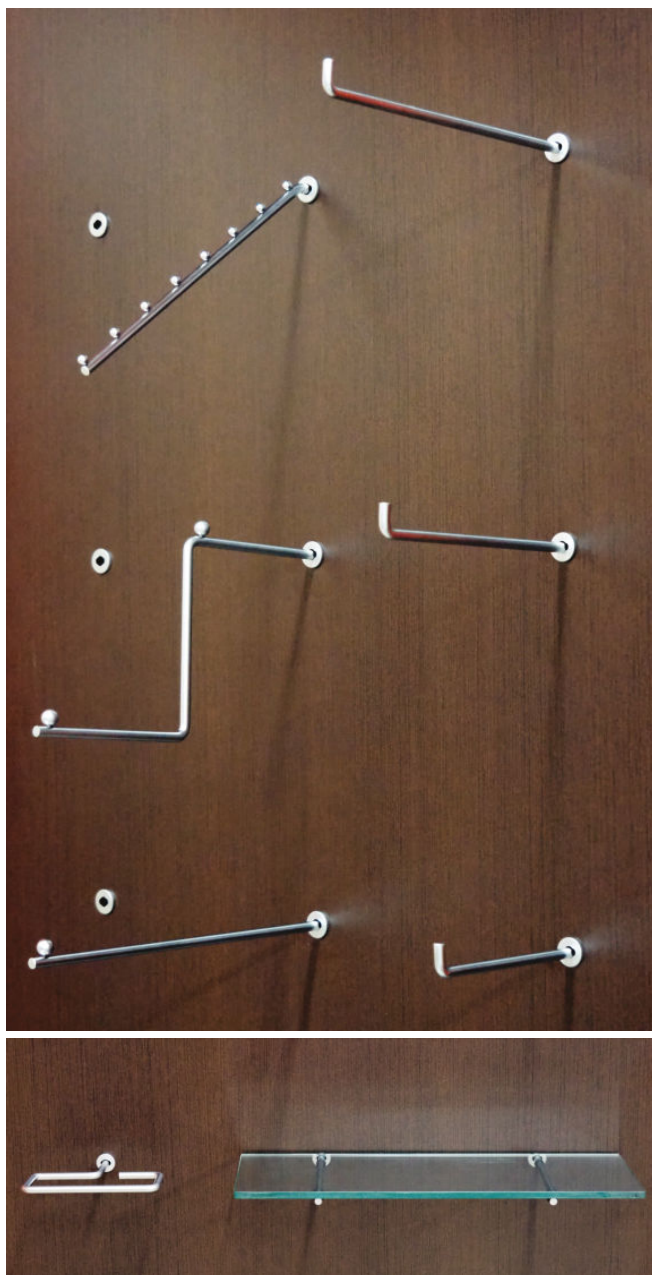

CR. MATE
CHR. M
M. CHR
CR. OPAC
31

CASQUILLO REDONDO Ø22

Accesorios Ø 8 mm
INSERT ROND Ø22
Accessoires Ø8mm
ROUND SOCKET Ø22
Fittings Ø8 mm
BOCCOLA ROTONDA Ø22
Accessori Ø8 mm



Zn	8-22 mm
1x Ø 8 - 1x Ø 4	
12 kg/u	€/u

3604/N31

○

GANCHO

HOOK
BROCHE
BARRETTA



Fe	Ø 8 mm	€/u
----	--------	-----

3605/N31 15 cm

○

3606/N31 20 cm

○

3607/N31 25 cm

○

CARTELA

SUPPORT
BRACKET
MENSOLA



Fe	Ø 8 mm	€/u
----	--------	-----

3627/N31 15 cm

○

3628/N31 25 cm

○

PERROQUET

PERROQUET
ARM
APPENDERIA



Fe	Ø 8 mm	€/u
----	--------	-----

3624/N31 30 cm

○

PERROQUET INCLINADO

PERROQUET INCLINÉE
SLOPING ARM
APPENDERIA INCLINADA

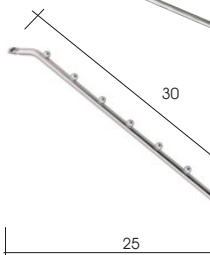

Fe	Ø 8 mm	€/u
----	--------	-----

3625/N31

○

PERROQUET "Z"

PERROQUET "Z"
ARM "Z"
APPENDERIA "Z"

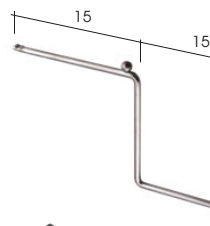

Fe	Ø 8 mm	€/u
----	--------	-----

3629/N31

○

SOPORTE ZAPATO

SUPPORT CHAUSSURE
SHOE SHELF
SUPPORTO SCARPA

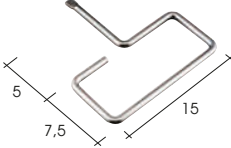

Fe	Ø 8 mm	€/u
----	--------	-----

3623/N31

○

SOPORTE ZAPATO

SUPPORT CHAUSSURE
SHOE SHELF
SUPPORTO SCARPA

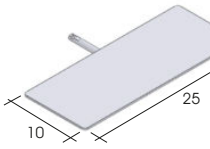

Fe	Ø 8 mm	€/u
----	--------	-----

3630/N31

○

SOPORTE OCULTO

ESTANTE DE MADERA
SUPPORT DISSIMULÉ
ÉTAGÈRE EN BOIS



Fe	175 mm	€/u
----	--------	-----

3631/034

○

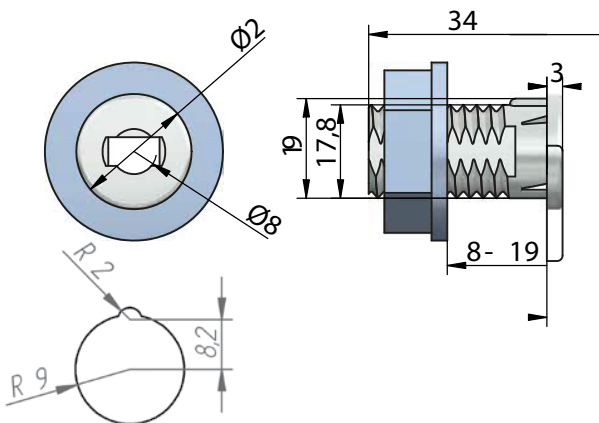

CABLE DECO



ENGANCHE TECHO
ATELAGE PLAFOND
CEILING CONNECTION
AGGANCIO SOFFITTO
3410/032

CR. BRILLO CHR. POLI BR. CHR CR. LUC.	32	
Cu	40kg/u	€/u



ROLLO
50 METROS

CABLE INOX
INOX WIRE
Length: cut to size
CÂBLE INOX
Longueur: coupé à la taille
CAVO INOX
Lunghezza: tagliato a misura
3411/128 VENTA POR METRO
3411/028 VENTA ROLLO 50 M

INOX S.S.	40kg/u	Ø1,5mm	€/m	€/u
--------------	--------	--------	-----	-----



ENGANCHE SUELO CON TENSOR
ATELAGE PAVEMENT
FLOOR CONNECTION
AGGANCIO PAVIMENTO CON TENSOR
3412/032

Cu	€/u
----	-----



ENGANCHE REGULABLE SUELO 180°
ATELAGE RÉGLABLE 180° PAVEMENT
ADJUSTABLE 180° FLOOR CONNECTION
AGGANCIO REGOLABILE 180° PAVIMENTO
3425/032

Cu	€/u
----	-----



PINZA MÓVIL SENCILLA
PINCE SIMPLES MOBILE
SINGLE MOVABLE CLAMP
MORSETTO MOBILE SEMPLICE
3415/032

Cu	4-8 mm	€/u
----	--------	-----



PINZA MÓVIL DOBLE
PINCE DOUBLE MOBILE
DOUBLE MOVABLE CLAMP
MORSETTO MOBILE DOPPIA
3416/032

Cu	4-8 mm	€/u
----	--------	-----



SOPORTE ESTANTE VIDRIO
CON TALADRO Ø14 MM
GLASS SHELF SUPPORT WITH DRILL Ø14 mm
SUPPORT DE TABLETTE AVEC TROU Ø14 mm
SUPPORTO RIPIANO CON FORO Ø14 mm
3417/032

Cu	Ø 14 mm	€/u
----	---------	-----



SOPORTE ESTANTE MADERA
CON TALADRO
SUPPORT DE TABLETTE AVEC TROU
GLASS SHELF SUPPORT WITH DRILL
SUPPORTO RIPIANO CON FORO
3418/032

Cu	€/u
----	-----



PIEZA SEGURIDAD
PIECE DE SÉCURITÉ
SECURITY PIECE
PEZZO DI SICUREZZA
3426/022

INOX	€/u
------	-----



COLGADOR CUADROS
HANGER PICTURES
ANCRER POUR ACCROCHER TABLEAUX
AGGANCIO PER APPENDERE QUADRI
3419/032

CR. BRILLO CHR. POLI BR. CHR CR. LUC.	32
Cu	€/u

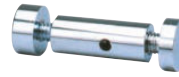

SOPORTE CUADRO CON TALADRO
FRAME SUPPORT WITH DRILL
SUPPORT TABLEAU AVEC TROU
SUPPORTO PER QUADRO CON FORO
3420/032

Cu	€/u
----	-----



ANCLAJE PESTAÑA ESTANTE INCLINADO
SUPPORT ONGLET TABLETTE INCLINÉE
TAB ANCHOR FOR INCLINED SHELF
ANCORAGGIO BORDO RIPIANO INCLINATO
*3421/032

Cu	€/u
----	-----



BARRA
2 METROS

CARRIL PARA COLGAR A TECHO O
A PARED.
PROFIL POUR ACCROCHER AU PLAFOND
OU AU MUR
TRACK TO HANG ON THE CEILING
OR WALL
PROFILO DA APPENDERE A SOFFITTO
O PARETE
3422/201

Al	€/u
----	-----



ENGANCHE CABLE A CARRIL 3422
CÂBLE ATELAGE A LE PROFIL 3422
WIRE/TRACK 3422 JOINT
AGGANCIO CAVO AL PROFILO 3422
*3427/032

Cu	€/u
----	-----



ANCLAJE PARA COLGAR CUADROS
A TECHO O PARED
ANCRER POUR ACCROCHER TABLEAUX
AU PLAFOND OU AU MUR
HOOK FOR HANGING PICTURES
ON THE WALL OR CEILING
AGGANCIO PER APPENDERE QUADRI
ALLA PARETE O AL SOFFITTO
3423/032

Cu	€/u
----	-----



ANCLAJE PARA COLGAR CUADROS
A TECHO, PARED Y COLUMNAS KADÍ
ANCRER POUR ACCROCHER TABLEAUX AU
PLAFOND, AU MUR OU COLUMNS KADÍ
HOOK FOR HANGING PICTURES ON THE
WALL, CEILING OR KADÍ COLUMNS
AGGANCIO PER APPENDERE QUADRI ALLA
PARETE, AL SOFFITTO O COLONNE KADÍ
3424/032

Cu	€/u
----	-----

3426
Pieza de seguridad.
Evita que la balda se salga
por la parte superior.

3418
Pieza de anclaje.
Se encastra a la madera
para anclar en el punto
deseado del cable.

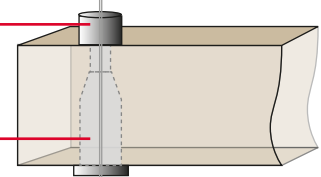

ÓPTICA

Con ó sin cerradura (misma llave)
Ganchos de acero

PRÉSENTOIRS POUR LUNETTES
Avec ou sans serrure (même combinaison)
Crochets en acier inoxydable

DISPLAYS FOR GLASSES
With or without lock (keyed alike)
Wire in stainless steel

DISPLAYS PER OCCHIALI
Con o senza serratura (stessa combinazione)
Ganci in acciaio inox

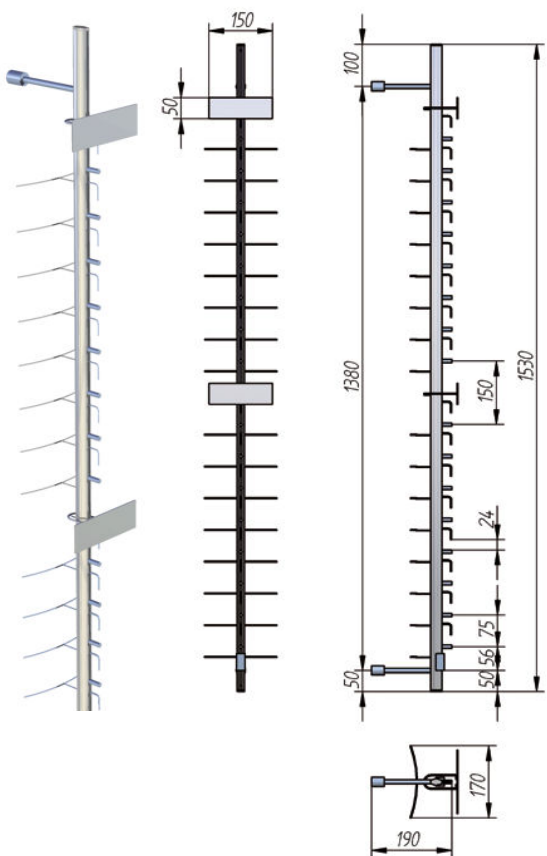

BARRA PARED 8+8 CON CERRADURA
16 gafas - distancia gafas 750 mm
PRÉSENTOIR MURAL 8+8 AVEC SERRURE
16 lunettes - Distance lunettes: 75 mm
WALL DISPLAY 8+8 WITH LOCK
16 glasses - Distance glasses: 75 mm
DISPLAY PARETE 8+8 CON SERRATURA
16 occhiali - Distanza occhiali: 75 mm

2585/001

2 PORTARÓTULOS INCLUIDOS
2 support-étiquettes inclus
2 brand holders included
2 supporti logo inclusi

PL. MATE ALU. MAT ALU. MATT ALL. NATURALE	
01	
Al	inox s.s.
153 cm	€/u

PORTARÓTULO NO INCLUIDOS
support-étiquettes non inclus
brand holder not included
supporto logo non inclusi

EXPOSITORES PARA GAFAS

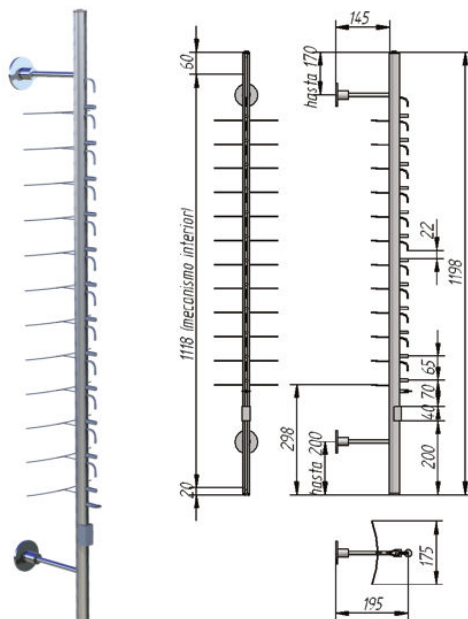

BARRA PARED CON CERRADURA 120 cm
12 gafas - distancia gafas 70 mm
PRÉSENTOIR MURAL AVEC SERRURE 120 cm
12 lunettes - Distance lunettes: 65 mm
WALL DISPLAY WITH LOCK 120 cm
12 glasses - Distance glasses: 65 mm
DISPLAY PARETE CON SERRATURA 120 cm
12 occhiali - Distanza occhiali: 65 mm

2595/001

PL. MATE ALU. MAT ALU. MATT ALL. NATURALE	
01	
Al	inox s.s.
120 cm	€/u

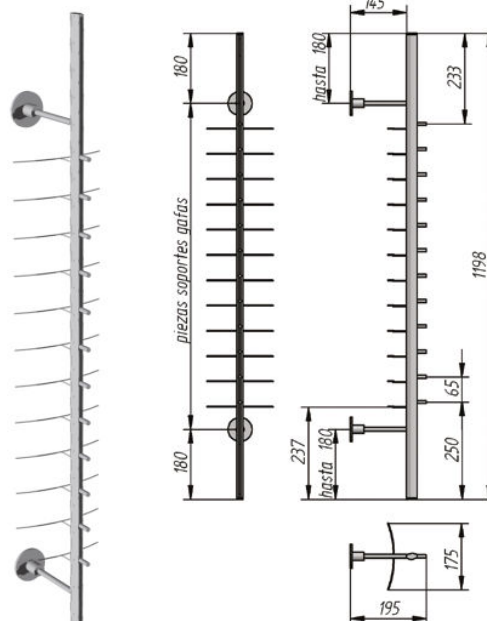

BARRA PARED SIN CERRADURA 120 cm
12 gafas - distancia gafas 65 mm
PRÉSENTOIR MURAL SIN SERRURE 120 cm
12 lunettes - Distance lunettes: 65 mm
WALL DISPLAY WITHOUT LOCK 120 cm
12 glasses - Distance glasses: 65 mm
DISPLAY PARETE SENZA SERRATURA 120 cm
12 occhiali - Distanza occhiali: 65 mm

2591/001

PL. MATE ALU. MAT ALU. MATT ALL. NATURALE	
01	
Al	inox s.s.
120 cm	€/u

PORTARÓTULO NO INCLUIDOS
support-étiquettes non inclus
brand holder not included
supporto logo non inclusi

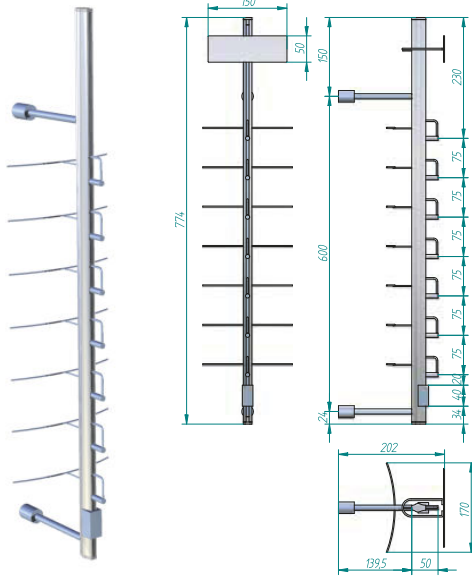

BARRA PARED CON CERRADURA 77,4 cm
7 gafas - distancia gafas 75 mm

PRÉSENTOIR MURAL AVEC SERRURE 77,4 cm
7 lunettes - Distance lunettes: 75 mm

WALL DISPLAY WITH LOCK 77,4 cm
7 glasses - Distance glasses: 75 mm

DISPLAY PARETE CON SERRATURA 77,4 cm
7 occhiali - Distanza occhiali: 75 mm

*2597/001

PORTARÓTULO NO INCLUIDOS
support-étiquettes non inclus
brand holder not included
supporto logo non inclusi



PORTARÓTULO pintado en gris
SUPPORTÉTIQUETTE peint en gris
BRAND HOLDER painted gray
SUPPORTO LOGO verniciato grigio

2584/00M

PL. MATE
ALU. MAT
ALU. MATT
ALL. NATURALE

01

Al	Inox	€/u
	s.s.	
		77,4 cm

*o

Fe	150x50 mm	€/u
		∞ 2591-2594-2595-2597

o

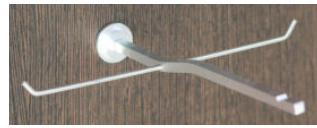

SOPORTE GAFAS PANEL

Se fija por detrás o delante
SUPPORT LUNETTES AU PANNEAU
Fixé de derrière le panneau
GLASSES SUPPORT TO PANEL
Fixed from behind the panel
SUPPORTO OCCHIALI A PANNELLO
Fissato da dietro

2593/001

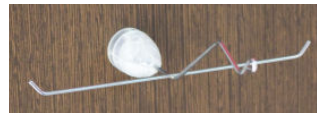

SOPORTE GAFAS PANEL

Se fija por delante
SUPPORT LUNETTES AU PANNEAU
Fixé devant le panneau
GLASSES SUPPORT TO PANEL
Fixed in front of the panel
SUPPORTO OCCHIALI A PANNELLO
Fissato da davanti

2592/032

PL. MATE
ALU. MAT
ALU. MATT
ALL. NATURALE

01

Al	€/u
----	-----

172x170 mm

o

CR. BRILLO
CH-R. POLI
BR. CH-R
CR. LUC.

32

Al	€/u
----	-----

180x190 mm

o

OPTI-3



PERFIL INVISIBLE PARA ESTANTES
DE 3 MM DE ESPESOR

PROFIL INVISIBLE POUR ÉTAGÈRES
3 MM D'ÉPAISSEUR
INVISIBLE PROFILE FOR SHELVES
3 MM THICK
PROFILO INVISIBLE PER RIPIANI DI
3 MM DI SPESSORE

360/1..

Al	5 m	€/m
	6/8 mm	

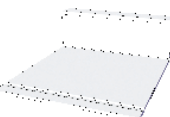

SUPPORT-TABLETTE 3MM
FOLDED BRACKET-SHELF 3 MM
MENSOLA-RIPIANO PIEDATA 3 MM

387/0.. 190MM

(POSIBILIDAD DE CORTE A MEDIDA BAJO PEDIDO)

Al	190x190x50 mm	€/u
----	---------------	-----



ESTANTE 3 MM
SUPPORT-TABLETTE 3MM
BRACKET-SHELF 3 MM
MENSOLA-RIPIANO 3 MM

388/0..

Fe	€/u
----	-----

190x190 mm

EXPOSITOR PARA FONDO DE
METACRILATO

PRÉSENTOIR POUR FOND MÉTHACRYLATE
DISPLAY FOR PLEXIGLASS BACK
DISPLAY PER FONDO IN PLEXIGLASS

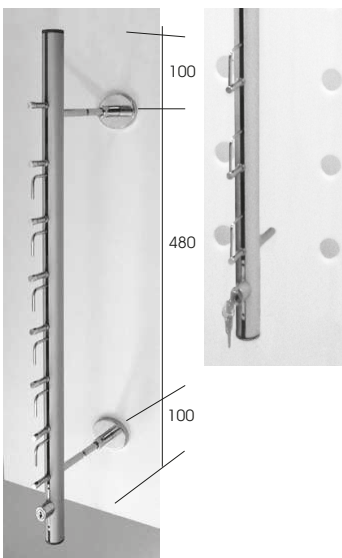

EJEMPLO DE APLICACION CON PANEL
RETROILUMINADO Y AGUJEREO
PARA APOYAR LAS GAFAS

EXEMPLE D'APPLICATION AVEC PANNEAU
RÉTROÉCLAIRÉ ET TROUS
POUR SOUTENIR LES LUNETTES
APPLICATION EXAMPLE WITH BACKLIT
PANEL WITH HOLES WITH HOLES AS
GLASSES SUPPORT

ESEMPIO D'APPLICAZIONE CON PANNELLO
RETROILLUMINATO E FORI
COME SUPPORTO OCCHIALI

EXPOSITOR SIN
REJILLA POSTERIOR
6 gafas con cerr. +
2 gafas sin cerr.
distancia gafas 70 mm

PRÉSENTOIR MURAL
SANS SUPPORT DARRIÈRE
6 lunettes avec serrure et 2 sans -
Distance lunettes: 70 mm

WALL DISPLAY WOTHOUT BACK SUPPORT
6 glasses with lock and 2 without -
Distance glasses: 70 mm

DISPLAY PARETE SENZA SUPPORTO RETRO
6 occhiali con serratura e 2 senza -
Distanza occhiali: 70 mm

*2586/001

Al	Inox	€/u
	s.s.	
	68 cm	

*o

PARALELO 384

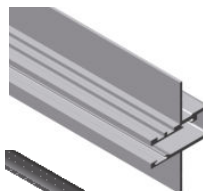

PERFIL INVISIBLE
PROFIL D'ALUMINIUM
ALUMINIUM PROFILE
PROFILO DI ALLUMINIO

384/1..

Al	5 m	€/m
	∞ 384/1181	5/6/8 mm



GOMA DURA
CAOUTCHOUC DUR
HARD RUBBER
GOMMA DURA

384/109

plac	∞ 384	€/m
------	-------	-----



GANCHO GAFAS
SUPPORT POUR LUNETTES
SUPPORT FOR GLASSES
BARRETTA PER OCCHIALI

*379/0..

Fe	€/u
----	-----

*o

SISTEMA JS-25



COMPONENTES

NUDOS



NUDO 3 SALIDAS
JOINT À 3 VOIES
3 WAY JOINT
GIUNTO 3 VIE
150/0..



NUDO 4 SALIDAS
JOINT À 4 VOIES
4 WAY JOINT
GIUNTO 4 VIE
151/0..



NUDO 4 SALIDAS
JOINT À 4 VOIES
4 WAY JOINT
GIUNTO 4 VIE
151/E..



NUDO 4 SALIDAS EN CRUZ
JOINT À 4 VOIES À CROIX
4 WAY CROSS-JOINT
GIUNTO 4 VIE A CROCE
152/0..



NUDO 5 SALIDAS
JOINT À 5 VOIES
5 WAY JOINT
GIUNTO 5 VIE
153/0..



NUDO 5 SALIDAS
JOINT À 5 VOIES
5 WAY JOINT
GIUNTO 5 VIE
153/L..



NUDO 5 SALIDAS
JOINT À 5 VOIES
5 WAY JOINT
GIUNTO 5 VIE
153/E..



NUDO PARALELO DOBLE
JOINT À 2 VOIES PARALLÈLES
2 PARALLEL WAY JOINT
GIUNTO 2 VIE PARALLELE
154/0..



NUDO PARALELO TRIPLE
JOINT À 3 VOIES PARALLÈLES
3 PARALLEL WAY JOINT
GIUNTO 3 VIE PARALLELE
*155/0..



NUDO 6 SALIDAS
JOINT À 2 VOIES
2 WAY JOINT
GIUNTO 2 VIE
156/0..



NUDO 6 SALIDAS
JOINT À 2 VOIES
2 WAY JOINT
GIUNTO 2 VIE
156/E..



BRIDA ESPEJOS
BRIDE MIROIRS
CLAMP MIRRORS
GIUNTO PER SPECCHIO
*159/0..

CR. BRILLO	CR. ORO	BLANCO	NEGRO	COLOR
CR. POLI	CR. DOR	BLANC	NOIR	COULEUR
BR. CHR.	GOLD. C	WHITE	BLACK	COLOR
CR. LUC.	CR. ORO	BANCO	NERO	COLORE
32	33	0B	0N	0P

RAL 9006 = color 0P
metal. OM= 032+50%

Al	Ø25	∞203	€/u
----	-----	------	-----

Al	Ø25	∞203	€/u
----	-----	------	-----

Al	Ø25	∞203	€/u
----	-----	------	-----

Al	Ø25	∞203	€/u
----	-----	------	-----

Al	Ø25	∞203	€/u
----	-----	------	-----

Al	Ø25	∞203	€/u
----	-----	------	-----

Al	Ø25	∞203	€/u
----	-----	------	-----

Al	Ø25	∞203	€/u
----	-----	------	-----

Al	Ø25	∞203	€/u
----	-----	------	-----

Al	Ø25	∞203	€/u
----	-----	------	-----

Al	Ø25	∞203	€/u
----	-----	------	-----

Al	Ø25	∞203	€/u
----	-----	------	-----

Al	Ø25	∞203	€/u
----	-----	------	-----

TUBO Ø25MM



TUBO Ø 25 mm
TUBE Ø 25 mm
TUBE Ø 25 mm
TUBO Ø 25 mm

203/3.. 300 cm

Fe	3 m	€/u
----	-----	-----

ACCESORIOS



SOPORTE ABIERTO AJUSTABLE TUBO Ø25
TUBE DE SUPPORT OUVERT RÉGLABLE Ø25
ADJUSTABLE OPEN SUPPORT TUBE Ø25
SUPPORTO APERTO REGOLABILE TUBO Ø25
220/032

Al	Ø25	∞203	€/u
----	-----	------	-----



SOPORTE CERRADO AJUSTABLE TUBO Ø25
TUBE DE SUPPORT FERMÉ RÉGLABLE Ø25
ADJUSTABLE CLOSED SUPPORT TUBE Ø25
SUPPORTO CHIUSO REGOLABILE TUBO Ø25
221/032

Al	Ø25	∞203	€/u
----	-----	------	-----



ANILLO DE FIJACION A PARED
ANNEAU DE FIXATION MURALE
WALL FIXING RING
GHIERA DI FISSAGGIO A PARETE
225/0..

Al	Ø25	∞203	€/u
----	-----	------	-----



TAPÓN PARA TUBO
BOUCHON POUR TUBE
TUBE CAP
TAPPO PER TUBO
236/032

Al	Ø25	∞203	€/u
----	-----	------	-----



NIVELADOR TECHO
VÉRIN SUPÉRIEURE (sol-plafond)
UPPER LEVEL (floor-ceiling)
LIVELLATORE SUPERIORE (suolo-soffitto)
228/0..

Fe	Ø25	€/u
----	-----	-----



NIVELADOR SUELO
VÉRIN INFÉRIEUR (sol-plafond)
LOWER LEVEL (floor-ceiling)
LIVELLATORE INFERIORE (suolo-soffitto)
229/0..

Fe	Ø25	€/u
----	-----	-----



RUEDA + CASQUILLO Ø25
ROUE + JOINT Ø25
CASTOR + JOINT Ø25
ROUTA + GIUNTO Ø25
232/01N

plas	M8 Ø50	30kg/u	€/u
------	--------	--------	-----

CARTELAS



CARTELA FINAL
SUPPORT FINAL
FINAL BRACKET
MENSOLA FINALE
163/0..

Fe	300-350 mm Ø25	consultar medida	€/u
----	----------------	------------------	-----



CARTELA CENTRALE
SUPPORT CENTRAL
CENTRAL BRACKET
MENSOLA CENTRALE
165/0..

Fe	300-350 mm Ø25	consultar medida	€/u
----	----------------	------------------	-----

STENDERS



UNIVERSAL 1 m
altura regulable
extensión lateral
alto: 130/210 cm
largo: 100/160 cm
tubo de 28 mm
rueda d.65 mm
PORTANT UNIVERSEL 100 cm
UNIVERSAL FASHION RACK 100 cm
STAENDER UNIVERSALE 100 cm
26/032

CR. BRILLO	CHR. POLI	BR. CHROME	CR. LUCIDO
32			
Fe	↔100/160 cm		
⌀	130/210 cm	€/u	



UNIVERSAL 1.4 m
altura regulable
extensión lateral
alto: 130/210
largo: 140/200
tubo de 28 mm
rueda D.50 mm
PORTANT UNIVERSEL 140 cm
UNIVERSAL FASHION RACK 140 cm
STAENDER UNIVERSALE 140 cm
28/032

Fe	↔140/200 cm		
⌀	130/210 cm	€/u	



UNIVERSAL DOBLE 1.4 m
altura regulable
extensión lateral
alto: 130/210
largo: 140/200
tubo de 28 mm
PORTANT DOUBLER UNIVERSEL 140 cm
UNIVERSAL FASHION DOUBLE RACK 140 cm
STAENDER DOPPIO UNIVERSALE 140 cm
29/032

Fe	↔140/200 cm		
⌀	130/210 cm	€/u	



25 Ø



***BANDEJA:
VENTA POR
SEPARADO**



PROBADORES

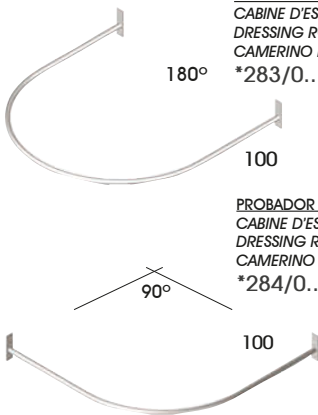

PROBADOR ISLA
CABINE D'ESSAYAGE
DRESSING ROOM
CAMERINO PROVA
***283/0..**

PROBADOR RINCÓN
CABINE D'ESSAYAGE
DRESSING ROOM
CAMERINO PROVA
***284/0..**

CR. BRILLO	BLANCO	NEGRO	COLOR
CHR. POLI	BLANC	NOIR	COULEUR
BR. CHR.	WHITE	BLACK	COLOR
CR. LUC.	BIANCO	NERO	COLORE
32	OB	ON	OP

Fe	€/u
100x100 cm	

Fe	€/u
100x100 cm	



STENDER PEQUEÑO
STENDER PETIT
STENDER SMALL
STAENDER PICCOLO
31/0..

Fe	40 kg	↔70 cm
⌀150 cm €/u		



STENDER MEDIANO
STENDER MOYEN
STENDER MEDIUM
STAENDER MEDIUM
32/0..

Fe	40 kg	↔100 cm
⌀150 cm €/u		



STENDER GRANDE
STENDER GRAND
STENDER LARGE
STAENDER GRANDE
33/0..

Fe	40 kg	↔140 cm
⌀150 cm €/u		



BANDEJA
STENDER GRAND
STENDER LARGE
STAENDER GRANDE
38/0..

Fe	15 kg
30x38x2,5 cm €/u	

MALLAS

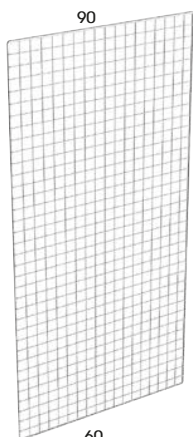

MALLA 180 X 90 cm
GRILL PANEL 1800x900 mm
PANNEAU À GRILLE 1800x900 mm
PANNELLO GRIGLIATO 1800x900 mm
*175/0..

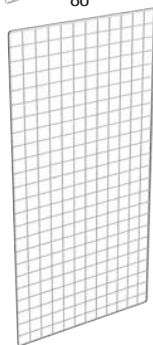

MALLA 120 X 60 cm
GRILL PANEL 1200x600 mm
PANNEAU À GRILLE 1200x600 mm
PANNELLO GRIGLIATO 1200x600 mm
*178/0..

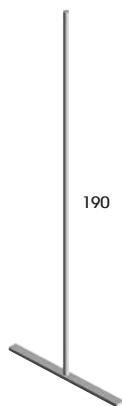

GÓNDOLA-EXPOSITOR

PIE GÓNDOLA CON RUEDA 232
GONDOLA SELF-SUPPORTING UPRIGHT
Castor Ø50 mm included
GONDOLA MONTANT AUTO-PORTANT
Roue Ø50 mm inclus
MONTANTE GONDOLA
Ruota Ø50 mm inclusa
*322/0..

PIE GÓNDOLA CON NIVELADOR 231
GONDOLA SELF-SUPPORTING UPRIGHT
Levellers included
GONDOLA MONTANT AUTO-PORTANT
Vérin inclus
MONTANTE GONDOLA
Piedino livellatore incluso
*324/0..

BRIDAS



SOPORTE MALLA PARED
WALL SUPPORT FOR GRILL PANEL
SUPPORT A MUR POUR PANNEAU
À GRILLE
SUPPORTO A PARETE PER PANNELLO
GRIGLIATO
*185/X..



BRIDA Ø10/Ø10 mm
CLAMP Ø10/Ø10 mm
ETAU Ø10/Ø10 mm
MORSETTO Ø10/Ø10 mm
*187/X..



BRIDA Ø25/Ø10 mm
CLAMP Ø25/Ø10 mm
ETAU Ø25/Ø10 mm
MORSETTO Ø25/Ø10 mm
*186/0..

CR. BRILLO	BLANCO	NEGRO	COLOR
CR. POLI	BLANC	NOIR	COULEUR
BR. CHR	WHITE	BLACK	COLOR
CR. LUC.	BIANCO	NERO	COLORE

32	OB	ON	OP
RAL 9006 = color OP			
metal. 0M= 032+50%			
Fe	180x90 cm	50x50	€/u

Fe	120x60 cm	50x50	€/u
----	-----------	-------	-----

ACCESORIOS



GANCHO
CROCHET
HOOK
BARRETTA
*335/X32 10 cm

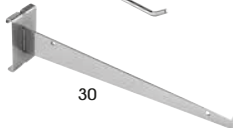

CARTELA ESTANTE MADERA
SUPPORT TABLET BOIS
WOOD SHELF BRACKET
MENSOLA RIPIANO LEGNO
*318/X..

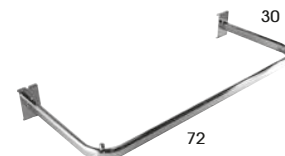

BARRA PENDERIE
BARRE PENDERIE
HANGING BAR
BARRA APPENDERIA
*325/0..

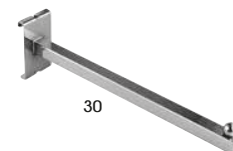

PERROQUET PLANO
PENDERIE FRONTAL
STRAIGHT ARM
APPENDERIA FRONTALE
*339/0..



CESTA REJILLA
GRID BASKET
PANIER DE GRILLE
CESTINO GRIGLIA
*345/0..

CR. BRILLO	BLANCO	NEGRO	COLOR
CR. POLI	BLANC	NOIR	COULEUR
BR. CHR	WHITE	BLACK	COLOR
CR. LUC.	BIANCO	NERO	COLORE

32	OB	ON	OP
Fe			
€/u			

Fe	300 mm	€/u
----	--------	-----

Fe	72x35 cm	€/u
12 kg/u		

Fe	300 mm	€/u
----	--------	-----

Fe	600x310 mm	€/u
----	------------	-----

BASIC LOW COST



BASIC MAXI

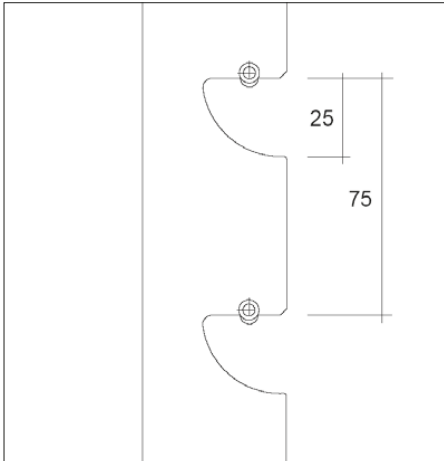

BASIC MINI

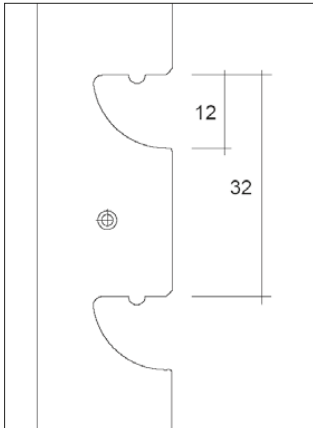
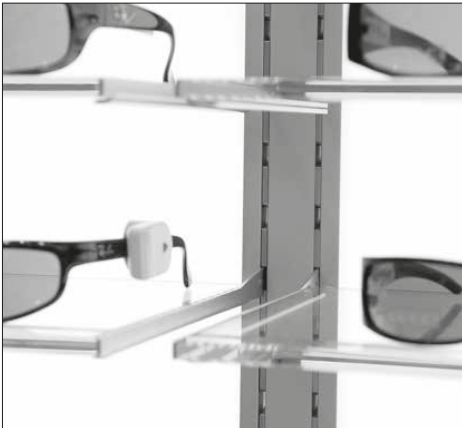

BASIC MAXI

INOX SAT
INOX SAT
S.S.S.
INOX SAT
28

INOX SAT
INOX SAT
S.S.S.
INOX SAT
28

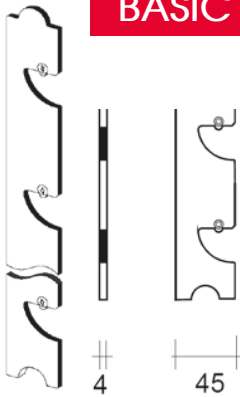

GUÍA CREMALLERA 1 CANAL
CRÉMAILLÈRE
RACK
CREMAGUERA
*2500/028 derecha
droite/right/destra
*2501/028 izquierda
gauche/left/sinistra

inox s.s. 1200 mm
45x4 €/u

*O

*O

25
25

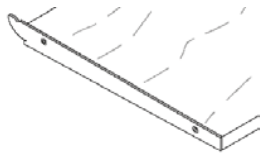

CARTELA ESTANTE MADERA
SUPPORT TABLETTES BOIS
WOOD SHELF BRACKET
MENSOLA RIPIANO LEGNO
*2508/028 derecha
droite/right/destra
*2509/028 izquierda
gauche/left/sinistra

inox s.s. 25 mm
305 mm €/u

*O

*O

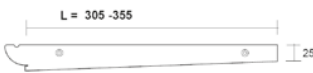

CARTELA ESTANTE MADERA
SUPPORT TABLETTES BOIS
WOOD SHELF BRACKET
MENSOLA RIPIANO LEGNO
*2510/028 derecha
droite/right/destra
*2511/028 izquierda
gauche/left/sinistra

inox s.s. 25 mm
355 mm €/u

*O

*O



CARTELA SUPPORT BRACKET MENSOLA
*2514/028 derecha
droite/right/destra
*2515/028 izquierda
gauche/left/sinistra

inox s.s. 355 mm €/u
∅ 2551-2550

*O

*O



CARTELA INTERMEDIA SUPPORT INTERMEDIAIRE INTERMEDIATE BRACKET MENSOLA INTERMEDIA
*2516/028

inox s.s. 305 mm €/u
∅ 2551-2550

*O

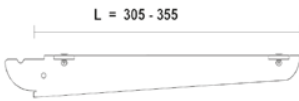

CARTELA INTERMEDIA SUPPORT INTERMEDIAIRE INTERMEDIATE BRACKET MENSOLA INTERMEDIA
*2518/028

inox s.s. 355 mm €/u
2514-2515 ∅ 2551-2550 (x2)

*O



CARTELA INCLINADA 30° SUPPORT INCLINÉE 30° SLOPPING BRACKET 30° MENSOLA INCLINATA 30°
*2520/028 derecha
droite/right/destra
*2521/028 izquierda
gauche/left/sinistra

inox s.s. 25 mm
355 mm €/u

*O

*O

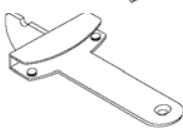

CARTELA ESTANTE VIDRO SUPPORT TABLETTES VERRE GLASS SHELF BRACKET MENSOLA RIPIANO VETRO
*2527/028

inox s.s. 8 mm
105 mm €/u

*O

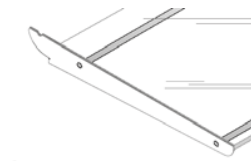
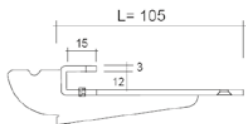

CARTELA ESTANTE VIDRO SUPPORT TABLETTES VERRE GLASS SHELF BRACKET MENSOLA RIPIANO VETRO
*2524/028 derecha
droite/right/destra
*2525/028 izquierda
gauche/left/sinistra

inox s.s. 8 mm
355 mm €/u
∅ 2551-2550 (x2)

*O

*O



CARTELA INTERMEDIA SUPPORT INTERMEDIAIRE INTERMEDIATE BRACKET MENSOLA INTERMEDIA
*2526/028

inox s.s. 8 mm
355 mm €/u
2524-2525 ∅ 2551-2550 (x2)

*O

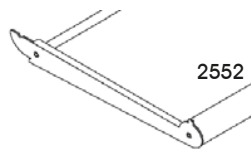

CARTELA BARRA PENDERIE SUPPORT BARRE PENDERIE BRACKET HANGING BAR MENSOLA APPENDERIA
*2528/028 derecha
droite/right/destra
*2529/028 izquierda
gauche/left/sinistra

inox s.s. 300 mm €/u
∅ 2551-2550, 2552-2553

*O

*O

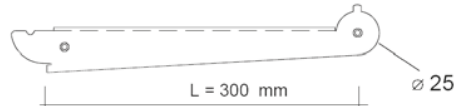

2528-2529 ∅ 2551-2550, 2552-2553

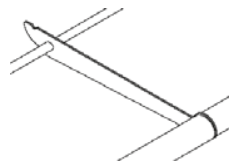

CARTELA INTERMEDIA SUPPORT INTERMEDIAIRE INTERMEDIATE BRACKET MENSOLA INTERMEDIA
*2530/028

inox s.s. 305 mm €/u

*O

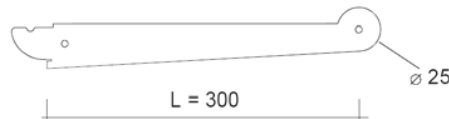

CARTELA + BARRA PENDERIE SUPPORT + BARRE PENDERIE BRACKET + HANGING BAR MENSOLA + APPENDERIA
*2532/028 derecha
droite/right/destra
*2533/028 izquierda
gauche/left/sinistra

inox s.s. 300 mm €/u
∅ 2551-2550, 2552-2553

*O

*O

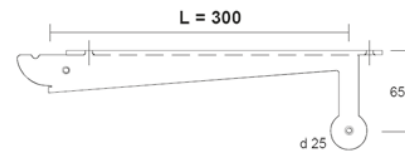
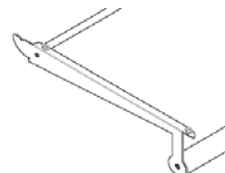

VENTOSA VENTOUSE SUCTION VENTOSA
2556/009

plas Ø14 €/u

O

	INOX SAT INOX SAT S.S.S. INOX SAT 28
	2532-2533 ∞ 2551-2550, 2552-2553
<p>CARTELA INTERMEDIA SUPPORT INTERMEDIAIRE INTERMEDIATE BRACKET MENSOLA INTERMEDIA *2534/028</p>	INOX S.S. 300 mm €/u
<p>BARRA TELESCÓPICA PENDERIE BARRÉ TELESCOPIQUE PENDERIE TELESCOPIC HANGING BAR BARRA TELESCOPICA APPENDERIA *2536/028</p>	INOX S.S. 380+200 mm €/u ∞ 2528-2529-2530
<p>BARRA TELESCÓPICA PENDERIE BARRÉ TELESCOPIQUE PENDERIE TELESCOPIC HANGING BAR BARRA TELESCOPICA APPENDERIA *2537/028</p>	INOX S.S. €/u 380 + 200 mm ∞ 2532-2533-2534
<p>PERROQUET PLANO PENDERIE FRONTAL STRAIGHT ARM APPENDERIA FRONTALE *2538/028</p>	INOX S.S. 300 mm €/u
<p>PERROQUET INCLINADO 30° PERROQUET INCLINÉE 30° SLOPING ARM 30° APPENDERIA INCLINADA 30° *2539/028</p>	INOX S.S. 300 mm €/u
<p>PERROQUET PLANO "Z" PENDERIE FRONTAL "Z" STRAIGHT ARM "Z" APPENDERIA FRONTALE "Z" *2540/028</p>	INOX S.S. 300 mm €/u
<p>GANCHO CROCHET HOOK BARRETTA *2541/028</p>	INOX S.S. 200 mm €/u ∞ 2554 (30x15)

	INOX SAT INOX SAT S.S.S. INOX SAT 28
	INOX S.S. 300 mm €/u ∞ 2554 (30x15)
<p>PERROQUET INCLINADO PERROQUET INCLINÉE SLOPING ARM APPENDERIA INCLINADA *2543/028</p>	INOX S.S. 25 mm €/u ∞ 2554 (30x15)
<p>CARTELA BARRA ACCESORIOS SUPPORT BARRÉ ACCESSOIRES BRACKET FOR ACCESSORIES ROD MENSOLA TUBO PORTA-ACCESSORI *2546/028 derecha droite/right/destra *2547/028 izquierda gauche/left/sinistra</p>	INOX S.S. 50 mm €/u
<p>PORTARÓTULO SUPPORTÉTIQUETTE BRAND HOLDER SUPPORTO LOGO *2548/028 derecha droite/right/destra *2549/028 izquierda gauche/left/sinistra</p>	INOX S.S. 3 m €/m ∞ 2550/128
<p>TUBO Ø10 TUBE Ø10 TUBE Ø10 TUBO Ø10 *2550/128</p>	INOX S.S. 6 m €/m ∞ 2550/128
<p>CONEXION ENTRE TUBO 2550 Y CARTELA JOINT ENTRE LE TUBE 2550 ET LE SUPPORT JOINT BETWEEN TUBE 2550 AND BRACKET GIUNTO FRA TUBO 2550 E MENSOLA *2551/001</p>	INOX S.S. 3 m 30x15 €/m ∞ 2554/128
<p>TUBO Ø25 TUBE Ø10 TUBE Ø10 TUBO Ø10 *2550/128</p>	INOX S.S. 3 m 30x15 €/m ∞ 2554/128
<p>CONEXION ENTRE TUBO 2552 Y CARTELA JOINT ENTRE LE TUBE 2552 ET LE SUPPORT JOINT BETWEEN TUBE 2552 AND BRACKET GIUNTO FRA TUBO 2552 E MENSOLA *2553/001</p>	
<p>TUBO 30X15 TUBE 30X15 TUBE 30X15 TUBO 30X25 *2554/128</p>	

BASIC MINI

INOX SAT
INOX SAT
S.S.S.
INOX SAT
28

INOX SAT
INOX SAT
S.S.S.
INOX SAT
28

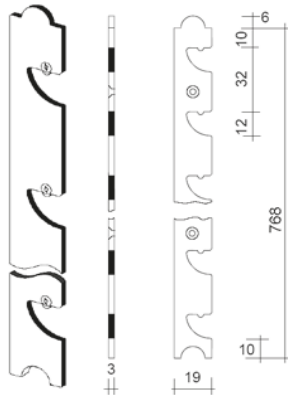

GUÍA CREMALLERA 1 CANAL
CRÉMALLÈRE
RACK
CREMAGLIERA
*2560/028 derecha
droite/right/destra
*2561/028 izquierda
gauche/left/sinistra

inox s.s. ↑ 768 mm 19x3 €/u

*o
*o

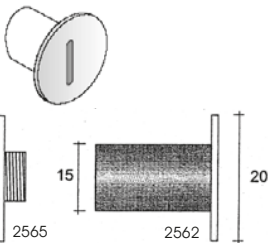

CASQUILLO REDONDO Ø20
Accesorios MINI
INSERT ROND Ø20
Accessoires MINI
ROUND SOCKET Ø20
Fittings MINI
BOCCOLA ROTONDA Ø20
Accessori MINI
*2562/028

Zn Ø 15 mm Ø 20 €/u

*o

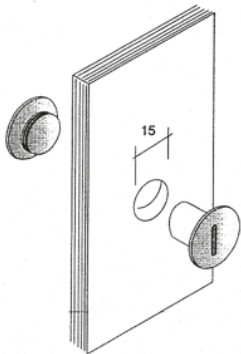

FIJACIÓN POSTERIOR CASQUILLO 2562
FIXATION DERRIÈRE INSERT 2562
BEHIND FIXING SOCKET 2562
FISSAGGIO POSTERIORE BOCCOLA 2562
*2565/028

inox s.s. Ø 20 €/u

*o

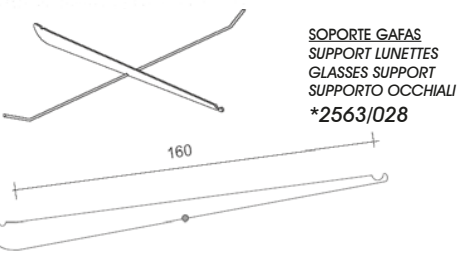

SOPORTE GAFAS
SUPPORT LUNETTES
GLASSES SUPPORT
SUPPORTO OCCHIALI
*2563/028

inox s.s. 160x180 mm €/u

*o

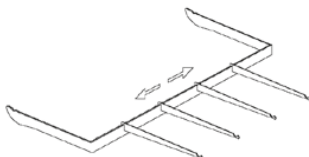

SOPORTE 4 GAFAS
SUPPORT 4 LUNETTES
4 GLASSES SUPPORT
SUPPORTO 4 OCCHIALI
*2564/028

inox s.s. 778 mm €/u

*o

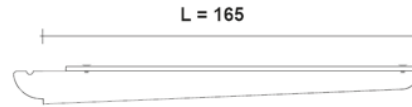

CARTELA ESTANTE VIDRO
SUPPORT TABLETTES VERRE
GLASS SHELF BRACKET
MENSOLA RIPIANO VETRO
*2566/028 derecha
droite/right/destra
*2567/028 izquierda
gauche/left/sinistra

inox s.s. 165 mm €/u
∅ 2571-2570+2556

*o
*o



PEGAR CON "UV"

VIDRIO NO INCLUIDO
VERRE NON INCLUS
GLASS NOT INCLUDED
VETRO NON INLUSO

CARTELA ESTANTE VIDRO
SUPPORT TABLETTES VERRE
GLASS SHELF BRACKET
MENSOLA RIPIANO VETRO
*2568/028

inox s.s. €/u
*o



PORTARÓTULO
SUPPORTÉTIQUETTE
BRAND HOLDER
SUPPORTO LOGO

*2572/028 derecha
droite/right/destra
*2573/028 izquierda
gauche/left/sinistra

inox s.s. 60 mm €/u

*o
*o

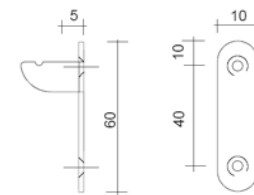

TUBO Ø8
TUBE Ø8
TUBE Ø8
TUBOØ8

*2570/128

inox s.s. L 3 m Ø8 €/m

*o



CONEXIÓN ENTRE TUBO 2570 Y CARTELA
JOINT ENTRE LE TUBE 2570 ET LE SUPPORT
JOINT BETWEEN TUBE 2570 AND BRACKET
GIUNTO FRA TUBO 2570 E MENSOLA
*2571/001

*o



VENTOSA
VENTOUSE
SUCTION
VENTOSA

2556/009

plas Ø14 €/u

o

CONCEPT

LOW COST





PL. MATE
ALU. MAT
ALU. MATT
ALL. NAT
01

Al	‡ 210/350cm	Ø40	€/u
----	-------------	-----	-----

MONTANTE TELESCOPICO COMPLETO
MÂT TÉLESCOPIQUE COMPLET
COMPLET TELESCOPIC ROD
PIANTANA TELESCOPICA COMPLETA
***2700/301**

*o



BASE DE ALUMINIO
BASE EN ALUMINIUM
ALUMINIUM BASE
BASE DI ALLUMINIO
***2702/001**

Al	Ø40	€/u
----	-----	-----

*o



EMPALMADOR TUBO Ø40
JOINT COLONNES TUBE Ø40
COLUMNS JOINT TUBE Ø40
GIUNZIONE PIANTANE TUBO Ø40
***2707/001**

plas	Ø40	€/u
------	-----	-----

*o



NUDO DE ALUMINIO
JOINT EN ALUMINIUM
ALUMINIUM JOINT
GIUNTO DI ALLUMINIO
***2711/001**

PL. MATE
ALU. MAT
ALU. MATT
ALL. NAT
01

Al	Ø40	€/u
----	-----	-----

*o



CARTELA CENTRAL
SUPPORT CENTRAL
CENTRAL BRACKET
MENSOLA ICENTRALE
***2758/00M** derecha
droite/right/destra
***2759/00M** izquierda
gauche/left/sinistra

Fe	275 mm	€/u
	RAL9006	€/u

*o

*o



VENTOSA
VENTOUSE
SUCTION
VENTOSA
319/009

plas	Ø20	€/u
------	-----	-----

o



VENTOSA
VENTOUSE
SUCTION
VENTOSA
2556/009

plas	Ø14	€/u
------	-----	-----

o



ESTANTE REDONDO+ANCLAJES
TABLETTE CIRCULAIRE+ FIXATIONES
ROUND SHELF +JOINTS
RIPIANO CIRCOLARE+FISSAGGI
***2718/001**

Al	4 mm	€/u
	Ø500	€/u

*o

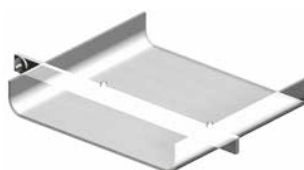

CARTELA LATERAL + ESTANTE
SUPPORT LATERAL + TABLETTE
BRACKET + SHELF
MENSOLA + RIPIANO
***2719/001**

Al	420x390	€/u
	5 mm	€/u

*o

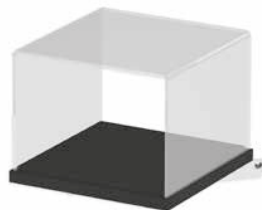

VITRINA CON CERRADURA
VETRINE AVEC SERRURE
SHOWCASE WITH LOCK
VETRINA CON SERRATURA
***2760/001**

MD plas	€/u
30,5x30,5x20 cm	

*o

NEGRO
NOIR
BLACK
NERO



SOPORTE LATERAL PARA MUEBLES
SUPPORT LATERAL POUR MOBLES
LATERAL SUPPORT FOR FURNITURE
SUPPORTO LATERALE PER MOBILI
***2736/001**

Al	30 mm M8	€/u
	Ø10	€/u

*o

CONCEPT

LOW COST

PL. MATE
ALU. MAT
ALU. MATT
ALL. NAT
01

PL. MATE
ALU. MAT
ALU. MATT
ALL. NAT
01

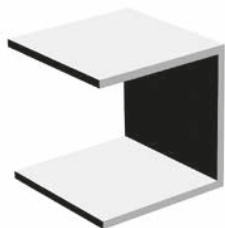

MÓDULO LATERAL MADERA
Module lateral bois
Wood lateral module
modulo laterale legno
***2737/00B**

BLANCO
BLANC
WHITE
BIANCO

MD 39,5x39,5x39 cm
∞ 2736 (x2) €/u

*o

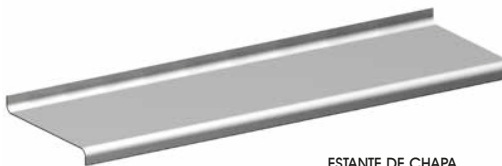

ESTANTE DE CHAPA
TABLETTE TÔLE
METAL SHEET SHELF
RIPIANO METALLICO
***2726/00M 119x42 cm**
***2729/00M 93x42 cm**

Fe 2 mm
RAL9006 €/u

*o
*o



MÓDULO CENTRALE MADERA
Module central bois
Wood central module
modulo centrale legno
***2739/00B**

BLANCO
BLANC
WHITE
BIANCO

MD 88,4x39,5x39 cm
∞ 2736 (x4) €/u

*o



SOPORTE PARA BUSTOS
SUPPORT POUR BUSTE
BUST SUPPORT
SUPPORTO BUSTO
***2713/001**

Al 125 mm M8 €/u

*o



SOPORTE INCLINABLE ESTANTE
SUPPORT INCLINABLE TABLETTE
TILT BRACKET SHELF
SUPPORTO INCLINABILE RIPIANO
***2720/001**

Al 6 mm €/u

*o



SOPORTE INCLINABLE ESTANTE
SUPPORT INCLINABLE TABLETTE
TILT BRACKET SHELF
SUPPORTO INCLINABILE RIPIANO
***2721/001**

Al 6 mm €/u

*o



SOPORTE INCLINABLE FIJO
SUPPORT INCLINABLE FIXE
FIX TILT BRACKET
SUPPORTO INCLINABILE FISSO
***2722/001**

Al 6 mm
0°-45°-90° €/u

*o



SOPORTE INCLINABLE REGULABLE
SUPPORT INCLINABLE RÉGLABLE
ADJUSTABLE TILT BRACKET
SUPPORTO INCLINABILE REGOLABILE
***2723/001**

Al 6 mm €/u
0°-45°-90°

*o



BUSTO MUJER
BUSTE FÉMME
WOMAN BUST
BUSTO DONNA
***2750/00B**

plac €/u

*o

BLANCO
BLANC
WHITE
BIANCO

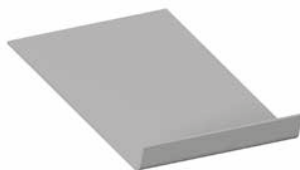

ESTANTE METACRILATO
TABLETTE MÉTHACRYLATE
SHELF METHACRYLATE
RIPIANO PLEXIGLASS
***2724/009**

BLANCO
BLANC
WHITE
BIANCO

Al 300x400 mm
4 mm €/u

*o



ESTANTE METACRILATO
TABLETTE MÉTHACRYLATE
SHELF METHACRYLATE
RIPIANO PLEXIGLASS
***2725/009**

BLANCO
BLANC
WHITE
BIANCO

Al 4 mm
∅350 €/u

*o



PRECIOS

LOS PRECIOS DE ESTA TARIFA SON P.V.P.
(PRECIOS DE VENTA AL PÚBLICO
RECOMENDADOS)

Los precios netos de facturación se
corresponderán a los precios PVP de la
Tarifa menos el descuento asignado

PVP menos:

DESCUENTO

CONDICIONES PAGO

Los pagos están asegurados por Crédito y
Caución. En caso que los clientes no tengan
concedido el crédito por parte de CyC,
el pago tendrá que hacerse por anticipado
antes de la salida de la mercancía.

- Giro bancario - Pagaré - Transferencia

Días a fecha factura

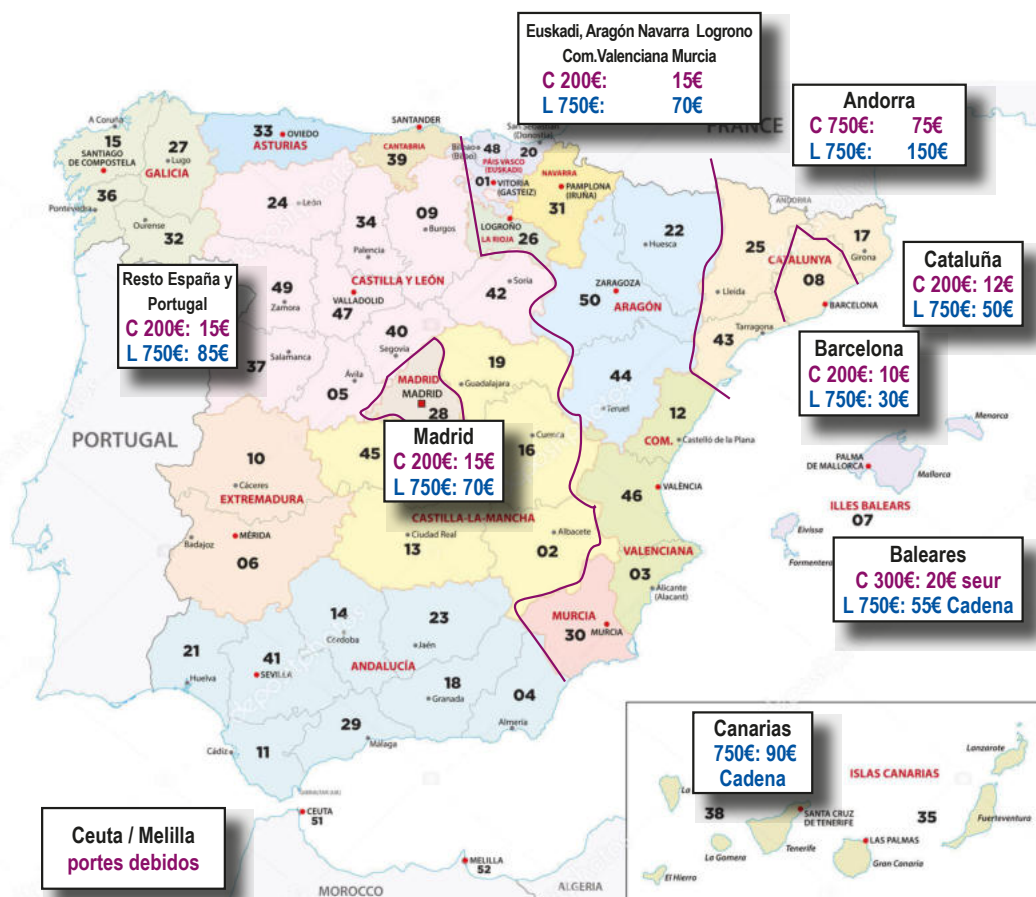

CONDICIONES PORTES ESPAÑA, ANDORRA y PORTUGAL

Los portes pagados son ofrecidos por Alu System como un servicio incluido en el precio para aquellos pedidos de un importe mínimo en función del largo y peso de la mercancía con la finalidad de facilitar los trámites a los clientes. Alu System no se hace responsable de eventuales retrasos e incidencias imputables a las agencias de transporte subcontratadas. Lamentablemente en algunas zonas de España, la entrega de los pedido mediante ONTIME (único operador en el mercado de "Largos" en España) puede comportar esperas de más de una semana: si el cliente dispone de medios propios, recomendamos utilizarlos o de enviar los pedidos con amplia antelación respecto a las previsiones de montaje.

CORTOS (C): se consideran "cortos" los bultos con material de 2,5 m de largo (sin embalaje) y los bultos de peso inferior a 40 kg. Se enviarán por paquetería (SEUR).

Excepciones:

- en el caso de petición expresa del cliente, los bulto de 2,5 m hasta 3 m de largo se enviaran con un suplemento en factura de 20 €/bulto mediante SEUR.
- los pedidos facturados a Andorra y recogidos en España tendrán un suplemento de 20€ por gastos de aduana.

Largos (L): Se consideran "largos" los bultos de dimensiones superior a 2,5 m (medida de corte) y los envíos de peso superior a 40 kg se enviarán por ONTIME. Todos los pedidos de 3 m hasta 6 m de largo solo se pueden enviar por ONTIME.

Excepciones: si el cliente comunica expresamente que el envío de bultos de peso superior a 40 Kg se haga mediante SEUR, se cargará un suplemento correspondiente de:

- 20 €/envío de 40 a 100 kg
- 30 €/envío de 100 kg a 200 kg (consultar pesos superiores a 200 kg)

PEDIDO MÍNIMO

No hay pedio mínimo, pero se añadirá al coste de los portes en factura un suplemento de 7 € a partir de :

- Cataluña: pedidos inferiores a 50€
- Resto península y Baleares: pedidos inferiores a 75€

Galería de imágenes | COTEK

cotek.

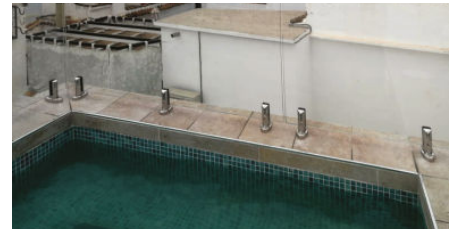

metal.

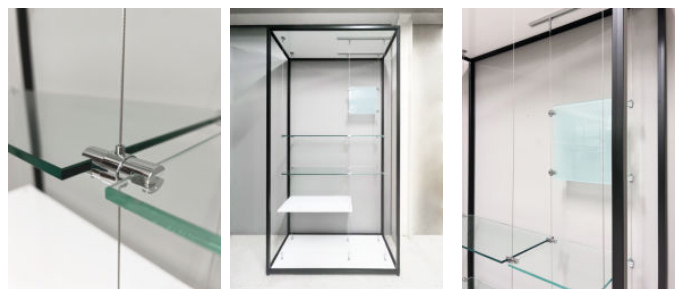

instal.



CONDICIONES DE VENTAS

1. El comprador, al efectuar el pedido, acepta las condiciones de venta estipuladas por ALU-SYSTEM, S.A.U.

2. ALU-SYSTEM, S.A.U. se reserva el derecho de aceptar los pedidos del comprador, en función de la situación jurídica, solvencia y otras consideraciones comerciales que reuna éste.

3. Todas las ventas se entienden realizadas en el domicilio social de ALU-SYSTEM, S.A.U., y en el mismo, el comprador se hace cargo de los géneros adquiridos. Las mercancías viajan por cuenta y riesgo del comprador.

Por pacto entre ambas partes, ALU-SYSTEM, S.A.U. entregará los pedidos en el domicilio del comprador, mediante el transportista que ALU-SYSTEM, S.A.U. designe, en régimen de portes pagados. En función del importe mínimo que ALU-SYSTEM, S.A.U. establezca, se cargará el importe del transporte en la correspondiente factura.

Si por motivos de urgencia del comprador, los pedidos se tuvieran que enviar por transporte urgente o por otro medio de transporte distinto del designado por ALU-SYSTEM, S.A., la mercancía se remitirá en régimen de portes debidos (salvo correos y postal-express, en cuyo caso se enviará a portes pagados y posteriormente se cargará en factura), independientemente del importe del pedido.

4. Los precios establecidos en el presente catálogo no incluyen tasas o impuestos vigentes.

ALU-SYSTEM, S.A.U. podrá establecer descuentos promocionales o condiciones especiales por la cuantía de los pedidos, así como cualquier tipo de oferta por razones de estrategia comercial.

Estos descuentos, condiciones especiales y ofertas, no serán acumulables y tendrán el vigor temporal que ALU-SYSTEM, S.A.U. considere.

El % de descuento por pronto pago, quedará condicionado a que el cobro correspondiente se efectue dentro de los 15 días posteriores a la emisión de la factura.

5. ALU-SYSTEM, S.A.U. no admitirá devoluciones de material que no estén previamente justificadas y comunicadas.

Los portes de las devoluciones correrán por cuenta del comprador.

ALU-SYSTEM, S.A.U. se reserva el derecho a efectuar abono sobre las devoluciones, quedando condicionado al examen del estado de la mercancía.

Salvo pacto en contra, el importe de los abonos se deducirá en próximas facturas.

6. Se establece un plazo de pago de 30 días, a contar desde la fecha de emisión de la factura, salvo pacto distinto entre ALU-SYSTEM, S.A.U. y el comprador con respecto a lo que la legislación vigente estipule.

La demora en el pago dará potestad a ALU-SYSTEM, S.A.U. a cargar los correspondientes intereses, paralizar pedidos en curso y/o reclamar la totalidad de importes adeudados por el comprador, aunque no estén vencidos.

El pago deberá hacerse en el domicilio social de ALU-SYSTEM, S.A.U. El hecho voluntario por parte de ALU-SYSTEM, S.A.U. de librar giros para mayor comodidad del comprador, no puede interpretarse como una renuncia al lugar de pago establecido.

7. Cualquier reclamación sobre la mercancía remitida por ALU-SYSTEM, S.A.U., deberá hacerla el comprador dentro del plazo de 8 días, a contar desde la recepción de la mercancía.

8. Hasta el pago total de las mercancías, ALU-SYSTEM, S.A.U. se reserva el dominio de éstas, sin asumir por su parte otros riesgos, (pérdida, deterioro, etc.).

En caso de que ALU-SYSTEM, S.A.U. tuviera que hacer uso de dicha reserva, los costes de reposición de materiales correrán a cargo del comprador.

9. El comprador se somete expresamente al fuero y competencia de los Juzgados y Tribunales de Barcelona, para dirimir cualquier cuestión o divergencia, renunciando a fueros propios.

10. ALU-SYSTEM, S.A.U. se reserva el derecho de modificar el contenido de estas condiciones generales de venta.

11. ALU-SYSTEM S.A.U. se reserva la libertad de modificar los precios de venta en caso de fuertes subidas de la materia prima.

12. ALU-SYSTEM S.A.U. no se hace responsable de los artículos instalados inadecuadamente ni de trabajos de sustitución.

13. El plazo de entrega de producto de procedencia internacional es orientativo, en caso de retraso se informará.

14. ALU-SYSTEM S.A.U. no acepta pedidos con cláusulas de penalización que no sean firmadas expresamente en un contrato específico.